



Chipsmall Limited consists of a professional team with an average of over 10 year of expertise in the distribution of electronic components. Based in Hongkong, we have already established firm and mutual-benefit business relationships with customers from,Europe,America and south Asia,supplying obsolete and hard-to-find components to meet their specific needs.

With the principle of “Quality Parts,Customers Priority,Honest Operation,and Considerate Service”,our business mainly focus on the distribution of electronic components. Line cards we deal with include Microchip,ALPS,ROHM,Xilinx,Pulse,ON,Everlight and Freescale. Main products comprise IC,Modules,Potentiometer,IC Socket,Relay,Connector.Our parts cover such applications as commercial,industrial, and automotives areas.

We are looking forward to setting up business relationship with you and hope to provide you with the best service and solution. Let us make a better world for our industry!



Contact us

Tel: +86-755-8981 8866 Fax: +86-755-8427 6832

Email & Skype: info@chipsmall.com Web: www.chipsmall.com

Address: A1208, Overseas Decoration Building, #122 Zhenhua RD., Futian, Shenzhen, China





MAGNETIC JACK CONNECTORS (A60 SERIES)

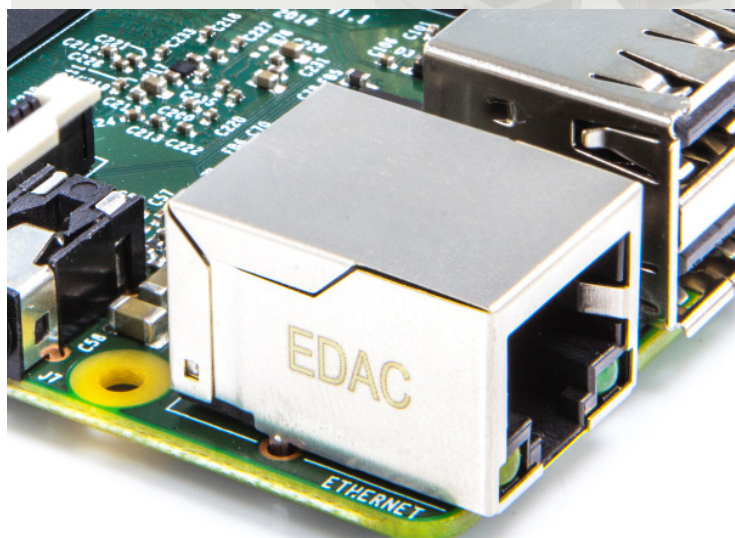
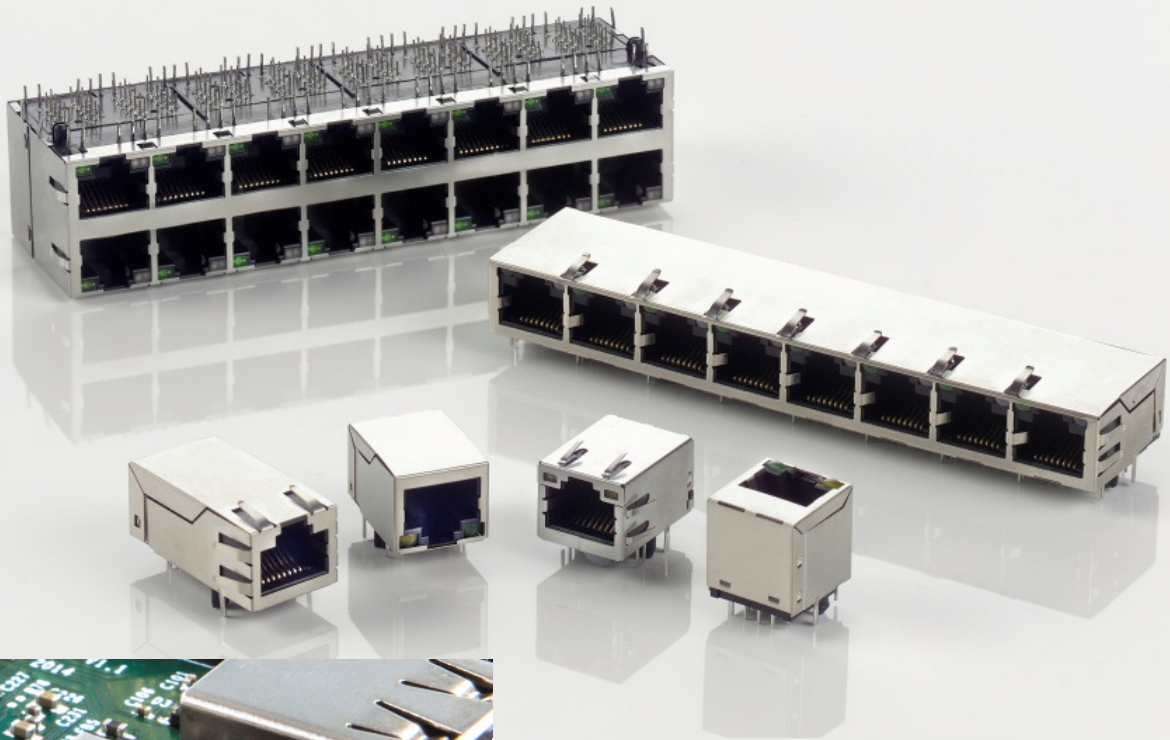

1. MECHANICAL DIMENSIONS:

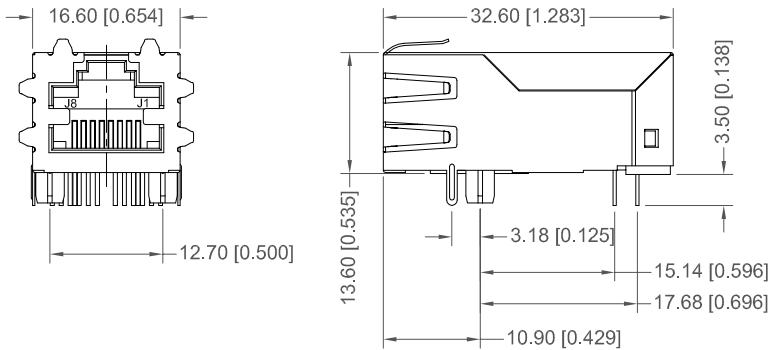

PART NO	GOLD PLATING THICKNESS
A60-112-200P471	GOLD FLASH PLATING
A60-113-200P471	15 MICRO INCHES OF GOLD
A60-114-200P471	30 MICRO INCHES OF GOLD

**10/100/1000 Mbps, Without LED, Latch-Up
12P, 8C Shielded**

2. SCHEMATIC:

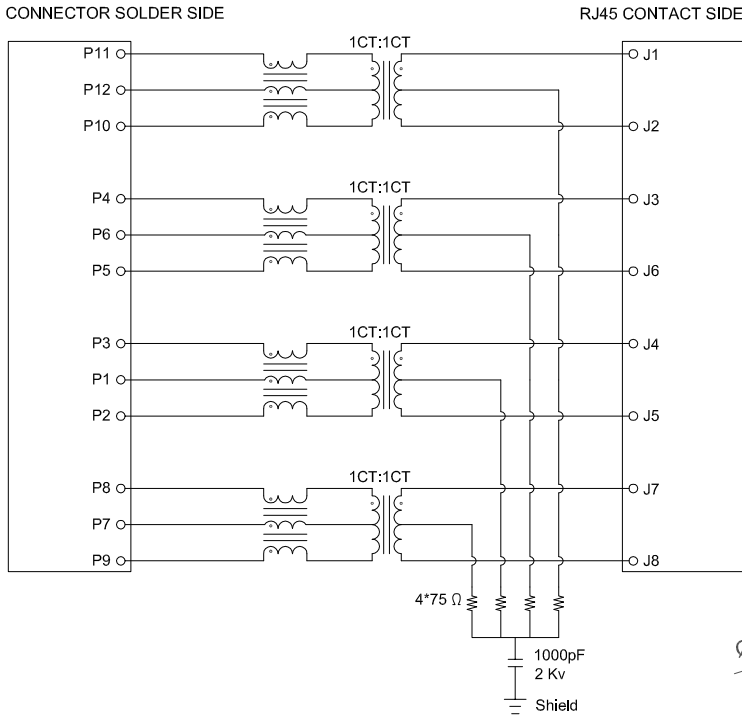

4. PCB LAYOUT (Top View)

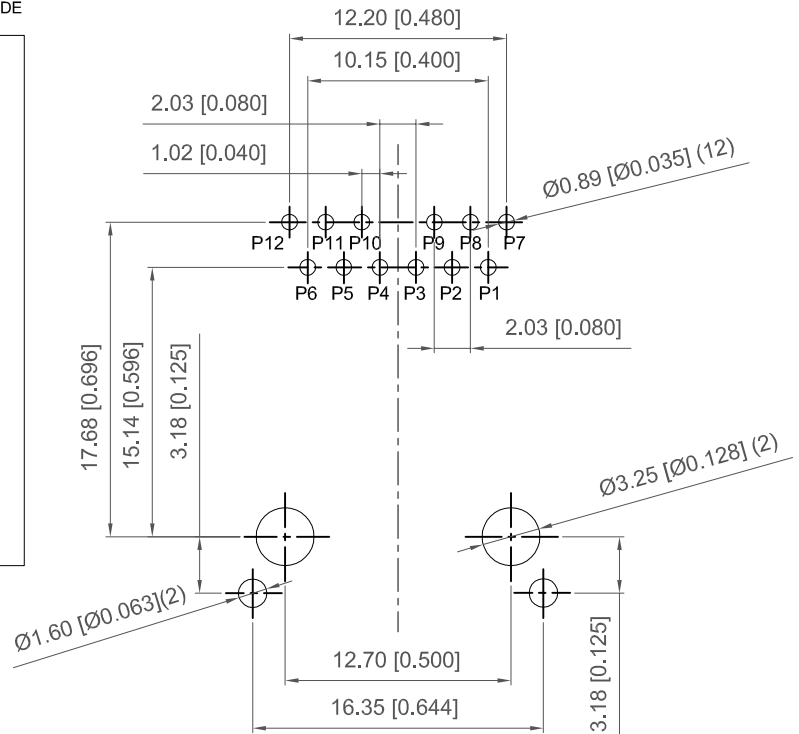

3. ELECTRICAL CHARACTERISTICS:

Cross Talk	Insertion Loss	Return Loss		CMRR	Isolation PHY
1MHz-100MHz	1MHz-100MHz	1MHz-40MHz	60MHz-80MHz	1MHz-100MHz	2250 VDC
-30dB (Min)	-1dB (Max)	-16dB (Min)	-10dB (Min)	-30dB (Min)	PHY Side to Line Side

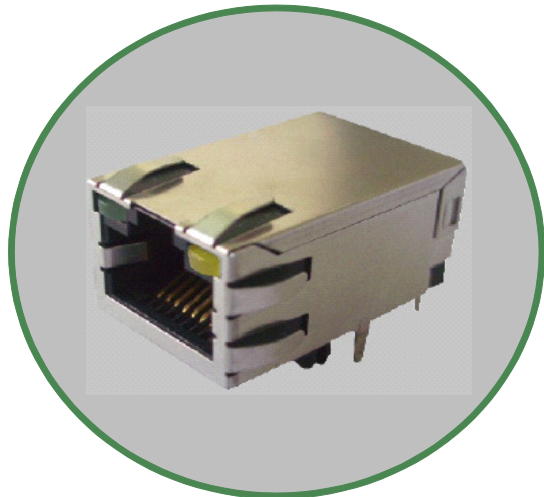

1. MECHANICAL DIMENSIONS:

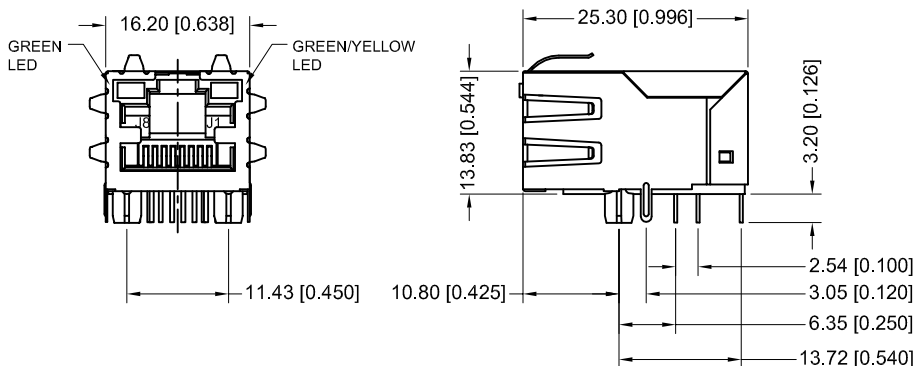

10/100/1000 Mbps, With LED, Latch-Up
10P, 8C, Shielded

PART NO	GOLD PLATING THICKNESS
A60-112-235N414	GOLD FLASH PLATING
A60-113-235N414	15 MICRO INCHES OF GOLD
A60-114-235N414	30 MICRO INCHES OF GOLD

2. SCHEMATIC:

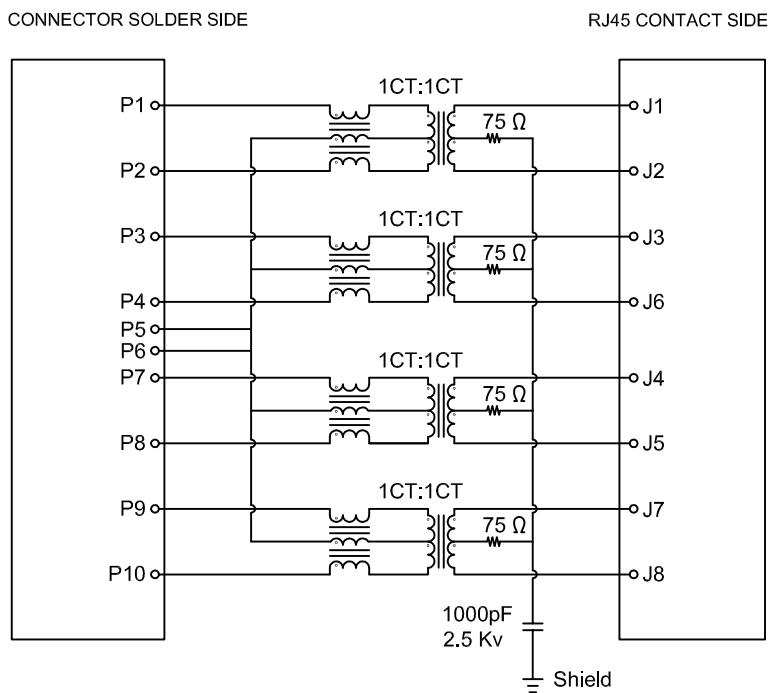

4. PCB LAYOUT (Top View)

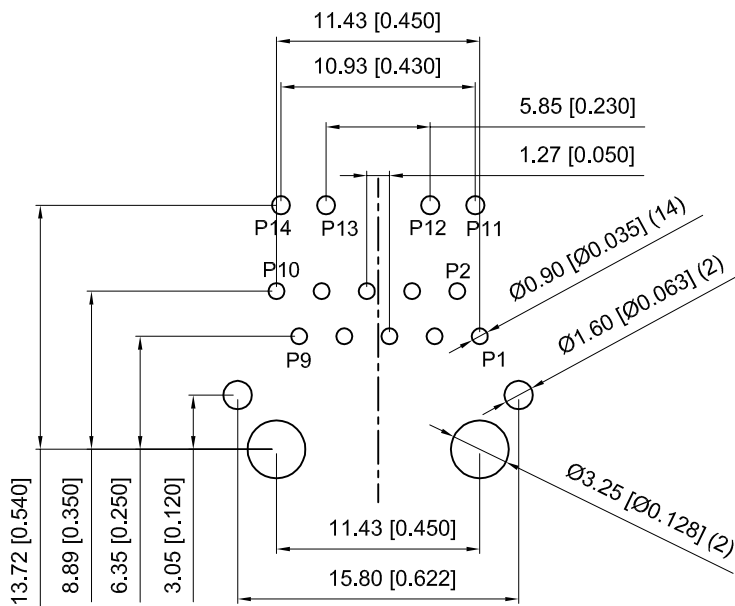

3. ELECTRICAL CHARACTERISTICS:

Cross Talk	Insertion Loss	Return Loss		CMRR	Isolation PHY
1MHz-100MHz	1MHz-100MHz	1MHz-40MHz	60MHz-80MHz	1MHz-100MHz	2250 VDC
-30dB (Min)	-1dB (Max)	-16dB (Min)	-10dB (Min)	-30dB (Min)	PHY Side to Line Side

1. MECHANICAL DIMENSIONS:

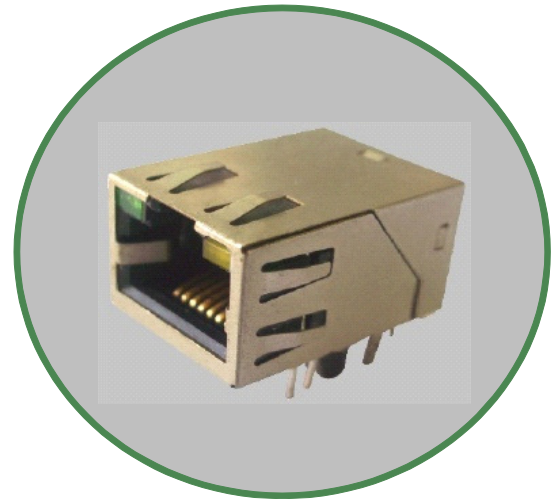
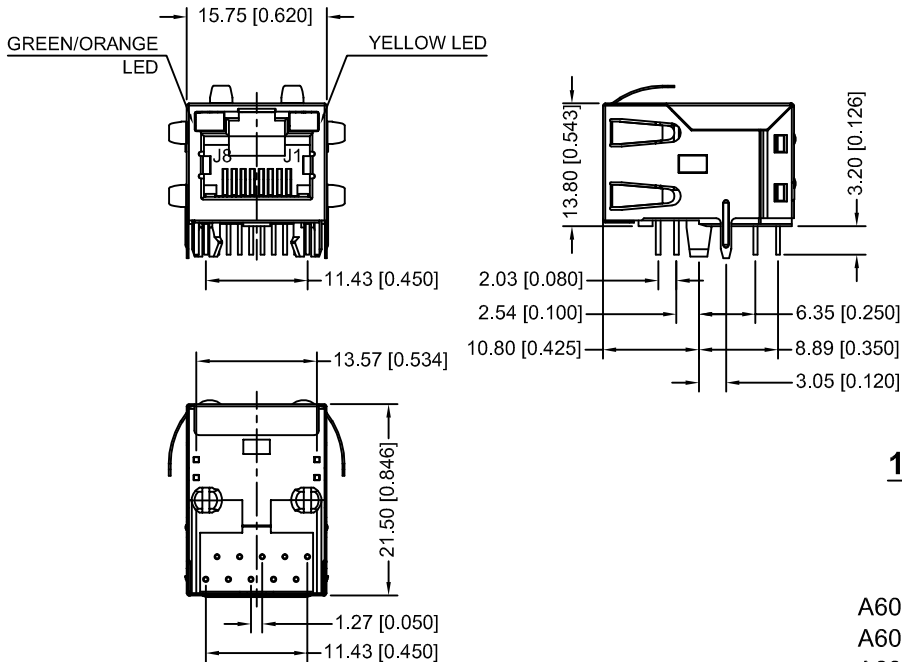

10/100/1000 Mbps, With LED, Latch-Up 10P, 8C, Shielded

PART NO	GOLD PLATING THICKNESS
A60-112-271N414	GOLD FLASH PLATING
A60-113-271N414	15 MICRO INCHES OF GOLD
A60-114-271N414	30 MICRO INCHES OF GOLD

2. SCHEMATIC:

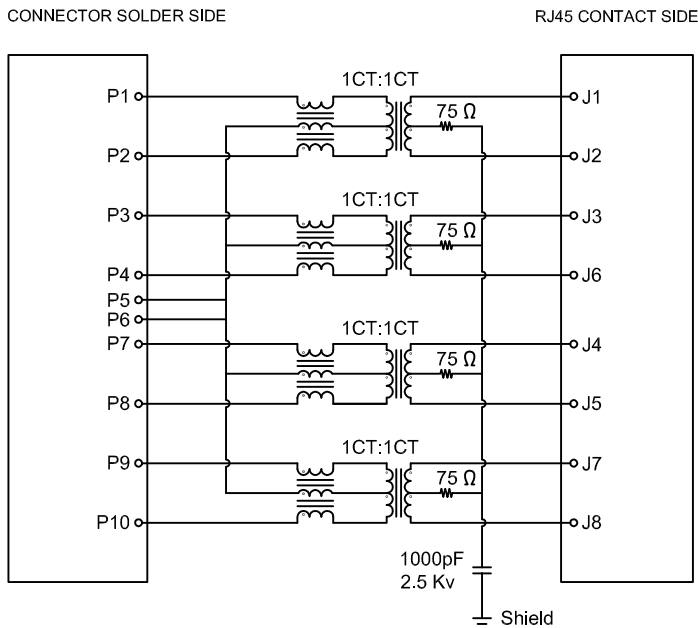

4. PCB LAYOUT (Top View)

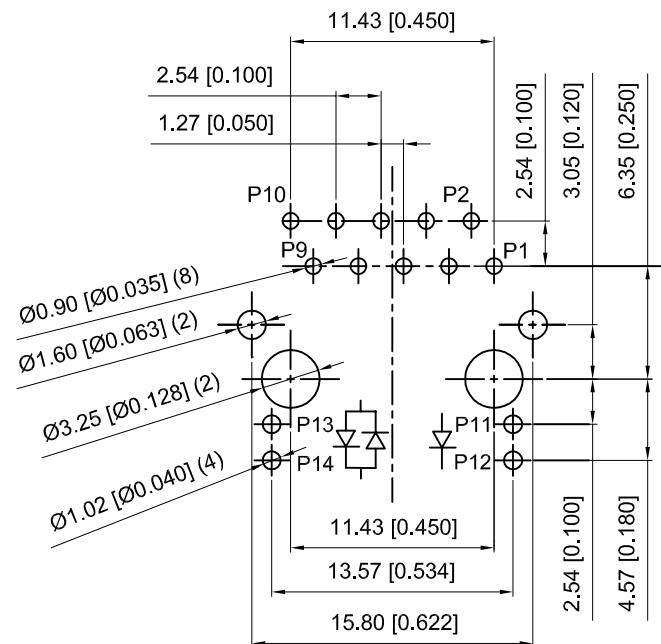

3. ELECTRICAL CHARACTERISTICS:

Cross Talk	Insertion Loss	Return Loss		CMRR	Isolation PHY
1MHz-100MHz	1MHz-100MHz	1MHz-40MHz	60MHz-80MHz	1MHz-100MHz	2250 VDC
-30dB (Min)	-1dB (Max)	-16dB (Min)	-10dB (Min)	-30dB (Min)	PHY Side to Line Side

1. MECHANICAL DIMENSIONS:

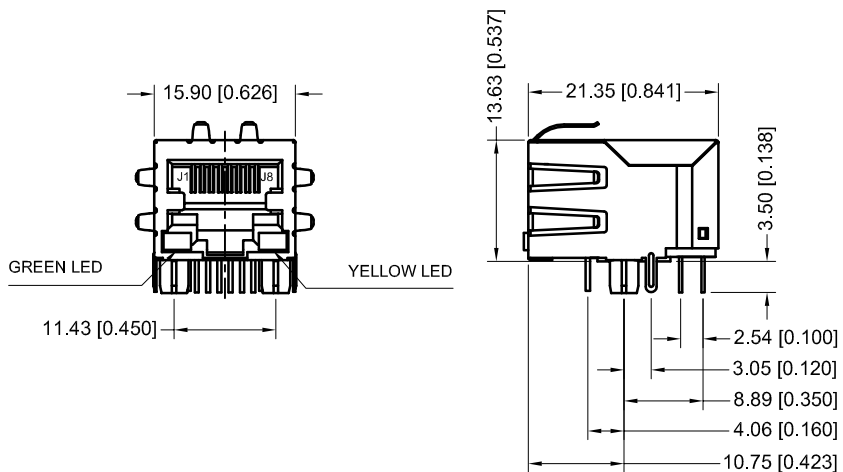
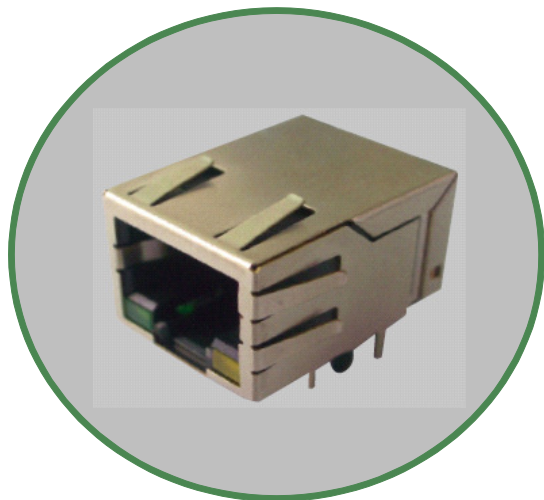

10/100/1000 Mbps, With LED, Latch-Down
10P, 8C, Shielded

PART NO
 A60-112-331P411
 A60-113-331P411
 A60-114-331P411

GOLD PLATING THICKNESS
 GOLD FLASH PLATING
 15 MICRO INCHES OF GOLD
 30 MICRO INCHES OF GOLD

2. SCHEMATIC:

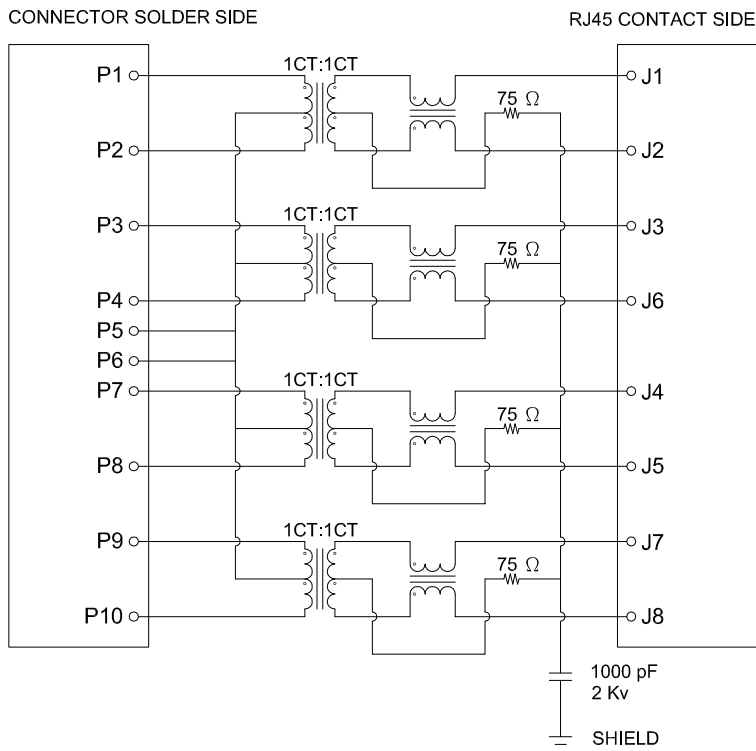

4. PCB LAYOUT (Top View)

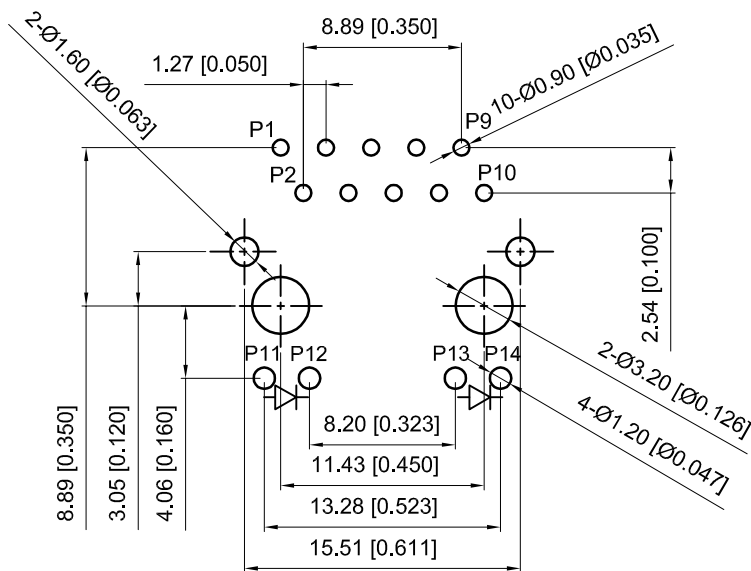

3. ELECTRICAL CHARACTERISTICS:

Cross Talk	Insertion Loss	Return Loss	CMRR	Isolation PHY
1MHz-100MHz	1MHz-100MHz	1MHz-40MHz	60MHz-80MHz	1MHz-100MHz
-30dB (Min)	-1dB (Max)	-16dB (Min)	-10dB (Min)	-30dB (Min)
				2250 VDC
				PHY Side to Line Side

1. MECHANICAL DIMENSIONS:

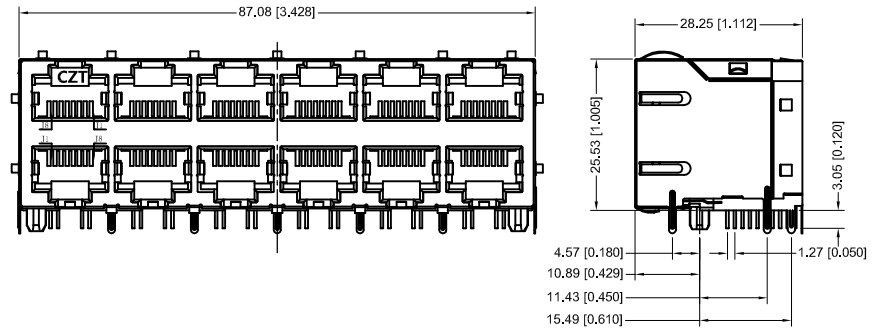

10/100/1000 Mbps, Without LED, 2 X 6 Port
10P, 8C, Shielded

PART NO	GOLD PLATING THICKNESS
A60-262-300P562	GOLD FLASH PLATING
A60-263-300P562	15 MICRO INCHES OF GOLD
A60-264-300P562	30 MICRO INCHES OF GOLD

2. SCHEMATIC:

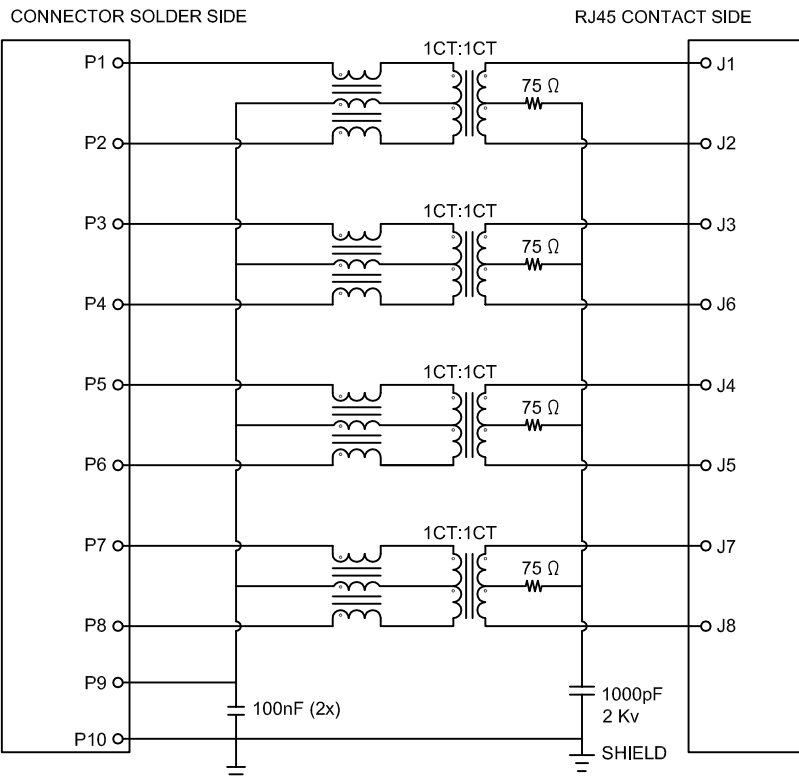

4. PCB LAYOUT (Top View)

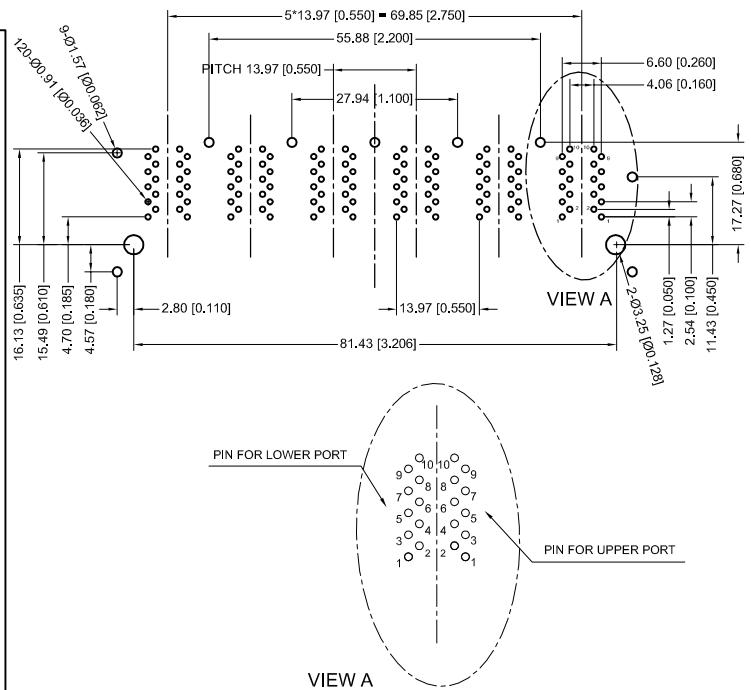

3. ELECTRICAL CHARACTERISTICS:

Cross Talk	Insertion Loss	Return Loss		CMRR	Hi-Pot Test	
1MHz-100MHz	1MHz-100MHz	1MHz-40MHz	60MHz-80MHz	1MHz-100MHz	1200 VAC	
-30dB (Min)	-1dB (Max)	-16dB (Min)	-10dB (Min)	-30dB (Min)	(P1,P2):(J1,J2)	(P5,P6):(J4,J5)
					(P3,P4):(J3,J6)	(P7,P8):(J7,J8)

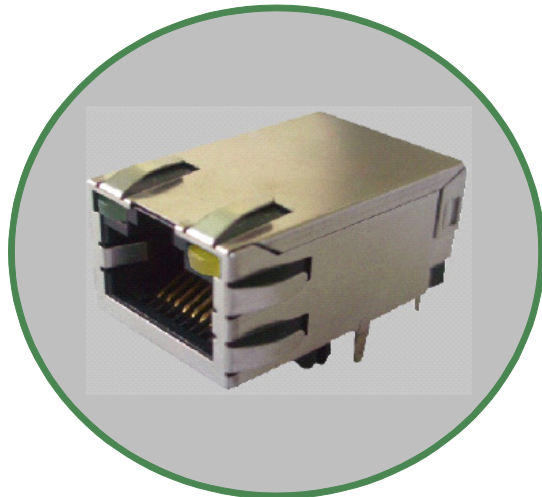

1. MECHANICAL DIMENSIONS:

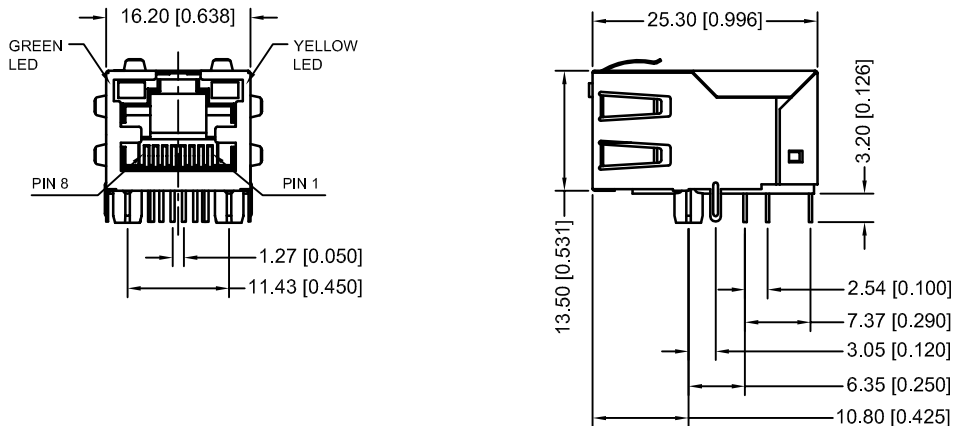

10/100/1000 Mbps, With LED, Latch-Up
10P, 8C, Shielded

PART NO	GOLD PLATING THICKNESS
A60-112-231N432	GOLD FLASH PLATING
A60-113-231N432	15 MICRO INCHES OF GOLD
A60-114-231N432	30 MICRO INCHES OF GOLD

2. SCHEMATIC:

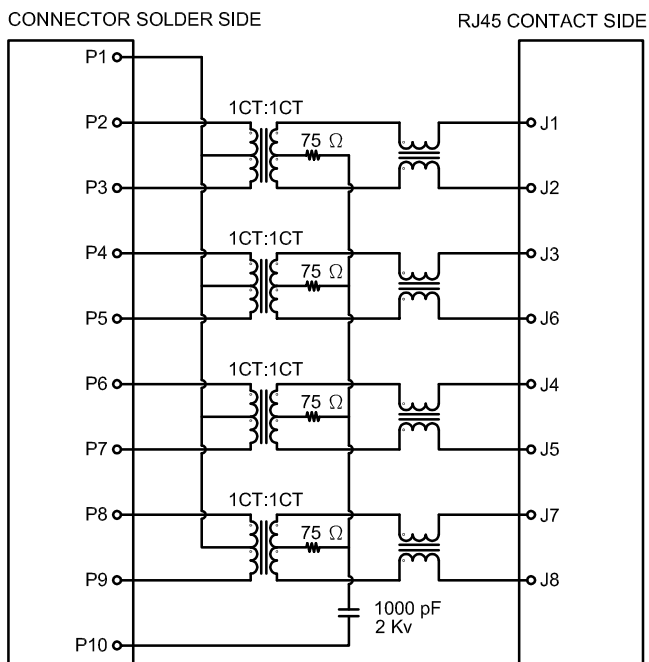

4. PCB LAYOUT (Top View)

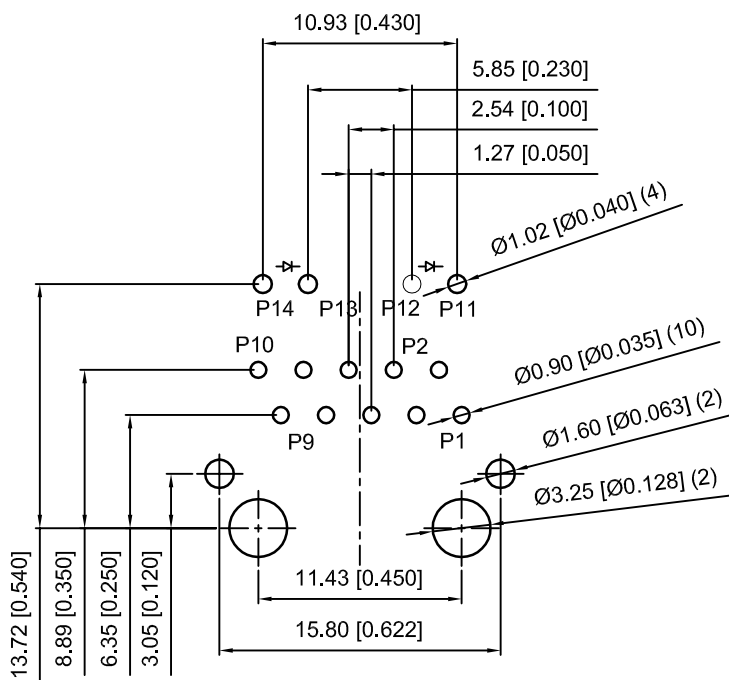

3. ELECTRICAL CHARACTERISTICS:

Cross Talk	Insertion Loss	Return Loss		CMRR	Hi-Pot Test	
1MHz-100MHz	1MHz-100MHz	1MHz-40MHz	60MHz-80MHz	1MHz-100MHz	1500VAC or 2250VDC	
-30dB (Min)	-1dB (Max)	-16dB (Min)	-10dB (Min)	-30dB (Min)	(P2,P3):(J1,J2) (P4,P5):(J3,J6)	(P6,P7):(J4,J5) (P8,P9):(J7,J8)

1. MECHANICAL DIMENSIONS:

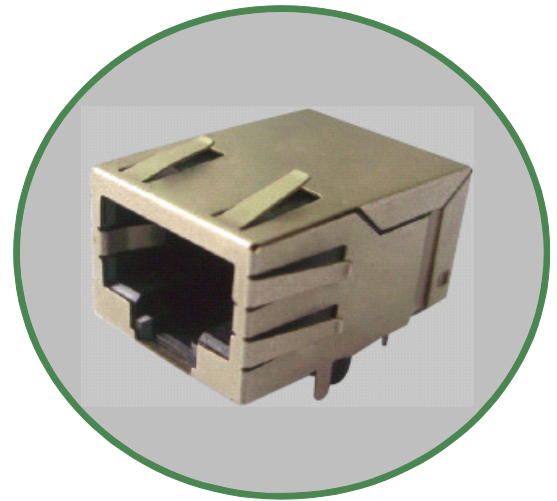
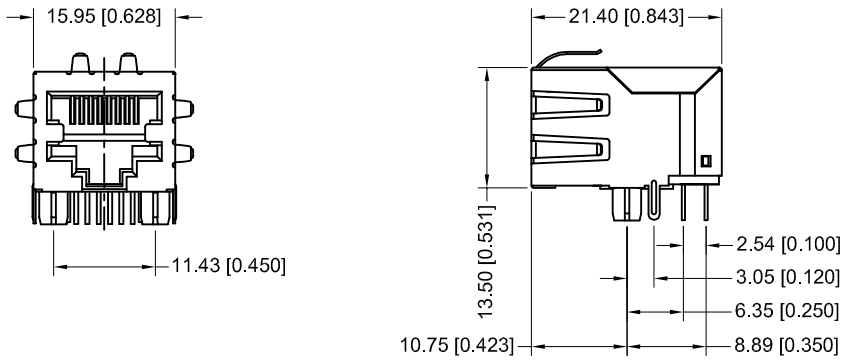

**10/100/1000 Mbps, Without LED, Latch-Down
10P, 8C, Shielded**

PART NO	GOLD PLATING THICKNESS
A60-112-300P492	GOLD FLASH PLATING
A60-113-300P492	15 MICRO INCHES OF GOLD
A60-114-300P492	30 MICRO INCHES OF GOLD

2. SCHEMATIC:

CONNECTOR SOLDER SIDE

RJ45 CONTACT SIDE

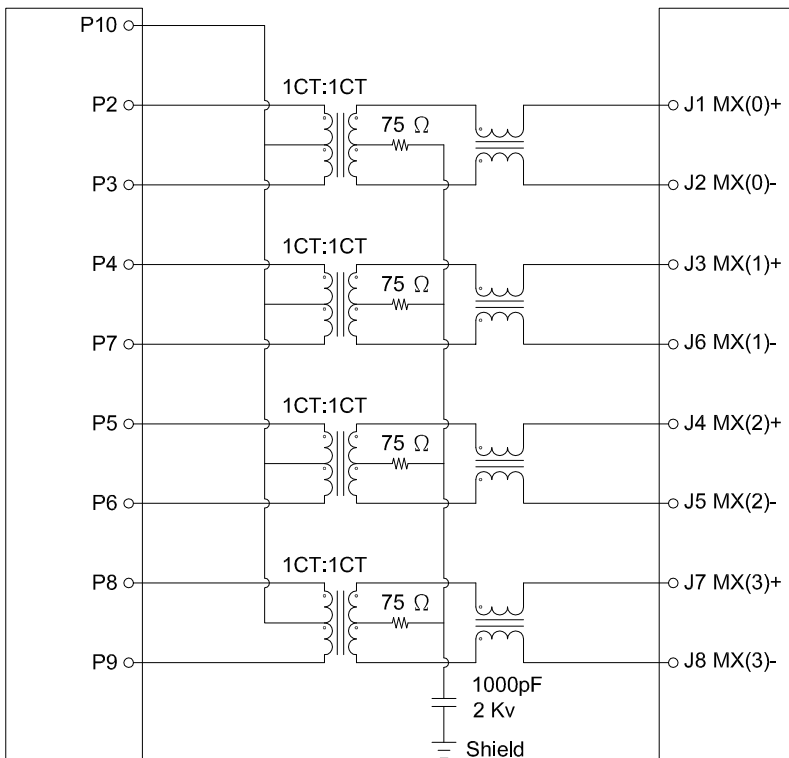

4. PCB LAYOUT (Top View)

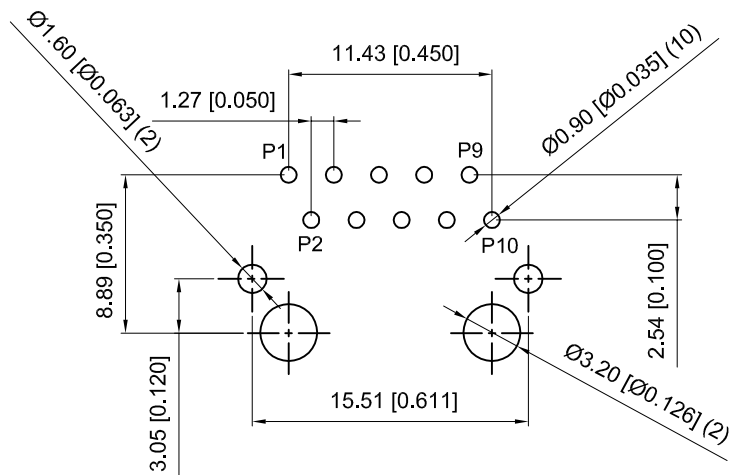

3. ELECTRICAL CHARACTERISTICS:

Cross Talk	Insertion Loss	Return Loss	CMRR	Hi-Pot Test
1MHz-100MHz	1MHz-100MHz	1MHz-40MHz	60MHz-80MHz	1500VAC or 2250VDC
-30dB (Min)	-1dB (Max)	-16dB (Min)	-10dB (Min)	(P2,P3):(J1,J2) (P5,P6):(J4,J5) (P4,P7):(J3,J6) (P8,P9):(J7,J8)

1. MECHANICAL DIMENSIONS:

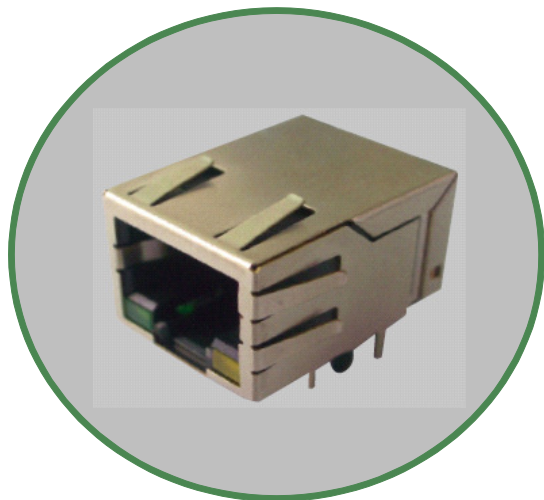

**10/100/1000 Mbps, With LED, Latch-Down
10P, 8C, Shielded**

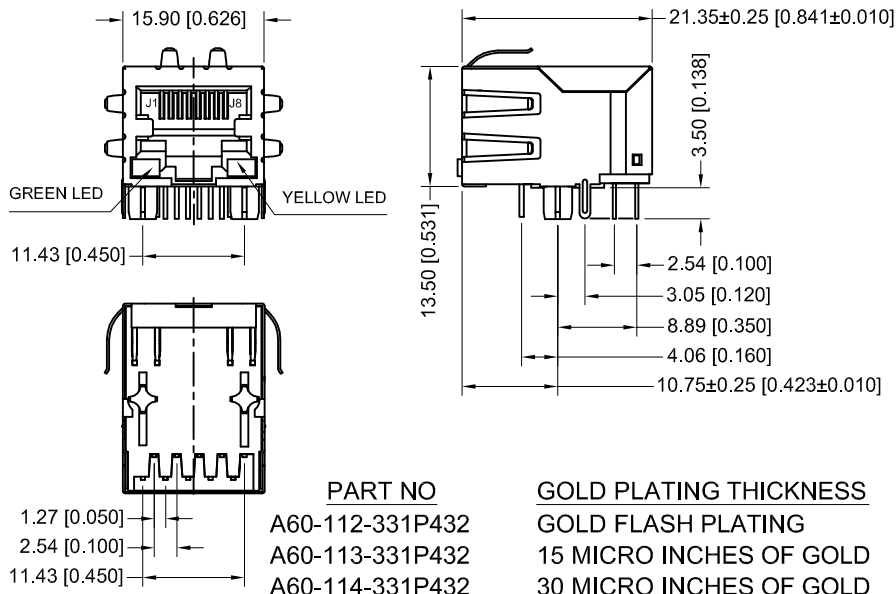

2. SCHEMATIC:

CONNECTOR SOLDER SIDE

RJ45 CONTACT SIDE

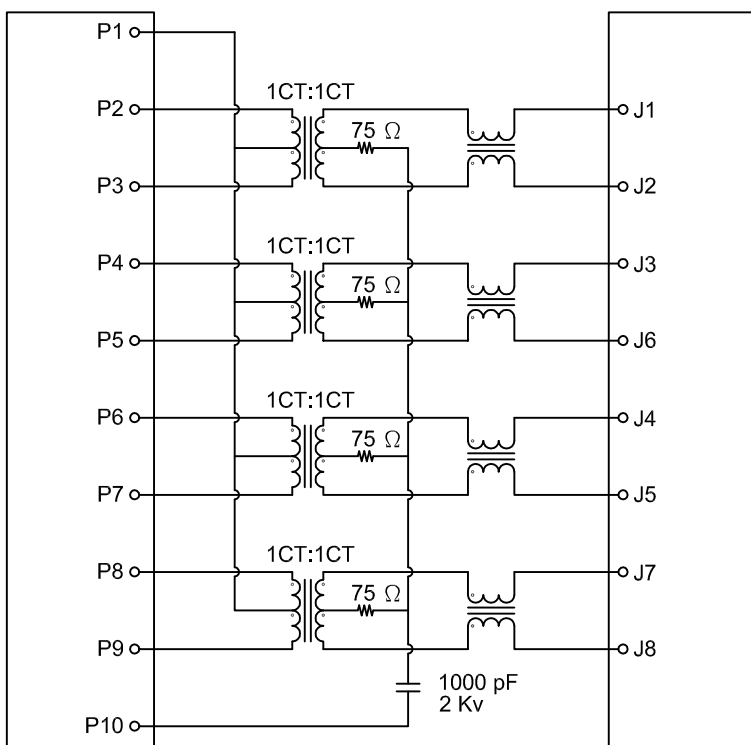

4. PCB LAYOUT (Top View)

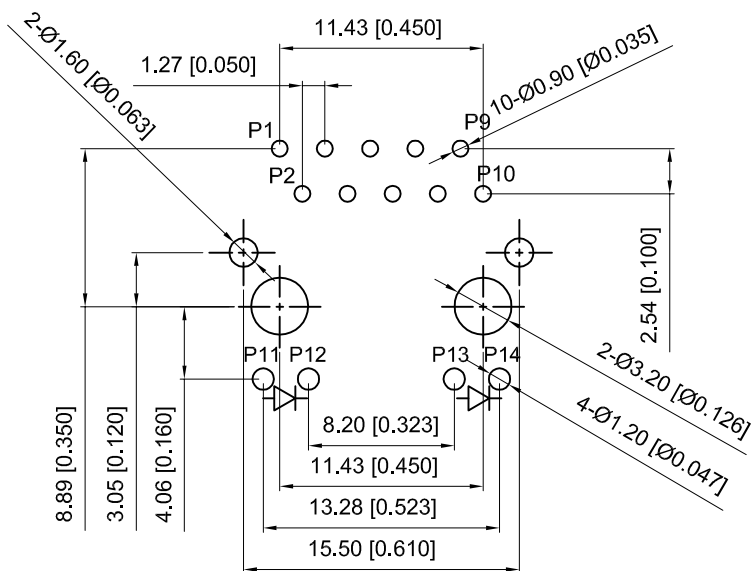

3. ELECTRICAL CHARACTERISTICS:

Cross Talk	Insertion Loss	Return Loss		CMRR	Hi-Pot Test
1MHz-100MHz	1MHz-100MHz	1MHz-40MHz	60MHz-80MHz	1MHz-100MHz	1500VAC or 2250VDC
-30dB (Min)	-1dB (Max)	-16dB (Max)	-10dB (Max)	-30dB (Min)	(P2,P3):(J1,J2) (P6,P7):(J4,J5) (P4,P5):(J3,J6) (P8,P9):(J7,J8)

1. MECHANICAL DIMENSIONS:

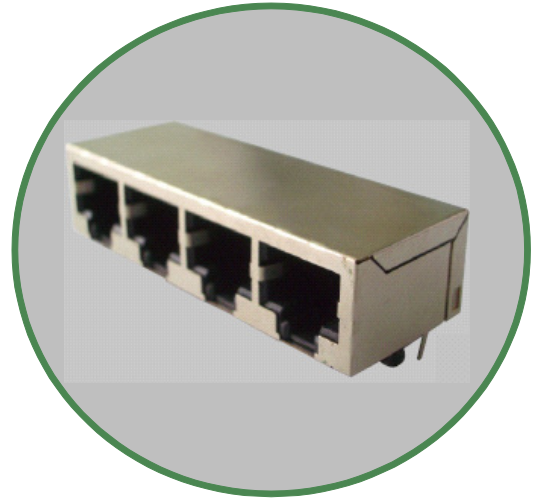
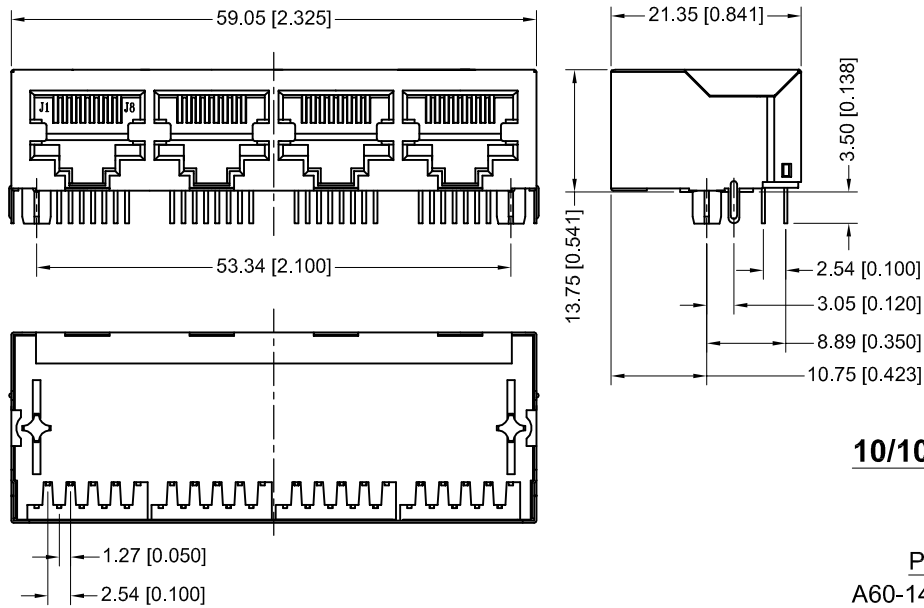

10/100/1000 Mbps, Without LED, 1x4 Port
10P, 8C, Shielded

PART NO	GOLD PLATING THICKNESS
A60-142-300P111	GOLD FLASH PLATING
A60-143-300P111	15 MICRO INCHES OF GOLD
A60-144-300P111	30 MICRO INCHES OF GOLD

2. SCHEMATIC:

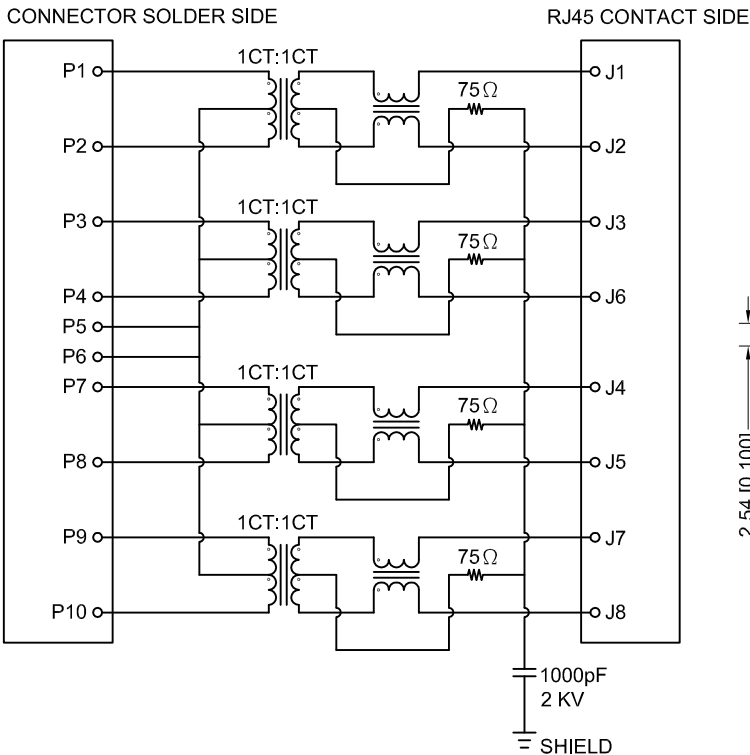

4. PCB LAYOUT (Top View)

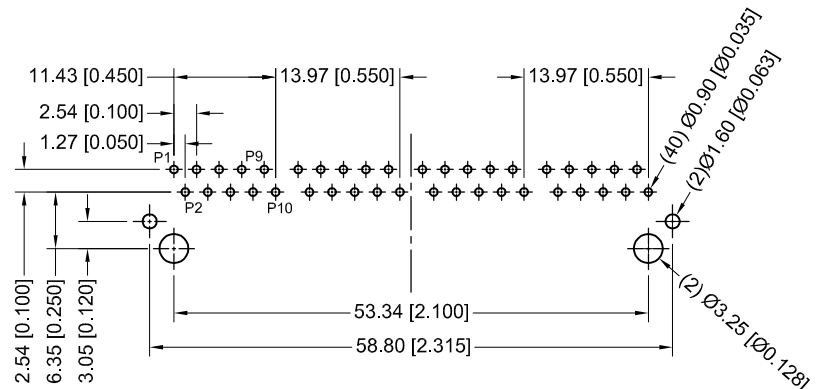

3. ELECTRICAL CHARACTERISTICS:

Cross Talk	Insertion Loss	Return Loss	CMRR	Hi-Pot Test
1MHz-100MHz	1MHz-100MHz	1MHz-40MHz	1MHz-100MHz	1500VAC or 2250VDC
-30dB (Max)	-1dB (Max)	-16dB (Max)	-30dB (Min)	(P1,P2):(J1,J2) (P3,P4):(J3,J6) (P7,P8):(J4,J5) (P9,P10):(J7,J8)



1. MECHANICAL DIMENSIONS:

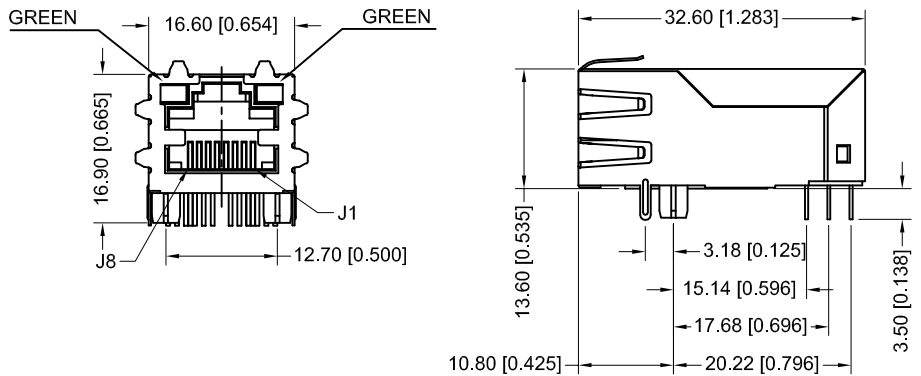

**10/100/1000 Mbps, With LED, Latch-Up,
12P, 8C Shielded**

PART NO	GOLD PLATING THICKNESS
A60-112-233P471	GOLD FLASH PLATING
A60-113-233P471	15 MICRO INCHES OF GOLD
A60-114-233P471	30 MICRO INCHES OF GOLD

2. SCHEMATIC:

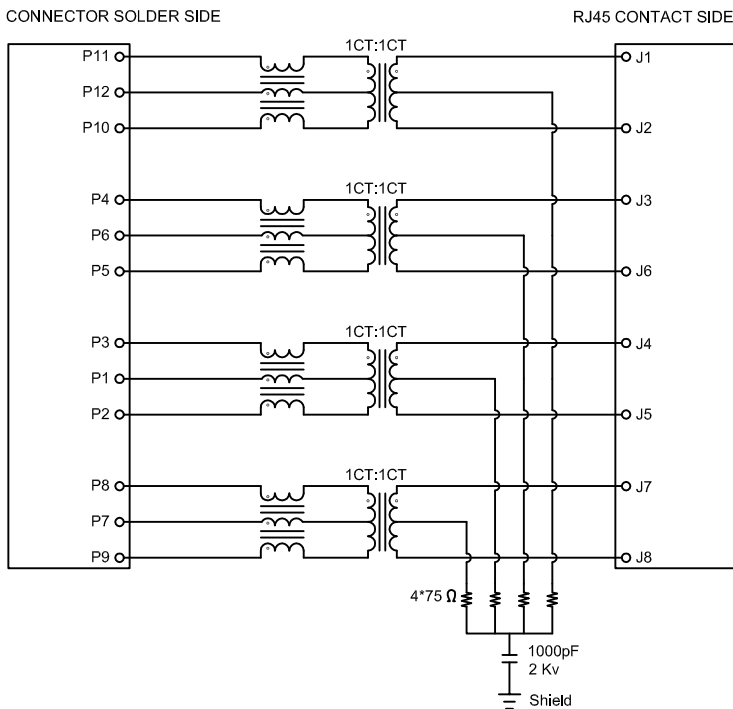

4. PCB LAYOUT (Top View)

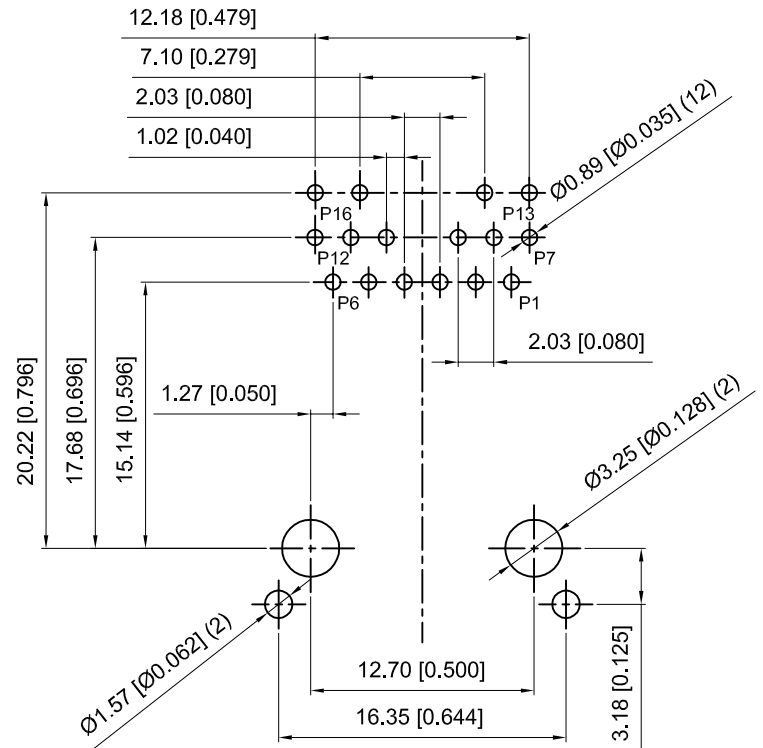

3. ELECTRICAL CHARACTERISTICS:

Cross Talk	Insertion Loss	Return Loss		CMRR	Isolation PHY
1MHz-100MHz	1MHz-100MHz	1MHz-40MHz	60MHz-80MHz	1MHz-100MHz	2250 VDC
-30dB (Min)	-1dB (Max)	-16dB (Min)	-10dB (Min)	-30dB (Min)	PHY Side to Line Side



1. MECHANICAL DIMENSIONS:

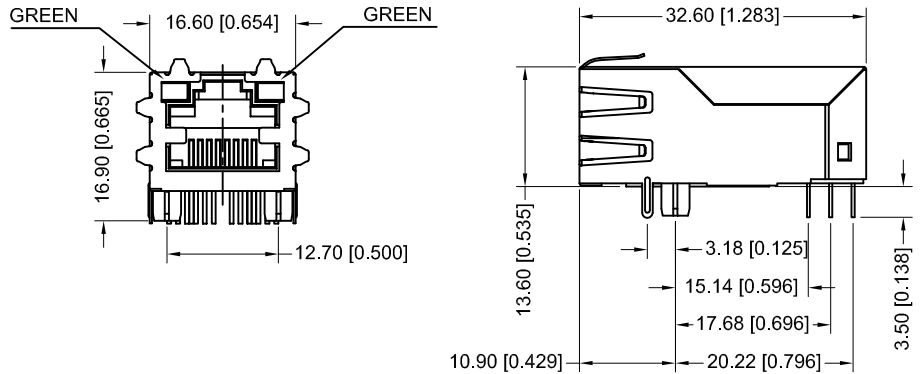

**10/100/1000 Mbps - 12 Core, With LED,
Latch-Up, 12P, 8C Shielded**

PART NO	GOLD PLATING THICKNESS
A61-112-233P4C3	GOLD FLASH PLATING
A61-113-233P4C3	15 MICRO INCHES OF GOLD
A61-114-233P4C3	30 MICRO INCHES OF GOLD

2. SCHEMATIC:

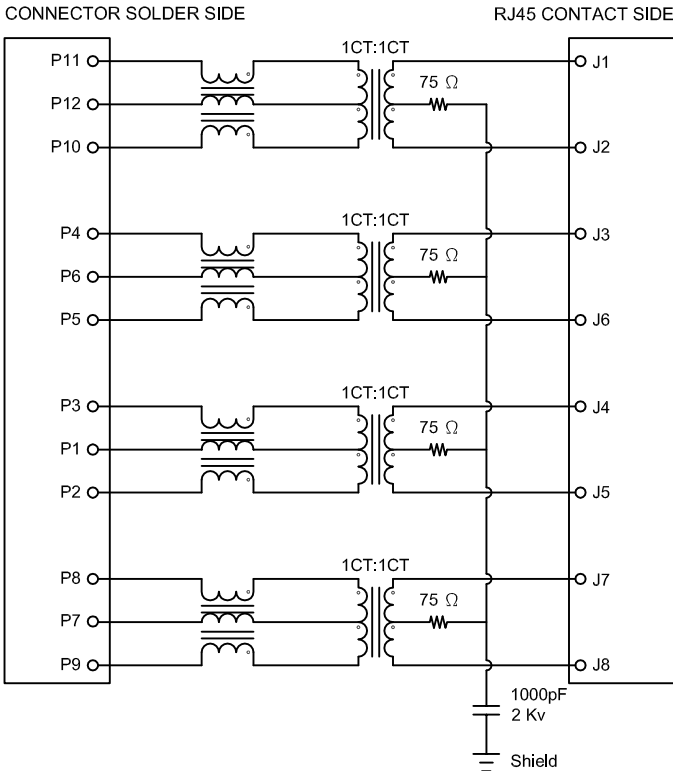

4. PCB LAYOUT (Top View)

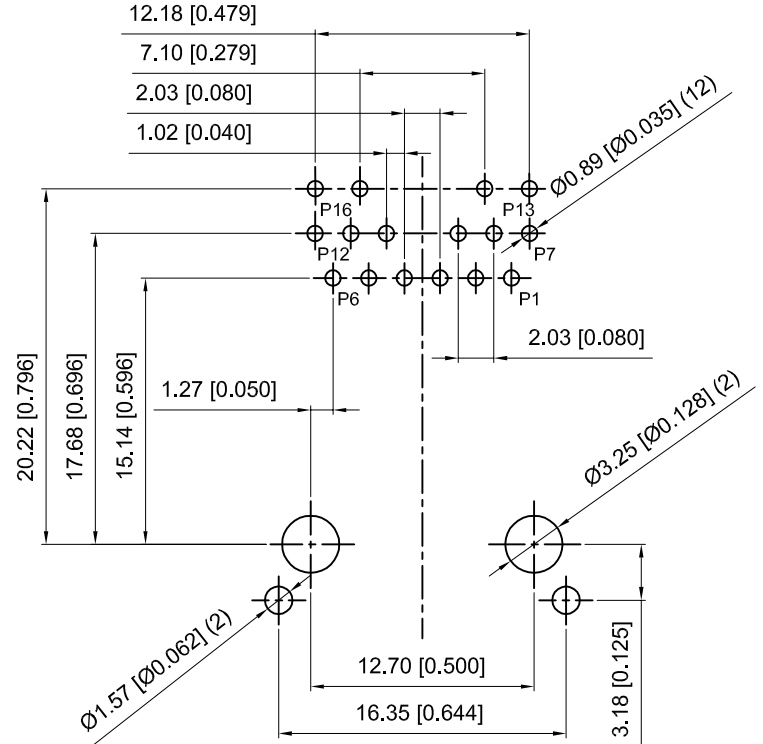

3. ELECTRICAL CHARACTERISTICS:

Cross Talk	Insertion Loss	Return Loss		CMRR	Hi-Pot Test	
1MHz-100MHz	1MHz-100MHz	1MHz-40MHz	60MHz-80MHz	1MHz-100MHz	1500VAC or 2250VDC	
-30dB (Min)	-1dB (Max)	-16dB (Min)	-10dB (Min)	-30dB (Min)	(P11,P10):(J1,J2) (P4,P5):(J3,J6)	(P3,P2):(J4,J5) (P8,P9):(J7,J8)

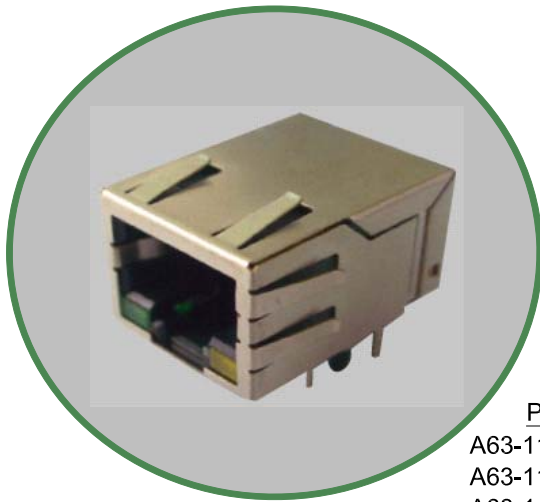

PART NO
 A63-112-331P4D2
 A63-113-331P4D2
 A63-114-331P4D2

10/100 Mbps, With LED, Latch-Down
10P, 8C, Shielded

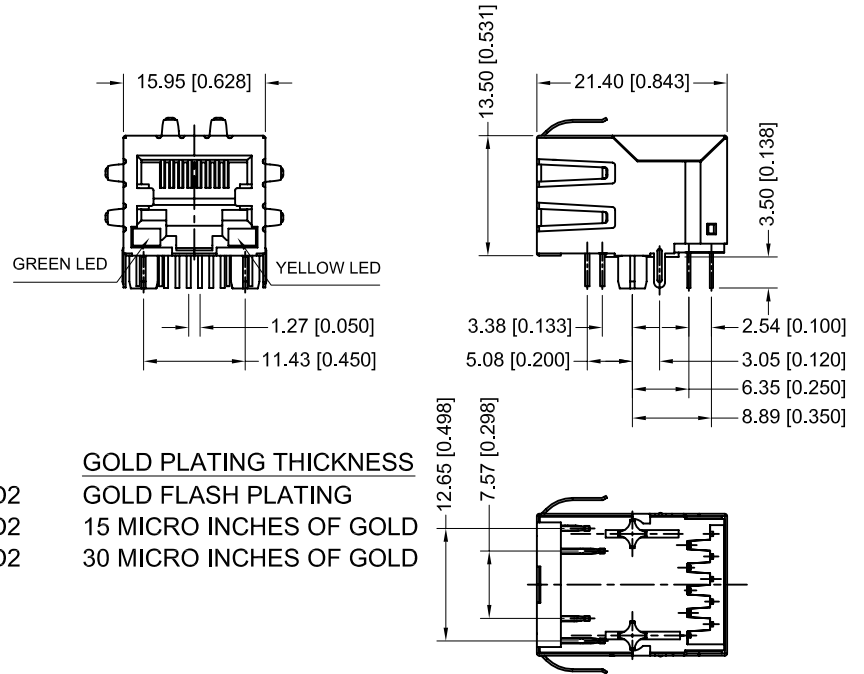

2. SCHEMATIC:

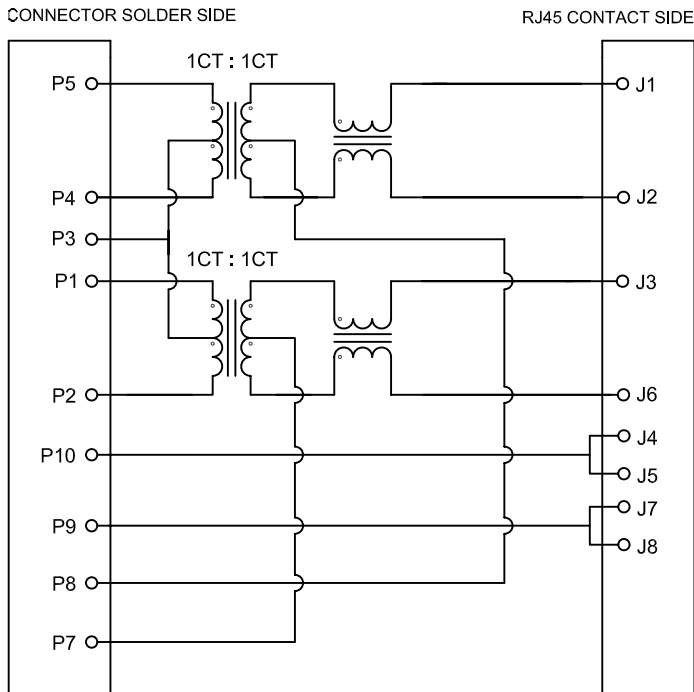

4. PCB LAYOUT (Top View)

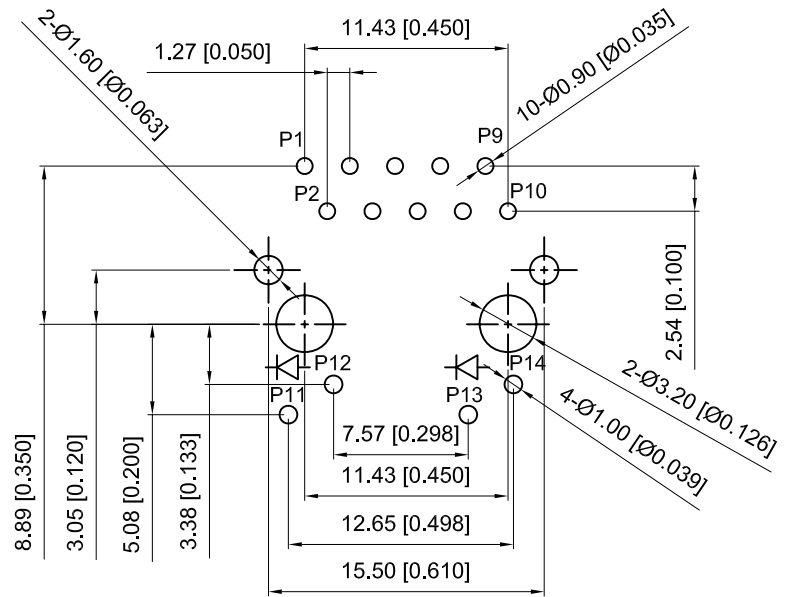

3. ELECTRICAL CHARACTERISTICS:

Cross Talk	Insertion Loss	Return Loss	CMRR	Hi-Pot Test		
1MHz-100MHz	0.1MHz-100MHz	1MHz-30MHz	60MHz-80MHz	30MHz-100MHz	1500VAC or 2250VDC	
-35dB (Typ)	-1.2dB (Max)	-18dB (Min)	-12dB (Min)	-30dB (Typ)	(P5,P4): (J1,J2)	(P1,P2): (J3,J6)

1. MECHANICAL DIMENSIONS:

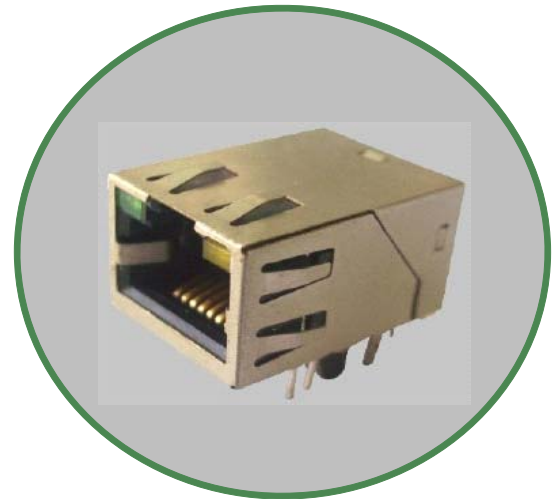
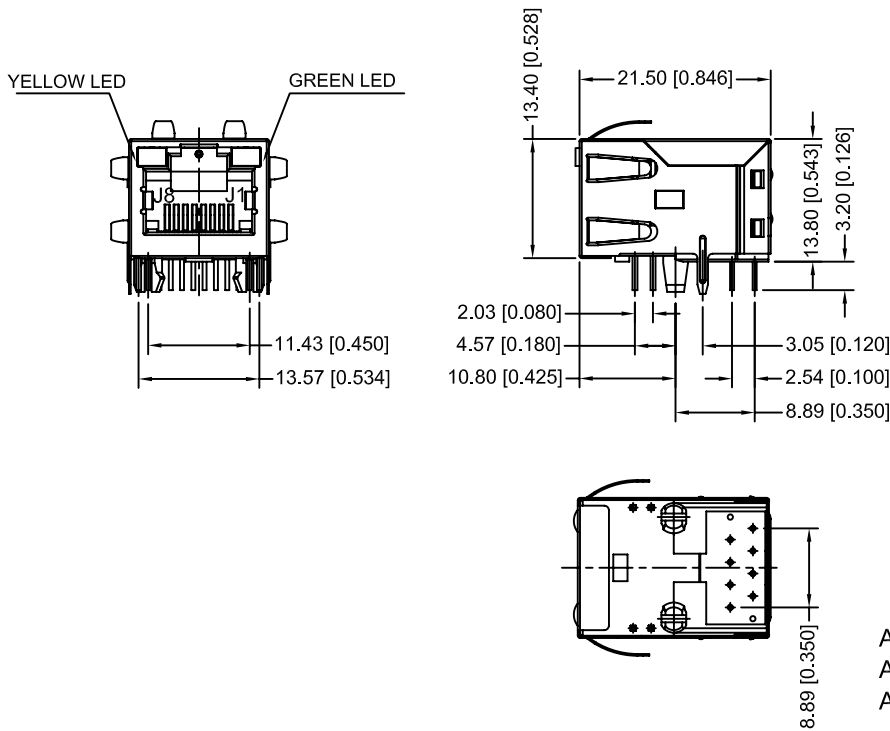

10/100Mbps, With LED, Latch-Up 8P, 8C, Shielded

PART NO	GOLD PLATING THICKNESS
A63-112-213N491	GOLD FLASH PLATING
A63-113-213N491	15 MICRO INCHES OF GOLD
A63-114-213N491	30 MICRO INCHES OF GOLD

2. SCHEMATIC:

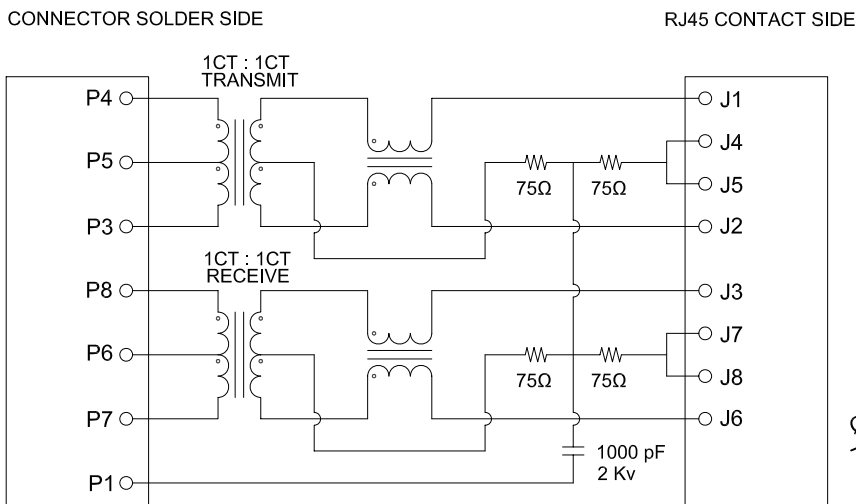

4. PCB LAYOUT (Top View)

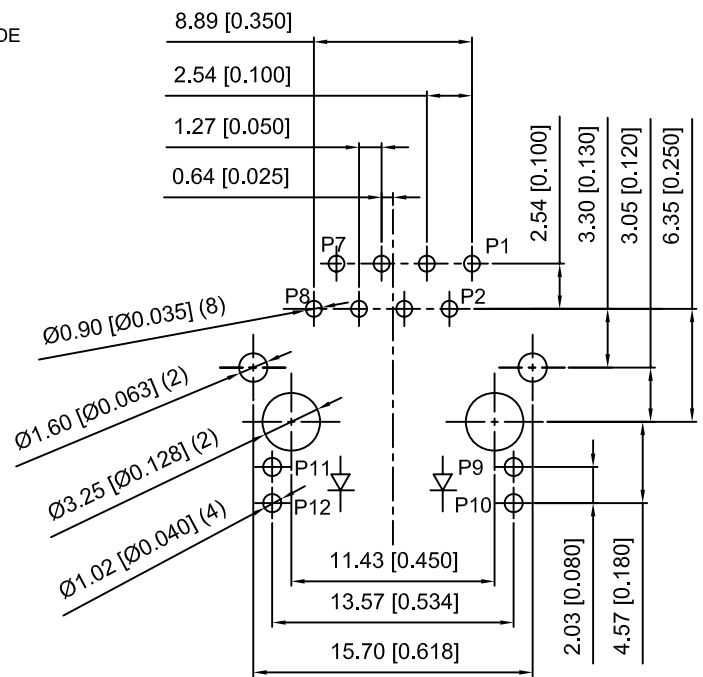

3. ELECTRICAL CHARACTERISTICS:

Cross Talk	Insertion Loss	Return Loss		CMRR	Hi-Pot Test	
1MHz-100MHz	0.1MHz-100MHz	1MHz-30MHz	60MHz-80MHz	30MHz-100MHz	1500VAC or 2250VDC	
-35dB (Typ)	-1.2dB (Max)	-18dB (Min)	-12dB (Min)	-30dB (Typ)	(P4,P3): (J1,J2)	(P8,P7): (J3,J6)

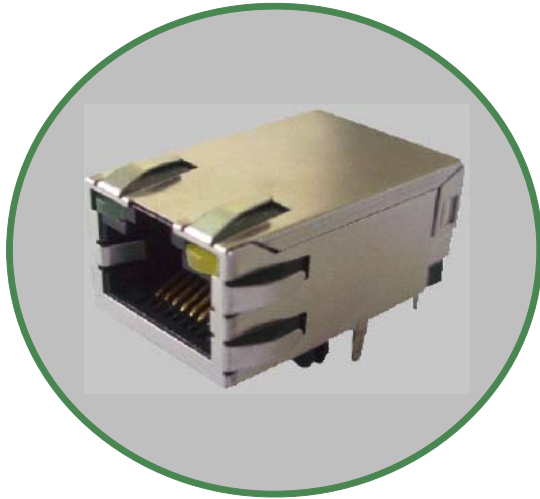

1. MECHANICAL DIMENSIONS:

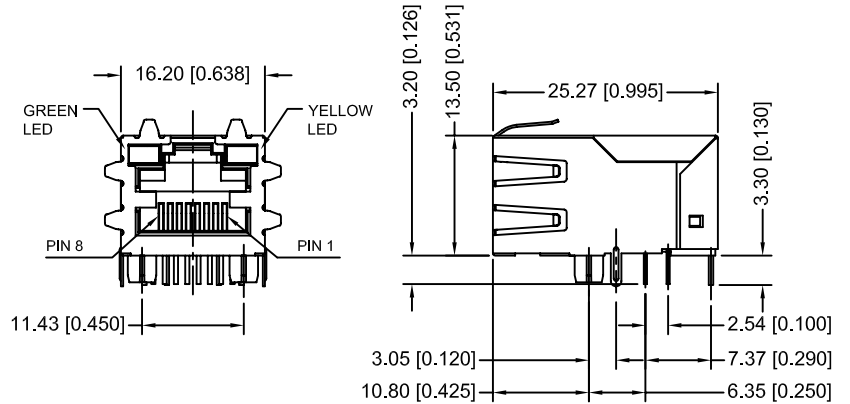

**10/100 Mbps, With LED, Latch-Up
8P, 8C, Shielded**

PART NO	GOLD PLATING THICKNESS
A63-112-231N435	GOLD FLASH PLATING
A63-113-231N435	15 MICRO INCHES OF GOLD
A63-114-231N435	30 MICRO INCHES OF GOLD

2. SCHEMATIC:

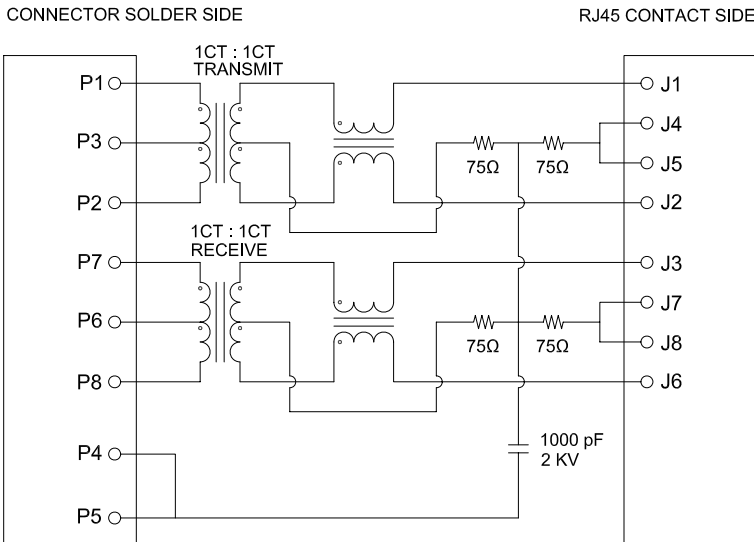

4. PCB LAYOUT (Top View)

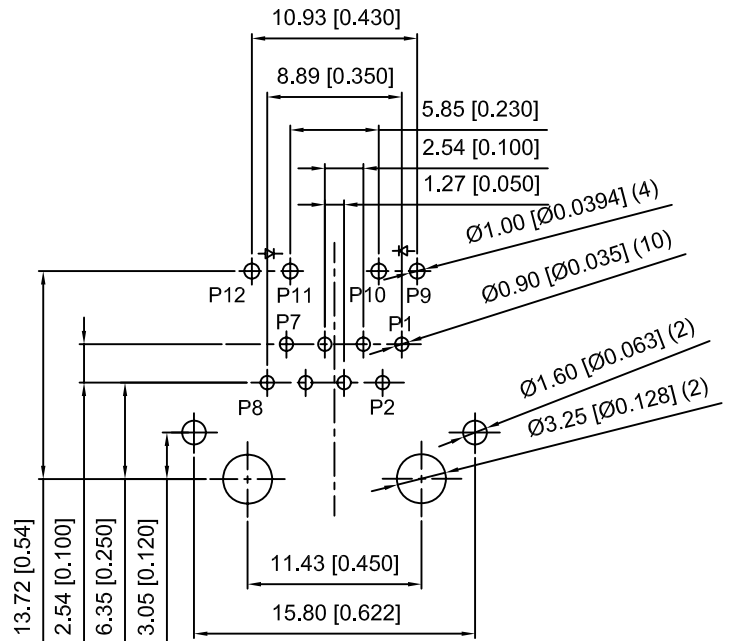

3. ELECTRICAL CHARACTERISTICS:

Cross Talk	Insertion Loss	Return Loss		CMRR	Hi-Pot Test
1MHz-100MHz	0.1MHz-100MHz	1MHz-30MHz	60MHz-80MHz	1MHz-100MHz	1500VAC or 2250VDC
-35dB (Typ)	-1.2dB (Max)	-18dB (Min)	-12dB (Min)	-30dB (Typ)	(P1,P2): (P7,P8): (J1,J2) (J3,J6)

1. MECHANICAL DIMENSIONS:

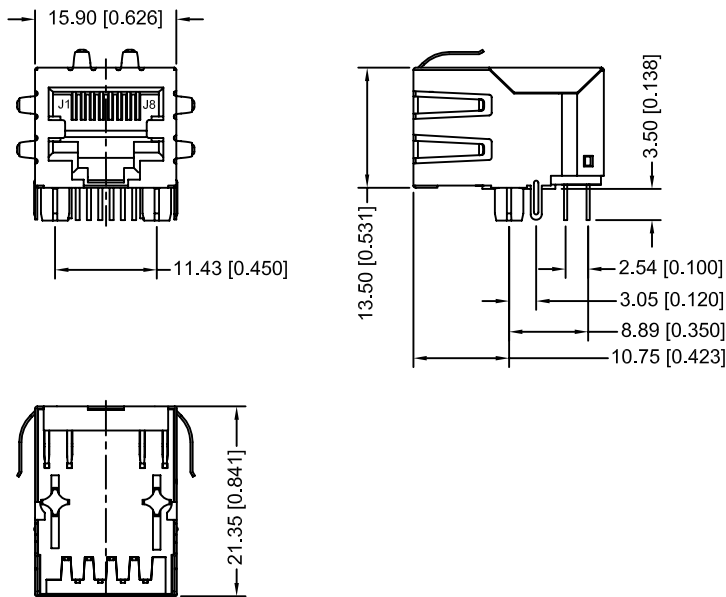

10/100 Mbps, Without LED, Latch-Down 8P, 8C, Shielded

PART NO	GOLD PLATING THICKNESS
A63-112-300P422	GOLD FLASH PLATING
A63-113-300P422	15 MICRO INCHES OF GOLD
A63-114-300P422	30 MICRO INCHES OF GOLD

2. SCHEMATIC:

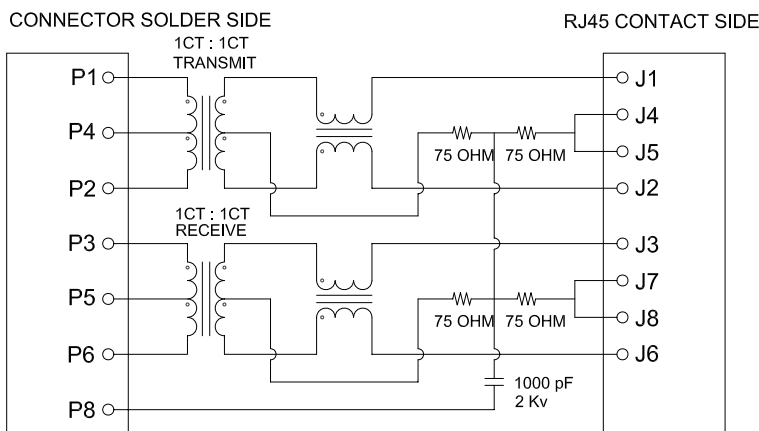

4. PCB LAYOUT (Top View)

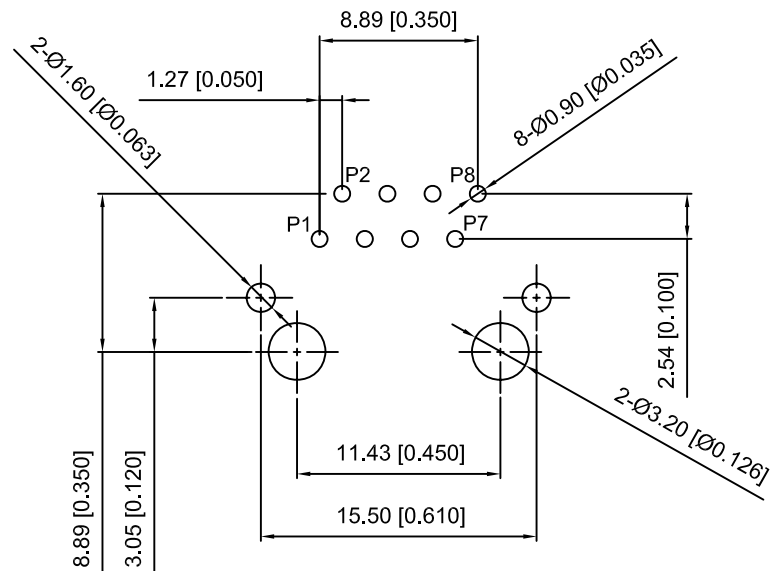

3. ELECTRICAL CHARACTERISTICS:

Cross Talk	Insertion Loss	Return Loss		CMRR	Hi-Pot Test	
1MHz-100MHz	0.1MHz-100MHz	1MHz-30MHz	60MHz-80MHz	30MHz-100MHz	1500VAC or 2250VDC	
-35dB (Typ)	-1.2dB (Max)	-18dB (Min)	-12dB (Min)	-30dB (Typ)	(P1,P2): (J1,J2)	(P3,P6): (J3,J6)

1. MECHANICAL DIMENSIONS:



**10/100 Mbps, With LED, Latch-Down
8P, 8C, Shielded**

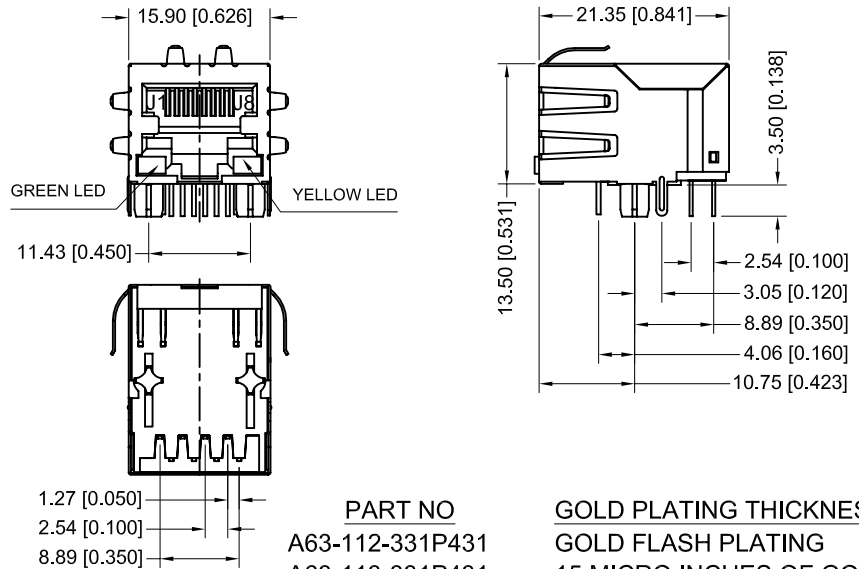

PART NO
A63-112-331P431
A63-113-331P431
A63-114-331P431

GOLD PLATING THICKNESS
GOLD FLASH PLATING
15 MICRO INCHES OF GOLD
30 MICRO INCHES OF GOLD

2. SCHEMATIC:

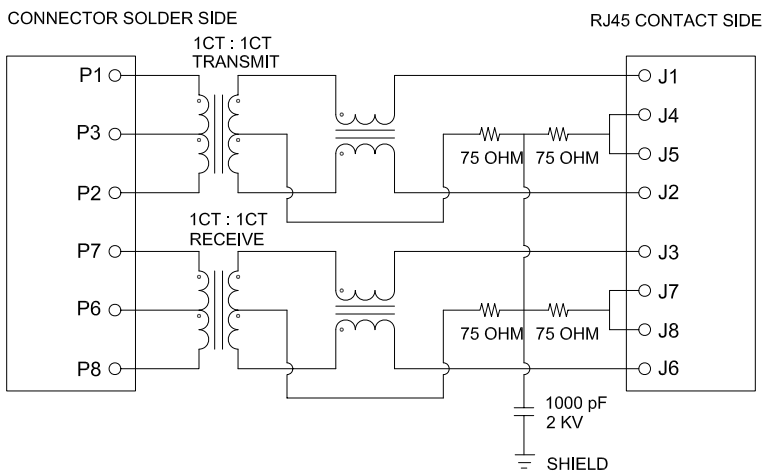

4. PCB LAYOUT (Top View)

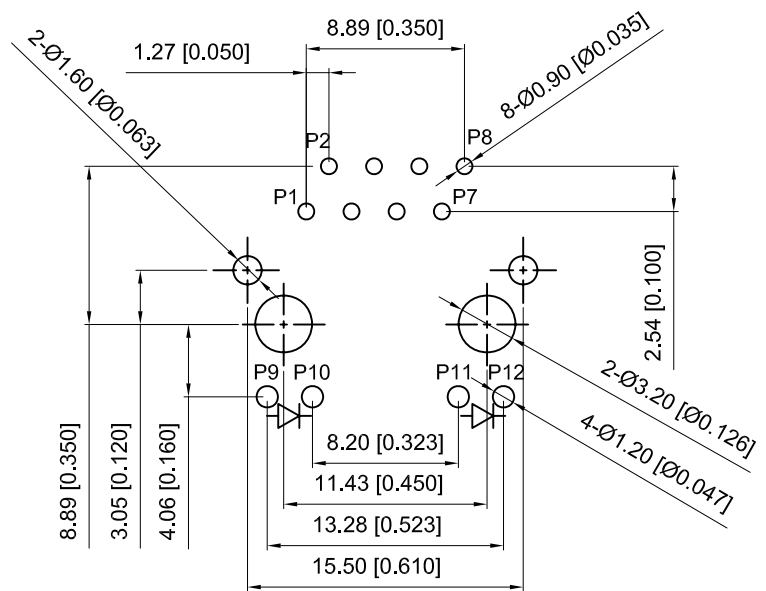

3. ELECTRICAL CHARACTERISTICS:

Cross Talk	Insertion Loss	Return Loss		CMRR	Hi-Pot Test	
1MHz-100MHz	0.1MHz-100MHz	1MHz-30MHz	60MHz-80MHz	30MHz-100MHz	1500VAC or 2250VDC	
-35dB (Typ)	-1.2dB (Max)	-18dB (Min)	-12dB (Min)	-30dB (Typ)	(P1,P2): (J1,J2)	(P7,P8): (J3,J6)

1. MECHANICAL DIMENSIONS:

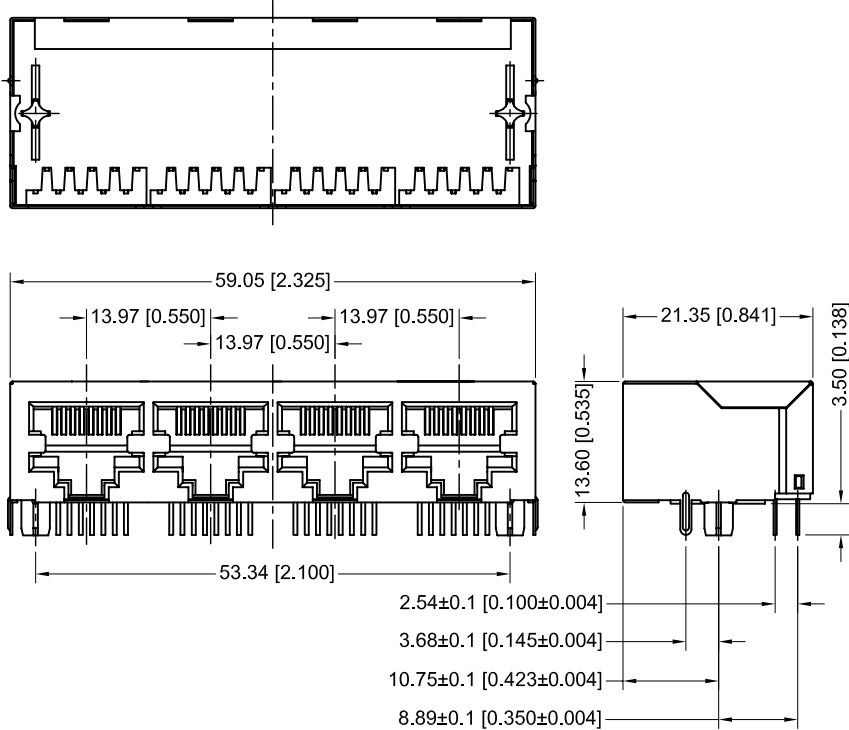

**10/100 Mbps, Without LED, Latch-Down
 8P, 8C, Shielded**

PART NO	GOLD PLATING THICKNESS
A63-142-300N161	GOLD FLASH PLATING
A63-143-300N161	15 MICRO INCHES OF GOLD
A63-144-300N161	30 MICRO INCHES OF GOLD

2. SCHEMATIC:

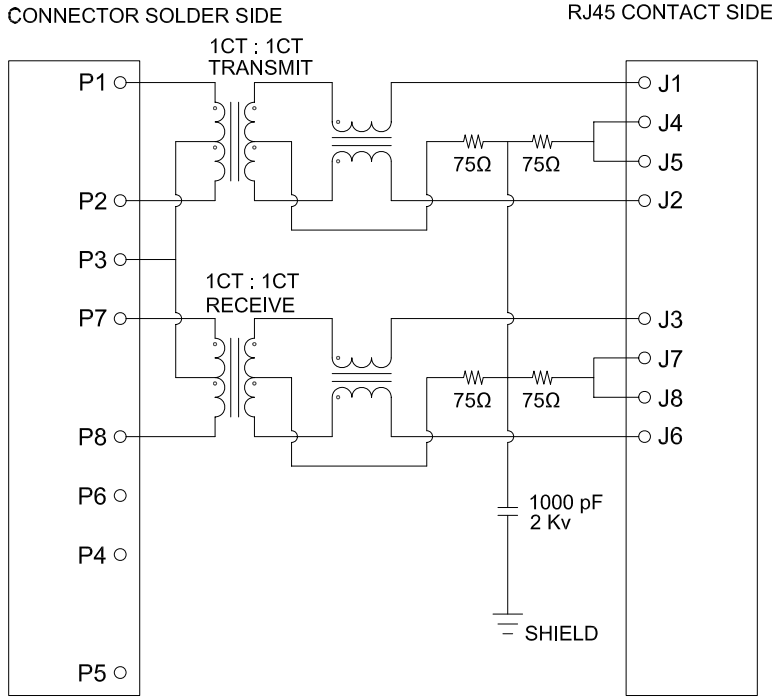

4. PCB LAYOUT (Top View)

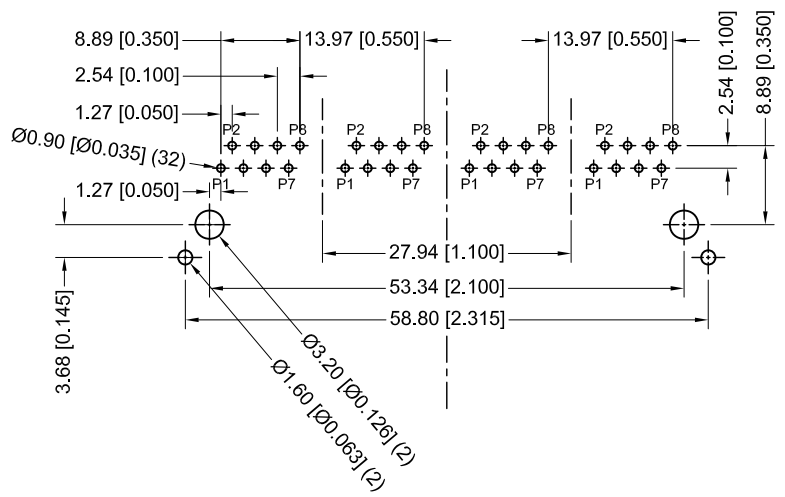

3. ELECTRICAL CHARACTERISTICS:

Cross Talk	Insertion Loss	Return Loss		CMRR	Hi-Pot Test	
1MHz-100MHz	0.1MHz-80MHz	1MHz-30MHz	30MHz-80MHz	30MHz-100MHz	1500VAC	
-35dB (Typ)	-1.2dB (Max)	-18dB (Min)	-12dB (Min)	-30dB (Typ)	(P1,P2): (J1,J2)	(P7,P8): (J3,J6)

1. MECHANICAL DIMENSIONS:

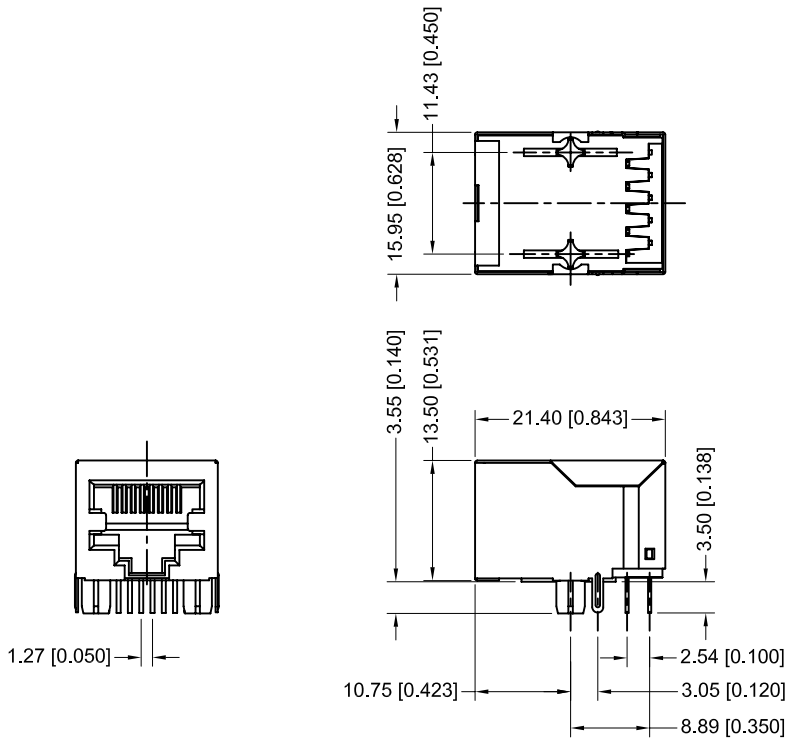

10/100 Mbps, Without LED, Latch-Down 8P, 8C, Shielded

PART NO	GOLD PLATING THICKNESS
A63-112-300P131	GOLD FLASH PLATING
A63-113-300P131	15 MICRO INCHES OF GOLD
A63-114-300P131	30 MICRO INCHES OF GOLD

2. SCHEMATIC:

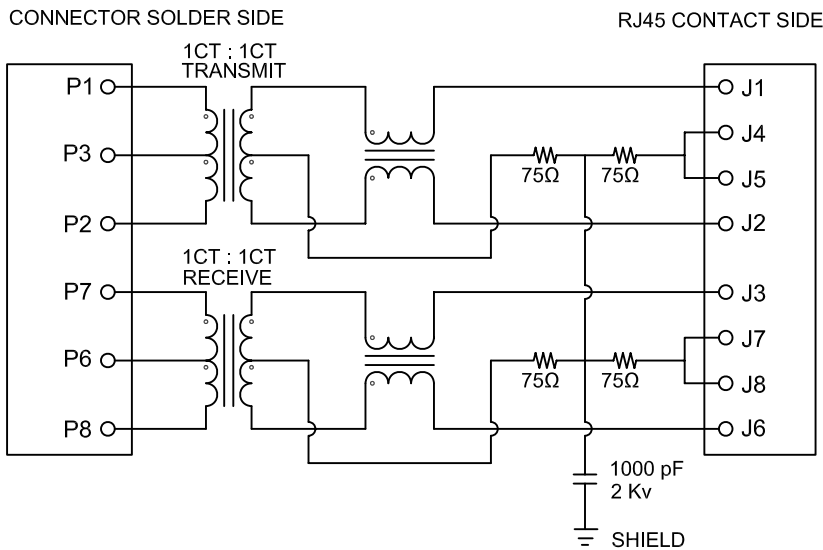

4. PCB LAYOUT (Top View)

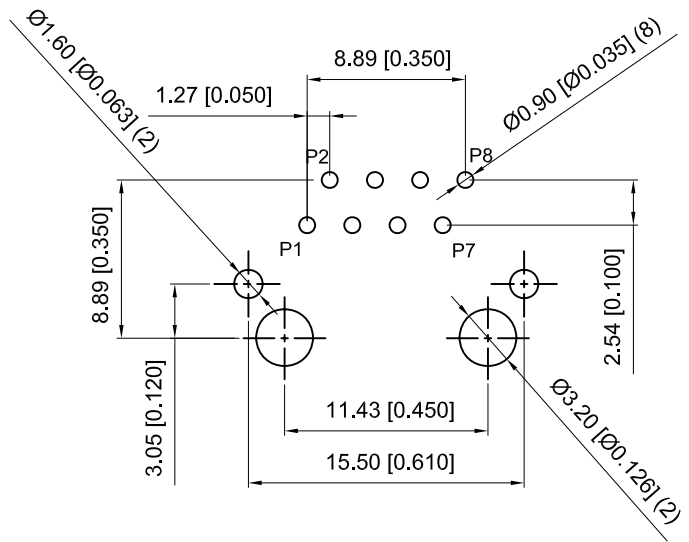

3. ELECTRICAL CHARACTERISTICS:

Cross Talk	Insertion Loss	Return Loss		CMRR	Hi-Pot Test	
1MHz-100MHz	0.1MHz-100MHz	1MHz-30MHz	60MHz-80MHz	30MHz-100MHz	1500VAC or 2250VDC	
-35dB (Typ)	-1.2dB (Max)	-18dB (Min)	-12dB (Min)	-30dB (Typ)	(P1,P2): (J1,J2)	(P7,P8): (J3,J6)

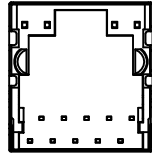
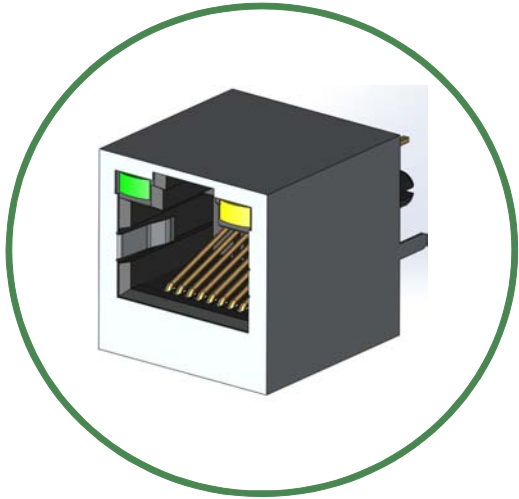

1. MECHANICAL DIMENSIONS:

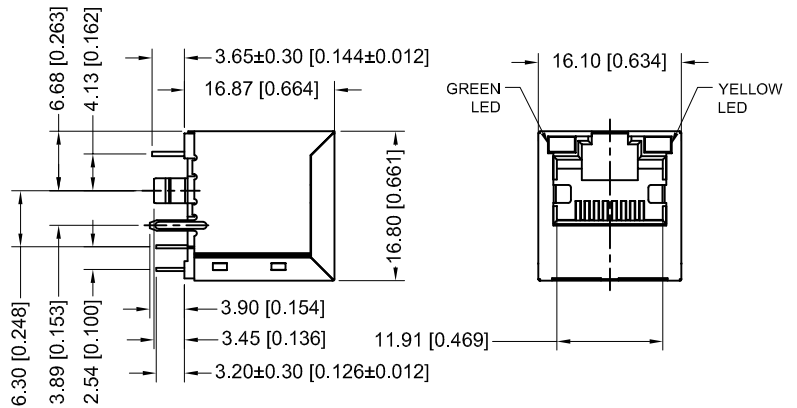

PART NO	GOLD PLATING THICKNESS
A63-112-431P112	GOLD FLASH PLATING
A63-113-431P112	15 MICRO INCHES OF GOLD
A63-114-431P112	30 MICRO INCHES OF GOLD

**10/100 Mbps, With LED, Vertical, Latch-Up
8P, 8C, Shielded**

2. SCHEMATIC:

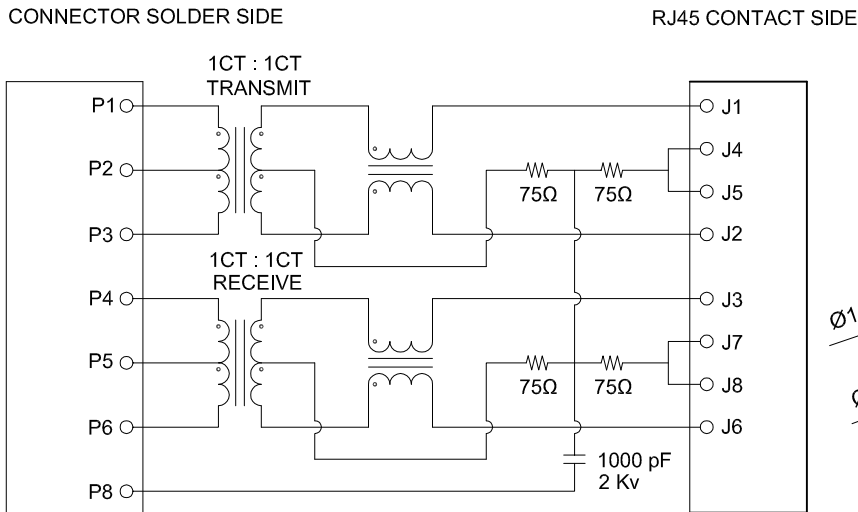

4. PCB LAYOUT (Top View)

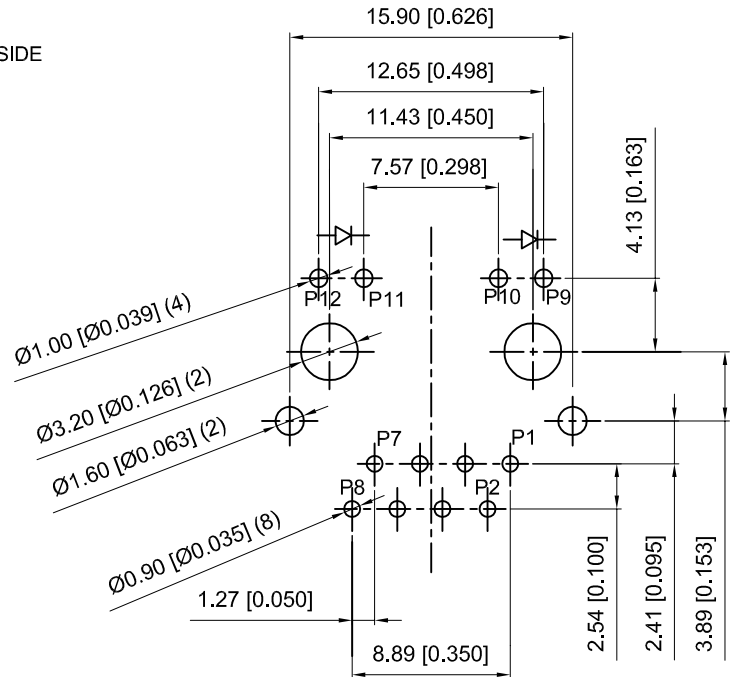

3. ELECTRICAL CHARACTERISTICS:

Cross Talk	Insertion Loss	Return Loss	CMRR	Hi-Pot Test		
1MHz-100MHz	0.1MHz-80MHz	1MHz-30MHz	30MHz-80MHz	30MHz-100MHz	1500VAC	
-35dB (Typ)	-1.2dB (Max)	-18dB (Min)	-12dB (Min)	-30dB (Typ)	(P1,P3): (J1,J2)	(P4,P6): (J3,J6)

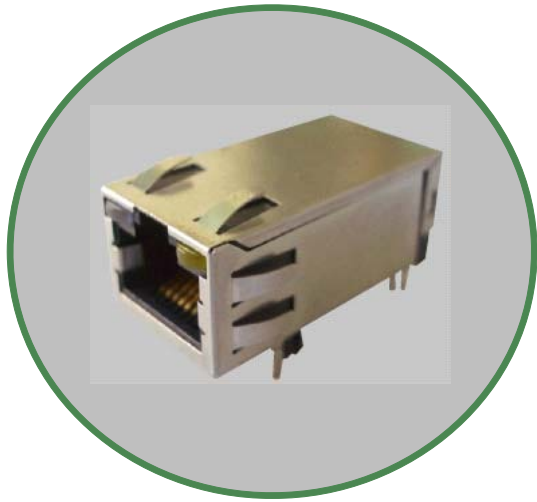

1. MECHANICAL DIMENSIONS:

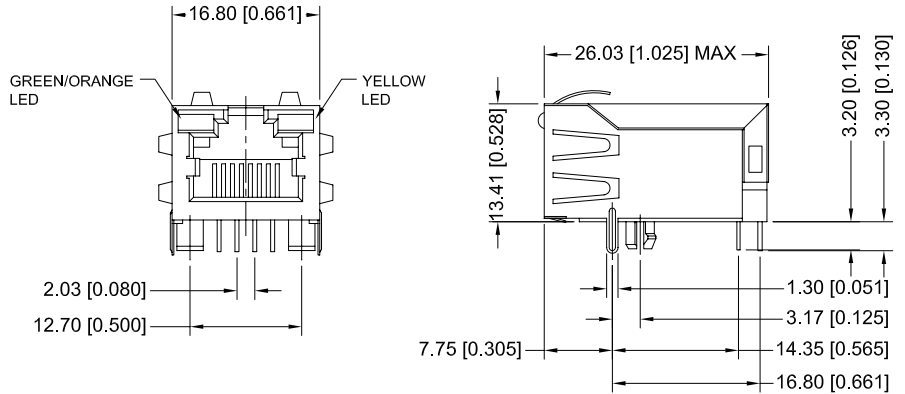

10/100 Mbps- 5 Core, With LED
Latch-Up, 6P, 8C, Shielded

PART NO	GOLD PLATING THICKNESS
A64-112-271P521	GOLD FLASH PLATING
A64-113-271P521	MICRO INCHES OF GOLD
A64-114-271P521	30 MICRO INCHES OF GOLD

2. SCHEMATIC:

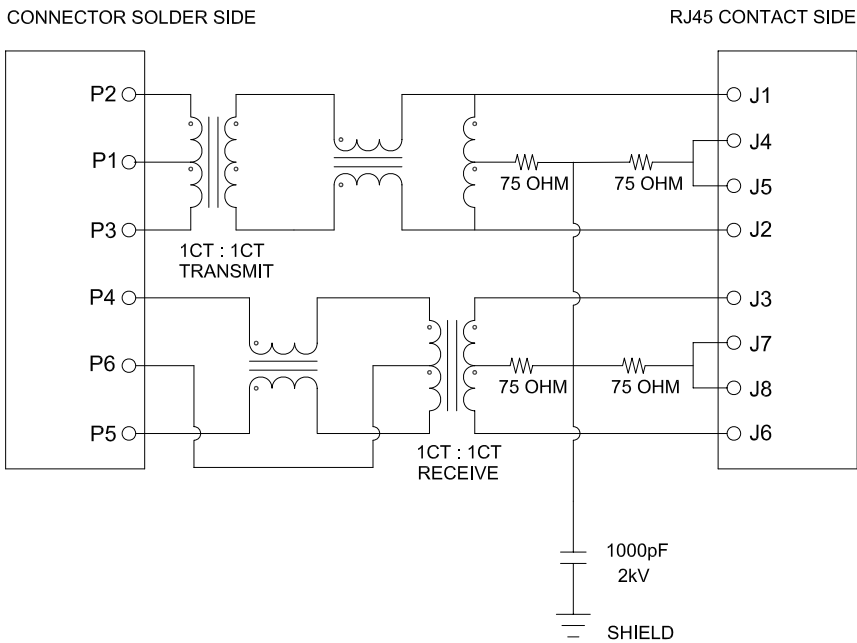

4. PCB LAYOUT (Top View)

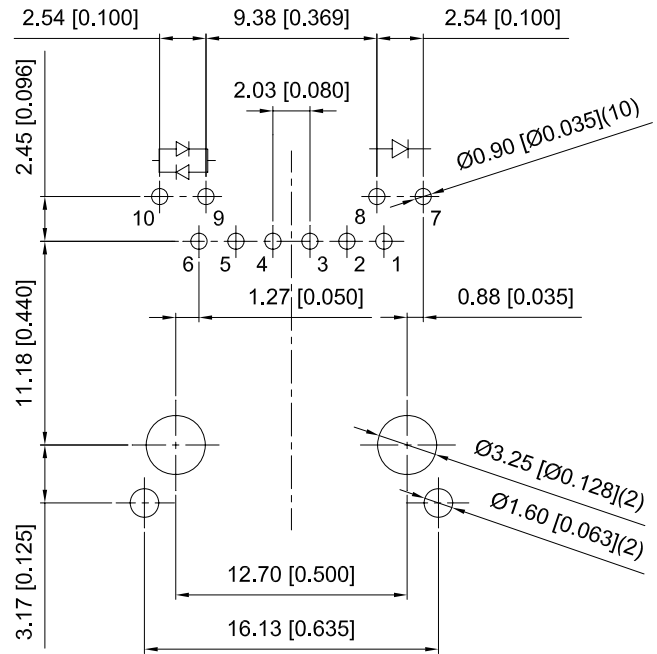

3. ELECTRICAL CHARACTERISTICS:

Cross Talk	Insertion Loss	Return Loss		CMRR	Hi-Pot Test	
1MHz-100MHz	1MHz-100MHz	1MHz-30MHz	60MHz-80MHz	1MHz-100MHz	1500VAC (2sec)	
-35dB (Typ)	-1.2dB (Max)	-18dB (Min)	-12dB (Min)	-30dB (Min)	(P2,P3): (J1,J2)	(P4,P5): (J3,J6)

1. MECHANICAL DIMENSIONS:

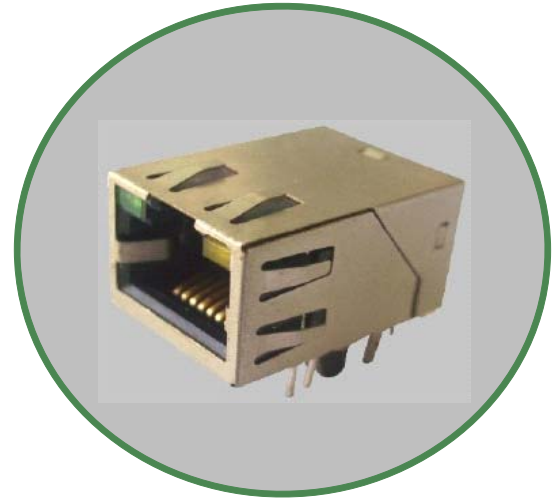
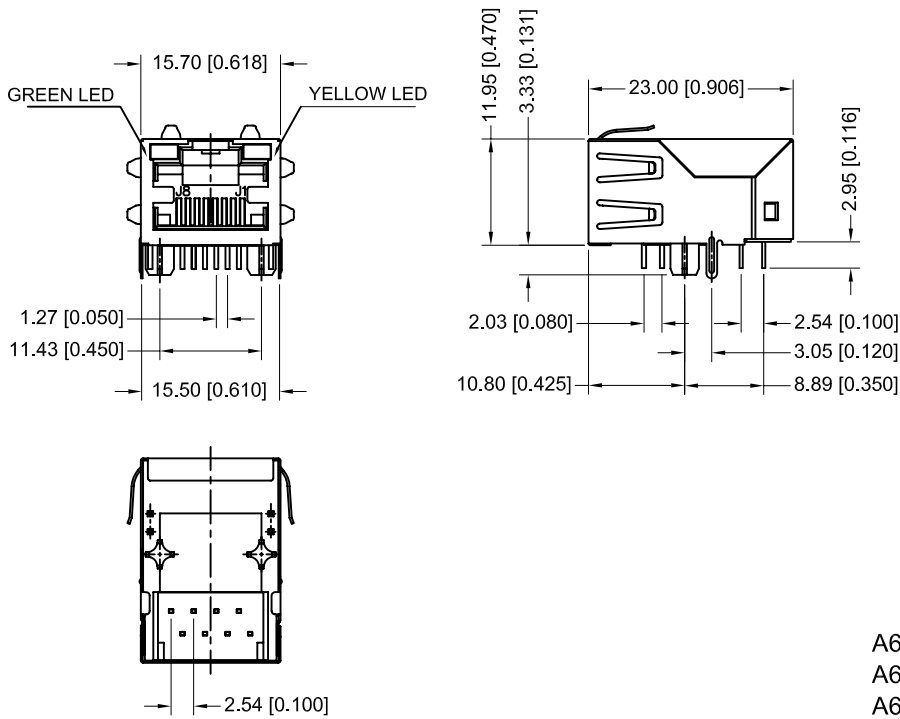

**10/100 Mbps- 5 Core, With LED
Latch-Up, 8P, 8C, Shielded**

PART NO	GOLD PLATING THICKNESS
A64-112-231N411	GOLD FLASH PLATING
A64-113-231N411	15 MICRO INCHES OF GOLD
A64-114-231N411	30 MICRO INCHES OF GOLD

2. SCHEMATIC:

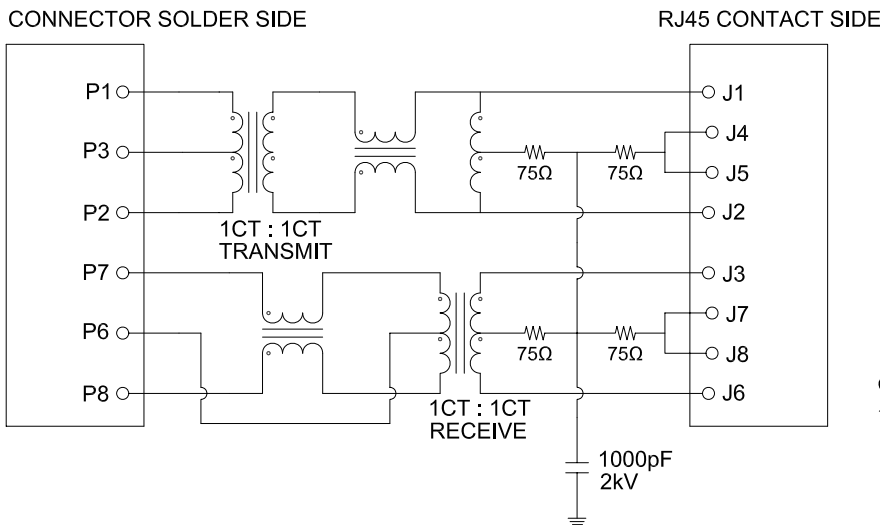

4. PCB LAYOUT (Top View)

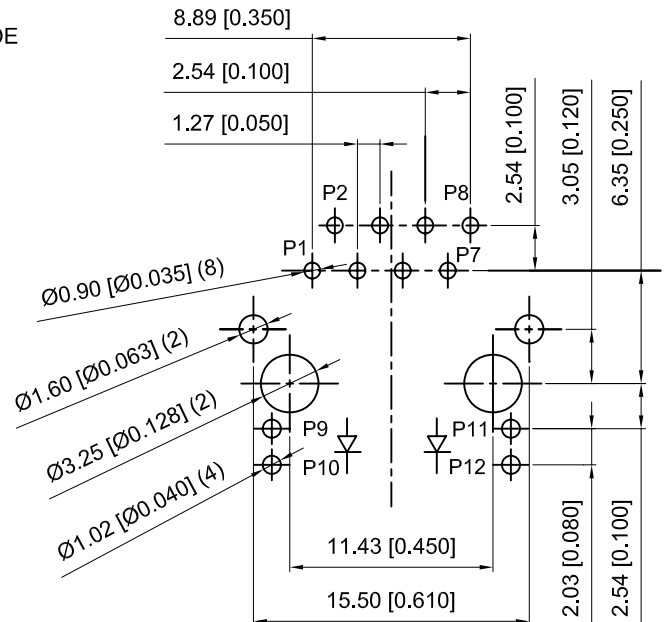

3. ELECTRICAL CHARACTERISTICS:

Cross Talk	Insertion Loss	Return Loss		CMRR	Hi-Pot Test	
1MHz-100MHz	0.1MHz-80MHz	1MHz-30MHz	30MHz-80MHz	30MHz-100MHz	1500VAC or 2250VDC	
-35dB (Typ)	-1.1dB (Max)	-18dB (Min)	-12dB (Min)	-30dB (Typ)	(P1,P2): (J1,J2)	(P7,P8): (J3,J6)