



Chipsmall Limited consists of a professional team with an average of over 10 year of expertise in the distribution of electronic components. Based in Hongkong, we have already established firm and mutual-benefit business relationships with customers from,Europe,America and south Asia,supplying obsolete and hard-to-find components to meet their specific needs.

With the principle of “Quality Parts,Customers Priority,Honest Operation,and Considerate Service”,our business mainly focus on the distribution of electronic components. Line cards we deal with include Microchip,ALPS,ROHM,Xilinx,Pulse,ON,Everlight and Freescale. Main products comprise IC,Modules,Potentiometer,IC Socket,Relay,Connector.Our parts cover such applications as commercial,industrial, and automotives areas.

We are looking forward to setting up business relationship with you and hope to provide you with the best service and solution. Let us make a better world for our industry!



Contact us

Tel: +86-755-8981 8866 Fax: +86-755-8427 6832

Email & Skype: info@chipsmall.com Web: www.chipsmall.com

Address: A1208, Overseas Decoration Building, #122 Zhenhua RD., Futian, Shenzhen, China



Thumbwheel Switch

A7□

A Wide Selection of Models: Thumbwheel- or Push-operated, Decimal or Hexadecimal

- A wide selection ranging from miniature models that save space to large models with enhanced readability and operability.
- Select models with the specifications desired, or where long life and reliability are critical.
- Additional new models prevent value changes due to accidental pressing of buttons. Pen-push or locking types are available.

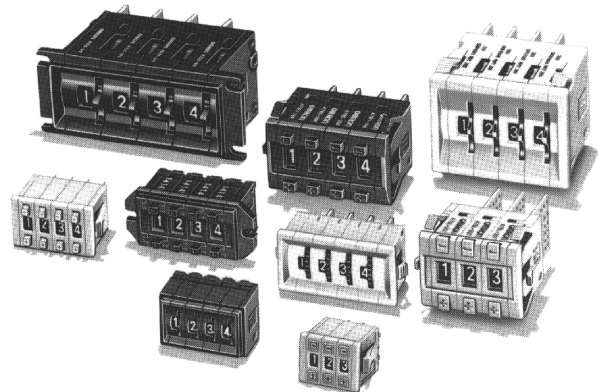

Ordering Information

■ Push-operated Switches

| Model and mounting | Terminals | Color | Output code | | | | | |
|---------------------------------|---------------------------------------|---------------|-------------------------|------------------------------------|---|--|--|--|
| | | | 03 (decimal code) | 06 (binary coded decimal) | 07 (binary coded decimal with component adding provision) | 19 (decimal code with component adding provision) | 54 (binary coded hexadecimal) | 55 (binary coded hexadecimal with component adding provision) |
| A7DP-2 (pen-push) Snap-in | PCB terminal | Light gray | --- | A7DP-206 | --- | --- | --- | --- |
| | | Black | --- | A7DP-206-1 | --- | --- | --- | --- |
| A7D-2 Snap-in | PCB terminal | Light gray | --- | A7D-206 | --- | --- | --- | --- |
| | | Black | --- | A7D-206-1 | --- | --- | --- | --- |
| A7D-1 Screw mounting | PCB terminal | Light gray | --- | A7D-106 | --- | --- | --- | --- |
| | | Black | --- | A7D-106-1 | --- | --- | --- | --- |
| A7CN Screw mounting | PCB terminal | Light gray | --- | --- | --- | --- | --- | --- |
| | | Black | --- | A7CN-106-1 | --- | --- | --- | --- |
| A7CN Snap-in | PCB terminal | Light gray | --- | A7CN-206 | --- | --- | --- | --- |
| | | Black | --- | A7CN-206-1 | --- | --- | --- | --- |
| A7CNL (Locking) Snap-in | PCB terminal | Light gray | --- | A7CN-L206 | --- | --- | --- | --- |
| | | Black | --- | A7CN-L206-1 | --- | --- | --- | --- |
| A7BL (locking) Snap-in | Solder terminal (see note 1) | Light gray | --- | A7BL-206 | A7BL-207 | --- | --- | --- |
| | | Black | --- | A7BL-206-1 | A7BL-207-1 | --- | --- | --- |
| A7BS Snap-in | Solder terminal (see note 1) | Light gray | (A7BS-203) | A7BS-206 | A7BS-207 | (A7BS-219) | A7BS-254 | A7BS-255 |
| | | Black | (A7BS-203-1) | A7BS-206-1 | A7BS-207-1 | (A7BS-219-1) | A7BS-254-1 | A7BS-255-1 |

| Model and mounting | Terminals | Color | Output code | | | | | |
|---|------------------------------|------------|-------------------------|------------------------------------|---|--|--|--|
| | | | 03 (decimal code) | 06 (binary coded decimal) | 07 (binary coded decimal with component adding provision) | 19 (decimal code with component adding provision) | 54 (binary coded hexadecimal) | 55 (binary coded hexadecimal with component adding provision) |
| A7BS-20□-S (with external Stoppers) Snap-in | Solder terminal (see note 1) | Light gray | --- | A7BS-206-S | A7BS-207-S | --- | --- | --- |
| | | Black | --- | A7BS-206-S-1 | A7BS-207-S-1 | --- | --- | --- |
| A7PS Snap-in | Solder terminal (see note 1) | Light gray | A7PS-203 | A7PS-206 | A7PS-207 | A7PS-219 | A7PS-254 | A7PS-255 |
| | | Black | A7PS-203-1 | A7PS-206-1 | A7PS-207-1 | A7PS-219-1 | A7PS-254-1 | A7PS-255-1 |
| A7PH (long life) Snap-in | Solder terminal (see note 1) | Light gray | A7PH-203 | A7PH-206 | A7PH-207 | A7PH-219 | --- | --- |
| | | Black | A7PH-203-1 | A7PH-206-1 | A7PH-207-1 | A7PH-219-1 | --- | --- |

Note: 1. Terminals for use with PCBs are also available. Inquire for details.

2. Please inquire about Code 01 models with +, - displays (-PM) and models in parentheses.

Accessories (Order Separately)

| Applicable Switch Unit | Color | End Caps | Spacers (see note 1) | Connectors | |
|-----------------------------------|------------|-----------|----------------------|------------------|---------------|
| | | | | Solder terminals | PCB terminals |
| A7D-1 | Light gray | A7D-1M | A7D-1PA | --- | --- |
| | Black | A7D-1M-1 | A7D-1PA-1 | --- | --- |
| A7DP-2/A7D-2 | Light gray | A7D-2M | A7D-2PA | --- | --- |
| | Black | A7D-2M-1 | A7D-2PA-1 | --- | --- |
| A7CN Screw mounting | Light gray | --- | --- | --- | --- |
| | Black | A7CN-1M-1 | A7CN-1P□-1 | --- | --- |
| A7CN/A7CN-L Snap-in | Light gray | A7CN-2M | A7CN-2P□ | --- | --- |
| | Black | A7CN-2M-1 | A7CN-2P□-1 | --- | --- |
| A7BL/A7BS/A7BS-20□-S (see note 2) | Light gray | A7B-M | A7B-PA | A7B-C | A7B-CP |
| | Black | A7B-M-1 | A7B-PA-1 | --- | --- |
| A7PS | Light gray | A7P-M | A7P-PA | --- | --- |
| | Black | A7P-M-1 | A7P-PA-1 | --- | --- |
| A7PH | Light gray | A7P-M | A7P-PA | --- | --- |
| | Black | A7P-M-1 | A7P-PA-1 | --- | --- |

Note: 1. Spacers come standard without characters. Refer to page 30 for characters to be included.

2. Stopper pin comes standard.

Model: A7BS-S

(Stopper pins come in pairs. They are shipped free initially. Please make special arrangements for maintenance.)

■ Thumbwheel Switches

| Models and mounting | Terminals | Color | Output code | | | |
|---|--------------------|---------------|--|----------------------|---------------------------------|---|
| | | | 01 (binary code with +, – displayed) | 03 (decimal code) | 06 (binary coded decimal) | 07 (binary coded decimal with component adding provision) |
| A7MD/ A7MD-□□-D (see note 1) Fastens to panel via printed circuit board. | PCB terminal | Black | --- | --- | A7MD-106-P-09 | --- |
| | | | A7MD-106-P-09-D (see note 1) | | | |
| A7MA-1 Screw mounting | Solder terminal | Black | (A7MA-106-PM) | (A7MA-103) | A7MA-106 | A7MA-107 |
| | PCB terminal | | (A7MA-P2-PM) | | A7MA-106-P2 | A7MA-107-P2 |
| A7MA-2 Snap-in | Solder terminal | Light gray | (A7MA-206-PM) | --- | A7MA-206 | A7MA-207 |
| | | Black | (A7MA-206-PM-1) | | A7MA-206-1 | A7MA-207-1 |
| | PCB terminal | Light gray | (A7MA-206-P2-PM) | | A7MA-206-P2 | A7MA-207-P2 |
| | | Black | (A7MA-206-P2- PM-1) | | A7MA-206-P2-1 | A7MA-207-P2-1 |
| A7SS Screw mounting | Solder terminal | Black | (A7SS-106-PM) | A7SS-103 | A7SS-106 | A7SS-107 |
| A7AS Snap-in | Solder terminal | Light gray | (A7AS-206-PM) | A7AS-203 | A7AS-206 | A7AS-207 |
| | | Black | (A7AS-206-PM-1) | A7AS-203-1 | A7AS-206-1 | A7AS-207-1 |

- Note:** 1. Indicates models with built-in diodes.
2. Please inquire about models in parentheses.

| Model and mounting | Terminals | Color | Output code | | | | | |
|---------------------------|--------------------|---------------|-----------------|--|-------------------------------|--|---|--|
| | | | 08 (06 + 22) | 13 (double-side d PCB version of 06) | 14 (06 with odd parity) | 19 (decimal code with component adding provision) | 22 (06 with complement ary code) | 36 (double-side d PCB version of 07) |
| A7SS Screw mounting | Solder terminal | Black | --- | --- | --- | A7SS-119 | --- | --- |
| A7AS Snap-in | Solder terminal | Light gray | --- | --- | --- | A7AS-219 | (A7AS-222) | --- |
| | | Black | | | | A7AS-219-1 | (A7AS-222-1) | |

- Note:** Inquire about models in parentheses.

Accessories (Order Separately)

| Applicable Switch Unit | Color | End Caps (left-right set) | Spacers (see note 2) | Connectors | |
|------------------------|------------|---------------------------|----------------------|-----------------|--------------|
| | | | | Solder terminal | PCB terminal |
| A7MD(-D) | Black | A7MD-1M | A7MD-PA | --- | --- |
| A7MA-1 | Black | A7M-1M | A7M-1PA | --- | --- |
| A7MA-2 | Light gray | A7M-2M | A7M-2PA | --- | --- |
| | Black | A7M-2M-1 | A7M-2PA-1 | | |
| A7SS | Black | A7SS-M | --- | --- | --- |
| A7AS | Light gray | A7AS-M | --- | --- | --- |
| | Black | A7AS-M-1 | --- | | |

- Note:** 1. Spacers serve the same purpose as spare Switch Units, except that their widths differ. Refer to page 30, *Dimensions*, for further information.
2. Spacers come standard without characters. Refer to page 30 for characters to be included.

■ Ordering Procedure

Configurations

The Thumbwheel Switch is generally used in the configuration shown below.

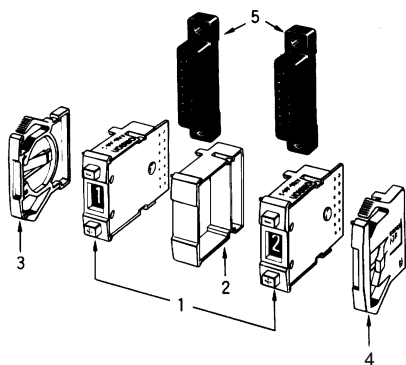

- 1: Switch Unit refers to the Switch itself. As each digit is independent of the others, a number of Switch Units are assembled to make up just the number of digits needed.
- 2: Spacers can be used in case the number of digits change due to a change in specifications. When units for time and length must be displayed, the necessary letters and symbols can be printed or stamped. The stamping shown in the following table can be produced. Inquire for details.

Stamping

| | | | | | | | |
|---------------|----------------|-----|-----|-----|----------|----|----|
| Symbol | A | B | C | D | E | F | G |
| Stamp | No designation | SEC | MIN | H | g | kg | mm |
| Symbol | H | J | K | L | Q | T | U |
| Stamp | cm | m | °C | PCS | x 10 SEC | 0 | • |

- 3, 4: End Caps/Side Plates: These are used at both ends of the Switch Unit to insure a solid mount of each Switch Unit to a panel. Left and right plates make a set.
- 5: Connectors: Since the Switch Unit snaps right into a Connector, accomplishing both attachment and wiring in a single action, connections, maintenance and inspection are greatly simplified.

Ordering

Standard products such as the Switch Units and End Caps are not factory-assembled for shipment. Place orders as shown below, specifying the model and number of Switch Units.

Ordering Example:

| Figure | Product name | Model | Number of Units |
|--------|------------------|------------|-----------------|
| 1 | Switch Unit | A7BS-206-1 | 2 |
| 2 | Spare Unit | A7B-PA-1 | 1 |
| 3 | Attachment Board | A7B-M-1 | 1 set |
| 4 | | | |
| 5 | Connector | A7B-CP | 2 |

Special Characters and Symbols for Dial Displays

Dials can be ordered with special characters or symbols as well as with Stoppers attached. Ask your OMRON sales representatives.

Positive, Negative Dials

To order dials marked with +, -, +, -, ... in place of the numerals 0 to 9, add the suffix -PM to the model number. (Refer to page 18 for details)

Example: A7PS-203-PM

Attaching Stoppers

Stoppers are used to limit the display range from 0 to 9 down to 0 to 5, for example.

Add -S□□ to the suffix, specifying the range in the blanks.

Example: A7PS-203-S05

Units to which Stoppers can be attached are the A7DP, A7D, A7BL, A7PS, A7PH, A7SS, and A7AS.

On the outside of the A7BS-□-S is a Stopper Pin with which the user can make any setting.

The A7CN-2, A7CN-1, A7CN-L, A7MD, and A7MA cannot be equipped with Stoppers.

Specifications

■ Ratings/Characteristics

Push-operated Switches

| Item | | A7DP-2/A7D-1 /A7D-2 | A7CN/A7CN-L | A7BL/A7BS /A7BS-20□-S | A7PS | A7PH |
|--|---|--|--|---|-----------------------------------|---------------------------|
| Switching capacity (resistive load) | | 5 to 30 VDC 1 mA to 0.1 A | 5 to 28 VDC 1 mA to 0.1 A | | 125 VAC/28 VDC 10 μA to 0.15 A | |
| Continuous carry current | | 100 mA | 1 A max. | | 3 A max. | |
| Contact resistance | | 200 mΩ max. | | | | |
| Insulation resistance | Between non-connected terminals | 10 MΩ min. (at 250 VDC) | | 10 MΩ min. (at 500 VDC) | | 100 MΩ min. (at 500 VDC) |
| | Between terminal and non-current carrying part | 100 MΩ min. (at 500 VDC) | | 1,000 MΩ min. (at 500 VDC) | | |
| Dielectric strength | Between non-connected terminals | 250 VAC, 50/60 Hz for 1 min | 200 VAC, 50/60 Hz for 1 min | 600 VAC, 50/60 Hz for 1 min | | |
| | Between terminal and non-current carrying part | 1,000 VAC, 50/60 Hz for 1 min | | | | |
| Vibration resistance | Malfunction | 10 to 55 Hz, 1.5-mm double amplitude | | | | |
| Shock resistance | Malfunction | 500 m/s ² min. (approx. 50G) | 490 m/s ² min. (approx. 50G) | 500 m/s ² min. (approx. 50G) | | |
| Life expectancy | Mechanical | 30,000 operations min. | | 100,000 operations min. | | 2,000,000 operations min. |
| | Electrical | 20,000 operations min. | | 50,000 operations min. | | 1,000,000 operations min. |
| Ambient temperature (with no icing) | | Operating: -10°C to 70°C Storage: -20°C to 80°C | Operating: -10°C to 65°C Storage: -20°C to 80°C | | | |
| Ambient humidity | | Operating: 45% to 85% | Operating: 35% to 85% | Operating: 45% to 85% | | |
| Max. operating force | | 3.45 N (350 gf) | 4.41 N (450 gf) | 5.4 N (550 gf) | 6.35 N (650 g) | |

Thumbwheel Switches

| Item | | A7MD/A7MD-□□-D (see note 1) | A7MA-1/A7MA-2 | A7SS | A7AS |
|-------------------------------------|--|--|---------------|--|------|
| Switching capacity (resistive load) | | 5 to 28 VDC 1 mA to 0.1 A | | 50 VAC to 28 VDC 1 mA to 0.1 A | |
| Continuous carry current | | 1 A max. | | | |
| Contact resistance | | 200 mΩ max., 10 Ω max. (see note 2) | 200 mΩ max. | | |
| Insulation resistance (see note 1) | Between non-connected terminals | 10 MΩ min. (at 500 VDC) | | | |
| | Between terminal and non-current carrying part | 1,000 MΩ min. (at 500 VDC) | | | |
| Dielectric strength (see note 1) | Between non-connected terminals | 200 VAC, 50/60 Hz for 1 min | | 600 VAC, 50/60 Hz for 1 min | |
| | Between terminal and non-current carrying part | 1,000 VAC, 50/60 Hz for 1 min | | | |
| Vibration resistance | Malfunction | 10 to 55 Hz, 1.5-mm double amplitude | | | |
| Shock resistance | Malfunction | 200 m/s ² min. (approx. 20G) | | 490 m/s ² min. (approx. 50G) | |
| Life expectancy | Mechanical | 30,000 operations min. | | 1,000,000 operations min. | |
| | Electrical | 20,000 operations min. | | 50,000 operations min. | |
| Ambient temperature (with no icing) | | Operating: -10°C to 65°C Storage: -20°C to 80°C | | Operating: -40°C to 85°C Storage: -40°C to 85°C | |
| Ambient humidity | | Operating: 45% to 85% | | | |
| Max. operating force max. | | 2.95 N (300 gf) | | 3.9 N (400 gf) | |

Note: 1. For A7MD(-D) with diode, the dielectric strength was measured at display of "0."

2. Contact resistance for A7MD(-D) with diode was evaluated at 6 to 8 VDC, 0.1 A. Reverse-direction voltage was 35 V (min.).

Operation

■ Output Codes

Output code types are distinguished according to terminal numbers on Switch Units.

How to Read Output Codes

Example for Output Code 06

For example, when the dial position is "3," the common terminal C on the Switch Unit is connected to terminals 1 and 2, as indicated by the solid dots in the output code table. The internal circuitry is shown below.

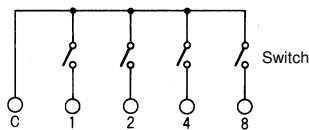

Reference

The internal circuit with diodes for the A7MD-106-P-09 is shown here, but the output condition and concepts are the same as those to the left.

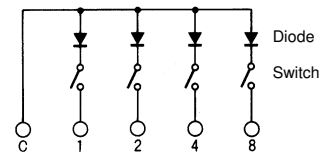

When a Switch is inserted into a Connector, e.g., for the A7BS, the common terminal C becomes connector terminal 2, and terminals 1 and 2 become connector terminals 4 and 5, respectively.

06: Binary-coded Decimal Output, Single-sided Board

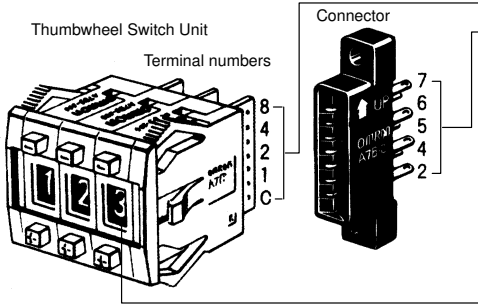

| Model | Switch Unit or Connector | Common terminal number | Terminals connected to common | | | |
|-------|--------------------------|------------------------|-------------------------------|---|---|---|
| A7BS | Switch Unit | C | 1 | 2 | 4 | 8 |
| | Connector | 2 | 4 | 5 | 6 | 7 |
| Dial | 0 | | | | | |
| | 1 | | • | | | |
| | 2 | | | • | | |
| | 3 | | • | • | | |
| | 4 | | | | • | |
| | 5 | | • | | • | |
| | 6 | | | • | • | |
| | 7 | | • | • | • | |
| | 8 | | | | | • |
| | 9 | | • | | | • |

The solid dot • indicates that the internal switch is ON.

Output Code Types

Decimal Code

03: Decimal Code Output

| Model | Switch Unit or Connector | Common terminal number | Terminals connected to common | | | | | | | | | | |
|------------------------------|--------------------------|------------------------|-------------------------------|---|---|---|---|---|---|---|----|----|--|
| A7SS A7AS A7PS A7PH | Switch Unit | C | 0 | 1 | 2 | 3 | 4 | 5 | 6 | 7 | 8 | 9 | |
| | Connector | 6 | 1 | 2 | 3 | 4 | 5 | 7 | 8 | 9 | 10 | 11 | |
| Dial | 0 | | • | | | | | | | | | | |
| | 1 | | | • | | | | | | | | | |
| | 2 | | | | • | | | | | | | | |
| | 3 | | | | | • | | | | | | | |
| | 4 | | | | | | • | | | | | | |
| | 5 | | | | | | | • | | | | | |
| | 6 | | | | | | | | • | | | | |
| | 7 | | | | | | | | | • | | | |
| | 8 | | | | | | | | | | • | | |
| | 9 | | | | | | | | | | | • | |

Binary Code

01: Binary Code Output (+, – Switching)

| Model | Switch Unit or Connector | Common terminal number | Terminals connected to common | | | |
|-------|--------------------------|------------------------|-------------------------------|---|---|---|
| Dial | + | | • | | • | |
| | – | | | • | | • |
| | : | | : | : | : | : |
| | – | | • | | • | • |

PM Models

- For models other than those listed on the left, use models with dials displaying “+, –, +, –, ..., –” instead of “0, 1, 2, ..., 9”.
- These models end with a -PM.
Example: A7BS-206-PM
The output codes and terminals are the same as the A7BS-206; however, binary code output is used between output terminal 1 and the common terminal.

19: Decimal Code Output with Component-adding Provision

| Model | Switch Unit or Connector | Common terminal number | Terminals connected to common | | | | | | | | | | |
|------------------------------|--------------------------|------------------------|-------------------------------|---|---|---|---|---|---|---|----|----|--|
| A7SS A7AS A7PS A7PH | Switch Unit | C | 0 | 1 | 2 | 3 | 4 | 5 | 6 | 7 | 8 | 9 | |
| | Connector | 6 | 1 | 2 | 3 | 4 | 5 | 7 | 8 | 9 | 10 | 11 | |
| Dial | 0 | | • | | | | | | | | | | |
| | 1 | | | • | | | | | | | | | |
| | 2 | | | | • | | | | | | | | |
| | 3 | | | | | • | | | | | | | |
| | 4 | | | | | | • | | | | | | |
| | 5 | | | | | | | • | | | | | |
| | 6 | | | | | | | | • | | | | |
| | 7 | | | | | | | | | • | | | |
| | 8 | | | | | | | | | | • | | |
| | 9 | | | | | | | | | | | • | |

Example of A7BS-206-PM

| Model | Switch Unit or Connector | Common terminal number | Terminals connected to common | | | |
|-------|--------------------------|------------------------|-------------------------------|---|---|---|
| | | | 1 | 2 | 4 | 8 |
| A7BS | Switch Unit | C | | | | |
| | Connector | 2 | 4 | 5 | 6 | 7 |
| Dial | + (0) | | | | | |
| | - (1) | | • | | | |
| | + (2) | | | • | | |
| | - (3) | | • | • | | |
| | + (4) | | | | • | |
| | - (5) | | • | | • | |
| | + (6) | | | • | • | |
| | - (7) | | • | • | • | |
| | + (8) | | | | | • |
| - (9) | | • | | | • | |

Note: 1. The solid dot • indicates that the internal switch is ON.
 2. Numbers enclosed in parentheses are the dial displays for the A7BS-206.

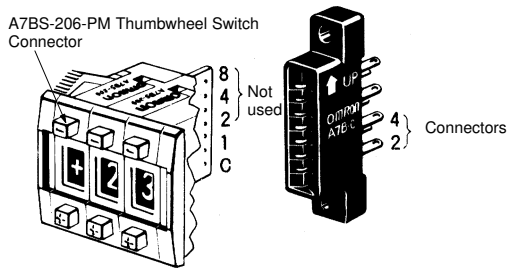

Binary Code Decimal

06: Binary-coded Decimal Output, Single-sided Board

| Model | Switch Unit or Connector | Common terminal number | Terminals connected to common | | | |
|--|--------------------------|------------------------|-------------------------------|---|---|----|
| | | | 1 | 2 | 4 | 8 |
| A7BL A7BS | Switch Unit | C | | | | |
| | Connector | 2 | 4 | 5 | 6 | 7 |
| A7MD (see note) A7MA (see note) A7SS A7DP A7D (see note) A7CN A7CN-L A7PS A7PH | Switch Unit | C | 1 | 2 | 4 | 8 |
| | Connector | 3 | 5 | 7 | 9 | 11 |
| Dial | 0 | | | | | |
| | 1 | | • | | | |
| | 2 | | | • | | |
| | 3 | | • | • | | |
| | 4 | | | | • | |
| | 5 | | • | | • | |
| | 6 | | | • | • | |
| | 7 | | • | • | • | |
| | 8 | | | | | • |
| 9 | | • | | | • | |

Note: There is no Connector on the A7MD, A7MA, A7D□, and A7C□.

22: Complementary Code of 06

| Model | Switch Unit or connector | Common terminal number | Terminals connected to common | | | |
|-------|--------------------------|------------------------|-------------------------------|---|---|---|
| | | | 1 | 2 | 4 | 8 |
| A7BS | Switch Unit | C | | | | |
| | Connector | 2 | 4 | 5 | 6 | 7 |
| Dial | 0 | | • | • | • | • |
| | 1 | | | • | • | • |
| | 2 | | • | | • | • |
| | 3 | | | | • | • |
| | 4 | | • | • | | • |
| | 5 | | | • | | • |
| | 6 | | • | | | • |
| | 7 | | | | | • |
| | 8 | | • | • | • | |
| 9 | | | • | • | | |

07: Binary-code Decimal Output with Component-adding Provision

| Model | Switch Unit or Connector | Common terminal number | Terminals connected to common | | | |
|---|--------------------------|------------------------|-------------------------------|---|---|----|
| A7BL A7BS | Switch Unit | C | 1 | 2 | 4 | 8 |
| | Connector | 1, 2 | 4 | 5 | 6 | 7 |
| A7MA (see note) A7SS A7AS A7PS A7PH | Switch Unit | C | 1 | 2 | 4 | 8 |
| | Connector | 1, 3 | 5 | 7 | 9 | 11 |
| Dial | 0 | | | | | |
| | 1 | | • | | | |
| | 2 | | | • | | |
| | 3 | | • | • | | |
| | 4 | | | | • | |
| | 5 | | • | | • | |
| | 6 | | | • | • | |
| | 7 | | • | • | • | |
| | 8 | | | | | • |
| | 9 | | • | | | • |

Note: There is no Connector on the A7MA.

Binary-coded Hexadecimal

54: Binary-coded Hexadecimal Output

| Model | Switch Unit or Connector | Common terminal number | Terminals connected to common | | | |
|-------|--------------------------|------------------------|-------------------------------|---|---|----|
| A7BS | Switch Unit | C | 1 | 2 | 4 | 8 |
| | Connector | 2 | 4 | 5 | 6 | 7 |
| A7PS | Switch Unit | C | 1 | 2 | 4 | 8 |
| | Connector | 3 | 5 | 7 | 9 | 11 |
| Dial | 0 | | | | | |
| | 1 | | • | | | |
| | 2 | | | • | | |
| | 3 | | • | • | | |
| | 4 | | | | • | |
| | 5 | | • | | • | |
| | 6 | | | • | • | |
| | 7 | | • | • | • | |
| | 8 | | | | | • |
| | 9 | | • | | | • |
| | A | | | • | | • |
| | B | | • | • | | • |
| | C | | | | • | • |
| | D | | • | | • | • |
| | E | | | • | • | • |
| | F | | • | • | • | • |

55: Binary-coded Hexadecimal Output with Component-adding Provision

| Model | Switch Unit or Connector | Common terminal number | Terminals connected to common | | | |
|-------|--------------------------|------------------------|-------------------------------|---|---|----|
| A7BS | Switch Unit | C | 1 | 2 | 4 | 8 |
| | Connector | 1, 2 | 4 | 5 | 6 | 7 |
| A7PS | Switch Unit | C | 1 | 2 | 4 | 8 |
| | Connector | 1, 3 | 5 | 7 | 9 | 11 |
| Dial | 0 | | | | | |
| | 1 | | • | | | |
| | 2 | | | • | | |
| | 3 | | • | • | | |
| | 4 | | | | • | |
| | 5 | | • | | • | |
| | 6 | | | • | • | |
| | 7 | | • | • | • | |
| | 8 | | | | | • |
| | 9 | | • | | | • |
| | A | | | • | | • |
| | B | | • | • | | • |
| | C | | | | • | • |
| | D | | • | | • | • |
| | E | | | • | • | • |
| | F | | • | • | • | • |

Dimensions

Note: All units are in millimeters unless otherwise indicated.

■ Push-operated Switches

A7DP-206(-1)
PCB Terminals,
Pen-push Model

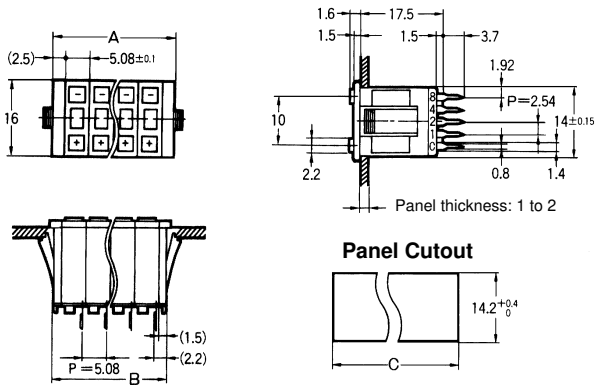

Note: Common terminal C is at the bottom when the Switch Unit is viewed from the front.

| Number of Switches (n) | A (n x 5.1 + 5) | B (n x 5.1 + 3) | C |
|------------------------|--------------------|--------------------|---------|
| 1 | 10.1 mm | 8.1 mm | 8.4 mm |
| 2 | 15.2 mm | 13.2 mm | 13.5 mm |
| 3 | 20.3 mm | 18.3 mm | 18.6 mm |
| 4 | 25.4 mm | 23.4 mm | 23.7 mm |
| 5 | 30.5 mm | 28.5 mm | 28.8 mm |
| 6 | 35.5 mm | 33.5 mm | 33.9 mm |
| 7 | 40.6 mm | 38.6 mm | 39.0 mm |
| 8 | 45.7 mm | 43.7 mm | 44.1 mm |
| 9 | 50.8 mm | 48.8 mm | 49.2 mm |
| 10 | 55.9 mm | 53.9 mm | 54.3 mm |

Note: 1. The dimensions above include both End Caps, and will increase 5.08 mm for each Spacer inserted.
2. Unless otherwise specified, a tolerance of ± 0.4 mm applies to all dimensions. The tolerance for multiple connection is $\pm(\text{number of units} \times 0.4)$ mm.

A7D-106(-1)
PCB Terminals

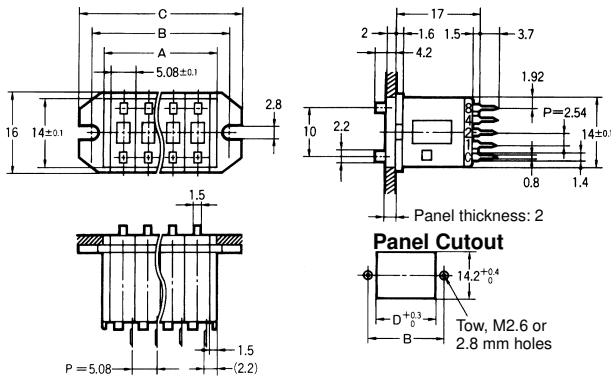
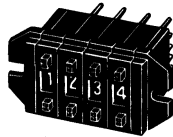

Note: Common terminal C is at the bottom when the Switch Unit is viewed from the front.

| Number of Switches (n) | A (n x 5.1 + 3) | B (n x 5.1 + 8.3) | C (n x 5.1 + 13.3) | D |
|------------------------|--------------------|----------------------|-----------------------|---------|
| 1 | 8.1 mm | 13.4 mm | 18.4 mm | 8.4 mm |
| 2 | 13.2 mm | 18.5 mm | 23.5 mm | 13.5 mm |
| 3 | 18.3 mm | 23.6 mm | 28.6 mm | 18.6 mm |
| 4 | 23.4 mm | 28.7 mm | 33.7 mm | 23.7 mm |
| 5 | 28.5 mm | 33.8 mm | 38.8 mm | 28.8 mm |
| 6 | 33.5 mm | 38.9 mm | 43.9 mm | 33.9 mm |
| 7 | 38.6 mm | 44.0 mm | 49.0 mm | 39.0 mm |
| 8 | 43.7 mm | 49.1 mm | 54.1 mm | 44.1 mm |
| 9 | 48.8 mm | 54.2 mm | 59.2 mm | 49.2 mm |
| 10 | 53.9 mm | 59.3 mm | 64.3 mm | 54.3 mm |

Note: 1. The dimensions above include both End Caps, and will increase 5.08 mm for each Spacer inserted.
2. Unless otherwise specified, a tolerance of ± 0.4 mm applies to all dimensions. The tolerance for multiple connection is $\pm(\text{number of units} \times 0.4)$ mm.

**A7D-206(-1)
PCB Terminals**

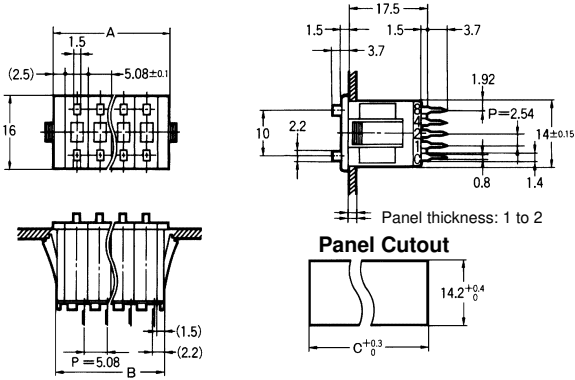

Note: Common terminal C is at the bottom when the Switch Unit is viewed from the front.

| Number of Switches (n) | A (n x 5.1 + 5) | B (n x 5.1 + 3) | C (n x 5.1 + 3.3) |
|------------------------|--------------------|--------------------|----------------------|
| 1 | 10.1 mm | 8.1 mm | 8.4 mm |
| 2 | 15.2 mm | 13.2 mm | 13.5 mm |
| 3 | 20.3 mm | 18.3 mm | 18.6 mm |
| 4 | 25.4 mm | 23.4 mm | 23.7 mm |
| 5 | 30.5 mm | 28.5 mm | 28.8 mm |
| 6 | 35.5 mm | 33.5 mm | 33.9 mm |
| 7 | 40.6 mm | 38.6 mm | 39.0 mm |
| 8 | 45.7 mm | 43.7 mm | 44.1 mm |
| 9 | 50.8 mm | 48.8 mm | 49.2 mm |
| 10 | 55.9 mm | 53.9 mm | 54.3 mm |

Note: 1. The dimensions above include both End Caps, and will increase 5.08 mm for each Spacer inserted.
2. Unless otherwise specified, a tolerance of ±0.4 mm applies to all dimensions.
The tolerance for multiple connection is ±(number of units x 0.4) mm.

A7CN-106-1

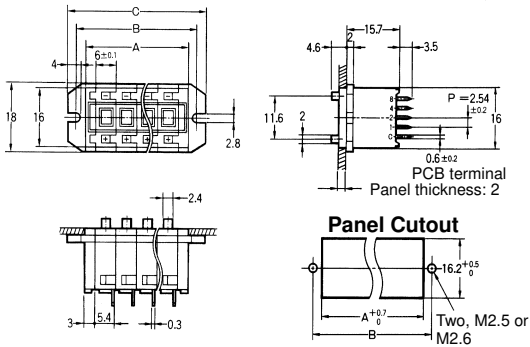
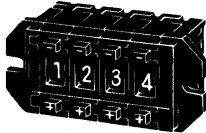

Note: Common terminal C is at the bottom when the Switch Unit is viewed from the front.

| Number of Switches (n) | A (n x 6 + 6) | B (n x 6 + 11) | C (n x 6 + 16) |
|------------------------|------------------|-------------------|-------------------|
| 1 | 12 mm | 17 mm | 22 mm |
| 2 | 18 mm | 23 mm | 28 mm |
| 3 | 24 mm | 29 mm | 34 mm |
| 4 | 30 mm | 35 mm | 40 mm |
| 5 | 36 mm | 41 mm | 46 mm |
| 6 | 42 mm | 47 mm | 52 mm |
| 7 | 48 mm | 53 mm | 58 mm |
| 8 | 54 mm | 59 mm | 64 mm |
| 9 | 60 mm | 65 mm | 70 mm |
| 10 | 66 mm | 71 mm | 76 mm |

Note: 1. The dimensions above include both End Caps, and will increase 6 mm for each Spacer inserted.
2. Unless otherwise specified, a tolerance of ±0.4 mm applies to all dimensions.
The tolerance for multiple connection is ±(number of units x 0.4) mm.

A7CN-206(-1)

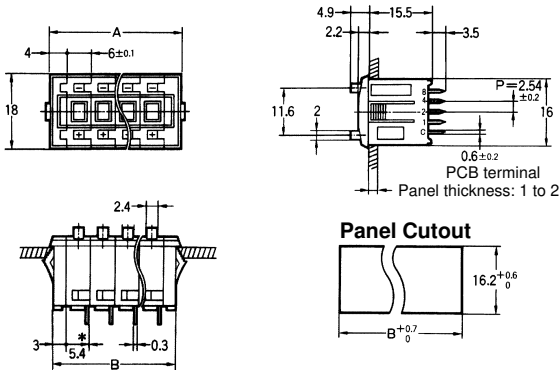
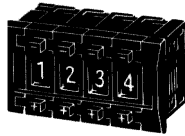

Note: Common terminal C is at the bottom when the Switch Unit is viewed from the front.

| Number of Switches (n) | A (n x 6 + 8) | B (n x 6 + 6) |
|------------------------|---------------|---------------|
| 1 | 14 mm | 12 mm |
| 2 | 20 mm | 18 mm |
| 3 | 26 mm | 24 mm |
| 4 | 32 mm | 30 mm |
| 5 | 38 mm | 36 mm |
| 6 | 44 mm | 42 mm |
| 7 | 50 mm | 48 mm |
| 8 | 56 mm | 54 mm |
| 9 | 62 mm | 60 mm |
| 10 | 68 mm | 66 mm |

Note: 1. The dimensions above include both End Caps, and will increase 6 mm for each Spacer inserted.
 2. Unless otherwise specified, a tolerance of ± 0.4 mm applies to all dimensions.
 The tolerance for multiple connection is $\pm(\text{number of units} \times 0.4)$ mm.

A7CN-L206(-1)

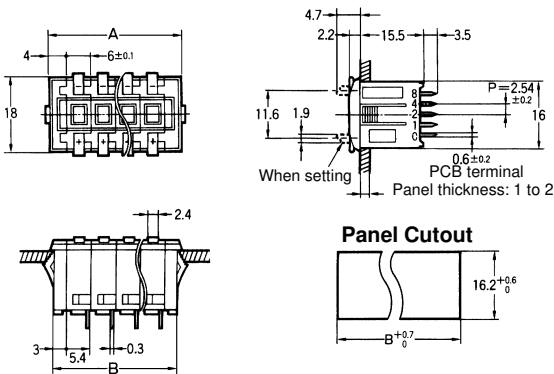
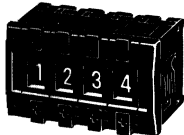

Note: Common terminal C is at the bottom when the Switch Unit is viewed from the front.

| Number of Switches (n) | A (n x 6 + 8) | B (n x 6 + 6) |
|------------------------|---------------|---------------|
| 1 | 14 mm | 12 mm |
| 2 | 20 mm | 18 mm |
| 3 | 26 mm | 24 mm |
| 4 | 32 mm | 30 mm |
| 5 | 38 mm | 36 mm |
| 6 | 44 mm | 42 mm |
| 7 | 50 mm | 48 mm |
| 8 | 56 mm | 54 mm |
| 9 | 62 mm | 60 mm |
| 10 | 68 mm | 66 mm |

Note: 1. The dimensions above include both End Caps, and will increase 6 mm for each Spacer inserted.
 2. Unless otherwise specified, a tolerance of ± 0.4 mm applies to all dimensions.
 The tolerance for multiple connection is $\pm(\text{number of units} \times 0.4)$ mm.

**A7BL-206(-1)
A7BL-207(-1)
Solder Terminals,
Locking Models**

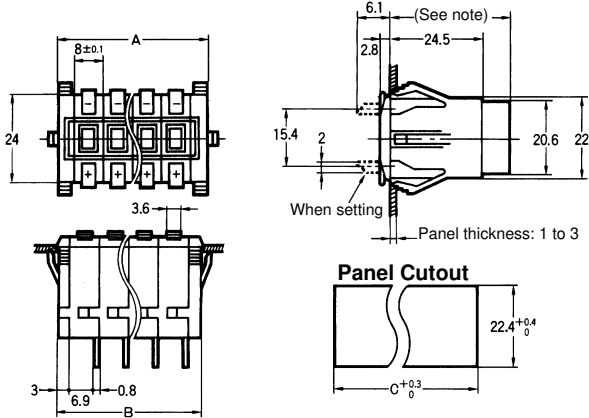
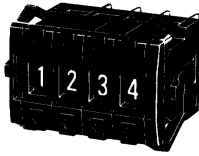

Note: If the output code is 06, the dimension is 32.5; if the output code is 07, the dimension is 43.5.

| Number of Switches (n) | A (n x 8 + 8) | B (n x 8 + 6) | C |
|------------------------|------------------|------------------|---------|
| 1 | 16 mm | 14 mm | 14.4 mm |
| 2 | 24 mm | 22 mm | 22.4 mm |
| 3 | 32 mm | 30 mm | 30.4 mm |
| 4 | 40 mm | 38 mm | 38.4 mm |
| 5 | 48 mm | 46 mm | 46.8 mm |
| 6 | 56 mm | 54 mm | 54.8 mm |
| 7 | 64 mm | 62 mm | 62.8 mm |
| 8 | 72 mm | 70 mm | 70.8 mm |
| 9 | 80 mm | 78 mm | 78.8 mm |
| 10 | 88 mm | 86 mm | 86.8 mm |

Note: 1. The dimensions above include both End Caps, and will increase 8 mm for each Spacer inserted.
2. Unless otherwise specified, a tolerance of ± 0.4 mm applies to all dimensions. The tolerance for multiple connection is $\pm(\text{number of units} \times 0.4)$ mm.

**A7BS-200(-1)
A7BS-200(-1)
Solder Terminals**

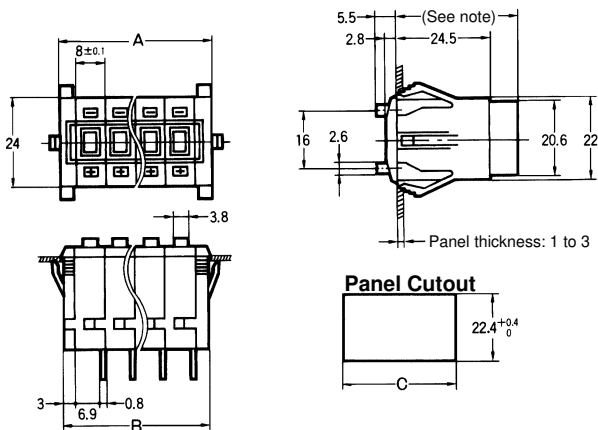
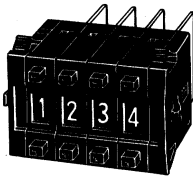

Note: If the output code is 06 or 54, the dimension is 32.5; if the output code is 07 or 55, the dimension is 43.5.

| Number of Switches (n) | A (n x 8 + 8) | B (n x 8 + 6) | C |
|------------------------|------------------|------------------|---------|
| 1 | 16 mm | 14 mm | 14.4 mm |
| 2 | 24 mm | 22 mm | 22.4 mm |
| 3 | 32 mm | 30 mm | 30.4 mm |
| 4 | 40 mm | 38 mm | 38.4 mm |
| 5 | 48 mm | 46 mm | 46.8 mm |
| 6 | 56 mm | 54 mm | 54.8 mm |
| 7 | 64 mm | 62 mm | 62.8 mm |
| 8 | 72 mm | 70 mm | 70.8 mm |
| 9 | 80 mm | 78 mm | 78.8 mm |
| 10 | 88 mm | 86 mm | 86.8 mm |

Note: 1. The dimensions above include both End Caps, and will increase 8 mm for each Spacer inserted.
2. Unless otherwise specified, a tolerance of ± 0.4 mm applies to all dimensions. The tolerance for multiple connection is $\pm(\text{number of units} \times 0.4)$ mm.

A7PS-2□□(-1)
A7PH-2□□(-1)
Solder Terminals

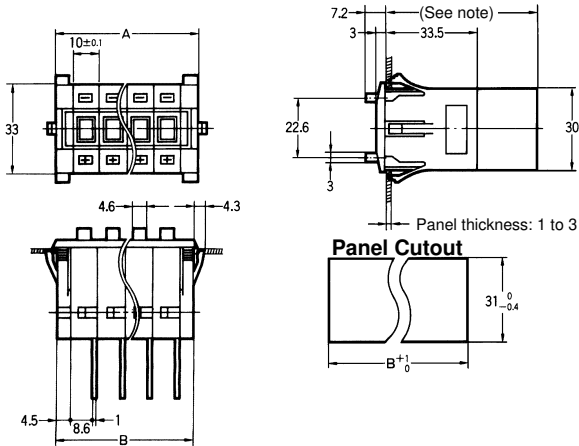
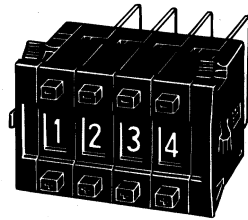

Note: If the output code is 03, 06 or 54, the dimension is 43; if the output code is 07, 19 or 55, the dimension is 55.

| Number of Switches (n) | A (n x 10 + 12) | B (n x 10 + 9) |
|------------------------|-----------------|----------------|
| 1 | 22 mm | 19 mm |
| 2 | 32 mm | 29 mm |
| 3 | 42 mm | 39 mm |
| 4 | 52 mm | 49 mm |
| 5 | 62 mm | 59 mm |
| 6 | 72 mm | 69 mm |
| 7 | 82 mm | 79 mm |
| 8 | 92 mm | 89 mm |
| 9 | 102 mm | 99 mm |
| 10 | 112 mm | 109 mm |

Note: 1. The dimensions above include both End Caps, and will increase 10 mm for each Spacer inserted.
2. Unless otherwise specified, a tolerance of ±0.4 mm applies to all dimensions. The tolerance for multiple connection is ±(number of units x 0.4) mm.

Thumbwheel-operated Switches

A7MD-106-P-09
A7MD-106-P-09-D
PCB Terminals

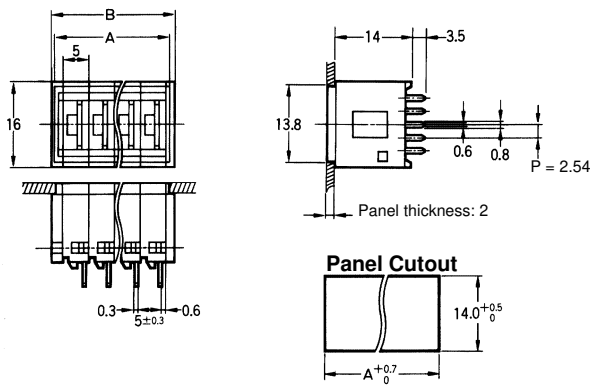

| Number of Switches (n) | A (5n + 3) | B (5n + 5) |
|------------------------|------------|------------|
| 1 | 8 mm | 10 mm |
| 2 | 13 mm | 15 mm |
| 3 | 18 mm | 20 mm |
| 4 | 23 mm | 25 mm |
| 5 | 28 mm | 30 mm |
| 6 | 33 mm | 35 mm |
| 7 | 38 mm | 40 mm |
| 8 | 43 mm | 45 mm |
| 9 | 48 mm | 50 mm |
| 10 | 53 mm | 55 mm |

Note: 1. The dimensions above include both End Caps, and will increase 6 mm for each Spacer inserted.
2. Unless otherwise specified, a tolerance of ±0.4 mm applies to all dimensions. The tolerance for multiple connection is ±(number of units x 0.4) mm.

A7MA-1 Solder Terminals

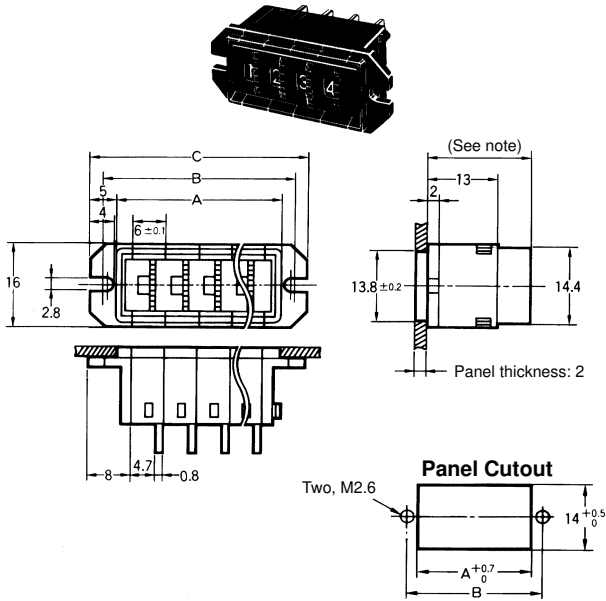

Note: If the output code is 06, the dimension is 19; if the output code is 07, the dimension is 31.

| Number of Switches (n) | A (6n + 6) | B (6n + 11) | C (6n + 16) |
|------------------------|------------|-------------|-------------|
| 1 | 12 mm | 17 mm | 22 mm |
| 2 | 18 mm | 23 mm | 28 mm |
| 3 | 24 mm | 29 mm | 34 mm |
| 4 | 30 mm | 35 mm | 40 mm |
| 5 | 36 mm | 41 mm | 46 mm |
| 6 | 42 mm | 47 mm | 52 mm |
| 7 | 48 mm | 53 mm | 58 mm |
| 8 | 54 mm | 59 mm | 64 mm |
| 9 | 60 mm | 65 mm | 70 mm |
| 10 | 66 mm | 71 mm | 76 mm |

Note: 1. The dimensions above include both End Caps, and will increase 6 mm for each Spacer inserted.
 2. Unless otherwise specified, a tolerance of ±0.4 mm applies to all dimensions. The tolerance for multiple connection is ±(number of units x 0.4) mm.

A7MA-1-P2 PCB Terminals

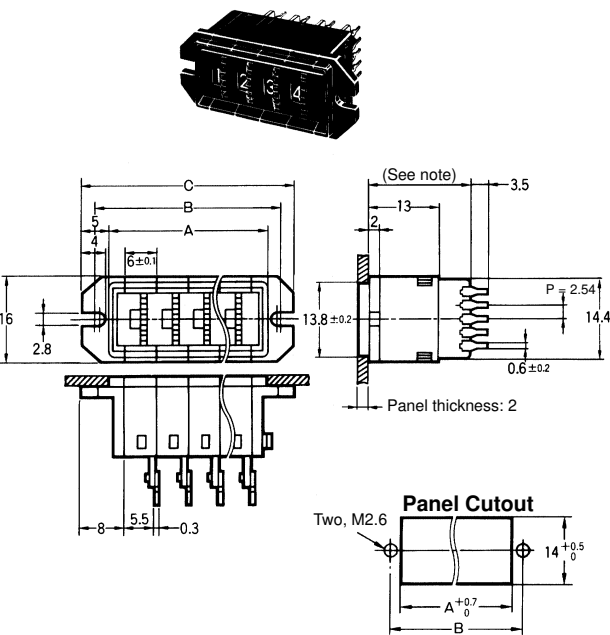

Note: If the output code is 06, the dimension is 19; if the output code is 07, the dimension is 31.

**A7MA-2□□(-1)
Solder Terminals**

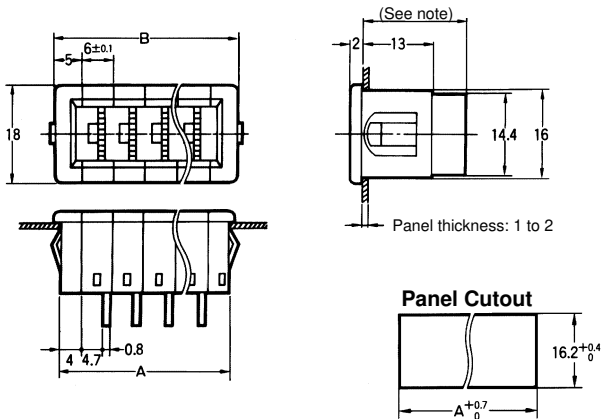
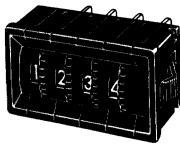

Note: If the output code is 06, the dimension is 19; if the output code is 07, the dimension is 31.

| Number of Switches (n) | A (6n + 8) | B (6n + 10) |
|------------------------|---------------|----------------|
| 1 | 14 mm | 16 mm |
| 2 | 20 mm | 22 mm |
| 3 | 26 mm | 28 mm |
| 4 | 32 mm | 34 mm |
| 5 | 38 mm | 40 mm |
| 6 | 44 mm | 46 mm |
| 7 | 50 mm | 52 mm |
| 8 | 56 mm | 58 mm |
| 9 | 62 mm | 64 mm |
| 10 | 68 mm | 70 mm |

Note: 1. The dimensions above include both End Caps, and will increase 6 mm for each Spacer inserted.
2. Unless otherwise specified, a tolerance of ±0.4 mm applies to all dimensions. The tolerance for multiple connection is ±(number of units x 0.4) mm.

**A7MA-2□□-P2(-1)
PCB Terminals**

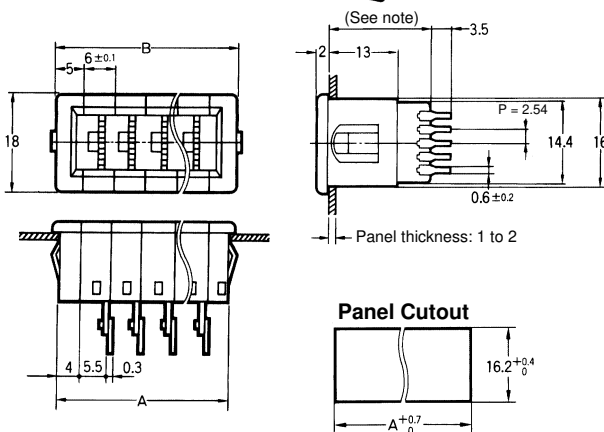
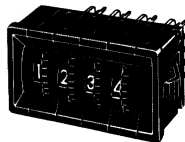

Note: If the output code is 06, the dimension is 19; if the output code is 07, the dimension is 31.

| Number of Switches (n) | A (6n + 8) | B (6n + 10) |
|------------------------|---------------|----------------|
| 1 | 14 mm | 16 mm |
| 2 | 20 mm | 22 mm |
| 3 | 26 mm | 28 mm |
| 4 | 32 mm | 34 mm |
| 5 | 38 mm | 40 mm |
| 6 | 44 mm | 46 mm |
| 7 | 50 mm | 52 mm |
| 8 | 56 mm | 58 mm |
| 9 | 62 mm | 64 mm |
| 10 | 68 mm | 70 mm |

Note: 1. The dimensions above include both End Caps, and will increase 6 mm for each Spacer inserted.
2. Unless otherwise specified, a tolerance of ±0.4 mm applies to all dimensions. The tolerance for multiple connection is ±(number of units x 0.4) mm.

A7SS-1 Solder Terminals

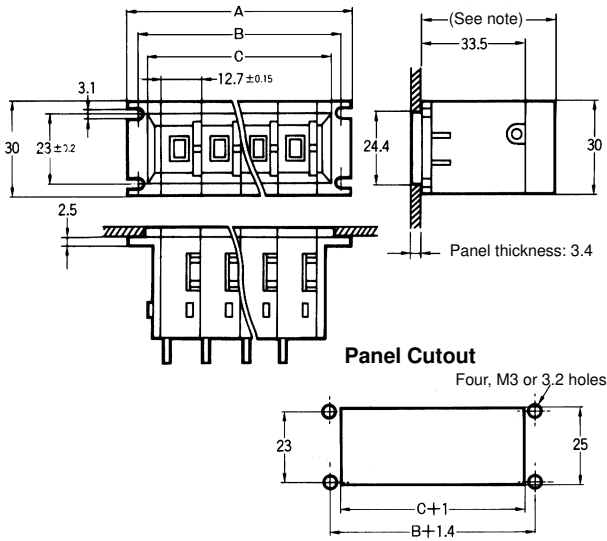
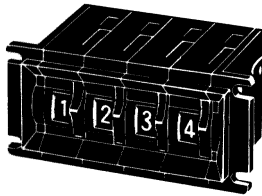

Note: If the output code is 03 or 06, the dimension is 43; if the output code is 07, the dimension is 55.

| Number of Switches (n) | A (12.7n + 22) | B (12.7n + 14.8) | C (12.7n + 10) |
|------------------------|-------------------|---------------------|-------------------|
| 1 | 34.7 mm | 27.5 mm | 22.7 mm |
| 2 | 47.4 mm | 40.2 mm | 35.4 mm |
| 3 | 60.1 mm | 52.9 mm | 48.1 mm |
| 4 | 72.8 mm | 65.6 mm | 60.8 mm |
| 5 | 85.5 mm | 78.3 mm | 73.5 mm |
| 6 | 98.2 mm | 91.0 mm | 86.2 mm |
| 7 | 110.9 mm | 103.7 mm | 98.9 mm |
| 8 | 123.6 mm | 116.4 mm | 111.6 mm |
| 9 | 136.3 mm | 129.1 mm | 124.3 mm |
| 10 | 149.0 mm | 141.8 mm | 137.0 mm |

Note: 1. The dimensions above include both End Caps, and will increase 12.7 mm for each additional Switch inserted (6.35-mm wide Spacers are also available).
 2. Unless otherwise specified, a tolerance of ± 0.4 mm applies to all dimensions. The tolerance for multiple connection is $\pm(\text{number of units} \times 0.4)$ mm.

A7AS-2 Solder terminals

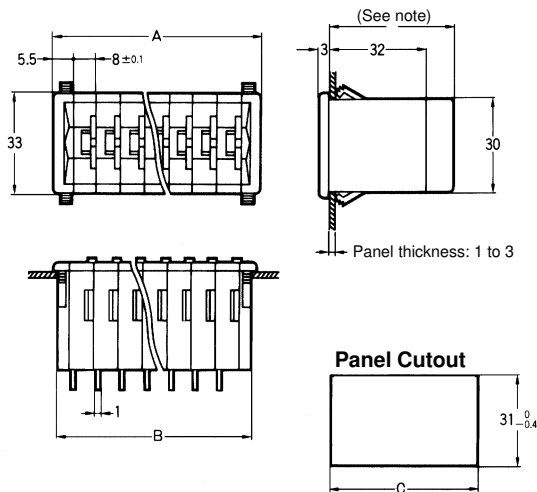
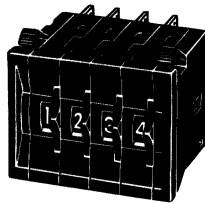

Note: If the output code is 03 or 06, the dimension is 41.5; if the output code is 07 or 19, the dimension is 55.

| Number of Switches (n) | A (8n + 11) | B (8n + 8) | C (B + 1) |
|------------------------|----------------|---------------|--------------|
| 1 | 19 mm | 16 mm | 17 mm |
| 2 | 27 mm | 24 mm | 25 mm |
| 3 | 35 mm | 32 mm | 33 mm |
| 4 | 43 mm | 40 mm | 41 mm |
| 5 | 51 mm | 48 mm | 49 mm |
| 6 | 59 mm | 56 mm | 57 mm |
| 7 | 67 mm | 64 mm | 65 mm |
| 8 | 75 mm | 72 mm | 73 mm |
| 9 | 83 mm | 80 mm | 81 mm |
| 10 | 91 mm | 88 mm | 89 mm |

Note: 1. The dimensions above include both End Caps, and will increase 8 mm for each additional Switch inserted.
 2. Unless otherwise specified, a tolerance of ± 0.4 mm applies to all dimensions. The tolerance for multiple connection is $\pm(\text{number of units} \times 0.4)$ mm.

■ Accessories (Order Separately)

End Caps for Push-operated Switches

A7D-1M(-1) Screw Mounting (Back Mounting)

Left Side

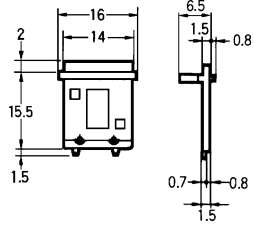

Right Side

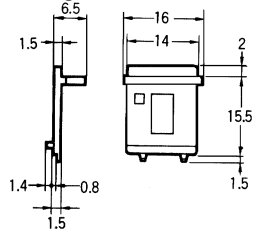

A7D-2M(-1) Snap-in Mounting (Front Mounting)

Left Side

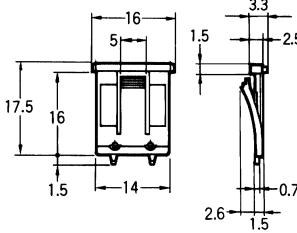

Right Side

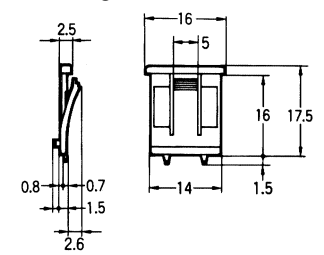

A7CN-1M-1 Screw Mounting

Left Side

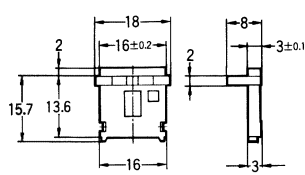

Right Side

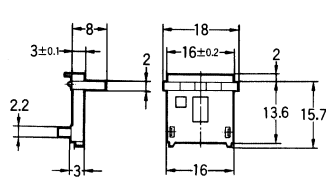

A7CN-2M-1 Snap-in Mounting

Left Side

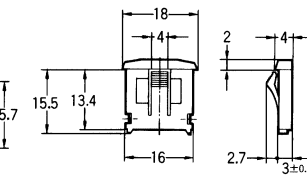

Right Side

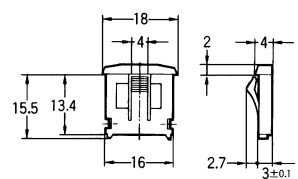

A7B-M(-1) Snap-in Panel Mounting

Left Side

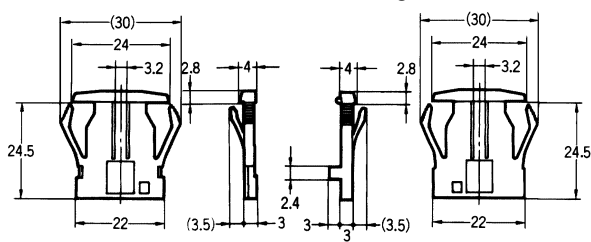

Right Side

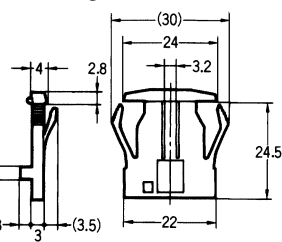

A7P-M(-1) Snap-in Panel Mounting

Left Side

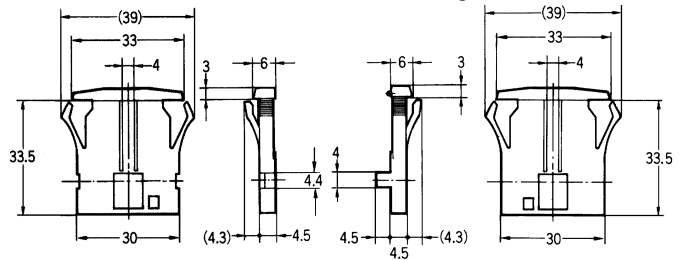

Right Side

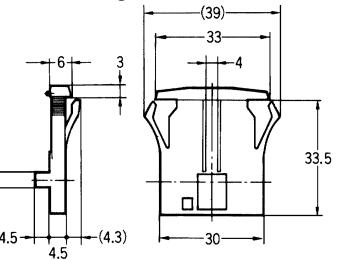

End Caps for Thumbwheel Switches

A7MD-1M PCB Mounting (Side Plate)

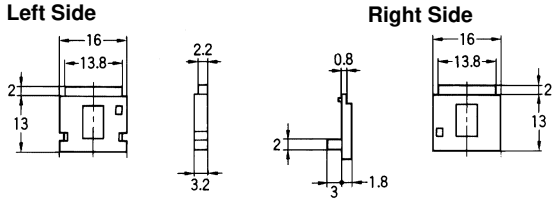

A7M-1M Screw Panel Mounting

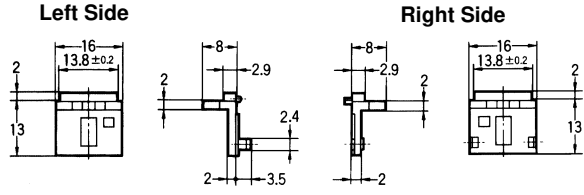

Note: The A7MD cannot be mounted by a screw panel or snap-in panel. Fasten the PC board after mounting the A7MD to the PC board.

A7M-2M(-1) Snap-in Panel Mounting

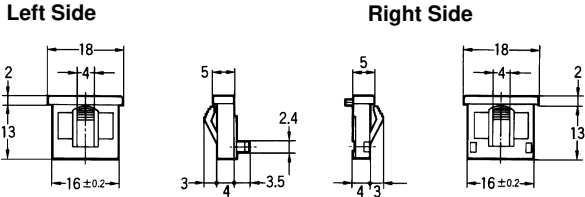

A7SS-M and SRT-M Screw Panel Mounting

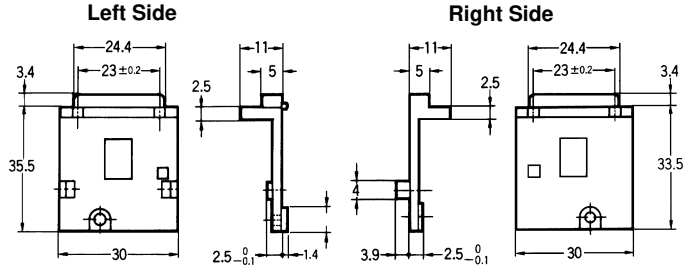

A7AS-M(-1) Snap-in Panel Mounting

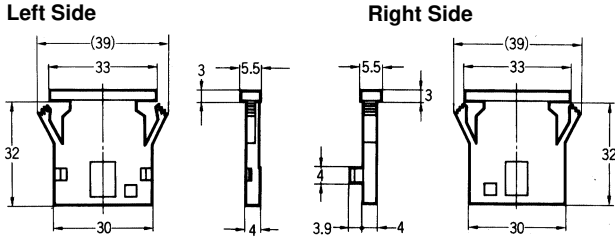

Spacers for Push-operated Switches

A7D-1PA(-1) Screw Mounting (Back Mounting)

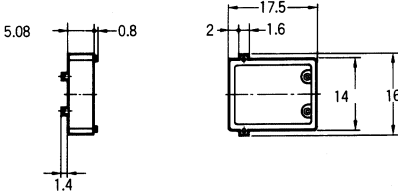

A7D-2PA(-1) Snap-in Mounting (Front Mounting)

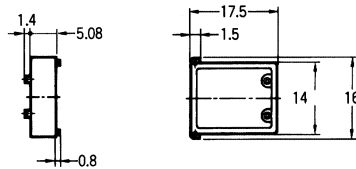

A7CN-1P-1 Screw Panel Mounting Model

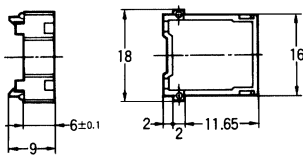

A7CN-2P-1 Snap-in Mounting Model

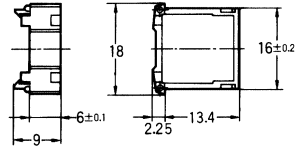

A7B-PA(-1) Snap-in Panel Mounting

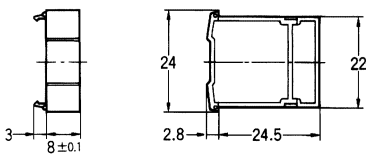

A7P-PA(-1) Snap-in Panel Mounting

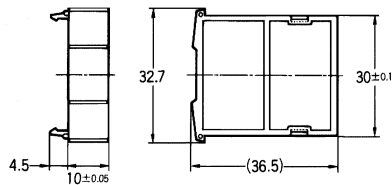

Spacers for Thumbwheel Switches

A7MD-PA PCB Mounting

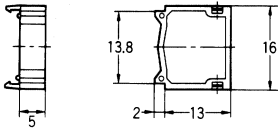

A7M-1PA Screw Panel Mounting

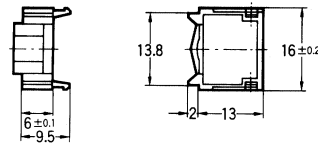

A7M-2PA(-1) Snap-in Panel Mounting

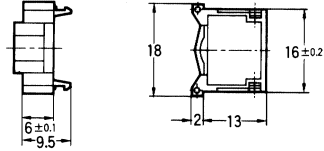

Stamping

When units of time or lengths are required, stamping any of the additional Switches and Spacers above with text or symbols is possible. Designate the desired stamping by symbol to substitute the "A" for the "-PA" on the model numbers according to the table below.

| Symbol | A | B | C | D | E | F | G | H | J | K | L | Q | T | U |
|--------|----------------|-----|-----|---|---|----|----|----|---|----|-----|----------|---|---|
| Stamp | No designation | SEC | MIN | H | g | kg | mm | cm | m | °C | PCS | x 10 SEC | 0 | • |

Stopper Pins (for Only the A7BS-20□-S)

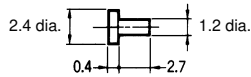

- Note:**
- Two pins constitute one set.
 - The first shipment is free and is attached to the Switch.

Connectors

These devices allow Switches to be quickly removed for maintenance and inspection of connectivity, and quickly re-installed.

A7B-C Solder Terminals

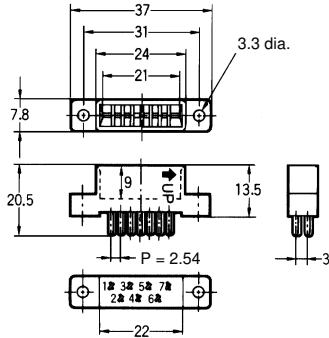

A7B-CP PCB Terminals

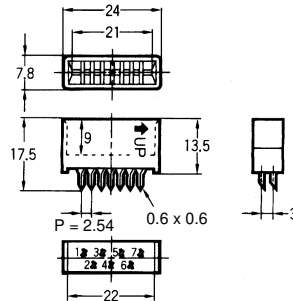

Inserting Connectors

Insert Connectors with the "UP" arrow pointing up.

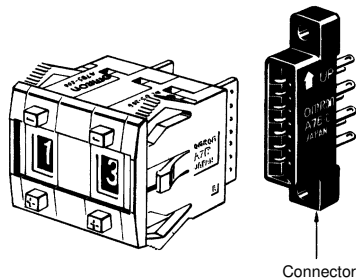

Note: Unless otherwise indicated, dimensional tolerances for dimensions in the models above are ±0.4 mm.

Installation

■ Terminals

Push-operated Switches

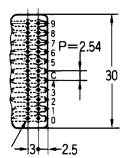
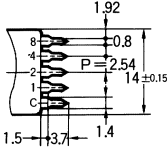
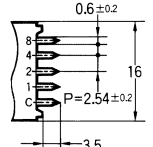
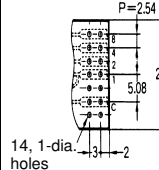
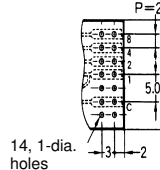
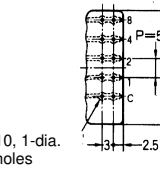
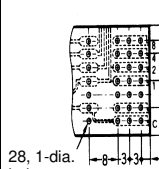
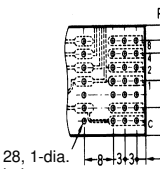
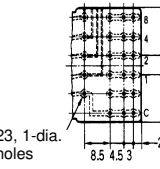
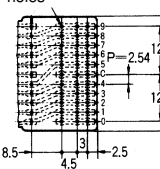
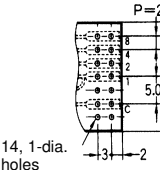
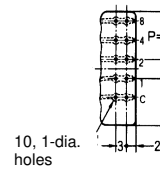
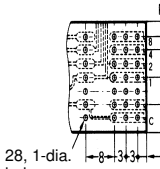
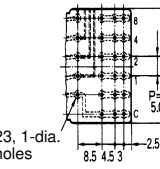
| Output code | A7DP-2/A7D-1 /A7D-2 (PCB terminals) | A7CN-2/A7CN-1 /A7CN-L (PCB terminals) | A7BL (solder terminals) | A7BS/A7BS-20-S (solder terminals) | A7PS/A7PH (solder terminals) |
|-------------|---|---|---|--|---|
| 03 | --- | --- | --- | --- |  <p>22, 1-dia. holes</p> |
| 06 |  |  |  <p>14, 1-dia. holes</p> |  <p>14, 1-dia. holes</p> |  <p>10, 1-dia. holes</p> |
| 07 | --- | --- |  <p>28, 1-dia. holes</p> |  <p>28, 1-dia. holes</p> |  <p>23, 1-dia. holes</p> |
| 19 | --- | --- | --- | --- |  <p>44, 1-dia. holes</p> |
| 54 | --- | --- | --- |  <p>14, 1-dia. holes</p> |  <p>10, 1-dia. holes</p> |
| 55 | --- | --- | --- |  <p>28, 1-dia. holes</p> |  <p>23, 1-dia. holes</p> |

Thumbwheel Switches

| Output code | A7MD (PCB terminals) | A7MA- (solder terminals) | A7MA-P2 (PCB terminals) | A7SS/A7AS (solder terminals) |
|-------------|-------------------------|-----------------------------|----------------------------|---------------------------------|
| 01 | -- | -- | -- | -- |
| 03 | -- | -- | -- | |
| 06 (13) | | | | |
| 07 (36) | -- | | | |
| 08 | -- | -- | -- | -- |
| 19 | -- | -- | -- | |
| 22 | -- | -- | -- | -- |

Switches with Component-adding Provision

To add diodes or resistors to Thumbwheel Switch circuits, use models with terminals that allocate component-adding provisions (e.g., output codes 07, 19, 55, etc.).

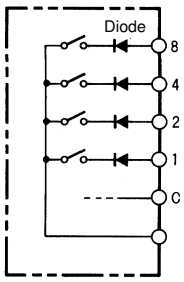
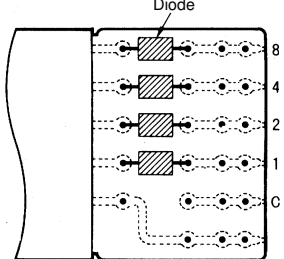
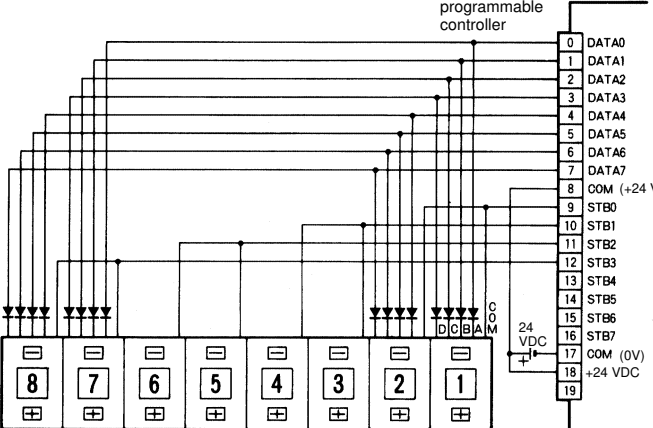
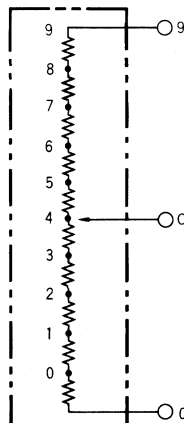
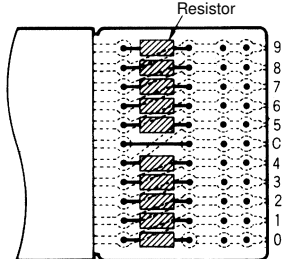
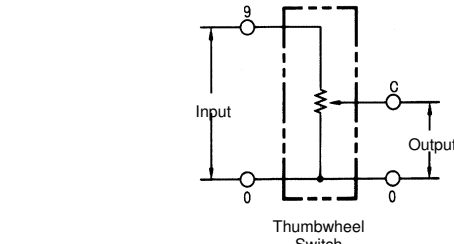
| Examples | Circuit example | Circuit board | Application example |
|--------------------------------------|---|--|--|
| <p>For mounting diodes</p> |  <p>Thumbwheel Switch</p> |  <p>Thumbwheel Switch (e.g., A7PS-207)</p> <p>Note: Use the terminal marked with the asterisk * if the common terminal needs no resistor or diode.</p> | <p>For Programmable Controller inputs (OMRON C500 or C2000H)</p>  <p>Thumbwheel Switch</p> |
| <p>For mounting resistors</p> |  <p>Thumbwheel Switch</p> |  <p>Thumbwheel Switch (e.g., A7PS-219)</p> | <p>As a voltage divider or digital variable resistor</p>  <p>Thumbwheel Switch</p> |

Precautions

Environment

Do not use where gases are generated (ammonia, chlorine, sulfur dioxide).

Although Switches are of nearly dust-proof construction, they are not drip-proof, therefore do not use in areas subject to water or oil exposure and do not operate with wet or oily hands. (The A7MD has a dust-proof construction on contact parts, but consider your installation location carefully. The A7MA is not of dust-proof construction.)

Provide additional dust-proofing measure when using in sand-exposed areas.

Setting Numbers

Locking Type

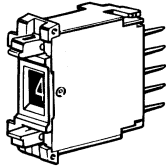

Set with the setting button by raising it.

Return the button to its original position after setting. It is then locked to prevent rotation, and the set numbers will not change accidentally.

Pen-push Type

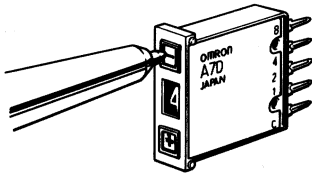

To set, press the setting button with a ball-point pen or other pointed object. However, avoid using pencils or mechanical pencils as broken lead or lead dust may enter and damage the Switch.

Handling

Use alcohol to wipe off dirt and smudges from the molded-plastic cases. Take care to prevent the alcohol from getting inside.

Do not use thinner or other solutions which might damage the plastic.

When connecting Switches, fit the mating parts together.

When separating Switches, use a screwdriver as shown in the figure below; disconnect them by releasing the top and bottom hooks.

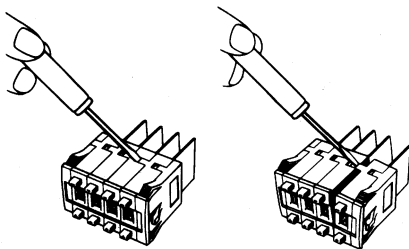

Do not push the (+) and (-) operating push-buttons at the same time with undue force.

Terminals for PCB Models

When using terminals for printed circuit boards, make the terminal insertion holes in the back board (mother board) 1 mm or larger in diameter.

Do not use excessive force in handling terminals for printed circuit boards. In particular, take care to avoid dropping them as the terminals might bend or break.

Reference: Terminals can withstand a force of 0.8 g for 1 minute or more, and survive bending of 20° without breaking after returning to original position.

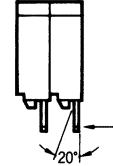

The A7MD accommodates only printed circuit boards. When pulling out the operating surface from the back of the panel, refer to the figures for panel mounting dimensions. However, it cannot be fastened alone to the panel.

Connectors

Insert Connectors while keeping the arrow pointing up (refer to page 31).

Connector insertion load is about 1.5 kg for each A7B-C.

Setting the Stopper (A7BS-20□-S)

With the A7BS-20□-S, any range can be set outside with the Stopper Pin. Insert the Stopper Pin using the following procedure:

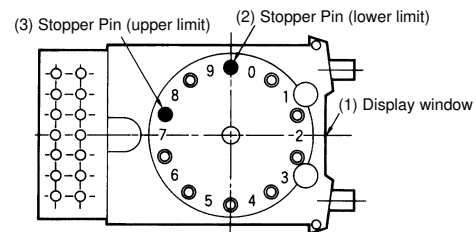

Example: To Display the Range 0 to 7

- Any number within the range of (0 to 7) can be chosen to limit the numbers displayed in the display window. (In this example, 8 and 9 are outside of this range.)
- First, insert the Stopper Pin in the hole in front of the lower limit ("0") for the number to be defined.
- Next, insert the Stopper Pin in the hole past the upper limit ("7") for the number to be defined. (The Stopper Pins then surround the exact range to be defined.)

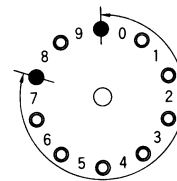

- Confirm that the (+) push-button can no longer be pushed after reaching the upper limit of ("7").

5. Confirm that the (–) push-button can no longer be pushed after reaching the lower limit of ("0"). This completes the setting.

For Stoppers other than those for the A7BS-20-S, refer to pages 5 to 11 of the *Selection Guide* as well as the ordering information on page 15. All manufactured Switches have their ranges factory-set before shipment.

Soldering

Note the following points when soldering printed circuit boards:

Automatic Soldering

After coating with flux foam 1, dip into a soldering tank 2. Thereafter, do not dip to clean. There is no danger of flux penetration in processes 1 and 2, but penetration will occur with dip cleaning, causing contact and rotational defects. Clean the flux as shown in Figure 1, tilting the Switch 45° or more and using a brush to apply the solvent only to the back of the board. It may also be cleaned by dipping only the back of the board into solvent and then using a brush to clean.

Figure 1

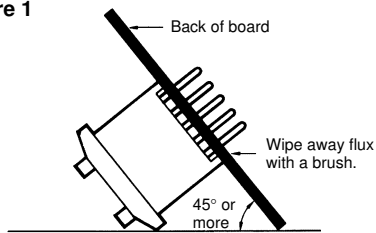

Dip Soldering

Dip into flux solvent 1, and then into a soldering tank 2. The dipping time in process 1 is a maximum of 2 seconds. As shown in Figure 2, avoid flooding the top surface of the printed circuit board with flux. Using a brush to apply flux further reduces the danger of flux penetration. As shown in Figure 2, a brush should be used while tilting the board 45° or more. Flush flux as described above under *Automatic Soldering*.

Figure 2

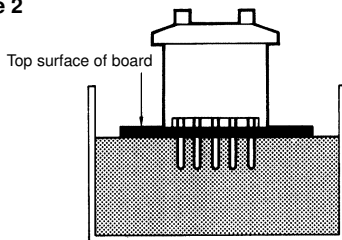

Using a Soldering Iron

Use a 30-W soldering iron at a temperature of 350°C for a maximum of 3 seconds, and flush as described above.