



Chipsmall Limited consists of a professional team with an average of over 10 year of expertise in the distribution of electronic components. Based in Hongkong, we have already established firm and mutual-benefit business relationships with customers from,Europe,America and south Asia,supplying obsolete and hard-to-find components to meet their specific needs.

With the principle of "Quality Parts,Customers Priority,Honest Operation,and Considerate Service",our business mainly focus on the distribution of electronic components. Line cards we deal with include Microchip,ALPS,ROHM,Xilinx,Pulse,ON,Everlight and Freescale. Main products comprise IC,Modules,Potentiometer,IC Socket,Relay,Connector.Our parts cover such applications as commercial,industrial, and automotives areas.

We are looking forward to setting up business relationship with you and hope to provide you with the best service and solution. Let us make a better world for our industry!



## Contact us

Tel: +86-755-8981 8866 Fax: +86-755-8427 6832

Email & Skype: info@chipsmall.com Web: www.chipsmall.com

Address: A1208, Overseas Decoration Building, #122 Zhenhua RD., Futian, Shenzhen, China



LOC		DIST		REVISIONS			
GP	00	REV	DATE	BY	CHK	APPV	
B1	REVISED PER ECO-11-004835		11MAR11	RK	HMR		

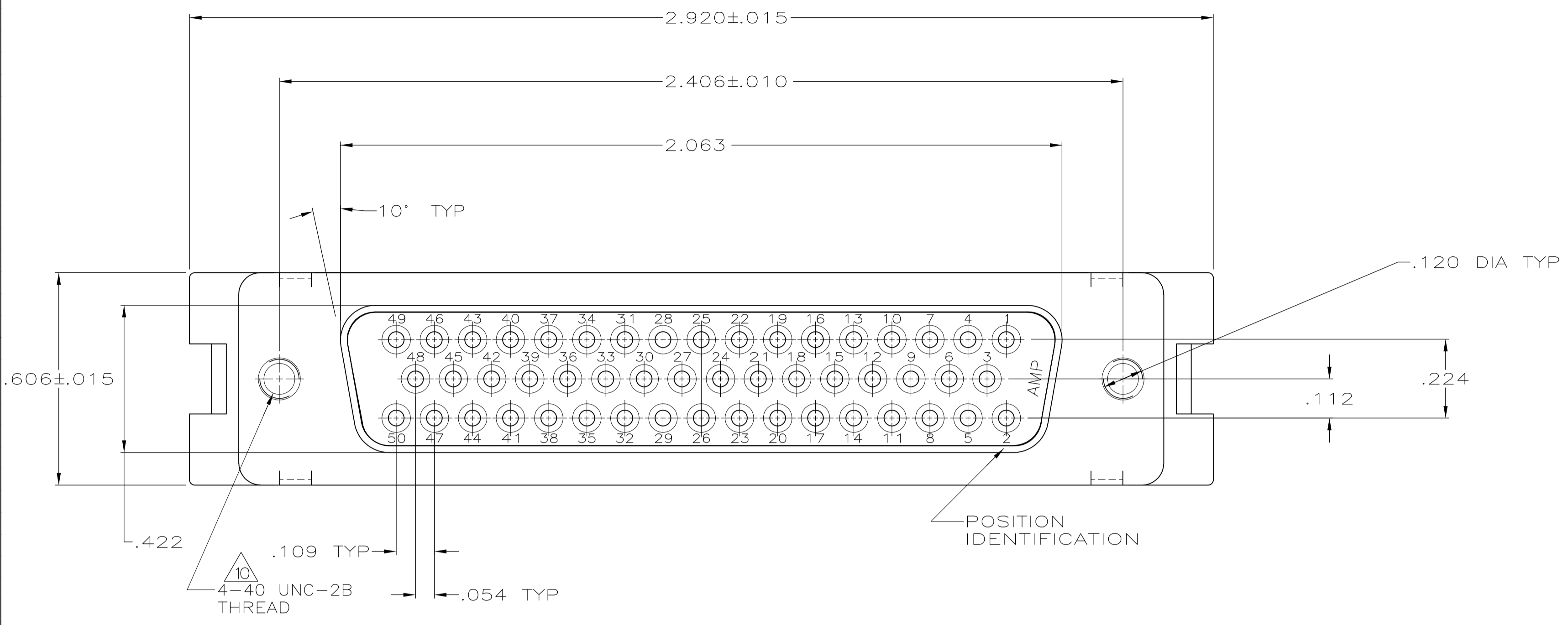

- CONNECTORS COMPLY WITH AMP SPEC 108-40012.
  - CONNECTOR DESIGNED FOR 28 AND 26 AWG STRANDED AND SOLID CONDUCTOR RIBBON CABLE ON .050  $\phi$ .
- △3 DIMENSION APPLIES TO TERMINATED CONNECTOR.  
 △4 MOLDED PARTS:FLAME RETARDANT 94V-0 RATED THERMOPLASTIC; COLOR:BLACK.  
 △5 SHELL: STEEL PER QQ-S-698.  
 △6 CONTACTS: PH BRZ PER QQ-B-750.  
 △7 GOLD PLATING PER MIL-G-45204, TIN PLATING PER MIL-T-10727,NICKEL PLATING PER QQ-N-290.  
 △8 SHELL: BRIGHT TIN PLATED.  
 △9 CONTACTS: PLATED .000030 GOLD IN LOCALIZED GOLD PLATE AREA,.000100 - .000200 MATTE TIN ON TERMINATION END,ALL OVER .000050 NICKEL ON ENTIRE CONTACT.  
 △10 THE MAX SCREW PENETRATION INTO THE CONNECTOR = .312.  
 △11 THREADED INSERTS: ZINC PLATED .000150-.000300 THICK, CLEAR CHROMATE COATED.

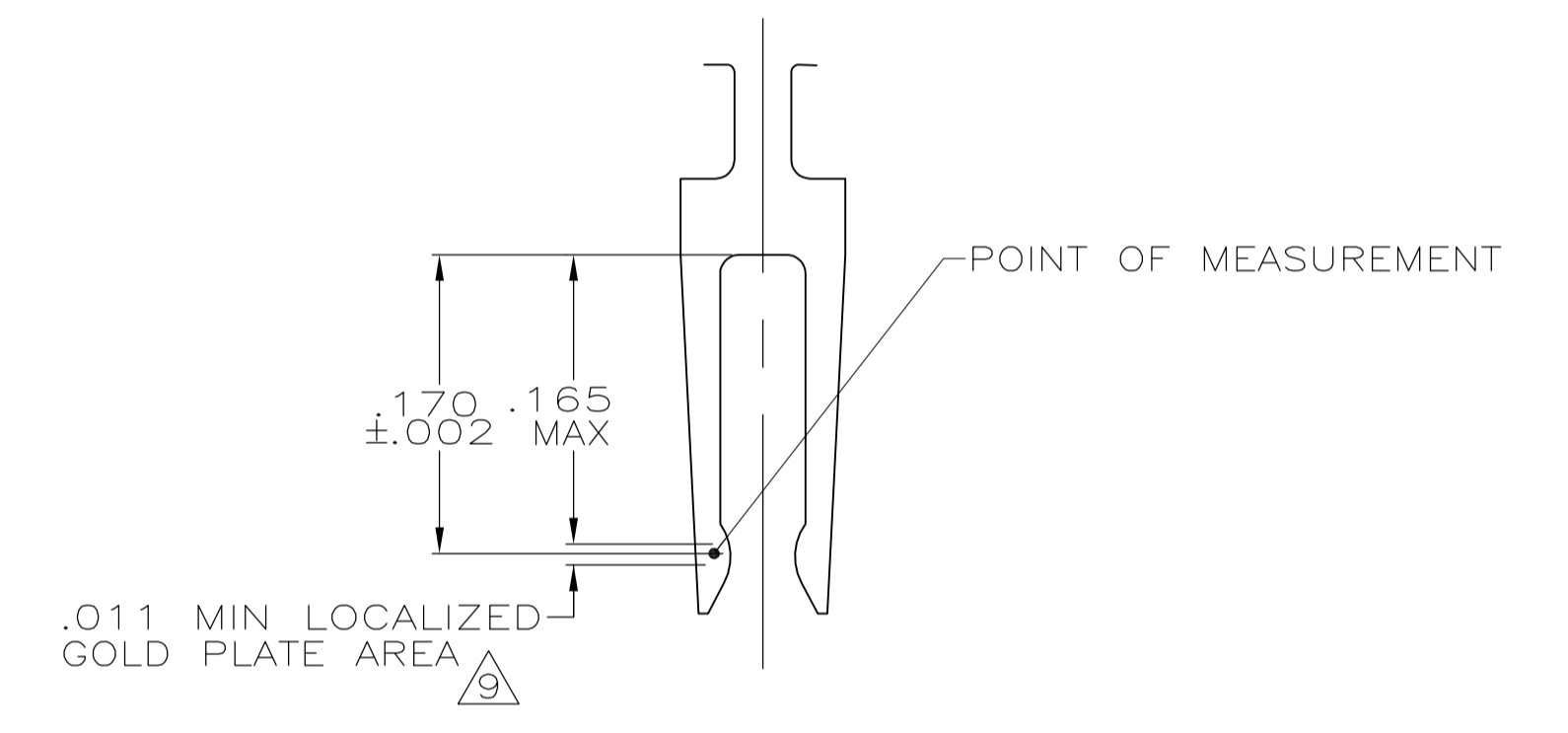
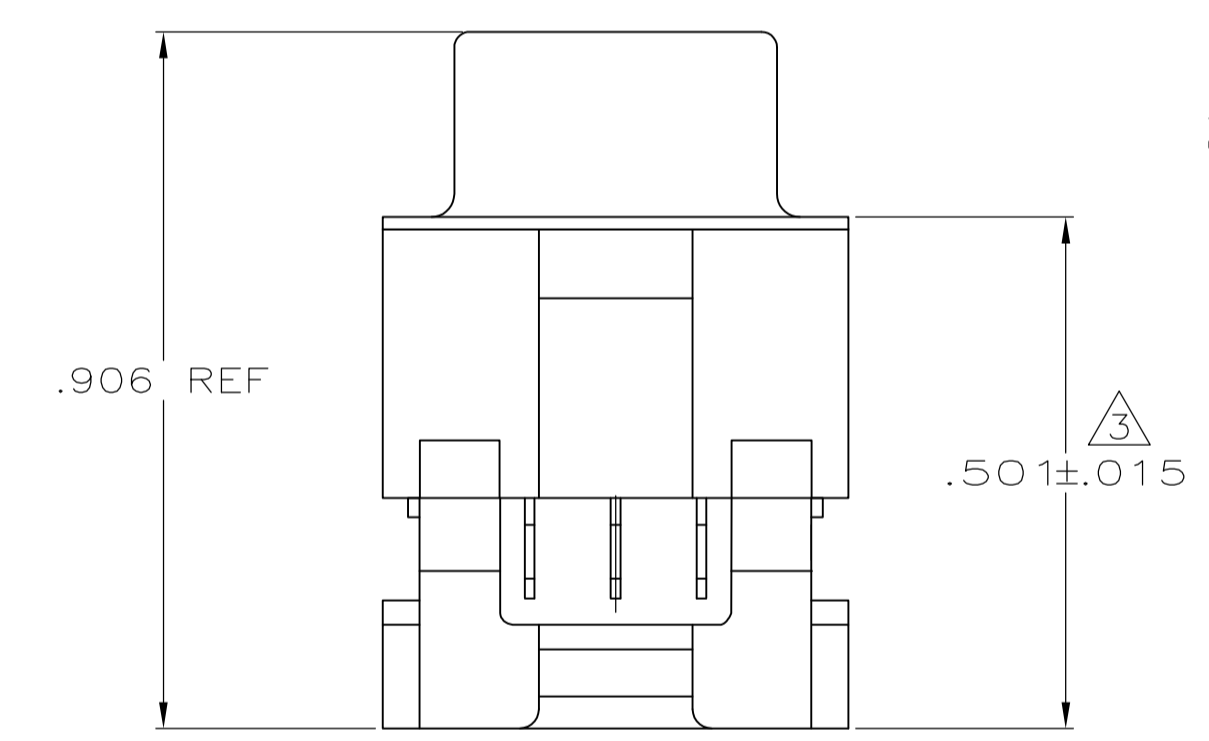
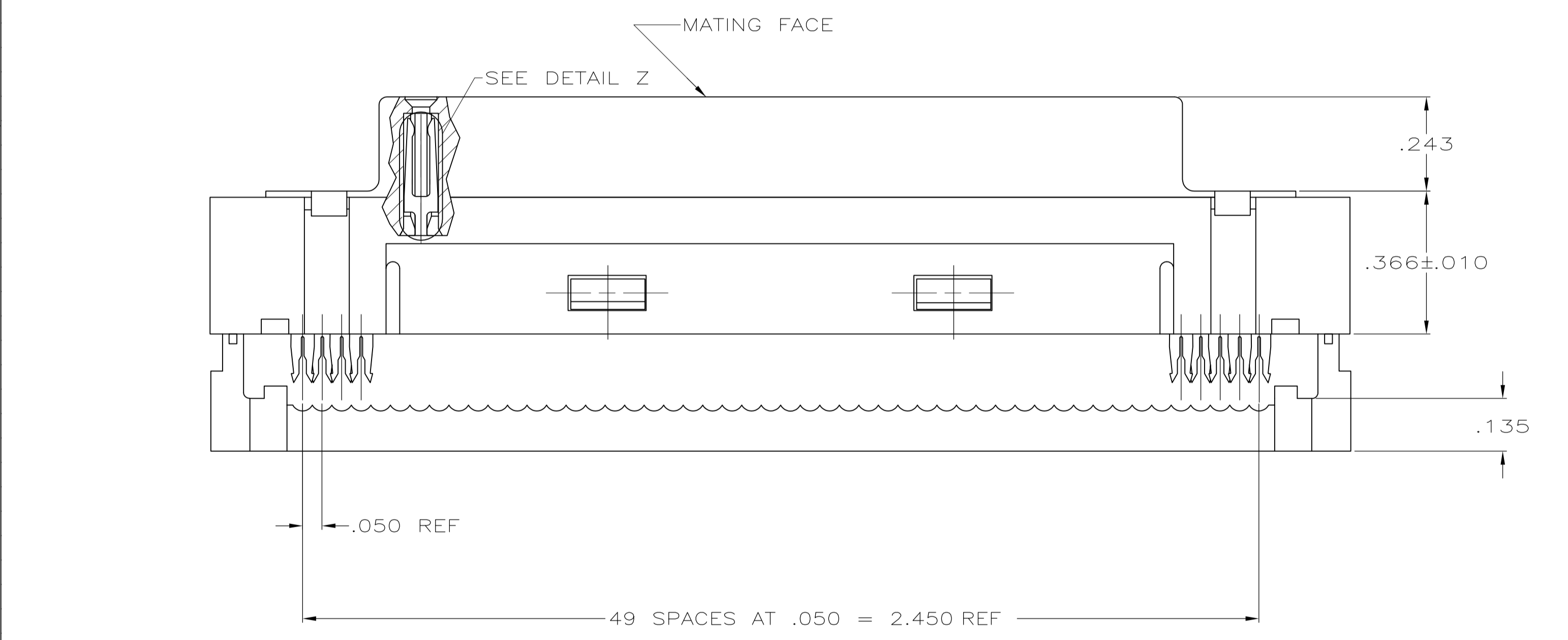

DETAIL Z  
SCALE 10:1  
ROTATED 180° CW

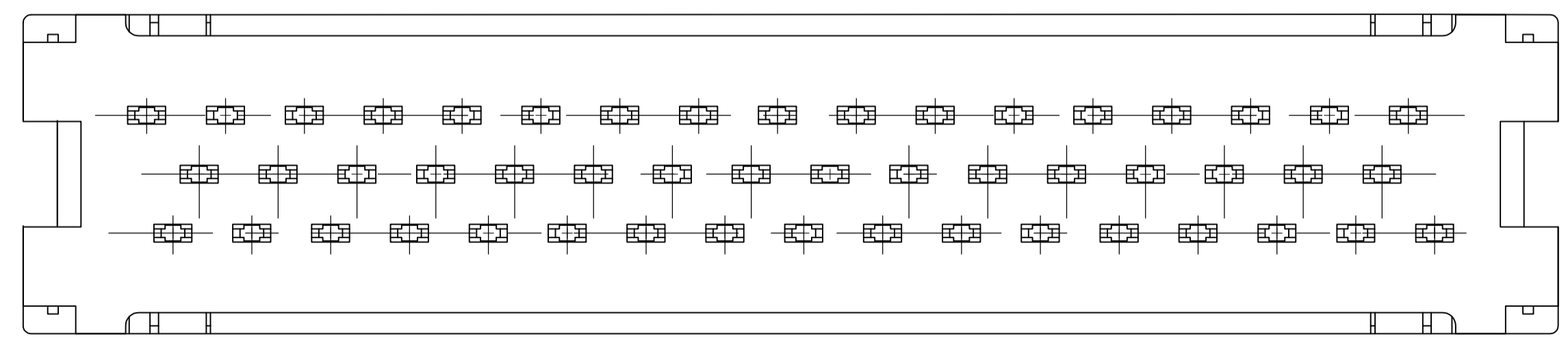

1658606-1  
PART NO

THIS DRAWING IS A CONTROLLED DOCUMENT.		DIN	L. BAUM	6/12/03	TE Connectivity
DIMENSIONS: INCHES		CHK	C. ROHDE	6/12/03	
TOLERANCES UNLESS OTHERWISE SPECIFIED:		APPV	M. WALMSLEY	6/12/03	NAME
0 PLC ± -		PRODUCT SPEC		RECPT ASSY, HDF, FRONT METAL SHELL LEAD-FREE, AMP-LATCH	
1 PLC ± -		APPLICATION SPEC		-	
2 PLC ± -		SIZE	A1	CAGE CODE	00779
3 PLC ± .005		DRAWING NO	1658606		RESTRICTED TO
4 PLC ± -		WEIGHT	-		-
ANGLES ± -		CUSTOMER DRAWING		SCALE	NTS
MATERIAL		SHEET		1	OF 1
FINISH		REV		B1	