



Chipsmall Limited consists of a professional team with an average of over 10 year of expertise in the distribution of electronic components. Based in Hongkong, we have already established firm and mutual-benefit business relationships with customers from,Europe,America and south Asia,supplying obsolete and hard-to-find components to meet their specific needs.

With the principle of “Quality Parts,Customers Priority,Honest Operation,and Considerate Service”,our business mainly focus on the distribution of electronic components. Line cards we deal with include Microchip,ALPS,ROHM,Xilinx,Pulse,ON,Everlight and Freescale. Main products comprise IC,Modules,Potentiometer,IC Socket,Relay,Connector.Our parts cover such applications as commercial,industrial, and automotives areas.

We are looking forward to setting up business relationship with you and hope to provide you with the best service and solution. Let us make a better world for our industry!



Contact us

Tel: +86-755-8981 8866 Fax: +86-755-8427 6832

Email & Skype: info@chipsmall.com Web: www.chipsmall.com

Address: A1208, Overseas Decoration Building, #122 Zhenhua RD., Futian, Shenzhen, China



Wide Input Voltage Range, High-Efficiency, Fault-Tolerant LED Driver

FEATURES AND BENEFITS

- Automotive AEC-Q100 qualified
- Fully integrated 42 V MOSFET for boost converter
- Fully integrated LED current sinks
- Withstands surge input up to 40 V_{IN} for load dump
- Operates down to 3.9 V_{IN} (max) for idle stop
- Drives four strings of LEDs
- Maximum output voltage 40 V
 - Up to 11 white LEDs in series
- Drive current for each string is 100 mA
- Programmable boost switching frequency (200 kHz to 2.15 MHz)
- Synchronized boost switching frequency option (260 kHz to 2.3 MHz)
- Dithering of boost switching frequency to reduce EMI
- Extremely high LED contrast ratio
 - 10,000:1 using PWM dimming alone
 - 100,000:1 when combining PWM and analog dimming

Continued on the next page...

Packages:

20-Pin TSSOP with Exposed Thermal Pad (suffix LP)

28-Pin QFN with Exposed Thermal Pad (suffix ET)

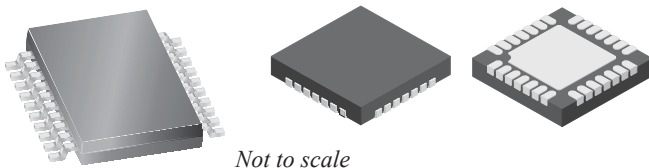

DESCRIPTION

The A8519 is a multi-output LED driver for small-size LCD backlighting. It integrates a current-mode boost converter with internal power switch and four current sinks. The boost converter can drive up to 44 white LEDs, 11 LED per string, at 100 mA. The LED sinks can be paralleled together to achieve higher LED currents up to 400 mA. The A8519 operates from a single power supply from 4.5 to 40 V, which allows the part to withstand load dump conditions encountered in automotive systems.

The A8519 can control LED brightness through a digital (PWM) signal. An LED brightness contrast ratio of 10,000:1 can be achieved using PWM dimming at 100 Hz; a higher ratio of 100,000:1 is possible when using a combination of PWM and analog dimming.

If required, the A8519 can drive an external P-channel MOSFET to disconnect input supply from the system in the event of a fault. The A8519 provides protection against output short, overvoltage, open or shorted diode, open or shorted LED pin, and overtemperature. A cycle-by-cycle current limit protects the internal boost switch against high-current overloads.

Continued on the next page...

APPLICATIONS:

- Automotive infotainment backlighting
- Automotive cluster
- Automotive center stack

Typical Application Diagram

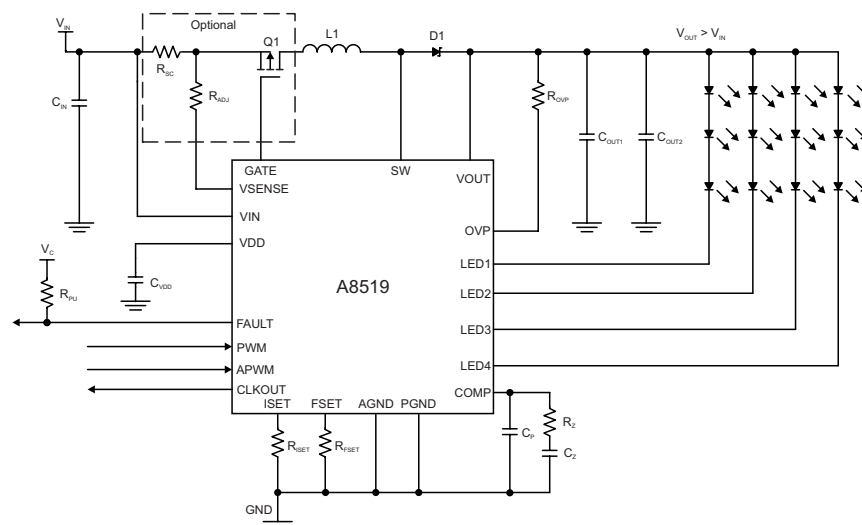

Typical Application Circuit Showing VOUT-to-Ground Short Protection Using Optional P-Channel MOSFET

A8519 and A8519-1

Wide Input Voltage Range, High-Efficiency, Fault-Tolerant LED Driver

FEATURES AND BENEFITS (continued)

- Excellent input voltage transient response at lowest PWM duty cycle
- Gate driver for optional P-channel MOSFET input disconnect switch
- LED current accuracy 0.7%
- LED string current-matching accuracy 0.8%
- Protection against:
 - Shorted boost switch, inductor or output capacitor
 - Shorted FSET or ISET resistor
 - Open or shorted LED pins and LED strings
 - Open boost diode
 - Overtemperature

DESCRIPTION (continued)

The A8519 has a synchronization pin that allows boost switching frequencies to be synchronized in the range of 260 kHz to 2.3 MHz. The high switching frequency allows the converter to operate above the AM radio band. The IC contains a clock output pin that allows other converters to be synchronized to the A8519's boost switching frequency.

The A8519 employs hysteresis control to help regulate the LED current at extremely short PWM on-time. The A8519-1 is identical to the A8519, except that it uses a smaller hysteresis window to reduce output voltage ripple during PWM dimming.

SELECTION GUIDE

Part Number	Operating Ambient Temperature Range T_A (°C)	Hysteresis Window	Package	Packaging [1]	Leadframe Plating
A8519KLPTR-T	-40 to 125	350 mV	20-pin TSSOP with exposed thermal pad	4000 pieces per reel	100% matte tin
A8519KETTR-R	-40 to 125	350 mV	28-pin 5 × 5 mm QFN with exposed thermal pad and sidewall plated	1500 pieces per reel	100% matte tin
A8519KLPTR-T-1	-40 to 125	150 mV	20-pin TSSOP with exposed thermal pad	4000 pieces per reel	100% matte tin
A8519KETTR-R-1	-40 to 125	150 mV	28-pin 5 × 5 mm QFN with exposed thermal pad and sidewall plated	1500 pieces per reel	100% matte tin

¹ Contact Allegro for additional packing options.



ABSOLUTE MAXIMUM RATINGS [2]

Characteristic	Symbol	Notes	Rating	Unit
LEDx Pins	V_{LEDx}	x = 1, 2, 3, or 4	-0.3 to 40	V
OVP Pin	V_{OVP}		-0.3 to 40	V
VIN, VOUT Pins	V_{IN}, V_{OUT}		-0.3 to 40	V
VSENSE, GATE Pins	V_{SENSE}, V_{GATE}		$V_{IN} - 7.4$ to $V_{IN} + 0.4$	V
SW Pin [3]	V_{SW}	Continuous	-0.6 to 42	V
		t < 50 ns	-1 to 48	V
FAULT Pin	V_{FAULT}		-0.3 to 40	V
APWM, PWM, CLKOUT, COMP, FSET, ISET, VDD Pins			-0.3 to 5.5	V
Operating Ambient Temperature	T_A	K temperature range	-40 to 125	°C
Maximum Junction Temperature	$T_{J(max)}$		150	°C
Storage Temperature	T_{stg}		-55 to 150	°C

² Operation at levels beyond the ratings listed in this table may cause permanent damage to the device. The absolute maximum ratings are stress ratings only, and functional operation of the device at these or any other conditions beyond those indicated in the electrical characteristics table is not implied. Exposure to absolute maximum-rated conditions for extended periods may affect device reliability.

³ SW DMOS is self-protecting and will conduct when V_{SW} exceeds 48 V.

A8519 and A8519-1

Wide Input Voltage Range, High-Efficiency, Fault-Tolerant LED Driver

THERMAL CHARACTERISTICS: May require derating at maximum conditions; see application information.

Characteristic	Symbol	Test Conditions [1]	Value	Unit
Package Thermal Resistance	$R_{\theta JA}$	LP Package on 2-layer 3 in ² PCB	40	°C/W
		ET Package on 2-layer 3 in ² PCB	Contact factory	°C/W
		LP Package on 4-layer PCB Based on JEDEC Standards	29	°C/W
		ET Package on 4-layer PCB Based on JEDEC Standards	32	°C/W

¹ Additional thermal information available on the Allegro website.

Table of Contents

Specifications	2	PWM Dimming	16
Selection Guide	2	APWM Pin	17
Absolute Maximum Ratings	2	Extending LED Dimming Ratio	18
Thermal Characteristics	3	Analog Dimming	18
Functional Block Diagram	4	LED Short Detect	19
Pinout Diagrams and Terminal List	5	Overvoltage Protection	20
Characteristic Performance	10	Boost Switch Overcurrent Protection	21
Functional Description	12	Input Overcurrent Protection and Disconnect Switch	22
Enabling the IC	12	Setting the Current Sense Resistor	22
Powering Up: LED Pin Short-to-GND Check	12	Input UVLO	22
Powering Up: Boost Output Undervoltage	13	VDD	23
Soft-Start Function	14	Shutdown	23
Frequency Selection	14	Dithering Feature	24
SYNC	14	Fault Protection During Operation	25
LED Current Setting and LED Dimming	15	Application Information	28
		Design Example	32
		Package Outline Drawings	33

A8519 and A8519-1

*Wide Input Voltage Range, High-Efficiency,
Fault-Tolerant LED Driver*

Functional Block Diagram

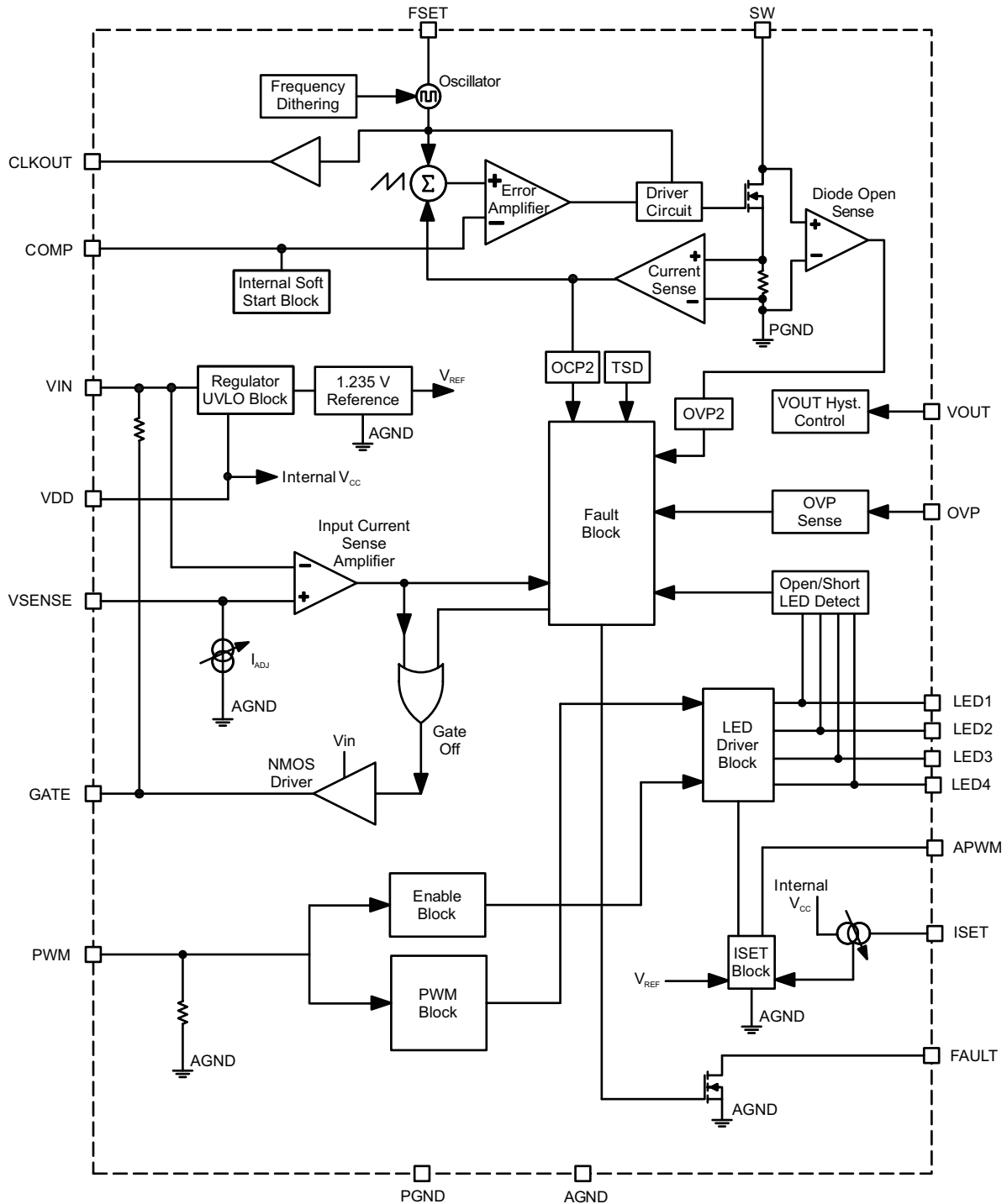

A8519 and A8519-1

*Wide Input Voltage Range, High-Efficiency,
Fault-Tolerant LED Driver*

PINOUT DIAGRAMS

20-Pin TSSOP with Exposed Thermal Pad (suffix LP)

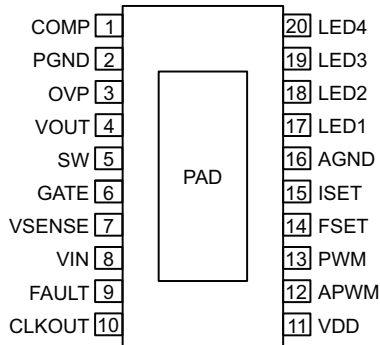

28-Pin QFN with Exposed Thermal Pad (suffix ET)

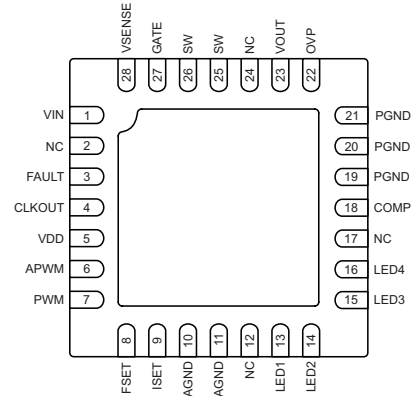

Terminal List Table

Pin Number		Name	Function
LP	ET		
1	18	COMP	Output of the error amplifier and compensation node. Connect an R _z -C _z -C _p network from this pin to GND for control loop compensation.
2	19,20,21	PGND	Power ground for internal N-channel MOSFET switching device. Connect to PCB ground plane.
3	22	OVP	Overvoltage protection. Connect external resistor from VOUT to this pin to adjust the overvoltage protection level.
4	23	VOUT	Connect directly to boost output voltage.
5	25,26	SW	The drain of the internal N-channel MOSFET switching device of the boost converter.
6	27	GATE	Output gate driver pin for external P-channel MOSFET control.
7	28	VSENSE	Connect this pin to the negative sense side of the current sense resistor R _{sc} . The threshold voltage is measured as V _{IN} -V _{SENSE} . There is also fixed current sink to allow for trip threshold adjustment.
8	1	VIN	Input power to the IC as well as the positive input used for current sense resistor.
9	3	FAULT	The pin is an open-drain type configuration that will be pulled low when a fault occurs. Connect a 100 kΩ resistor between this pin and desired logic level voltage.
10	4	CLKOUT	Logic output representing the switching frequency of internal boost oscillator. This allows other converters to be synchronized to the same frequency (with the same frequency dithering, if applicable)
11	5	VDD	Output of internal LDO (bias regulator). Connect a 1 μF decoupling capacitor between this pin and GND.
12	6	APWM	Analog trimming option or dimming. Applying a digital PWM signal to this pin adjusts the internal I _{ISET} current.
13	7	PWM	Enables the IC when this pin is pulled high. Also serves to control the LED intensity by using pulse-width modulation. Typical PWM dimming frequency is in the range of 100 to 400 Hz.
14	8	FSET	Frequency/synchronization pin. A resistor R _{FSET} from this pin to GND sets the switching frequency (with dithering superimposed). It can also be used to synchronize two or more converters in the system to an external frequency between 260 kHz and 2.3 MHz (dithering is disabled in this case).
15	9	ISET	Connect R _{ISET} resistor between this pin and GND to set the desired LED current setting.
16	10,11	AGND	LED current ground. Connect to PCB ground plane.
17,18, 19,20	13,14, 15,16	LED 1-4	LED current sinks #1 to 4. Connect the cathode of each LED string to associated pin. Unused LED pin must be terminated to GND through a 3.09 kΩ resistor.
-	2,12, 17,24	NC	No connect. Leave open or connect to GND.
-	-	PAD	Exposed pad of the package providing enhanced thermal dissipation. This pad must be connected to the ground plane(s) of the PCB with at least 8 vias, directly in the pad.

A8519 and A8519-1

Wide Input Voltage Range, High-Efficiency, Fault-Tolerant LED Driver

ELECTRICAL CHARACTERISTICS [1]: Unless otherwise specified, specifications are valid at $V_{IN} = 16\text{ V}$, $T_A = 25^\circ\text{C}$; ● indicates specifications guaranteed over the full operating temperature range with $T_A = T_J = -40^\circ\text{C}$ to 125°C ; typical specifications are at $T_A = 25^\circ\text{C}$

Characteristic	Symbol	Test Conditions	Min.	Typ.	Max.	Unit	
INPUT VOLTAGE							
Input Voltage Range [3]	V_{IN}		● 4.5	–	40	V	
UVLO Start Threshold	$V_{UVLOrise}$	V_{IN} rising	● –	–	4.35	V	
UVLO Stop Threshold	$V_{UVLOfall}$	V_{IN} falling	● –	–	3.9	V	
UVLO Hysteresis	$V_{UVLOHYS}$			300	450	600	mV
INPUT SUPPLY CURRENT							
Input Quiescent Current	I_Q	$V_{PWM} = V_{IH}$, $f_{SW} = 2\text{ MHz}$	● –	8	15	mA	
Input Sleep Supply Current	I_{SLEEP}	$V_{IN} = 16\text{ V}$, $V_{PWM} = V_{SYNC} = 0\text{ V}$	● –	2.0	10	μA	
INPUT LOGIC LEVELS (PWM, APWM)							
Input Logic Level Low	V_{IL}		● –	–	0.4	V	
Input Logic Level High	V_{IH}		● 1.5	–	–	V	
PWM Input Pull-Down Resistor	R_{EN}	$V_{PWM} = 5\text{ V}$		60	100	140	k Ω
APWM Input Pull-Down Resistor	R_{APWM}	$V_{PWM} = V_{IH}$		60	100	140	k Ω
APWM							
APWM Frequency [2]	f_{APWM}		● 40	–	1000	kHz	
OUTPUT LOGIC LEVELS (CLKOUT)							
Output Logic Level Low	V_{OL}	$5\text{ V} < V_{IN} < 40\text{ V}$	● –	–	0.3	V	
Output Logic Level High	V_{OH}	$5\text{ V} < V_{IN} < 40\text{ V}$	● 1.8	–	–	V	
ERROR AMPLIFIER							
Source Current	$I_{EA(source)}$	$V_{COMP} = 1.5\text{ V}$		–	–600	–	μA
Sink Current	$I_{EA(sink)}$	$V_{COMP} = 1.5\text{ V}$		–	+600	–	μA
COMP Pin Pull-Down Resistance	R_{COMP}	FAULT = 0, $V_{COMP} = 1.5\text{ V}$		–	1.4	–	k Ω
OVERVOLTAGE PROTECTION							
OVP Pin Voltage Threshold	$V_{OVP(th)}$	OVP pin connected to V_{OUT}	● 7	8.3	9.5	V	
OVP Pin Sense Current Threshold	$I_{OVP(th)}$	Current into OVP pin	● 190	200	210	μA	
OVP Pin Leakage Current	$I_{OVP(LKG)}$	$V_{IN} = 16\text{ V}$, PWM = L	● –	0.1	1	μA	
OVP Accuracy				–	–	5	%
Undervoltage Protection Threshold	$V_{UVP(th)}$	Measured at VOUT pin when $R_{OVP} = 160\text{ k}\Omega$ [2]		–	3	–	V
		Measured at VOUT pin when $R_{OVP} = 0$		–	0.55	0.7	V
Secondary Overvoltage Protection	$V_{OVP(sec)}$	Measured at SW pin	● 42	45	48	V	

Continued on the next page...

¹ For input and output current specifications, negative current is defined as coming out of the node or pin (sourcing); positive current is defined as going into the node or pin (sinking).

² Ensured by design and characterization, not production tested.

³ Minimum $V_{IN} = 4.5\text{ V}$ is only required at startup. After startup is completed, IC can continue to operate down to $V_{IN} = 3.9\text{ V}$

⁴ LED current is trimmed to cancel variations in both Gain and ISET voltage

A8519 and A8519-1

Wide Input Voltage Range, High-Efficiency, Fault-Tolerant LED Driver

ELECTRICAL CHARACTERISTICS [1]: Unless otherwise specified, specifications are valid at $V_{IN} = 16\text{ V}$, $T_A = 25^\circ\text{C}$; • indicates specifications guaranteed over the full operating temperature range with $T_A = T_J = -40^\circ\text{C}$ to 125°C ; typical specifications are at $T_A = 25^\circ\text{C}$

Characteristic	Symbol	Test Conditions	Min.	Typ.	Max.	Unit
BOOST SWITCH						
Switch On-Resistance	R_{SW}	$I_{SW} = 0.75\text{ A}$, $V_{IN} = 16\text{ V}$	• 100	250	500	m Ω
Switch Leakage Current	$I_{SW(LKG)}$	$V_{SW} = 16\text{ V}$, $V_{PWM} = V_{IL}$	• –	0.1	1	μA
Switch Current Limit	$I_{SW(LIM)}$		• 3	3.65	4.5	A
Secondary Switch Current Limit [2]	$I_{SW(LIM2)}$	Higher than max $I_{SW(LIM)}$ under all conditions part latches when detected	–	4.9	–	A
Minimum Switch On-Time	$t_{SW(on)}$		• 45	65	85	ns
Minimum Switch Off-Time	$t_{SW(off)}$		• –	65	85	ns
OSCILLATOR FREQUENCY						
Oscillator Frequency [5]	f_{SW}	$R_{FSET} = 10\text{ k}\Omega$	• 1.95	2.15	2.35	MHz
		$R_{FSET} = 21.5\text{ k}\Omega$	• 0.9	1	1.1	MHz
		$R_{FSET} = 110\text{ k}\Omega$	–	200	–	kHz
Oscillator Frequency Dithering Range	f_{SW_DITH}	$R_{FSET} = 10\text{ k}\Omega$	–	± 5	–	%
Dithering Modulation Frequency	f_{SW_MOD}	$R_{FSET} = 10\text{ k}\Omega$	–	12.5	–	kHz
FSET Pin Voltage	V_{FSET}	A8519, $R_{FSET} = 10\text{ k}\Omega$	–	1.02	–	V
		A8519-1, $R_{FSET} = 10\text{ k}\Omega$	–	1.07	–	V
SYNCHRONIZATION						
Sync Input Logic Level	V_{SYNCL}	FSET pin logic Low	• –	–	0.4	V
	V_{SYNCH}	FSET pin logic High	• 2	–	–	V
Synchronized PWM Frequency	$f_{SW(sync)}$		• 260	–	2300	kHz
Synchronization Input Min. Off-Time	$t_{SYNC(off)}$		• 150	–	–	ns
Synchronization Input Min. On-Time	$t_{SYNC(on)}$		• 150	–	–	ns
LED CURRENT SINKS						
LEDx Accuracy [4]	Err_{LED}	$R_{ISET} = 8.33\text{ k}\Omega$	• –	0.7	3	%
LEDx Matching	Δ_{LEDx}	$I_{ISET} = 120\text{ }\mu\text{A}$	• –	0.8	2	%
LEDx Regulation Voltage	V_{LEDx}	$V_{LED1} = V_{LED2} = V_{LED3} = V_{LED4}$, $I_{ISET} = 120\text{ }\mu\text{A}$	• 750	850	975	mV
ISET to I_{LEDx} Current Gain	A_{ISET}	$I_{ISET} = 120\text{ }\mu\text{A}$	• 696	710	727	A/A
ISET Pin Voltage	V_{ISET}		0.987	1.017	1.047	V
Allowable ISET Current	I_{ISET}		• 20	–	144	μA
V_{LEDx} Short detect	$V_{LEDx(SC)}$	While LED sinks are in regulation; sensed from V_{LEDx} to AGND	• 4.7	5.2	5.7	V
LED Startup Ramp Time [2]	t_{SS}	Time duration before all LED channels come into regulation, or OVP is tripped	–	20	–	ms

Continued on the next page...

¹ For input and output current specifications, negative current is defined as coming out of the node or pin (sourcing); positive current is defined as going into the node or pin (sinking).

² Ensured by design and characterization, not production tested.

³ Minimum $V_{IN} = 4.5\text{ V}$ is only required at startup. After startup is completed, IC can continue to operate down to $V_{IN} = 3.9\text{ V}$

⁴ LED current is trimmed to cancel variations in both Gain and ISET voltage

⁵ f_{SW} measurements were taken with dithering function is disabled.



A8519 and A8519-1

Wide Input Voltage Range, High-Efficiency, Fault-Tolerant LED Driver

ELECTRICAL CHARACTERISTICS [1]: Unless otherwise specified, specifications are valid at $V_{IN} = 16\text{ V}$, $T_A = 25^\circ\text{C}$; • indicates specifications guaranteed over the full operating temperature range with $T_A = T_J = -40^\circ\text{C}$ to 125°C ; typical specifications are at $T_A = 25^\circ\text{C}$

Characteristic	Symbol	Test Conditions	Min.	Typ.	Max.	Unit	
PWM DIMMING							
Maximum PWM Dimming Until Off-Time [2]	t_{PWML}	Measured while PWM = low, during dimming control and internal references are powered on (exceeding t_{PWML} results in shutdown)	–	32750	–	f_{sw} cycles	
Minimum PWM On-Time	$t_{PWMH(min1)}$	First cycle when powering up IC ($V_{PWM} = 0$ to 3.3 V)	•	0.75	2	μs	
	$t_{PWMH(min)}$	Subsequent PWM pulses	•	0.5	1	μs	
PWM High to LED On Delay	$t_{d(PWMon)}$	Time between PWM going high and when LED current reaches 90% of maximum ($V_{PWM} = 0$ to 3.3 V)	•	0.2	0.5	μs	
PWM Low to LED Off Delay	$t_{d(PWMOff)}$	Time between PWM going low and when LED current reaches 10% of maximum ($V_{PWM} = 3.3$ to 0 V)	•	0.36	0.5	μs	
HYSTERESIS CONTROL							
Hysteresis Window (A8519)	V_{HYST}	Measured at VOUT pin when PWM = H to L	–	0.35	–	V	
Hysteresis Window (A8519-1)	V_{HYST1}	Measured at VOUT pin when PWM = H to L	–	0.15	–	V	
GATE PIN							
Gate Pin Sink Current	$I_{G(sink)}$	$V_{GATE} = V_{IN}$, no input OCP fault	–	–113	–	μA	
Gate Pin Source Current	$I_{G(source)}$	$V_{GATE} = V_{IN} - 6\text{ V}$, input OCP fault tripped	–	6	–	mA	
Gate Shutdown Delay When Overcurrent Fault Is Tripped [2]	t_{FAULT}	$V_{IN} - V_{SENSE} = 200\text{ mV}$, monitored at FAULT pin	–	–	3	μs	
Gate Voltage	V_{GATE}	Measured between GATE and VIN when gate is on	–	–6.7	–	V	
VSENSE PIN							
VSENSE Pin Sink Current	I_{VSENSE}		•	17.2	21.5	25.8	μA
VSENSE Trip Point	$V_{SENSE(trip)}$	Measured between VIN and VSENSE, $R_{adj} = 0$	•	95	110	125	mV
FAULT PIN							
FAULT Pull-Down Voltage	V_{FAULT}	$I_{FAULT} = 1\text{ mA}$	–	–	0.5	V	
FAULT Pin Leakage Current	$I_{FAULT(1kg)}$	$V_{FAULT} = 5\text{ V}$	–	–	1	μA	
THERMAL PROTECTION (TSD)							
Thermal Shutdown Threshold [2]	T_{SD}	Temperature rising	–	155	170	–	$^\circ\text{C}$
Thermal Shutdown Hysteresis [2]	$T_{SD(hys)}$		–	–	20	–	$^\circ\text{C}$

¹ For input and output current specifications, negative current is defined as coming out of the node or pin (sourcing); positive current is defined as going into the node or pin (sinking).

² Ensured by design and characterization, not production tested.

³ Minimum $V_{IN} = 4.5\text{ V}$ is only required at startup. After startup is completed, IC can continue to operate down to $V_{IN} = 3.9\text{ V}$

⁴ LED current is trimmed to cancel variations in both Gain and ISET voltage

A8519 and A8519-1

Wide Input Voltage Range, High-Efficiency, Fault-Tolerant LED Driver

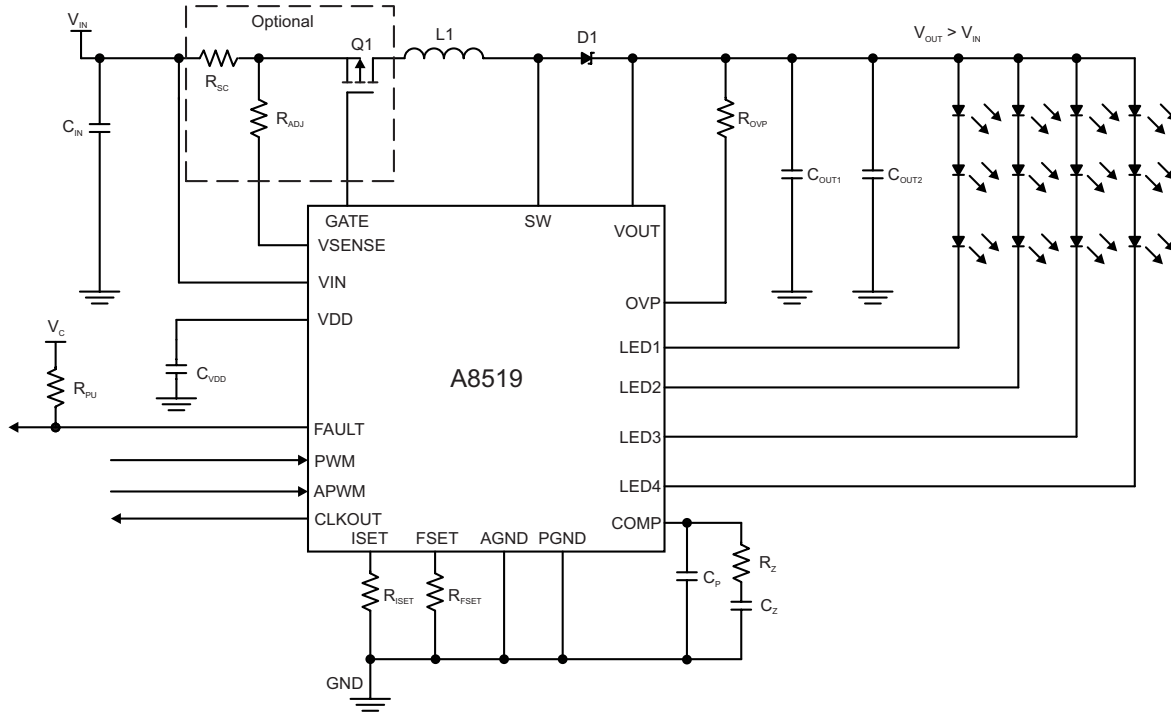

Typical Application Showing Boost Configuration with Input Disconnect Switch to Protect Against VOUT-to-Ground Short

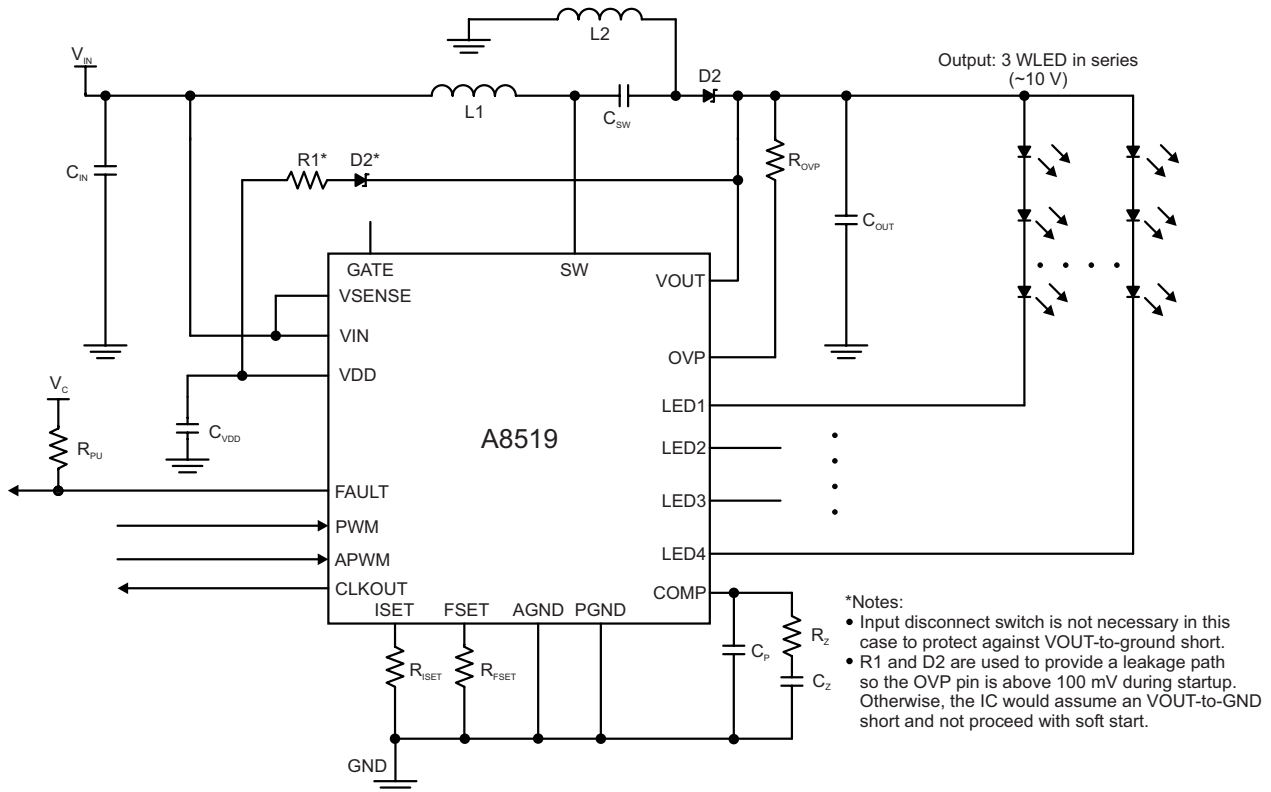

Typical Application Showing SEPIC Configuration for Flexible Input/Output Voltage Ratio

CHARACTERISTIC PERFORMANCE

Efficiency Measurement

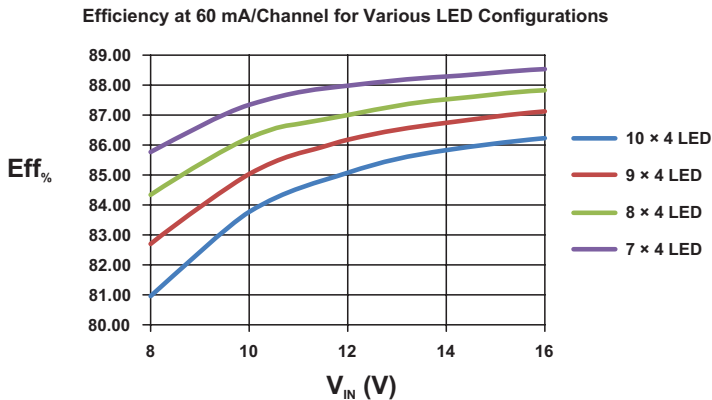

A8519 Evaluation Board Efficiency versus Input Voltage while Disconnect Switch and Snubber Circuit are Used

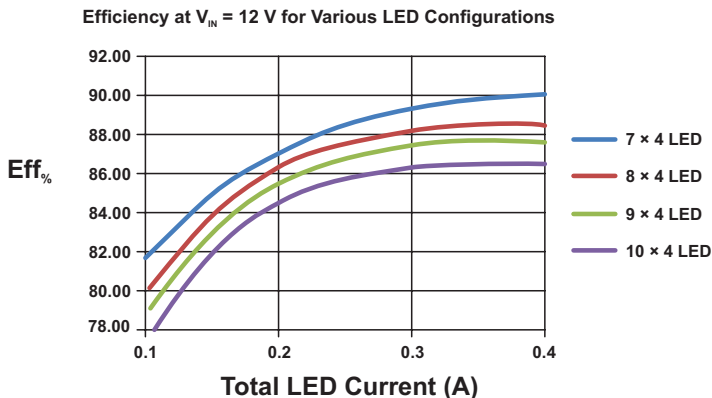

A8519 Evaluation Board Efficiency versus Total LED Current while Disconnect Switch and Snubber Circuit are Used

Higher efficiency can be achieved by:

- Using an inductor with low DCR.
- Using lower forward voltage drop and smaller junction capacitance Schottky diode.
- Removing the snubber circuit; however, this might compromise the EMI performance.
- Shorting out the disconnect switch and the input current sense resistor; however, this will eliminate the output short-to-GND protection feature.
- Lowering switching frequency. This will significantly improve the efficiency; however, to avoid the EMI AM band limits, careful switching frequency selection is required. In addition, a larger inductor will be needed.

Startup Waveforms

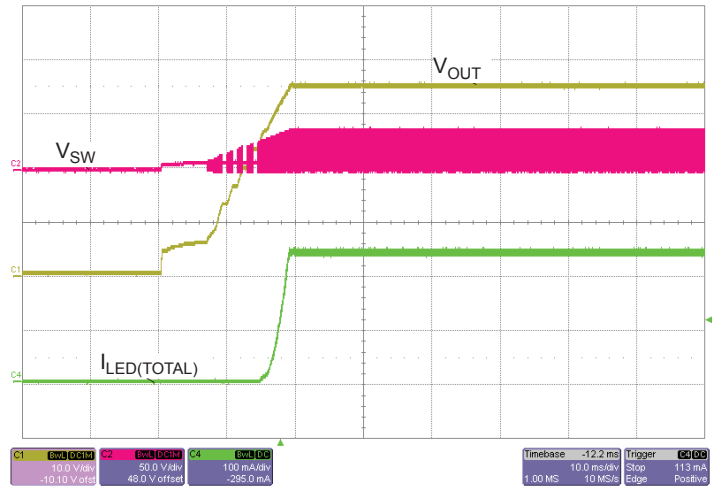

Start up at 100% PWM Dimming, V_{IN} = 7 V, 4 Channels, 10 LEDs/Channel, 60 mA/Channel; Time base = 10 ms/Div

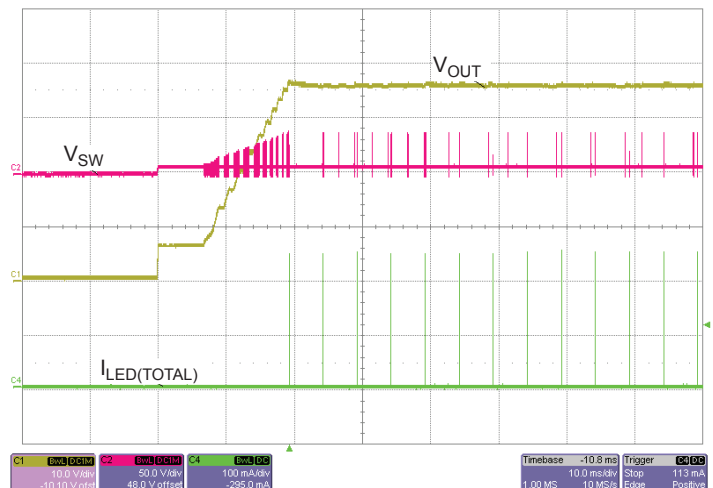

Start up at 0.02% PWM Dimming, V_{IN} = 7 V, 4 Channels, 10 LEDs/Channel, 60 mA/Channel; Time base = 10 ms/Div

Transient Response to Step Change in PWM Dimming

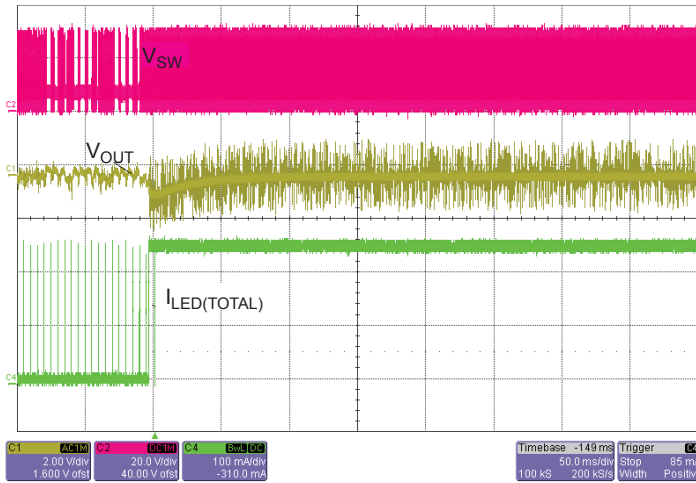

From PWM = 0.1% to PWM = 100% at 4 Channels,
60 mA/Channel, $V_{IN} = 12$ V; Time base = 50 ms/Div

Transient Response to Step Change in V_{IN} Voltage

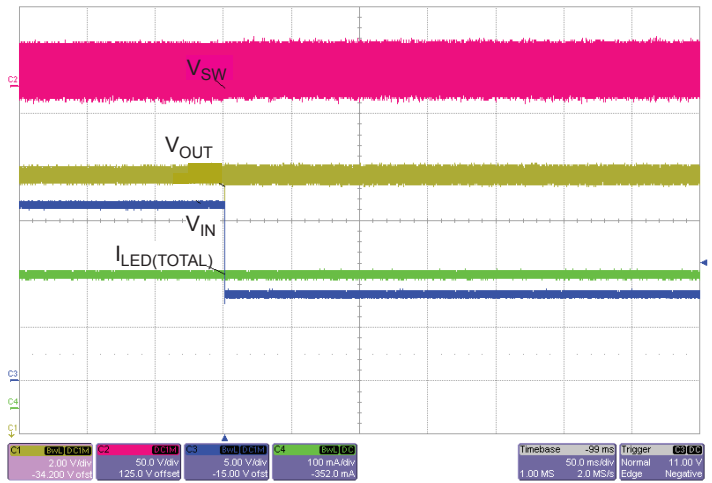

From $V_{IN} = 16$ V to $V_{IN} = 5.5$ V, 4 Channels, 60 mA/Channel,
PWM = 100%; Time base = 50 ms/Div

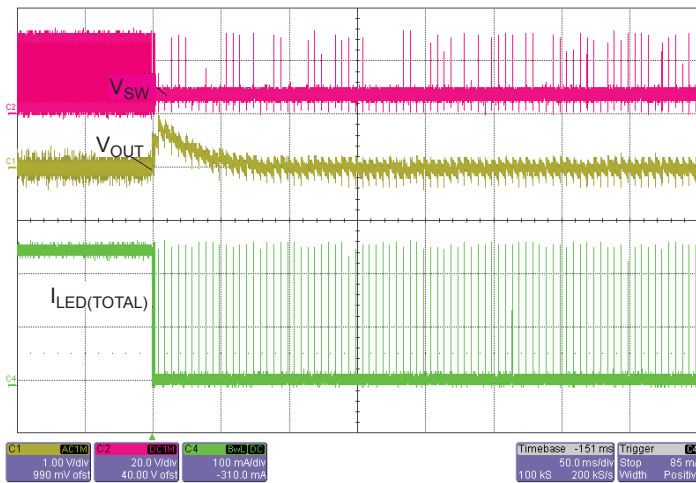

From PWM = 100% to PWM = 0.1% at 4 Channels,
60 mA/Channel, $V_{IN} = 12$ V; Time base = 50 ms/Div

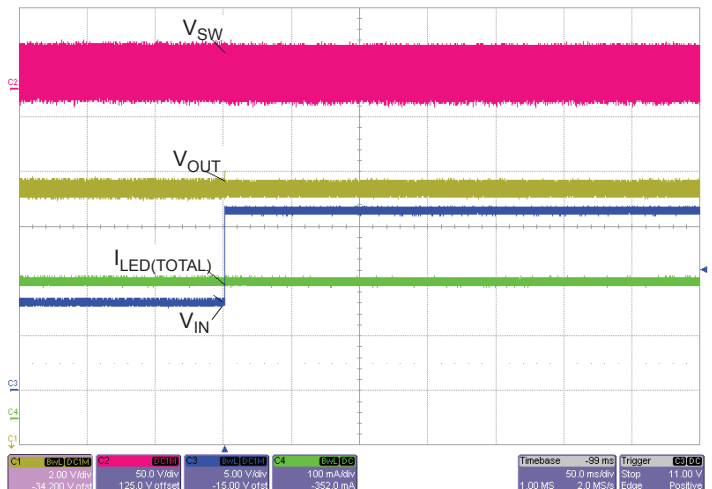

From $V_{IN} = 5.5$ V to $V_{IN} = 16$ V, 4 Channels, 60 mA/Channel,
PWM = 100%; Time base = 50 ms/Div

FUNCTIONAL DESCRIPTION

Enabling the IC

The IC turns on when a logic high signal is applied on the PWM pin with a minimum duration of t_{pPWMH} for the first clock cycle, and the input voltage present on the VIN pin is greater than 4.35 V to clear the UVLO threshold. Before the LEDs are enabled, the A8519 driver goes through a system check to see if there are any possible fault conditions that might prevent the system from functioning correctly. Also if the FSET pin is pulled low the IC will not power up. More information on the FSET pin can be found in the Synchronization section of the datasheet.

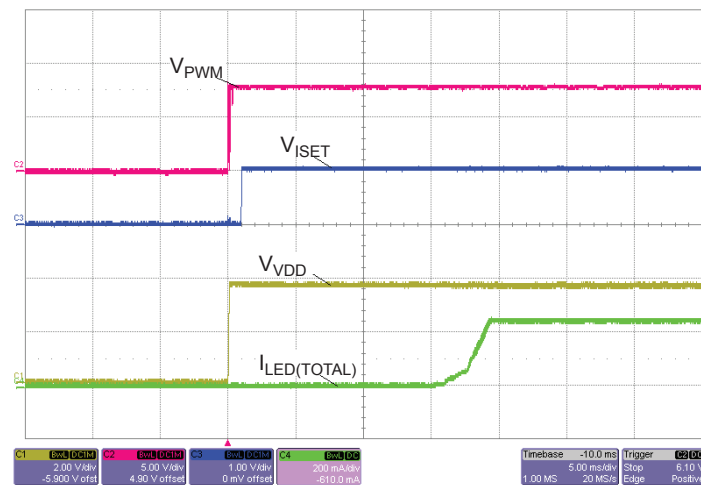

Figure 1: Power Up Diagram Showing PWM, ISET, and VDD Voltages and Total LED Current

Once the IC is enabled, there are only two ways to shut down the IC into low-power mode:

1. Pull PWM pin to low for at least 32,750 clock cycles (approximately 16 ms at 2 MHz).
2. Cut off the supply and allow V_{IN} to drop below UVLO falling threshold (less than 3.9 V).

Powering Up: LED Pin Check

Once VIN pin goes above UVLO and a high signal is present on the PWM pin, the IC proceeds to power up. The A8519 then enables the disconnect switch (GATE) and checks to see if the LED pins are shorted to ground and/or are not used. The LED detect phase starts when the GATE voltage of the disconnect switch is equal to $V_{IN} - 3.3$ V.

Figure 2 shows the relation of LEDx pins with respect to the gate voltage of the disconnect switch (if used) during LED detect phase, as well as the duration of the LED detect for a switching frequency of 2 MHz.

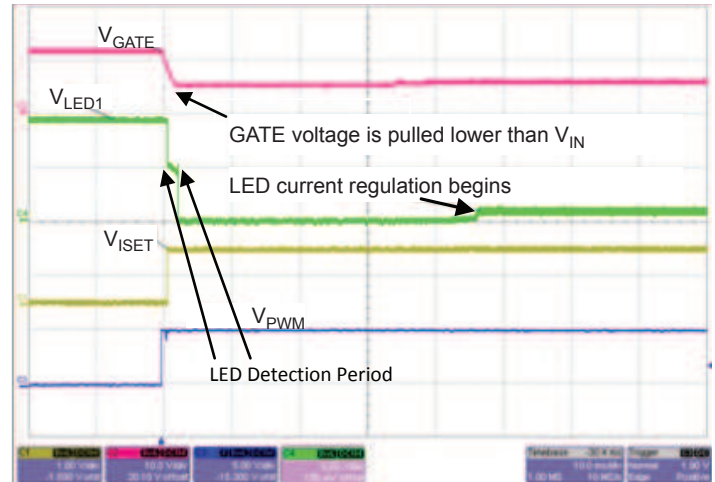

Figure 2: Power Up Diagram Showing Disconnect V_{GATE} , V_{LED1} , V_{ISET} , and V_{PWM} During LED Pins Detect and Regulation Period

When the voltage threshold on V_{LEDx} pins exceeds 120 mV, a delay between 3000 and 4000 clock cycles (1.5 to 2 ms) is used to determine the status of the pins.

Table 1: LED Detection Duration for Given Switching Frequency

Switching Frequency	Detection Time
2 MHz	1.5 to 2 ms
1 MHz	3 to 4 ms
800 kHz	3.75 to 5 ms
600 kHz	5 to 6.7 ms

All unused LED pins should be connected with a 3.09 kΩ resistor to GND. The unused pin, with the pull-down resistor, will be taken out of regulation at this point and will not contribute to the boost regulation loop.

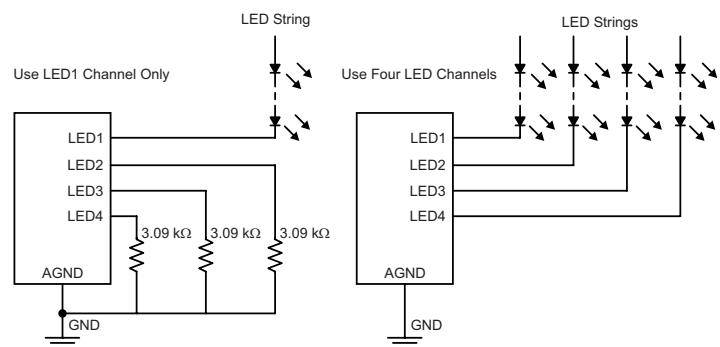

Figure 3: Channel Select Setup

Table 2: LED Detection Voltage Thresholds

LED Pin Voltage Level	LED Pin	Action
Less than 70 mV	Indicates a short to PCB GND	A8519 will not proceed with power up.
150 mV	Not used	LED string connected with the unused LED pin is removed from operation
325 mV	LED pin in use	None

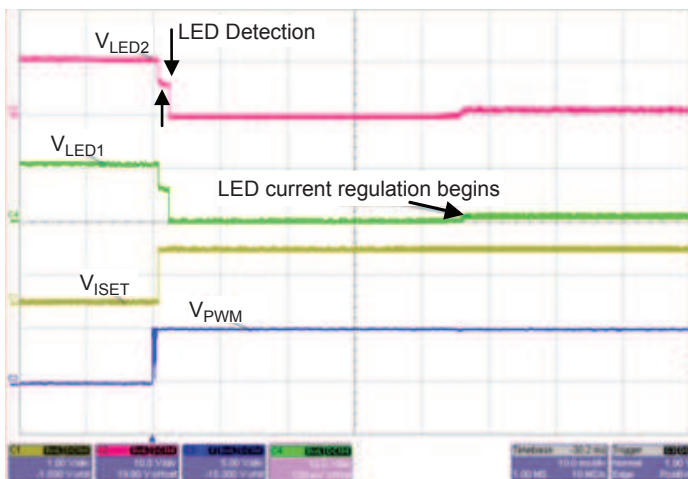

Figure 4: LED String Detect Occurs when All LED Strings are Selected to be Used

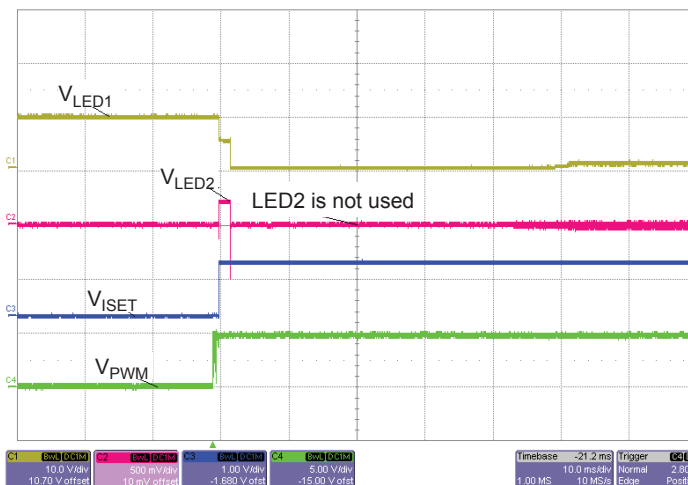

Figure 5: Detect Voltage is about 150 mV when LED Pin 2 is not Used

If an LED pin is shorted to ground, the A8519 will not proceed with soft-start until the short is removed from the LED pin. This prevents the A8519 from powering up and putting an uncontrolled amount of current through the LEDs.

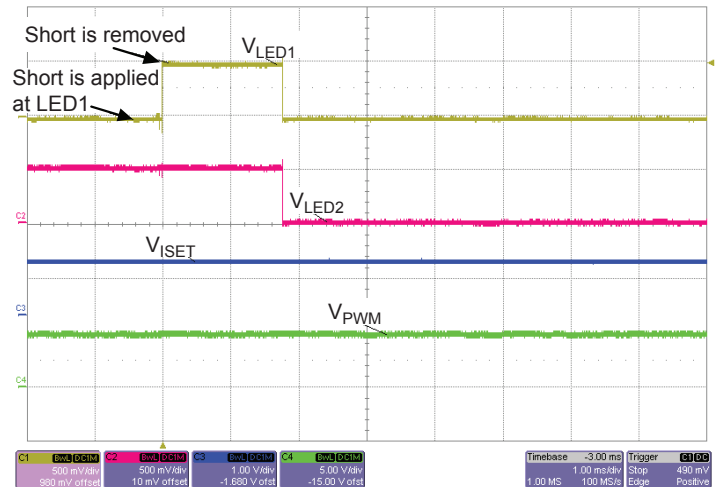

Figure 6: One LED Pin is Shorted to GND. The IC will not proceed with power up until LED pin is released, at which point the LED pin is checked to see if it is used.

Powering Up: Boost Output Undervoltage Protection

During startup, after the input disconnect switch has been enabled, the output voltage is checked through the OVP pin. If the sensed voltage does not rise above $V_{UVP(th)}$, the output is assumed to be at fault and the IC will not proceed with soft-start.

Undervoltage protection may be caused by one of the following faults:

- Output capacitor shorted to GND
- Boost inductor or diode open
- OVP sense resistor open

After an Output UVP fault has been detected, the A8519 immediately shuts down but does not latch off. It will retry as soon as the UVP fault is removed.

In case of output capacitor shorted to GND fault, however, the high inrush current will also trip the Input OCP fault. This causes the IC to shut down and latch off. To enable the IC again, the PWM pin must be pulled low for at least 32,750 clock cycles (about 16 ms at 2 MHz), then pulled high again.

Soft-Start Function

During startup, the A8519 ramps up its boost output voltage following a fixed ramp function. This technique limits the input inrush current and ensures the same startup time regardless of the PWM duty cycle.

The soft-start process is completed when any one of the following conditions is met:

1. All LED currents have reached their regulation targets,
2. Output voltage has reached 93% of its OVP threshold, or
3. Soft-start ramp time (t_{SS}) has expired.

Frequency Selection

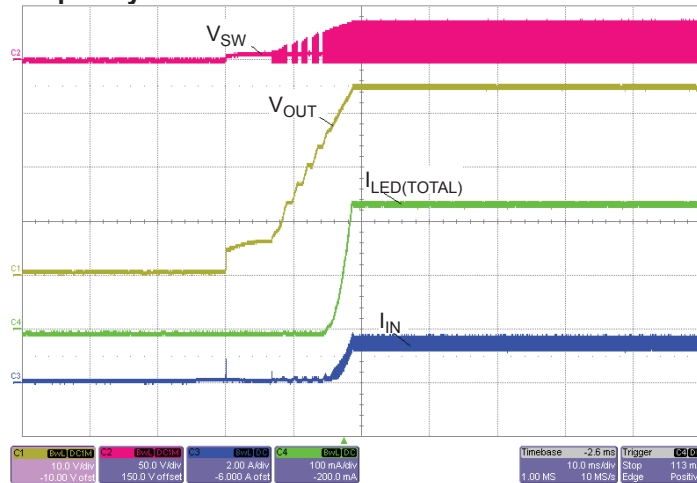

Figure 7: Startup Diagram Showing the Input Current, Output Voltage, Total LED Current, and Switch Node Voltage

The switching frequency on the boost regulator is set by a single resistor connected to the FSET pin. The switching frequency can be anywhere from 200 kHz to 2.15 MHz. Figure 8 shows typical switching frequency in MHz for a given resistor value (in kΩ). The following equation can also be used to determine typical switching frequency from FSET resistance:

$$f_{SW} = 21.4/R_{FSET} + 0.008$$

where f_{SW} is in MHz, R_{FSET} is in kΩ.

If a fault occurs during operation that will increase the switching frequency, the FSET pin is clamped to a maximum switching frequency of no more than 3.5 MHz. If the FSET pin is shorted to GND, the part will shut down. For more details, see the Fault Mode table on page 25.

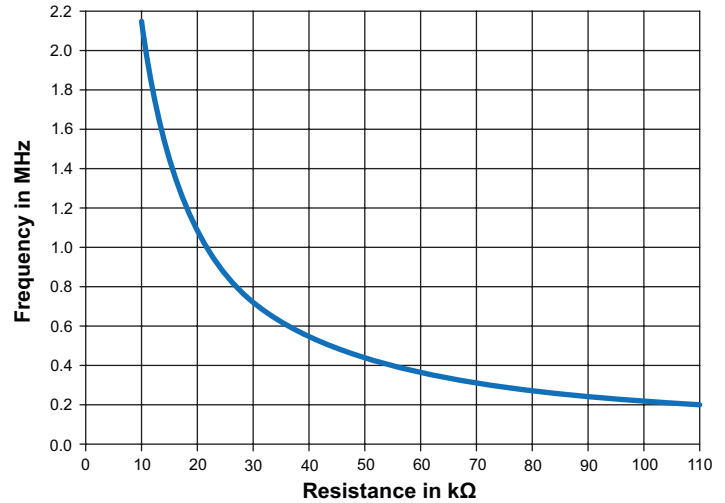

Figure 8: Switching Frequency versus R_{FSET} Resistor

Synchronization

The A8519 can also be synchronized using an external clock. At power-up, if the FSET pin is held low, the IC will not power-up. Only when the FSET pin is tri-stated to allow for the pin to rise to about 1 V, or when a sync clock is detected, the A8519 will try to power up. The basic requirement of the sync signal is 150 ns minimum on-time and 150 ns minimum off-time as dictated by the requirements of pulse-width on- and off-times.

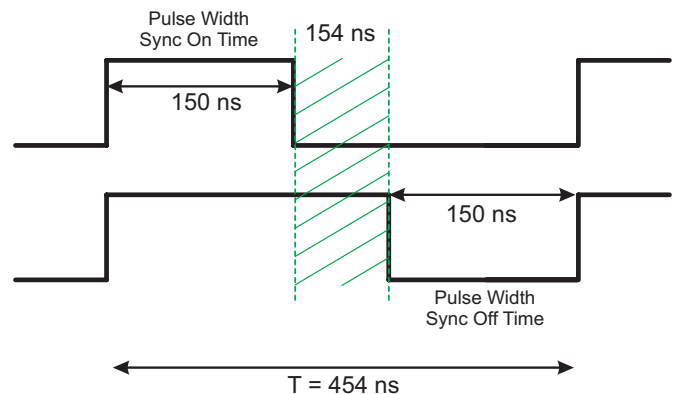

Figure 9: Sync Pulse On- and Off-Time Requirements

Figure 9 shows timing for a synchronization clock into the A8519 at 2.2 MHz.

Any pulse with a duty cycle of 33% to 66% at 2.2 MHz can be used to synchronize the IC. Table 3 summarizes the duty cycle range at various synchronization frequencies.

Table 3: Sync Pulse Duty Cycle Range for Selected Switching Frequencies.

Sync Pulse Frequency	Duty Cycle Range
2.2 MHz	33% to 66%
2 MHz	30% to 70%
1 MHz	15% to 85%
600 kHz	9% to 91%
300 kHz	4.5% to 95.5%

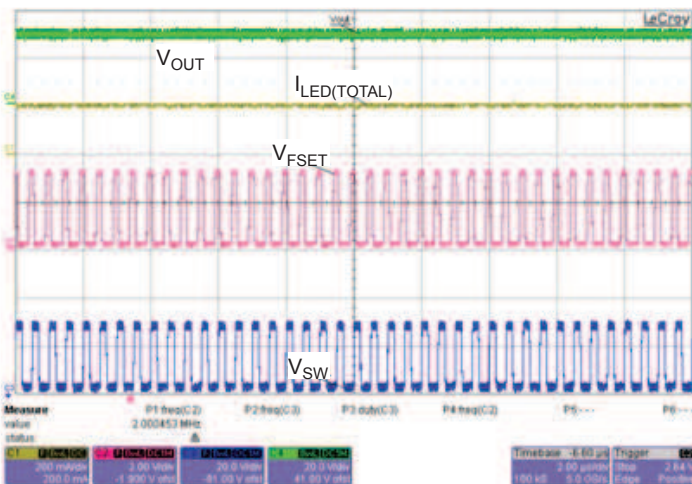

Figure 10: Synchronized FSET Pin and Switch Node SW Voltage.

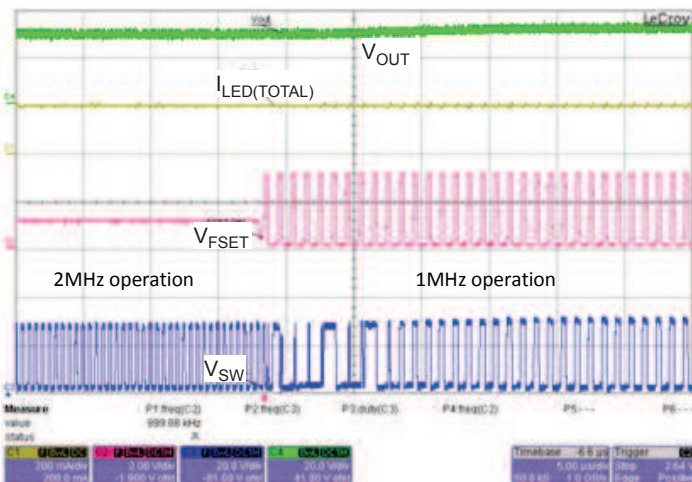

Figure 11: Transition of the Switch Wave Form when the Sync Pulse is Detected. The A8519 is switching at 2 MHz, and the applied sync pulse is 1 MHz. The LED current does not show any variation while the frequency changeover occurs.

Suppose the A8519 is started up with a valid external SYNC signal, but the SYNC signal is lost during normal operation. In that case, one of the following happens:

- If the external SYNC signal is high impedance (open), the A8519 continues normal operation after approximately 5 μ s, at the switching frequency set by R_{FSET} . No FAULT flag is generated.
- If the external SYNC signal is stuck low (shorted to ground), the A8519 will detect an FSET-short-to-GND fault. The FAULT pin is pulled low after approximately 10 μ s, and switching is disabled. Once the FSET pin is released or SYNC signal is detected again, the A8519 will proceed to soft-start.

To prevent generating a fault when the external SYNC signal is stuck at low, the circuit shown in Figure 12 can be used. When the external SYNC signal goes low, the A8519 will continue to operate normally at the switching frequency set by the R_{FSET} . No FAULT flag is generated.

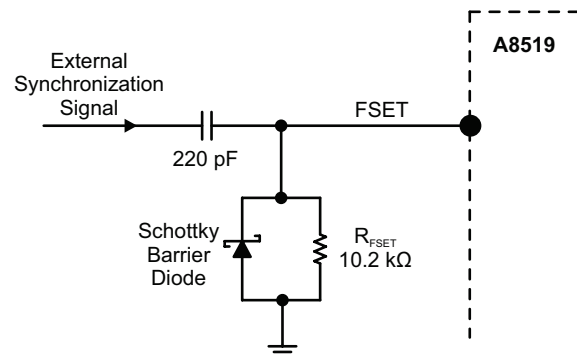

Figure 12: Countermeasure to Prevent External Sync Signal Stuck-at-Low Fault.

LED Current Setting and LED Dimming

The maximum LED current can be up to 100 mA per channel, and is set through the ISET pin. Connect a resistor, R_{ISET} , between this pin and GND. To set I_{LED} calculate R_{ISET} as follows:

$$I_{LED} = I_{SET} \times A_{ISET}$$

$$I_{SET} = \frac{V_{ISET}}{R_{ISET}}$$

$$R_{ISET} = \frac{(V_{ISET} \times A_{ISET})}{I_{LED}}$$

where I_{LED} current is in A and R_{ISET} is in Ω .

A8519 and A8519-1

Wide Input Voltage Range, High-Efficiency, Fault-Tolerant LED Driver

This sets the maximum current through the LEDs, referred to as the 100% current.

Table 4: LED Current Setting Resistors (Values Rounded to the Nearest Standard Resistor Value)

Standard Closest R_{ISET} Resistor Values	LED Current I_{LED}
7.15 k Ω	100 mA per LED
8.87 k Ω	80 mA per LED
11.8 k Ω	60 mA per LED
14.3 k Ω	50 mA per LED
17.8 k Ω	40 mA per LED

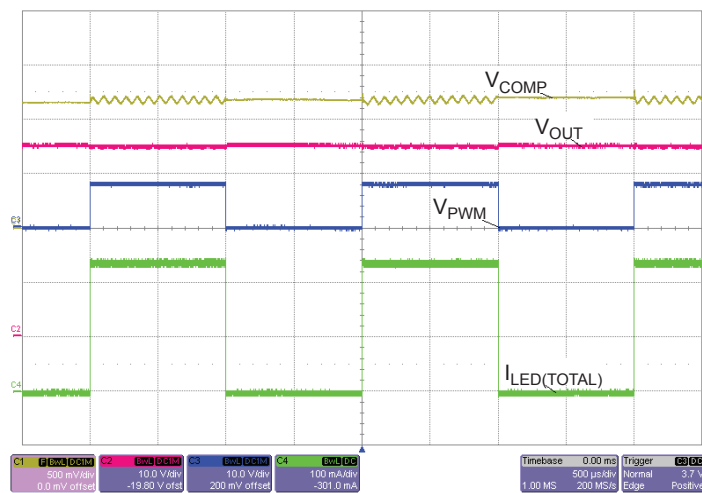

Figure 13: Typical PWM Diagram Showing V_{OUT} , I_{LED} and COMP Pin, as well as the PWM Signal. (PWM dimming Frequency is 500 Hz 50% duty cycle.)

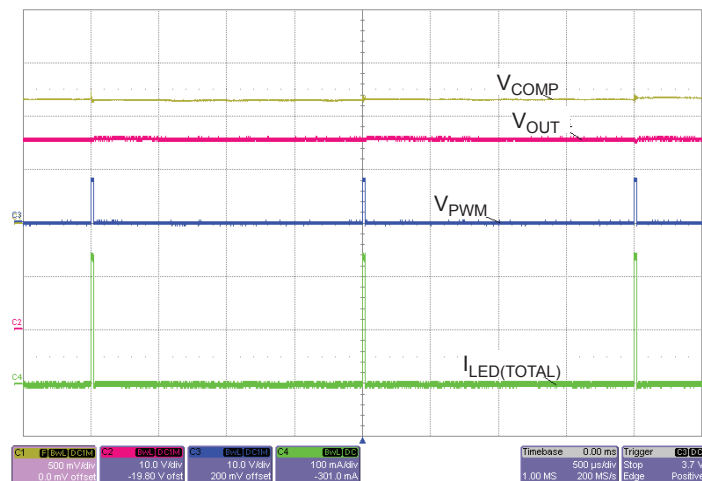

Figure 14: Typical PWM Diagram Showing V_{OUT} , I_{LED} , and COMP Pin, as well as the PWM Signal. (PWM dimming frequency is 500 Hz 1% duty cycle.)

PWM Dimming

The LED current can be reduced from the 100% current level by PWM dimming using the PWM pin. When the PWM pin is pulled high, the A8519 turns on and all enabled LEDs sink 100% current. When PWM is pulled low, the boost converter and LED sinks are turned off. The compensation (COMP) pin is floated, and critical internal circuits are kept active. The typical PWM dimming frequencies fall between 200 Hz and 1 kHz.

The A8519 is designed to deliver a maximum dimming ratio of 10,000:1 at PWM frequency of 100 Hz. That means a minimum PWM duty cycle of 0.01%, or an on-time of just 1 μ s out of a period of 10 ms.

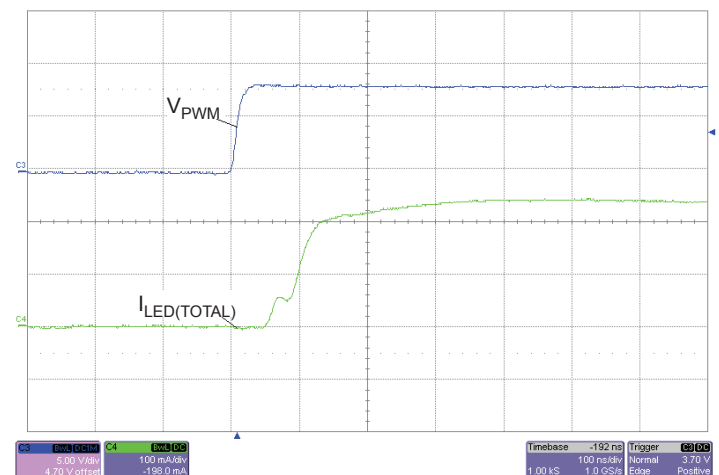

Figure 15: Rising Edge PWM Signal to Total LED Current $I_{LED(TOTAL)}$ Turn-On Delay; Time base = 100 ns

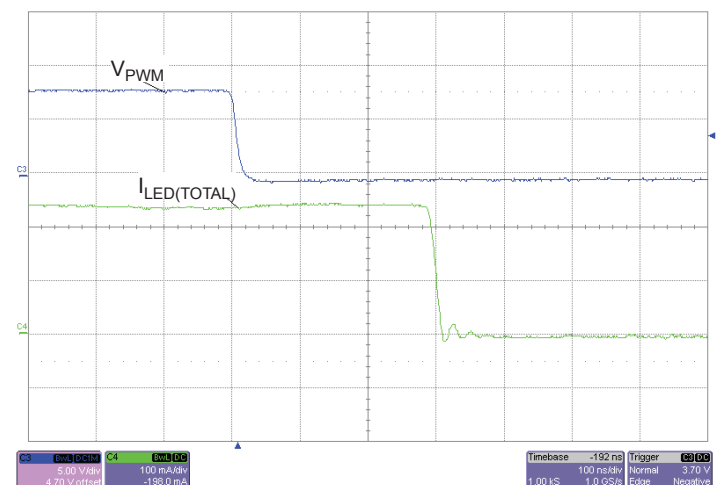

Figure 16: Falling Edge PWM Signal to Total LED Current $I_{LED(TOTAL)}$ Turn-Off Delay; Time base = 100 ns

High-PWM dimming ratio is achieved by regulating the output voltage during PWM off-time. The VOUT pin samples the output voltage during PWM on-time and regulates it during off-time. A hysteresis control loop brings VOUT higher by approximately 350 mV (150 mV for A8519-1) whenever it drops below the target voltage. In a highly noisy switching environment, it is necessary to insert an RC filter at the VOUT pin. A typical value of $R = 10\text{ k}\Omega$ and $C = 47\text{ pF}$ is recommended.

Another important feature of the A8519 is the PWM signal to LED current delay. This delay is typically less than 500 ns, which allows for greater LED current accuracy at low-PWM dimming duty cycles.

The error introduced by LED turn-on delay is partially offset by LED turn-off delay. Therefore, a PWM pulse width of under $1\text{ }\mu\text{s}$ is still feasible, but the percentage error of LED current will increase with narrower pulse width.

APWM Pin

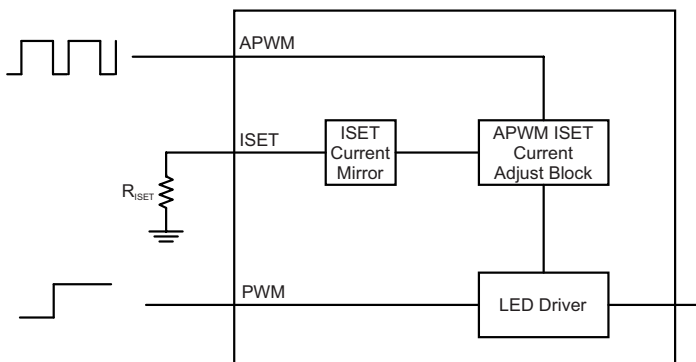

Figure 17: Simplified Block Diagram of APWM ISET Block

The APWM pin is used in conjunction with the ISET pin (see Figure 17). This is a digital signal pin that internally adjusts the I_{ISET} current. The typical input signal frequency is between 40 kHz and 1 MHz. The duty cycle of this signal is inversely proportional to the percentage of current that is delivered to the LED (see Figure 18). As an example, a system that delivers $I_{\text{LED(TOTAL)}} = 240\text{ mA}$ would deliver $I_{\text{LED(TOTAL)}} = 180\text{ mA}$ when an APWM signal with a duty cycle of 25% is applied. When this pin is not used it should be tied to AGND.

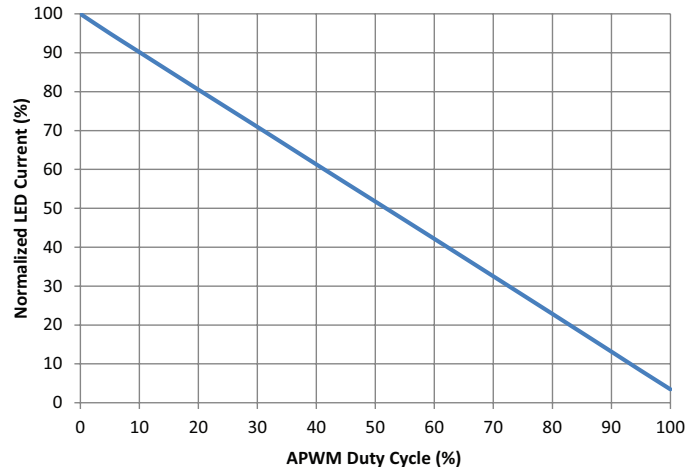

Figure 18: Normalized LED Current vs. APWM Duty Cycle
 $V_{\text{IN}} = 9\text{ V}$, $V_{\text{OUT}} = \sim 22\text{ V}$, $R_{\text{ISET}} = 24\text{ k}\Omega$, APWM = 200 kHz

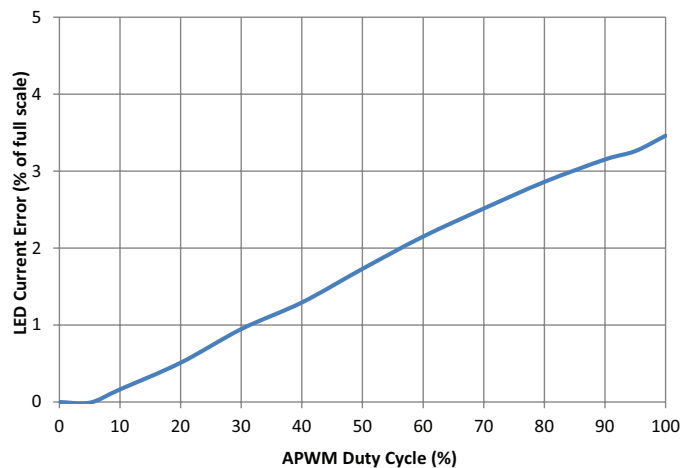

Figure 19: Error in LED Current vs. APWM Duty Cycle
 $V_{\text{IN}} = 9\text{ V}$, $V_{\text{OUT}} = \sim 22\text{ V}$, $R_{\text{ISET}} = 24\text{ k}\Omega$, APWM = 200 kHz

To use the APWM pin as a trim function, the user should set the maximum output current to a value higher than the desired current by at least 5%. The LED I_{ISET} current is then trimmed down to the appropriate desired value. Another consideration is the limitation of the APWM signal's duty cycle. In some cases, it might be more desirable to set the maximum I_{ISET} current to be 25% to 50% higher, thus allowing the APWM signal to have duty cycles that are between 25% and 50%.

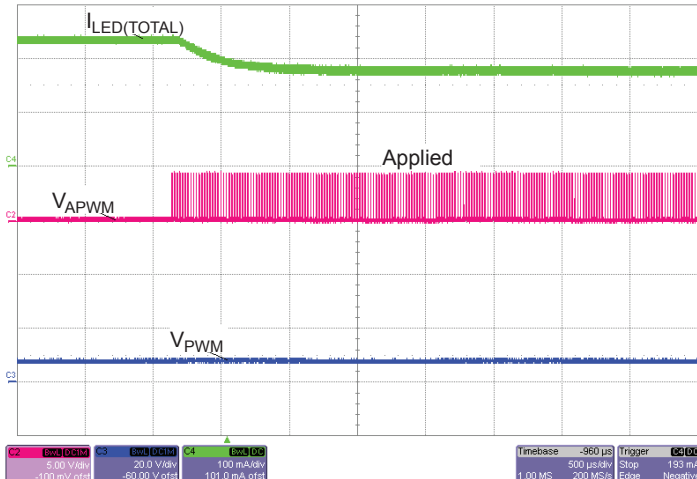

Figure 20: Transition of Total LED Current from 240 mA to 180 mA, when a 25% APWM signal is applied to the APWM pin. (Dimming PWM = 100%)

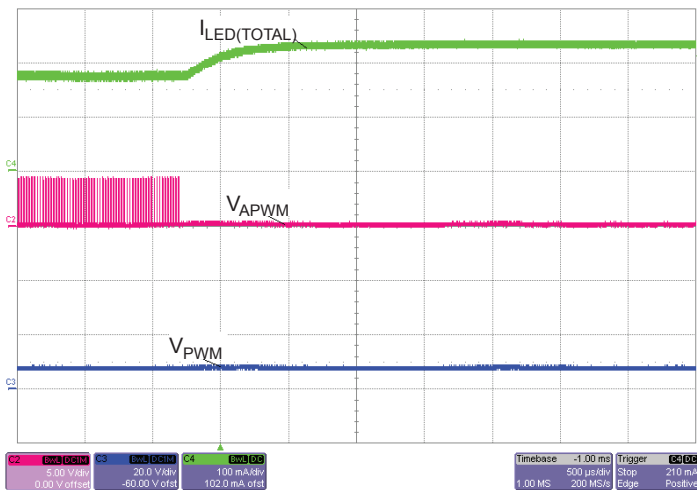

Figure 21: Transition of Total LED Current from 180 mA to 240 mA, when a 25% APWM stops being applied to the APWM pin. (Dimming PWM = 100%)

Although the APWM dimming function has a wide frequency range, if used strictly as an analog dimming function, it is recommended to use frequency ranges between 50 and 500 kHz for best accuracy. The frequency range needs to be considered only if the user is not using APWM as a closed-loop trim function. It takes about 1 millisecond to change the actual LED current due to propagation delay between the APWM signal and the $I_{LED(TOTAL)}$.

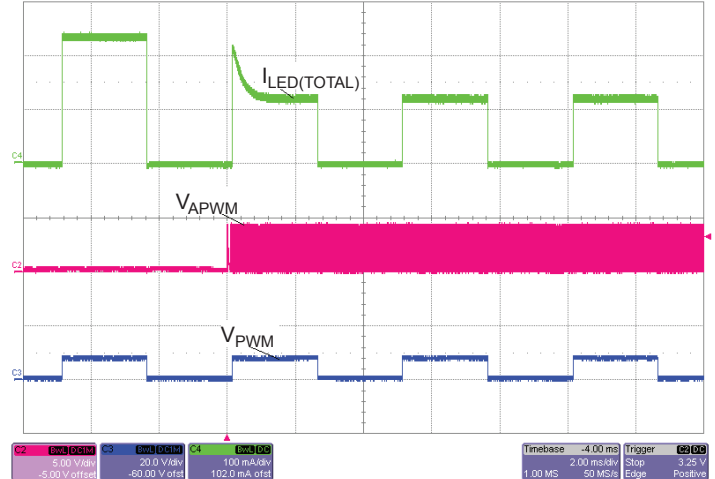

Figure 22: Transition of output current level when a 50% duty cycle APWM signal is applied to the APWM pin, in conjunction with 50% duty cycle applied to the PWM pin.

Extending LED Dimming Ratio

The dynamic range of LED brightness can be further extended by using a combination of PWM duty cycle, APWM duty cycle, and analog dimming method.

For example, the following approach can be used to achieve a 50,000:1 dimming ratio at 200 Hz PWM frequency:

- Vary PWM duty cycle from 100% down to 0.02% to give 5,000:1 dimming.
- With PWM duty cycle at 0.02%, vary APWM duty from 0% to 90% to reduce LED current down to 10%. This gives a net effect of 50,000:1 dimming.

Analog Dimming

Besides using APWM signal, the LED current can also be reduced by using an external DAC or another voltage source. Connect R_{ISET} between the DAC output and the ISET pin. The limit of this type of dimming is dependant of the range of the ISET pin. In the case of the A8519, the limit is 20 to 144 μ A.

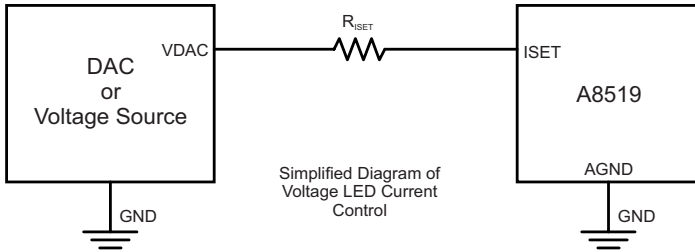

Figure 23: Typical Application Circuit Using a DAC to Control the LED Current in the A8519

The ISET current is controlled by the following formula:

$$I_{ISET} = \frac{V_{ISET} - V_{DAC}}{R_{ISET}}$$

where V_{ISET} is the ISET pin voltage and V_{DAC} is the DAC output voltage.

When the DAC voltage is 0 V, the LED current will be at its maximum. To keep the internal gain amplifier stable, do not decrease the current through the R_{ISET} resistor to less than 20 μ A.

Below is a typical application circuit using a DAC to control the LED current using a two-resistor configuration. The advantage of this circuit is that the DAC voltage can be higher or lower, thus adjusting the LED current to a higher or lower value of the preset LED current set by the R_{ISET} resistor.

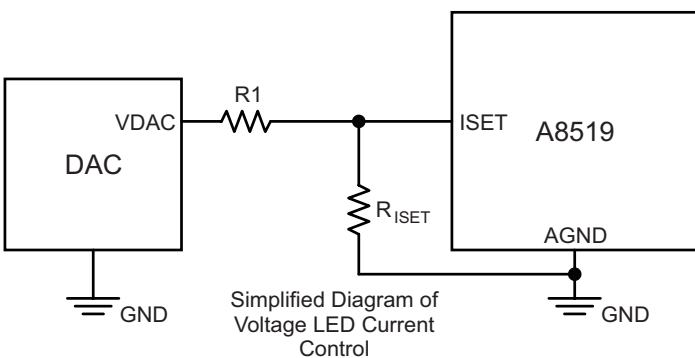

Figure 24: Typical Application Circuit Using a DAC and R_{ISET} Resistor to Control the LED Current in the A8519

The LED current can be adjusted using the following formula:

$$I_{ISET} = \frac{V_{ISET}}{R_{ISET}} - \left[\frac{V_{DAC} - V_{ISET}}{RI} \right]$$

where V_{ISET} is the ISET pin voltage and V_{DAC} is the DAC output voltage.

When V_{DAC} is equal to 1 V, the output is strictly controlled by the R_{ISET} resistor. When V_{DAC} is higher than 1 V, the LED current is reduced. When V_{DAC} is lower than 1 V, the LED current is increased.

LED String Short Detect

All LEDx pins are capable of handling the maximum V_{OUT} that the converter can deliver, thus allowing for LEDx pin to V_{OUT} protection in case of a connector short.

In case some of the LEDs in an LED string are shorted, the voltage at the corresponding LEDx pin will increase. Any LEDx pin that has a voltage exceeding $V_{LEDx(SC)}$ will be removed from operation. This will prevent the IC from dissipating too much power by having a large voltage present on an LEDx pin.

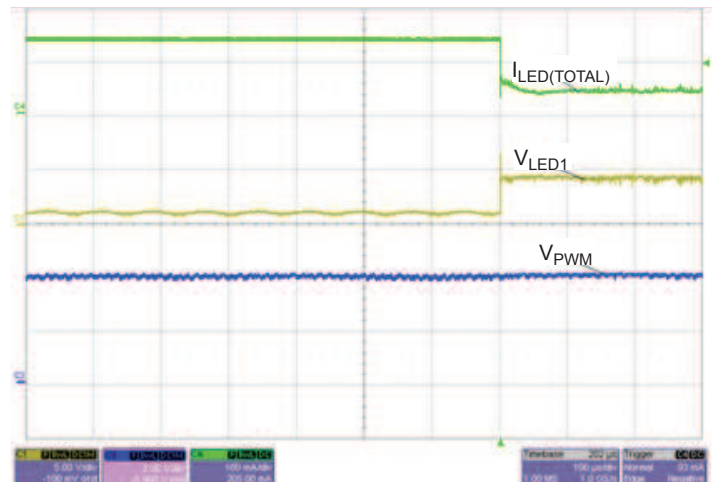

Figure 25: Disabling of LED1 String when the LED1 Pin Voltage is Increased Above 4.6 V

While the IC is being PWM dimmed, the IC will recheck the disabled LED every time the PWM signal goes high to prevent false tripping of LED short. This also allows for some self-correction if an intermittent LED pin short-to-V_{OUT} is present.

At least one LED must be in regulation for the LED string short-detect protection to activate. In case all of the LED pins are above regulation voltage (this could happen when the input voltage rises too high for the LED strings), they will continue to operate normally.

Overvoltage Protection

The A8519 has output overvoltage protection (OVP) and open Schottky diode protection (secondary OVP). The OVP pin has a threshold level of 8.3 V typical. A resistor can be used to set the output overvoltage protection threshold up to 40 V approximately. This is sufficient for driving 11 white LED in series.

The formula for calculating the OVP resistor is shown below:

$$R_{OVP} = \frac{(V_{OVP} - V_{OVP(th)})}{I_{OVP(th)}}$$

where V_{OVP(th)} = 8.3 V typical and I_{OVP(th)} = 200 μA typical.

The OVP function is not a latched fault. If the OVP condition occurs during a load dump, the IC will stop switching but not shut down.

There are several possibilities why an OVP condition is encountered during operation, the two most common being an open LED string and a disconnected output condition.

Figure 26 illustrates when the output of the A8519 is disconnected from load during normal operation. The output voltage instantly increases up to OVP voltage level, and then the boost stops switching to prevent damage to the IC. When the output voltage decreases to a low value, the boost converter will begin switching. If the condition that caused the OV event still exists, OVP will be triggered again.

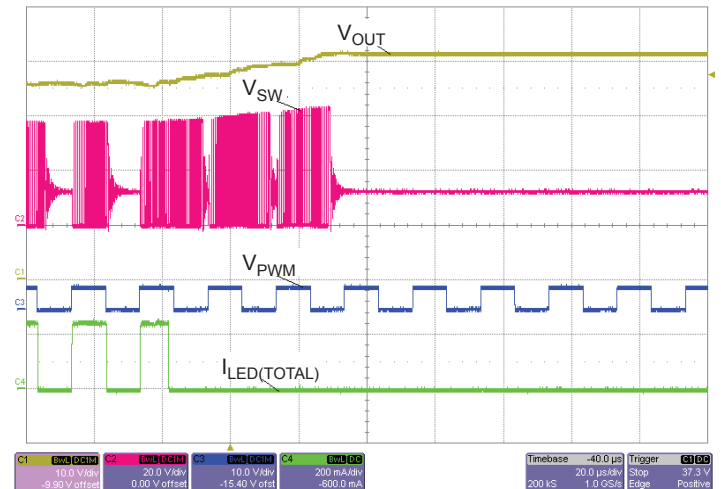

Figure 26: Output of A8519 when Disconnected from Load During Normal Operation

Figure 27 illustrates a typical OVP condition caused by an open LED string. Once OVP is detected, the boost stops switching, and the open LED string is removed from operation. Afterwards, V_{OUT} is allowed to fall, the boost will resume switching, and the A8519 will resume normal operation.

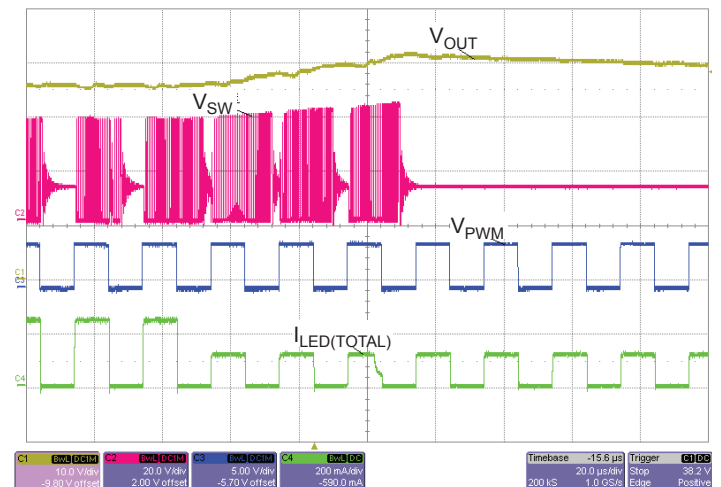

Figure 27: Typical OVP Condition Caused by an Open LED String

The A8519 also has built-in secondary overvoltage protection to protect the internal switch in the event of an open-diode condition. Open Schottky diode detection is implemented by detecting overvoltage on the SW pin of the device. If voltage on the SW pin exceeds the device's safe operating voltage rating, the A8519 disables and remains latched. To clear this fault, the IC must be shut down by either using the PWM signal or by going below the UVLO threshold on the VIN pin.

Figure 28 illustrates open Schottky diode protection while the IC is in normal operation. As soon as the switch node voltage (V_{SW}) exceeds 48 V, the IC will shut down. Due to small delays in the detection circuit, as well as there being no load present, the switch node voltage (V_{SW}) will rise above the trip point voltage.

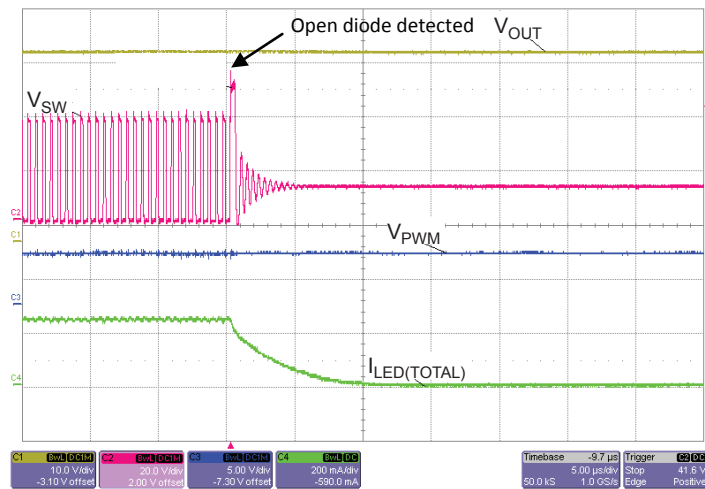

Figure 28: Open Schottky Diode Protection

When enabling the A8519 into an open-diode condition, the IC will first go through all of its initial LED detection and will then check the boost output voltage. At that point, the open diode is detected.

Boost Switch Overcurrent Protection

The boost switch is protected with cycle-by-cycle current limiting set at a minimum of 3 A. Figure 29 illustrates the normal operation of the switch node (V_{SW}), inductor current, and output voltage (V_{OUT}) for a 11×4 LED configuration.

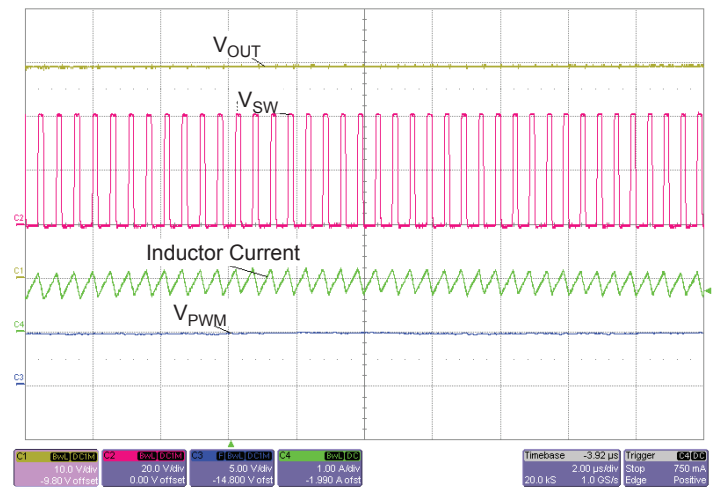

Figure 29: Normal Operation of Switch Node (V_{SW}), Inductor Current, and Output Voltage (V_{OUT})

Figure 30 shows the cycle-by-cycle current limit showing inductor current as a green trace. Note the inductor current is truncated and as a result the output voltage is reduced as compared to normal operation shown for the 11×4 LED configuration.

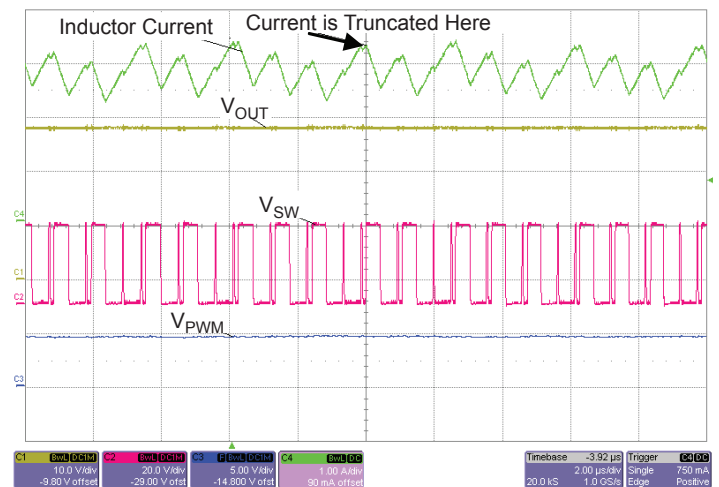

Figure 30: Cycle-by-Cycle Current Limit

There is also a secondary current limit ($I_{SW(LIM2)}$) that is sensed through the boost switch. This current limit, once detected, immediately shuts down the A8519. The level of this current limit is set above the cycle-by-cycle current limit to protect the switch from destructive currents when boost inductor is shorted. Figure 31 shows the secondary boost switch OCP. Once this limit is reached, the A8519 will immediately shut down.

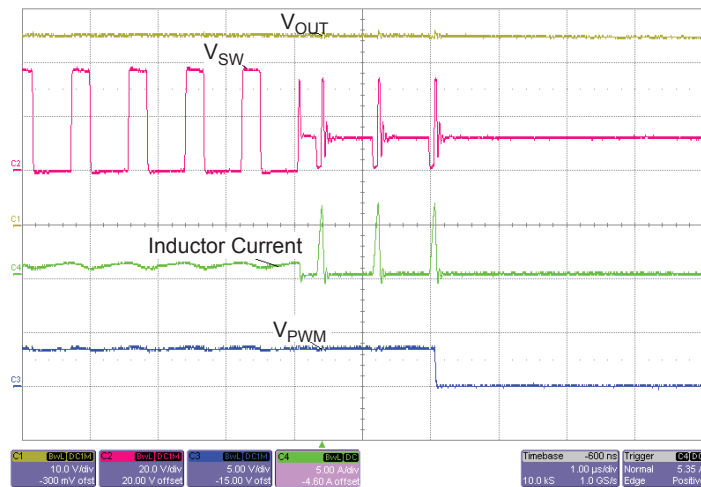

Figure 31: Secondary Boost Switch OCP

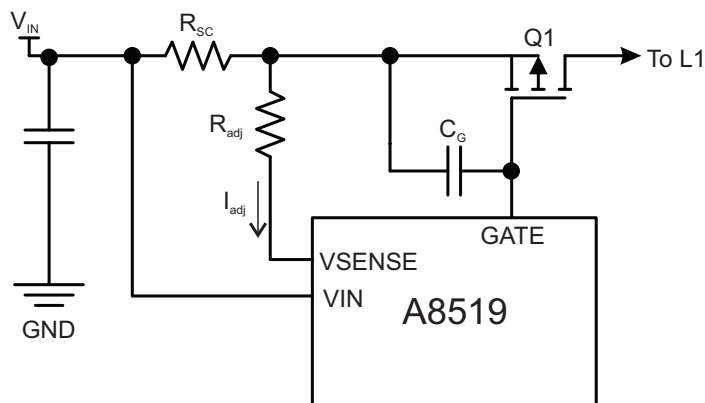

Figure 32: Typical Circuit Showing Implementation of Input Disconnect Feature

Input Overcurrent Protection and Disconnect Switch

The primary function of the input disconnect switch is to protect the system and the device from catastrophic input currents during a fault condition.

If the input current level goes above the preset current limit threshold, the part will be shut down in less than 3 μ s—this is a latched condition. The fault flag is also set low to indicate a fault. This protection feature prevents catastrophic failure in the system due to a short of the inductor, inductor short to GND, or short at the output GND. Figure 33 illustrates the typical input overcurrent fault condition. As soon as input OCP limit is reached, the part disables the gate of the disconnect switch Q1.

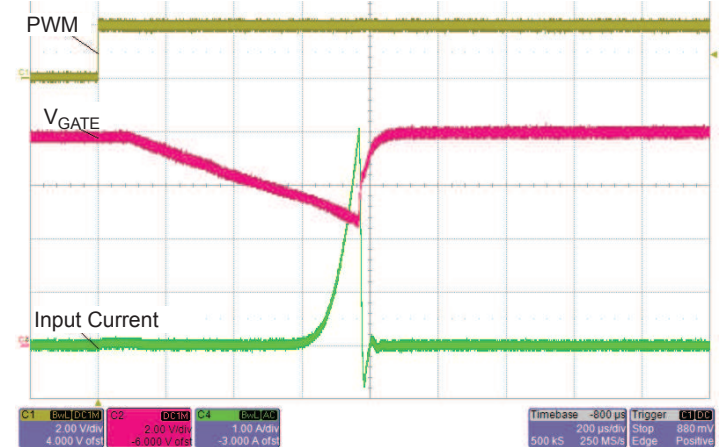

Figure 33: Startup into Output Shorted to GND fault. Input OCP tripped at 4 A ($R_{SC} = 0.024 \text{ } \Omega$, $R_{adj} = 383 \text{ } \Omega$)

During startup when Q1 first turns on, an inrush current flows through Q1 into the output capacitance. If Q1 turns on too fast (due to its low gate capacitance), the inrush current may trip input OCP limit. In this case, an external gate capacitance C_G is added to slow down the turn-on transition. Typical value for C_G is around 4.7 to 22 nF. Do not make C_G too large, since it also slows down the turn-off transient during a real input OCP fault.

A8519 and A8519-1

Wide Input Voltage Range, High-Efficiency, Fault-Tolerant LED Driver

Setting the Current Sense Resistor

As shown in Figure 32:

$$V_{IN} - V_{SENSE} = V_{SC} + I_{adj} \times R_{adj}$$

or

$$I_{SC} = ((V_{IN} - V_{SENSE}) - I_{adj} \times R_{adj}) / R_{SC}$$

where V_{SC} = the voltage drop across R_{SC} . The typical threshold for the current sense is $V_{IN} - V_{SENSE} = 110$ mV when R_{adj} is 0Ω . The A8519 can have this voltage trimmed using the R_{adj} resistor. It is recommended to set trip point to be above 3.65 A to avoid conflicts with the cycle-by-cycle current limit typical threshold. A sample calculation is done below for 4.25 A of input current.

Calculated max value of sense resistor $R_{SC} = 0.11 \text{ V} / 4.25 \text{ A} = 0.0259 \Omega$.

The R_{SC} chosen is 0.024Ω , a standard value. Therefore, the voltage drop across R_{SC} is:

$$V_{SC} = 4.25 \text{ A} \times 0.024 \Omega = 0.102 \text{ V}$$

$$R_{adj} = \frac{V_{SENSE(trip)} - V_{SC}}{I_{adj}}$$

$$R_{adj} = \frac{0.11 \text{ V} - 0.102 \text{ V}}{21.5 \mu\text{A}} = 372 \Omega$$

Input UVLO

When V_{IN} and V_{SENSE} rise above $V_{UVLOrise}$ threshold, the A8519 is enabled. The A8519 is disabled when V_{IN} falls below $V_{UVLOfall}$ threshold for more than 50 μs . This small delay is used to avoid shutting down because of momentary glitches in the input power supply.

Figure 34 illustrates a shutdown due to a falling input voltage (V_{IN}). When V_{IN} falls below 3.90 V, the IC will shut down.

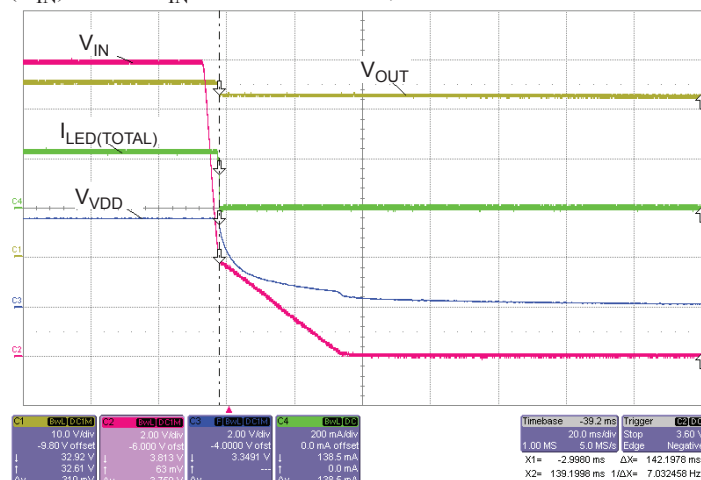

Figure 34: Shutdown with Falling Input Voltage

VDD

The VDD pin provides regulated bias supply for internal circuits. Connect a capacitor with a value of 1 μF or greater to this pin. The internal LDO can deliver no more than 2 mA of current with a typical VDD voltage of about 3.5 V, enabling this pin to serve as the pull-up voltage for the fault pin.

Shutdown

If PWM pin is pulled low for more than t_{PWML} (32,750 clock cycles), the device enters shutdown mode and clears all internal fault registers. As an example, at 2 MHz clock frequency, it will take approximately 16.3 ms to shut down the IC into the low power mode. When shut down, the IC will disable all current sources and wait until the PWM goes high to re-enable the IC.

Figure 35 depicts the shutdown using the PWM enable, showing the 16.3 ms delay between PWM signal and when the VDD and GATE of disconnect switch turn off.

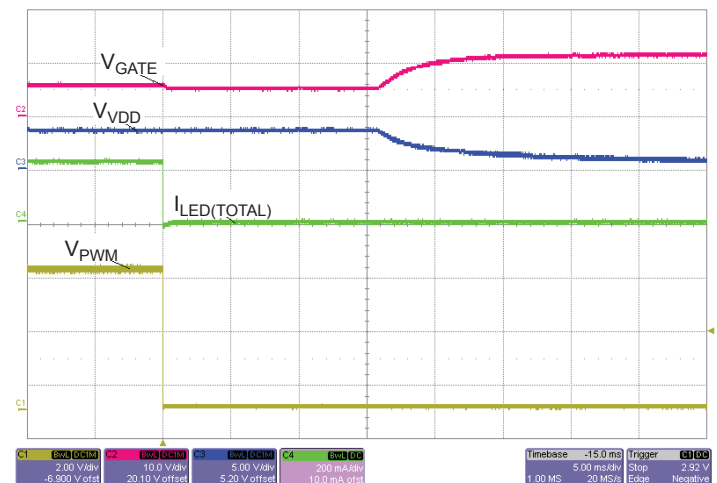

Figure 35: Shutdown Using the PWM Enable

Dithering Feature

To minimize the switching frequency harmonics, a dithering feature is implemented in A8519. This feature simplifies the input filters needed to meet the automotive CISPR 25 conducted and radiated emission limits. The dithering sweep is internally set at $\pm 5\%$. The switching frequency will ramp from 0.95 times the programmed frequency to 1.05 times the programmed frequency. The rate of modulation at which the frequency sweeps is governed by an internal 12.5 kHz triangle pattern.

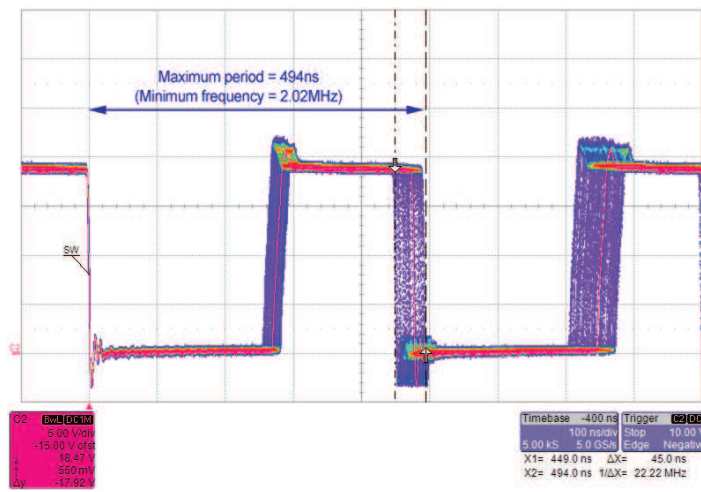

Figure 36: Minimum Dithering Switching Frequency = 2.02 MHz at $V_{IN} = 12\text{ V}$, and PWM Ratio = 100%

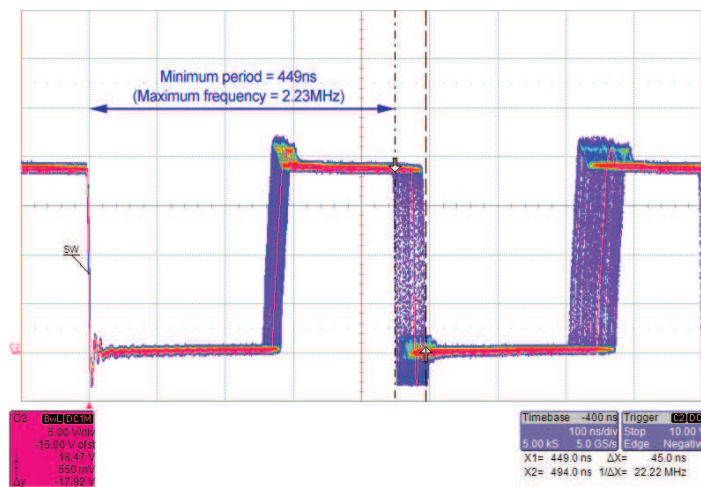

Figure 37: Maximum Dithering Switching Frequency = 2.23 MHz at $V_{IN} = 12\text{ V}$, and PWM Ratio = 100%

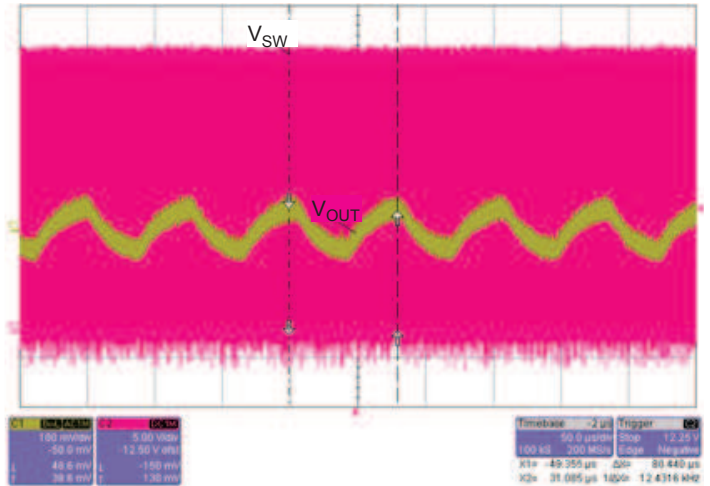

Figure 38: Output Voltage Ripple Frequency Due to Dithering = 12.4 kHz at $V_{IN} = 12\text{ V}$, and PWM Ratio = 100%

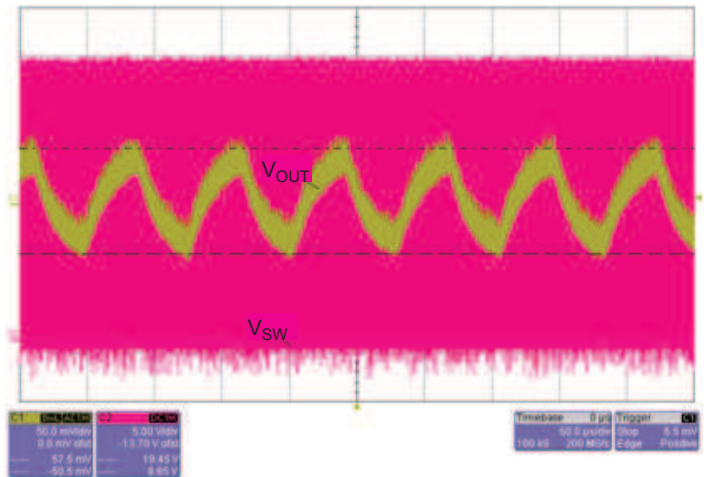

Figure 39: Output Voltage Ripple Amplitude Due to Dithering = 100 mV at $V_{IN} = 12\text{ V}$, and PWM Ratio = 100%

Fault Protection During Operation

The A8519 series devices constantly monitor the state of the system to determine if any fault conditions occur during normal operation. The response to a triggered fault condition is summarized in the table below. There are several points at which the A8519 monitors for faults during operation. The locations are input current, switch current, output voltage, switch voltage, and LED pins. (Note: Some protection features might not be active during startup to prevent false triggering of fault conditions.)

The detectable fault conditions are:

- Open LED pin
- Shorted LED pin to GND
- Open or shorted inductor
- Open or shorted boost diode
- Shorted inductor
- V_{OUT} short to GND
- SW pin shorted to GND
- ISET pin shorted to GND
- Input disconnect switch source shorted to GND

Note: Some faults will not be protected if the input disconnect switch is not used. An example of this is V_{OUT} short to GND.