



Chipsmall Limited consists of a professional team with an average of over 10 year of expertise in the distribution of electronic components. Based in Hongkong, we have already established firm and mutual-benefit business relationships with customers from,Europe,America and south Asia,supplying obsolete and hard-to-find components to meet their specific needs.

With the principle of “Quality Parts,Customers Priority,Honest Operation,and Considerate Service”,our business mainly focus on the distribution of electronic components. Line cards we deal with include Microchip,ALPS,ROHM,Xilinx,Pulse,ON,Everlight and Freescale. Main products comprise IC,Modules,Potentiometer,IC Socket,Relay,Connector.Our parts cover such applications as commercial,industrial, and automotives areas.

We are looking forward to setting up business relationship with you and hope to provide you with the best service and solution. Let us make a better world for our industry!



Contact us

Tel: +86-755-8981 8866 Fax: +86-755-8427 6832

Email & Skype: info@chipsmall.com Web: www.chipsmall.com

Address: A1208, Overseas Decoration Building, #122 Zhenhua RD., Futian, Shenzhen, China





[Home](#) / [Products](#) / [Part Numbers](#) / A8737 and A8738

A8737 and A8738 Xenon Photoflash Drivers with Fixed IGBT Gate Driver

Data sheet

- [Contact Allegro Marketing](#)

Features

- Primary side sense technology
- Fixed IGBT Drive Voltage (3 V or 5 V)
- 3 × 3 10 pin TDFN package

Applications

- Cell phone camera modules

Description

The Allegro® A8737 and A8738 Xenon photoflash charger ICs are designed to meet the needs of ultra-low power, small form factor cameras, particularly camera-phones.

These devices integrate a fixed regulator to precisely control the IGBT flash current over a wide range of battery voltages. The A8737 provides regulated 5 V, and the A8738 provides 3 V, gate drive. The IGBT driver also has separate source and sink connections, for flexibility in controlling IGBT rise and fall times.

The charge current time is adjustable by setting the charge current limit from 0.4 to 0.9 A maximum. By using primary side voltage sensing, the need for a secondary-side resistive voltage divider is eliminated. This has the additional benefit of reducing leakage currents on the secondary side of the transformer. To extend battery life, the A8737 and A8738 feature very low supply current draw-typically 0.5 μ A maximum in shutdown mode.

The charge and trigger voltage logic thresholds are set at 1.1 VHI(min) to support applications implementing low voltage control logic.

The devices are available in a 10-contact, 3 mm × 3 mm MLP/TDFN package with exposed pad for enhanced thermal performance. It is lead (Pb) free, with 100% matte-tin leadframe plating. For an even smaller PCB footprint, a wafer-level chip scale package (WLCSPP) option is available (contact factory for availability).

Functional Block Diagram

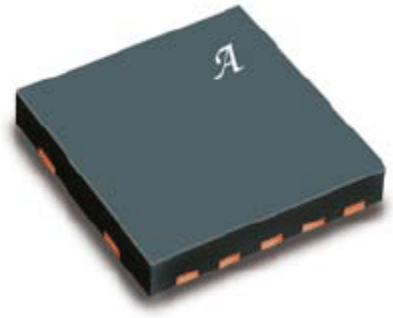

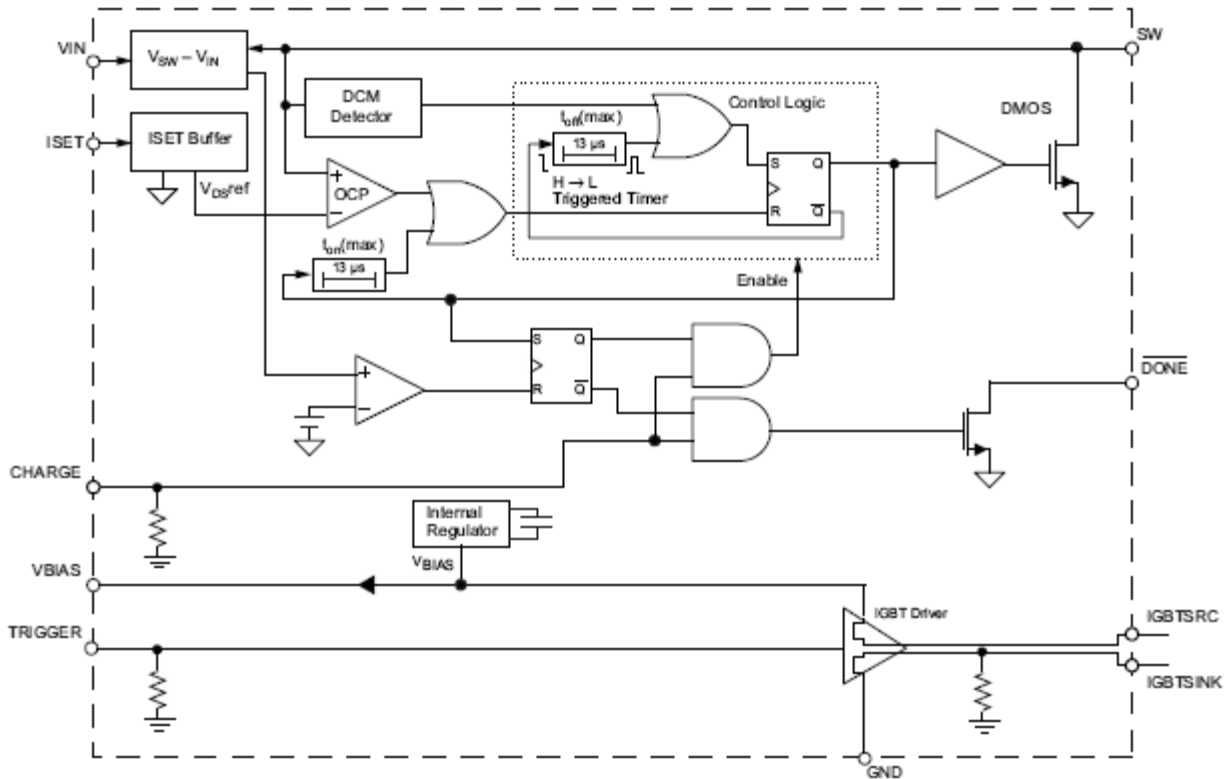

Complete Part Numbers

Part Number	Package Type	RoHS Compliant	Part Composition/ RoHS Data	Temperature	Comments	Samples	Distributor Stock
A8737EEJTR-T	10-lead MLP	Yes	view data	-40 °C to 85 °C	<i>new</i>	Contact Local Sales Representative or check distributor stock	<input type="button" value="Check Stock"/>
A8738EEJTR-T	10-lead MLP	Yes	view data	-40 °C to 85 °C	<i>new</i>	Contact Local Sales Representative or check distributor stock	<input type="button" value="Check Stock"/>

Allegro's products are not to be used in life support devices or systems, if a failure of an Allegro product can reasonably be expected to cause the failure of that life support device or system, or to affect the safety or effectiveness of that device or system.

Copyright © 2009 Allegro MicroSystems, Inc. • 115 Northeast Cutoff, Worcester, MA 01606 USA • Phone: 1.508.853.5000 • Fax: 1.508.853.7895