



Chipsmall Limited consists of a professional team with an average of over 10 year of expertise in the distribution of electronic components. Based in Hongkong, we have already established firm and mutual-benefit business relationships with customers from,Europe,America and south Asia,supplying obsolete and hard-to-find components to meet their specific needs.

With the principle of “Quality Parts,Customers Priority,Honest Operation,and Considerate Service”,our business mainly focus on the distribution of electronic components. Line cards we deal with include Microchip,ALPS,ROHM,Xilinx,Pulse,ON,Everlight and Freescale. Main products comprise IC,Modules,Potentiometer,IC Socket,Relay,Connector.Our parts cover such applications as commercial,industrial, and automotives areas.

We are looking forward to setting up business relationship with you and hope to provide you with the best service and solution. Let us make a better world for our industry!



## Contact us

Tel: +86-755-8981 8866 Fax: +86-755-8427 6832

Email & Skype: info@chipsmall.com Web: www.chipsmall.com

Address: A1208, Overseas Decoration Building, #122 Zhenhua RD., Futian, Shenzhen, China



Part Number: AAD1-9090SE9ZC/2

Reddish-Orange



**ATTENTION**  
OBSERVE PRECAUTIONS  
FOR HANDLING  
ELECTROSTATIC  
DISCHARGE  
SENSITIVE  
DEVICES

## Features

- Super high flux output and high luminance.
- Designed for high current operation.
- Low thermal resistance.
- Low voltage DC operated.
- Superior ESD protection.
- Package: 500pcs/reel.
- Not reflow compatible.
- The component is internally protected with silicone gel.
- RoHS compliant.

## Application Note

Static electricity and surge damage the LEDs.

It is recommended to use a wrist band or anti-electrostatic glove when handling the LEDs.

All devices, equipment and machinery must be electrically grounded.



## Applications

- traffic signaling.
- backlighting (illuminated advertising , general lighting).
- interior and exterior automotive lighting.
- substitution of micro incandescent lamps.
- portable light source (e.g. bicycle flashlight).
- signal and symbol luminaire for orientation.
- marker lights (e.g. steps, exit ways, etc).
- decorative and entertainment lighting.
- indoor and outdoor commercial and residential architectural lighting.

## Package Dimensions

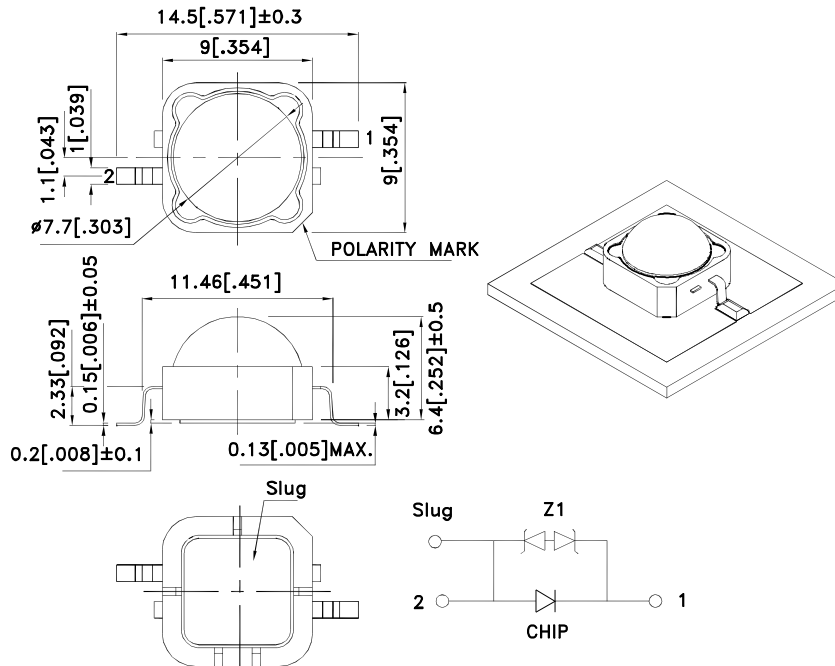

### Notes:

1. All dimensions are in millimeters (inches).
2. Tolerance is ±0.25(0.01") unless otherwise noted.
3. The specifications, characteristics and technical data described in the datasheet are subject to change without prior notice.
4. The device has a single mounting surface. The device must be mounted according to the specifications.



## Handling Precautions

Compare to epoxy encapsulant that is hard and brittle, silicone is softer and flexible. Although its characteristic significantly reduces thermal stress, it is more susceptible to damage by external mechanical force.

As a result, special handling precautions need to be observed during assembly using silicone encapsulated LED products. Failure to comply might lead to damage and premature failure of the LED.

1. Handle the component along the side surfaces by using forceps or appropriate tools.

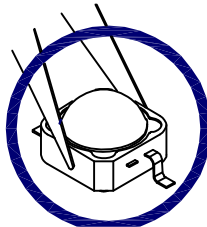

2. Do not directly touch or handle the silicone lens surface. It may damage the internal circuitry.

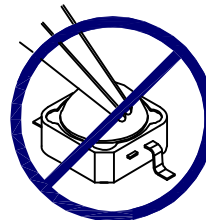
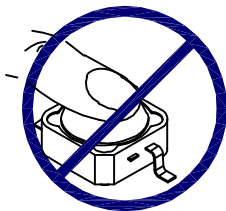

3. Do not stack together assembled PCBs containing exposed LEDs. Impact may scratch the silicone lens or damage the internal circuitry.

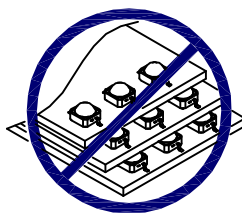

- 4.1. The outer diameter of the SMD pickup nozzle should not exceed the size of the LED to prevent air leaks. The inner diameter of the nozzle should be as large as possible.

- 4.2. A pliable material is suggested for the nozzle tip to avoid scratching or damaging the LED surface during pickup.

- 4.3. The dimensions of the component must be accurately programmed in the pick-and-place machine to insure precise pickup and avoid damage during production.

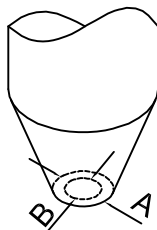

5. As silicone encapsulation is permeable to gases, some corrosive substances such as  $H_2S$  might corrode silver plating of leadframe. Special care should be taken if an LED with silicone encapsulation is to be used near such substances.



## Selection Guide

Part No.	Dice	Lens Type	luminous Intensity Iv (cd)@ 500 mA [2]		Φv (lm) @ 500 mA [2]		Viewing Angle [1]
			Min.	Typ.	Min.	Typ.	2θ1/2
AAD1-9090SE9ZC/2	REDDISH-ORANGE (AlGaInP)	Water Clear	12	20	35	50	100°

Notes:

1. θ1/2 is the angle from optical centerline where the luminous intensity is 1/2 of the optical peak value.
2. Luminous intensity/ luminous Flux: +/-15%.

## Absolute Maximum Ratings at TA=25°C

Parameter	Symbol	Value	Unit
Power dissipation	PD	1.65	W
Junction temperature	TJ	110	°C
Reverse Voltage	VR	5	V
Operating Temperature	Top	-40 To +100	°C
Storage Temperature	Tstg	-40 To +100	°C
DC Forward Current [1]	IF	500	mA
Peak Forward Current [2]	IFM	700	mA
Thermal resistance [1]	Rth j-slug	12	°C/W
Electrostatic Discharge Threshold (HBM)		8000	V
Iron Soldering [3]		350°C For 3 Seconds	

Notes:

1. Results from mounting on MCPCB.
2. 1/10 Duty Cycle, 0.1ms Pulse Width.
3. 1.29mm distance from solder joint to package.

## Electrical / Optical Characteristics at TA=25°C

Parameter	Symbol	Value	Unit
Wavelength at peak emission IF=500mA [Typ.]	λpeak	635	nm
Dominant Wavelength IF=500mA [Typ.]	λ dom [1]	623	nm
Spectral bandwidth at 50%ΦREL MAX IF=500mA [Typ.]	Δλ	22	nm
Allowable Reverse Current [Max.]	IR	85	mA
Forward Voltage IF=500mA [Min.]	VF [2]	-	V
Forward Voltage IF=500mA [Typ.]		2.7	
Forward Voltage IF=500mA [Max.]		3.3	
Temperature coefficient of λpeak IF=500mA, -10°C ≤ T ≤ 100°C [Typ.]	TCλpeak	0.08	nm/°C
Temperature coefficient of λ.dom IF=500mA, -10°C ≤ T ≤ 100°C [Typ.]	TCλ.dom	0.03	nm/°C
Temperature coefficient of VF IF=500mA, -10°C ≤ T ≤ 100°C [Typ.]	TCV	-2.8	mV/°C

Notes:

1. Wavelength: +/-1nm.
2. Forward Voltage: +/-0.1V.

# Kingbright

## AAD1-9090SE9ZC/2

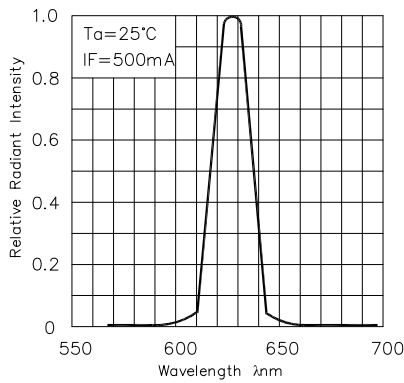

RELATIVE INTENSITY Vs. WAVELENGTH

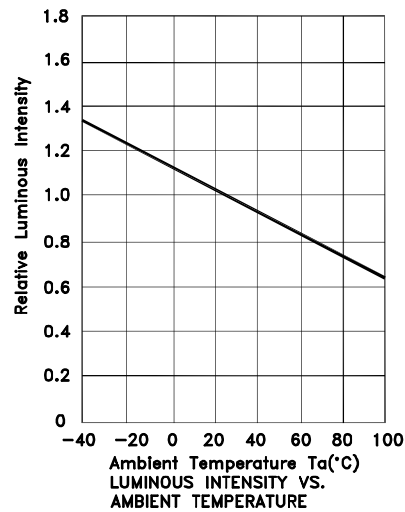
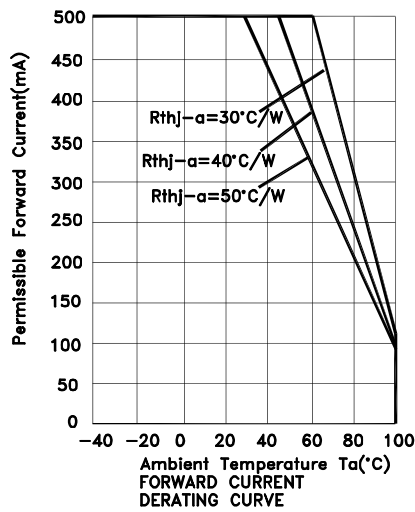
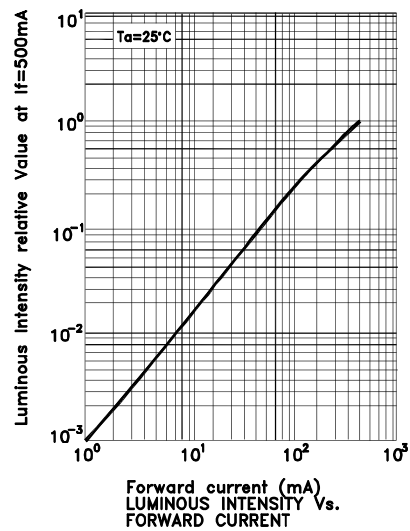
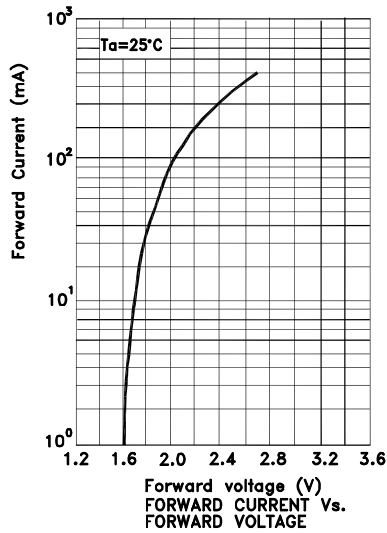
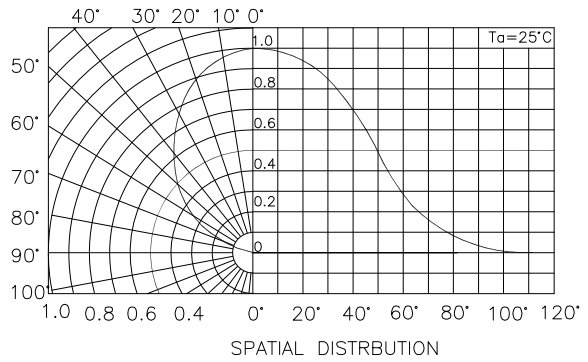

**AAD1-9090SE9ZC/2**  
**Recommended Soldering Pattern**  
 (Units : mm; Tolerance:  $\pm 0.1$ )

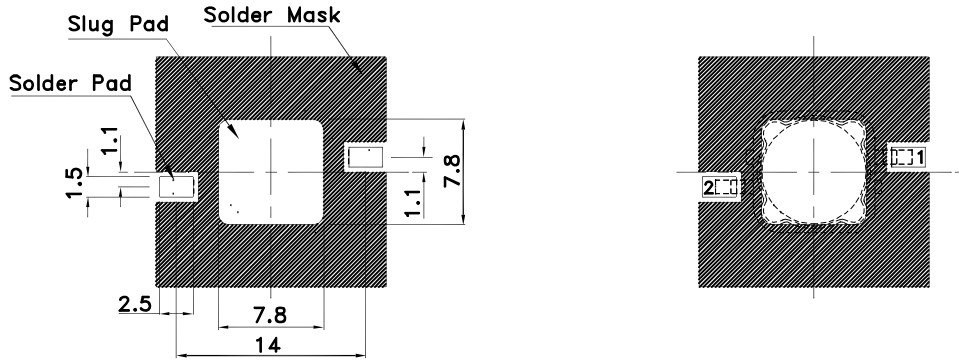

**Reel Dimension**

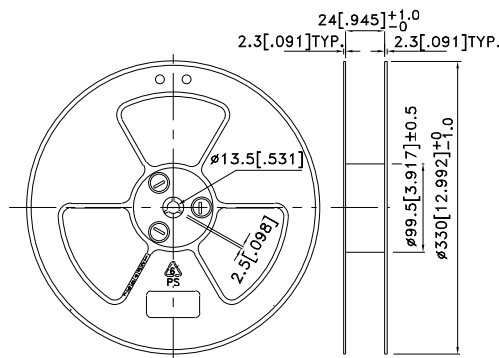

**Tape Specifications**  
 (Units : mm)

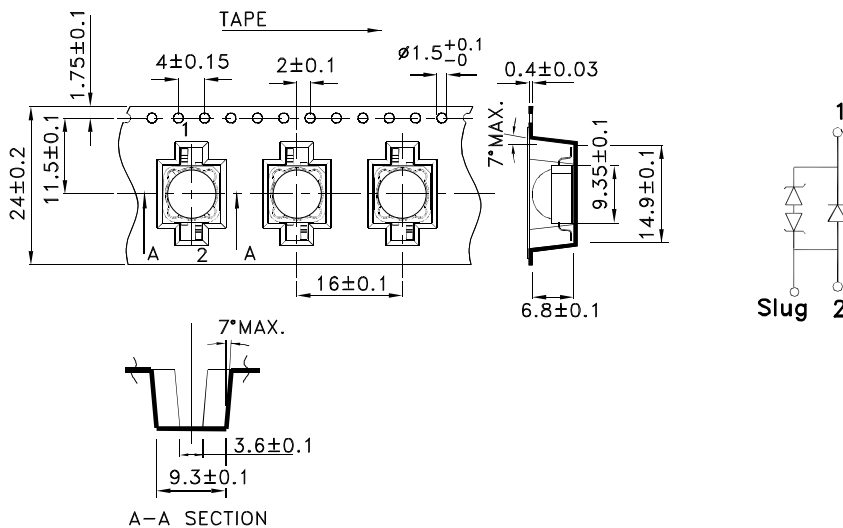

## AAD1-9090SE9ZC/2

### Recommended Solder Steps

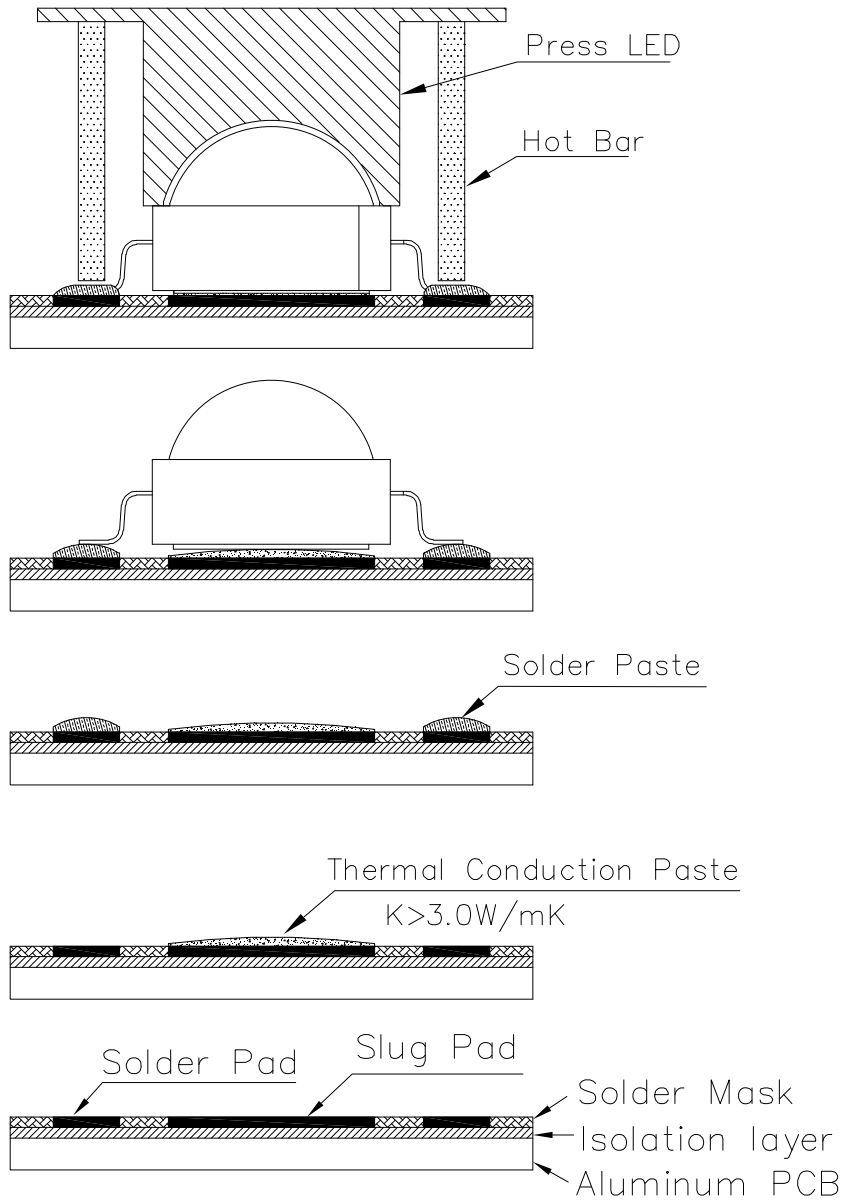

**PACKING & LABEL SPECIFICATIONS**

**AAD1-9090SE9ZC/2**

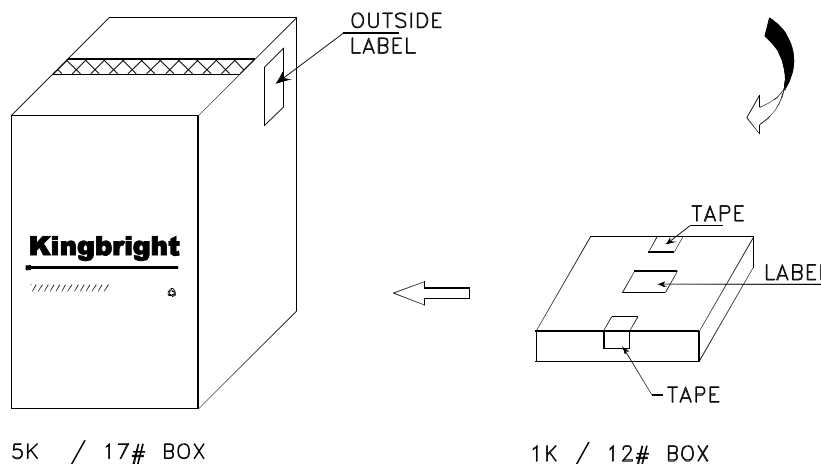
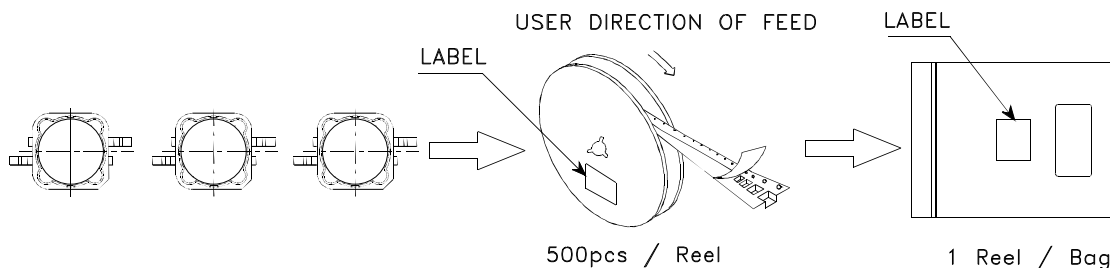

<h2 style="margin: 0;">Kingbright</h2>	
P/NO: AAD1-9090xxx	
QTY: 500 pcs	Q.C. <span style="border: 1px solid black; border-radius: 50%; padding: 2px;">Q C XX XX XXXX PASSED</span>
S/N: XXXX	
CODE: XXX	
LOT NO:	
XXXXXXXXXXXXXXXXXXXXXXXXXXXX	
RoHS Compliant	