



Chipsmall Limited consists of a professional team with an average of over 10 year of expertise in the distribution of electronic components. Based in Hongkong, we have already established firm and mutual-benefit business relationships with customers from,Europe,America and south Asia,supplying obsolete and hard-to-find components to meet their specific needs.

With the principle of “Quality Parts,Customers Priority,Honest Operation,and Considerate Service”,our business mainly focus on the distribution of electronic components. Line cards we deal with include Microchip,ALPS,ROHM,Xilinx,Pulse,ON,Everlight and Freescale. Main products comprise IC,Modules,Potentiometer,IC Socket,Relay,Connector.Our parts cover such applications as commercial,industrial, and automotives areas.

We are looking forward to setting up business relationship with you and hope to provide you with the best service and solution. Let us make a better world for our industry!



Contact us

Tel: +86-755-8981 8866 Fax: +86-755-8427 6832

Email & Skype: info@chipsmall.com Web: www.chipsmall.com

Address: A1208, Overseas Decoration Building, #122 Zhenhua RD., Futian, Shenzhen, China



AAK001-14E High-Field Magnetic Sensor

Schematic Diagram

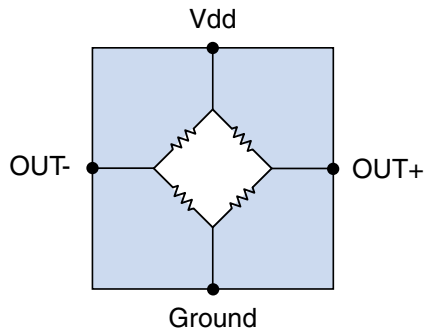

Features

- Precise sensing of magnetic fields up to 4 kOe (400 mT)
- Sensitive to fields of any direction in the IC plane
- Ratiometric Wheatstone bridge outputs
- Any operating supply voltage up to 12V
- Ultraminiature 1.1 x 1.1 mm package

Applications

- Brushless DC motors
- Motor commutator sensors
- Noncontact high-current measurement
- Harsh industrial applications

Magnetic Response

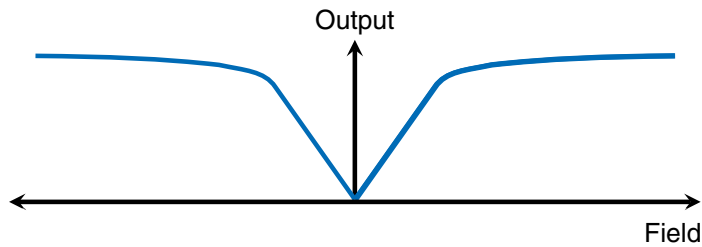

Description

The AAK001-14E is a high-field magnetometer sensor that provides precise sensing of magnetic fields up to 4 kOe (400 mT). NVE's proprietary Giant Magnetoresistive (GMR) technology provides precision over a wide field range without the complications of shielding.

The sensors respond from zero field to 4 kOe (400 mT), and are highly linear from 400 Oe (40 mT) to 2.5 kOe (250 mT).

The sensor is configured as a Wheatstone bridge with two element types—one to sense the field and the other for temperature compensation.

The sensor element is not directionally sensitive in the IC plane, so output from the sensor element is the same regardless of the direction of the applied magnetic field. As the direction of the applied field moves out of the plane of the IC, the sensor output is roughly proportional to the cosine of the angle between the applied field and the IC.

Absolute Maximum Ratings

Parameter	Min.	Max.	Units
Supply voltage		30	Volts
Storage temperature	-65	135	°C
Junction temperature	-65	135	°C
Applied magnetic field		Unlimited	

Operating Specifications

Specifications valid overall operating voltage and temperature ranges unless otherwise noted.						
Parameter	Symbol	Min.	Typ.	Max.	Units	Test Conditions
Supply voltage	V_{DD}	<1		12.6	Volts	
Operating temperature	$T_{MIN}; T_{MAX}$	-40		85	°C	
Saturation field	H_{SAT}		4000		Oe	
Linear range	H_{LIN}	400		2500	Oe	
Sensitivity	$\Delta V_{OUT}/\Delta H$		3.3		$\mu V/V/Oe$	
Device resistance	R_{DEVICE}	2.8	3.5	4.2	k Ω	$T_A = 25^\circ C$
Electrical offset	V_O	-4		4	mV/V	
Maximum output	$V_{OUT-MAX}$	19	25		mV/V	$T_A = 25^\circ C$
Operating frequency	$f_{MIN}; f_{MAX}$	DC		50	kHz	
Nonlinearity				2	%	Unipolar field sweep
Hysteresis				4		
Resistance vs. temperature	TC_R		+0.1		%/°C	
Output temperature coefficient	TC_{O-I}		-0.13			Constant current supply
	TC_{O-V}		-0.3			Constant voltage supply
Saturation field temperature coefficient	TC_{HSAT}		-0.19			

Thermal Characteristics

Parameter	Symbol	Min.	Typ.	Max.	Units	Test Conditions
Junction–Ambient Thermal Resistance	θ_{JA}		500		°C/W	Soldered to double-sided board
Power Dissipation	P_D			100	mW	

Operation

Unlike Hall effect or other sensors, the direction of sensitivity is in the plane of the package. The diagrams below show two permanent magnet orientations that will activate the sensor in the direction of sensitivity:

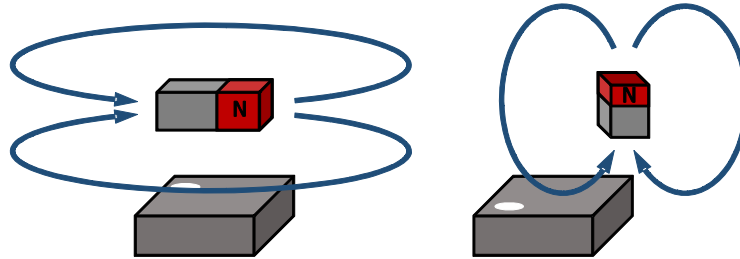

Figure 1. Planar magnetic sensitivity.

The sensor element is not directionally sensitive in the IC plane, so output from the sensor element is the same regardless of the direction of the applied magnetic field. Out of the IC plane, the output is roughly proportional to the cosine of the angle between the applied field and the IC.

Typical Performance

As shown in Figure 2, the AK001 respond from zero field to 4 kOe, and are highly linear from 400 Oe to 2.5 kOe. The saturation field is dependant on temperature, but sensitivity is quite stable with temperature.

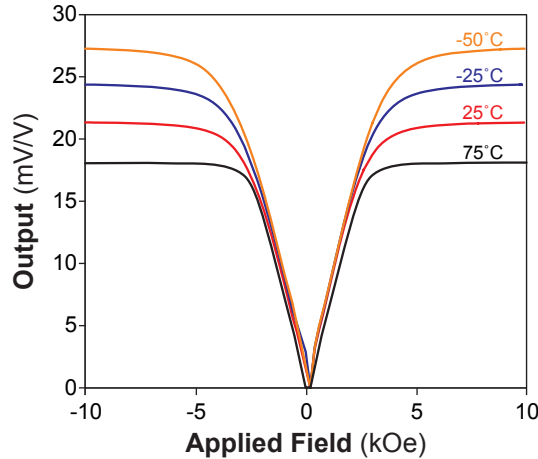

Figure 2. Output versus temperature.

Typical Applications

Traditional Differential Amplifier

Traditional differential amplifiers use low-cost op-amps to provide a single-ended analog output. The circuit below has a gain of 30, which provides a full-scale output at slightly less than the sensor’s saturation. A low-cost, low bias current op amp allows large resistors to avoid loading the sensor bridge. The 200 KΩ input resistors are more than 100 times the 1.75 KΩ typical sensor output impedance to avoid loading.

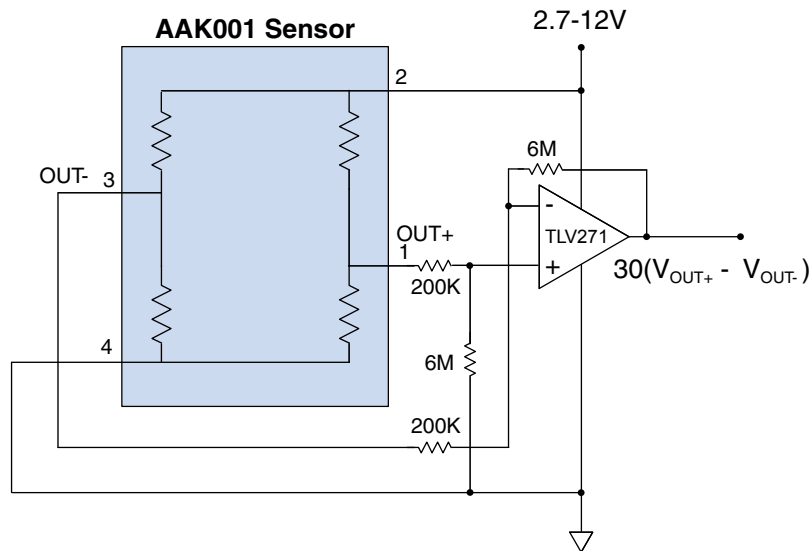

Figure 3. Traditional op-amp differential amplifier.

Sensor Instrumentation Amplifier

Instrumentation amplifiers such as the INA826 are popular bridge sensor preamplifiers because they have a low component count and have excellent common-mode rejection ratios without needing to match resistors. These amplifiers can run on single or dual

supplies. AC coupling can be used for small, dynamic signals.

The circuit below provides a single-ended, amplified output with offset correction:

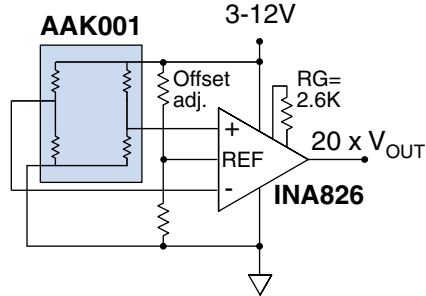

Figure 4. Single-ended analog sensor instrumentation amplifier.

The circuit has a gain of 20, which will provide full-scale output of half the power supply with the typical maximum sensor output of 20 mV/V. The general equation for the output voltage is:

$$V_{OUT} = (1 + 49.4K / R_G)V_{IN} + V_{REF}; \quad V_{IN} = V_{OUT+} - V_{OUT-}$$

Constant-Current Sensor Drive

Using a constant current rather than conventional constant voltage sensor supply can significantly improve temperature stability of the sensor. AAK001 sensors have an output temperature coefficient (TC_{O-I}) of 0.13%/°C with constant current, versus -0.3%/°C with constant voltage (TCOV).

A simple constant-current supply is illustrated below:

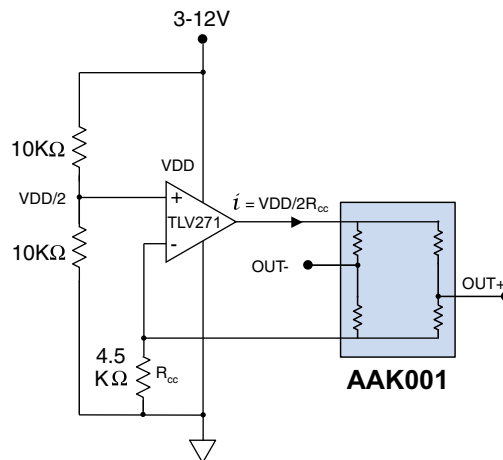

Figure 5. Constant-current supply.

The supply current for the circuit above is $V_{cc}/2R_{cc}$. R_{cc} can be set slightly more than the 4.2 KΩ maximum sensor bridge resistance to provide the highest possible output without saturating the op-amp. The circuit above will drive the sensor with 1.33 mA for a 12-volt supply.

Constant-current drive circuitry can be combined with amplifier circuitry such as that in Figure 3 or Figure 4.

Variable Threshold Magnetic Switch

AAK001 sensors can be used as high-field magnetic switches, allowing thresholds as high as 4 kOe and variable hysteresis, using a circuit such as this:

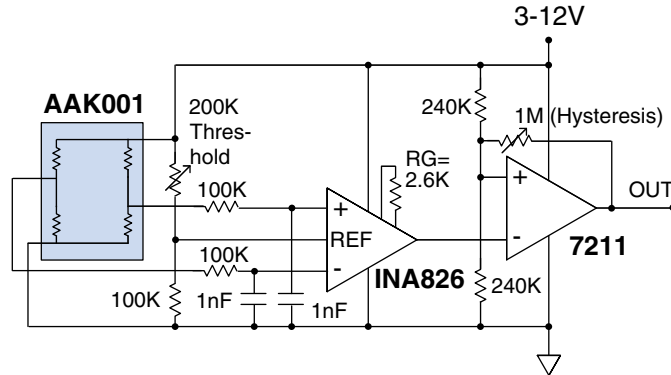

Figure 6. Variable threshold magnetic switch.

LED Field-Strength Indicator

The op-amp circuit in Figure 7 can be used to change the brightness of an LED to indicate magnetic field strength:

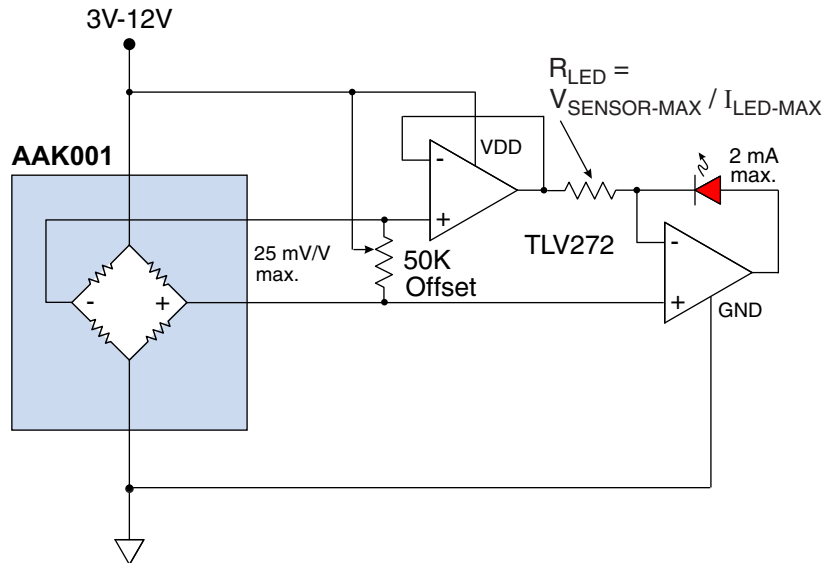

Figure 7. LED brightness changes with magnetic field.

The LED current is proportional to the sensor output:

$$I_{LED} = (V_{OUT+} - V_{OUT-}) / R_{LED}$$

The maximum LED current can be set to the maximum sensor output. For example, the typical maximum sensor output is 25 mV/V, so for a 3 volt supply the maximum is approximately 75 mV. For a high-efficiency LED, the maximum LED current is 2 mA, so $R_{LED} = 75 \text{ mV} / 2 \text{ mA} = 38\Omega$.

The 50 KΩ potentiometer can be used to correct for sensor offset or to set the minimum field to turn on the LED.

1.1 x 1.1 x 0.37 mm ULLGA Package (-14E suffix)

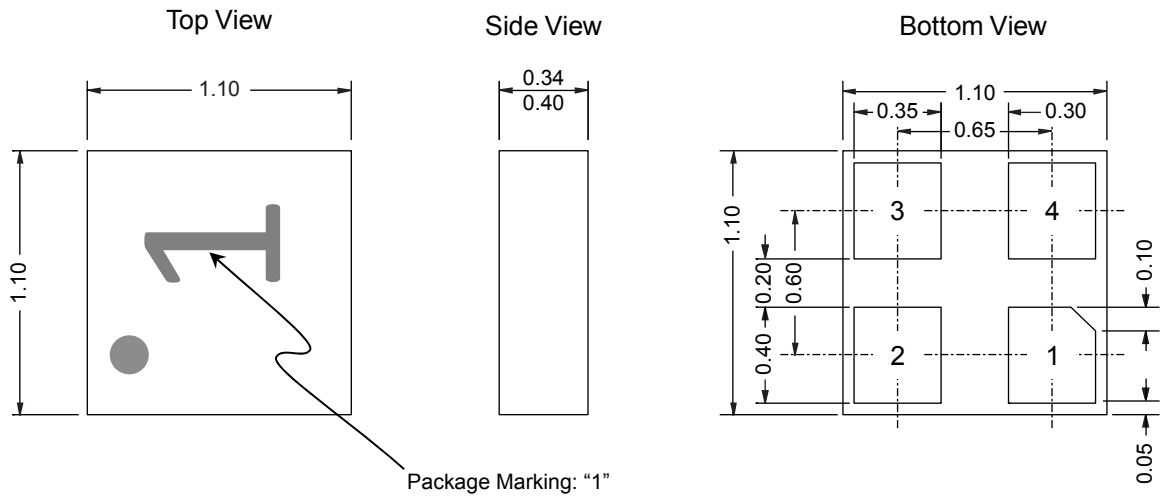

Package Marking: "1"

Dimensions in mm; ± 0.10 mm unless otherwise noted.



Pin	Function
1	Out+
2	V _{DD}
3	Out-
4	Ground

Soldering profile per JEDEC J-STD-020C, MSL 1.

This product has been tested for electrostatic sensitivity to the limits stated in the specifications. However, NVE recommends that all integrated circuits be handled with appropriate care to avoid damage. Damage caused by inappropriate handling or storage could range from performance degradation to complete failure.



Revision History

SB-00-068
August 2017

Change

- Initial Release

Datasheet Limitations

The information and data provided in datasheets shall define the specification of the product as agreed between NVE and its customer, unless NVE and customer have explicitly agreed otherwise in writing. All specifications are based on NVE test protocols. In no event however, shall an agreement be valid in which the NVE product is deemed to offer functions and qualities beyond those described in the datasheet.

Limited Warranty and Liability

Information in this document is believed to be accurate and reliable. However, NVE does not give any representations or warranties, expressed or implied, as to the accuracy or completeness of such information and shall have no liability for the consequences of use of such information.

In no event shall NVE be liable for any indirect, incidental, punitive, special or consequential damages (including, without limitation, lost profits, lost savings, business interruption, costs related to the removal or replacement of any products or rework charges) whether or not such damages are based on tort (including negligence), warranty, breach of contract or any other legal theory.

Right to Make Changes

NVE reserves the right to make changes to information published in this document including, without limitation, specifications and product descriptions at any time and without notice. This document supersedes and replaces all information supplied prior to its publication.

Use in Life-Critical or Safety-Critical Applications

Unless NVE and a customer explicitly agree otherwise in writing, NVE products are not designed, authorized or warranted to be suitable for use in life support, life-critical or safety-critical devices or equipment. NVE accepts no liability for inclusion or use of NVE products in such applications and such inclusion or use is at the customer's own risk. Should the customer use NVE products for such application whether authorized by NVE or not, the customer shall indemnify and hold NVE harmless against all claims and damages.

Applications

Applications described in this datasheet are illustrative only. NVE makes no representation or warranty that such applications will be suitable for the specified use without further testing or modification.

Customers are responsible for the design and operation of their applications and products using NVE products, and NVE accepts no liability for any assistance with applications or customer product design. It is customer's sole responsibility to determine whether the NVE product is suitable and fit for the customer's applications and products planned, as well as for the planned application and use of customer's third party customers. Customers should provide appropriate design and operating safeguards to minimize the risks associated with their applications and products.

NVE does not accept any liability related to any default, damage, costs or problem which is based on any weakness or default in the customer's applications or products, or the application or use by customer's third party customers. The customer is responsible for all necessary testing for the customer's applications and products using NVE products in order to avoid a default of the applications and the products or of the application or use by customer's third party customers. NVE accepts no liability in this respect.

Limiting Values

Stress above one or more limiting values (as defined in the Absolute Maximum Ratings System of IEC 60134) will cause permanent damage to the device. Limiting values are stress ratings only and operation of the device at these or any other conditions above those given in the recommended operating conditions of the datasheet is not warranted. Constant or repeated exposure to limiting values will permanently and irreversibly affect the quality and reliability of the device.

Terms and Conditions of Sale

In case an individual agreement is concluded only the terms and conditions of the respective agreement shall apply. NVE hereby expressly objects to applying the customer's general terms and conditions with regard to the purchase of NVE products by customer.

No Offer to Sell or License

Nothing in this document may be interpreted or construed as an offer to sell products that is open for acceptance or the grant, conveyance or implication of any license under any copyrights, patents or other industrial or intellectual property rights.

Export Control

This document as well as the items described herein may be subject to export control regulations. Export might require a prior authorization from national authorities.

Automotive Qualified Products

Unless the datasheet expressly states that a specific NVE product is automotive qualified, the product is not suitable for automotive use. It is neither qualified nor tested in accordance with automotive testing or application requirements. NVE accepts no liability for inclusion or use of non-automotive qualified products in automotive equipment or applications.

In the event that customer uses the product for design-in and use in automotive applications to automotive specifications and standards, customer (a) shall use the product without NVE's warranty of the product for such automotive applications, use and specifications, and (b) whenever customer uses the product for automotive applications beyond NVE's specifications such use shall be solely at customer's own risk, and (c) customer fully indemnifies NVE for any liability, damages or failed product claims resulting from customer design and use of the product for automotive applications beyond NVE's standard warranty and NVE's product specifications.

An ISO 9001 Certified Company

NVE Corporation
11409 Valley View Road
Eden Prairie, MN 55344-3617 USA
Telephone: (952) 829-9217
Fax: (952) 829-9189
www.nve.com
e-mail: sensor-info@nve.com

©NVE Corporation
All rights are reserved. Reproduction in whole or in part is prohibited without the prior written consent of the copyright owner.

SB-00-068

August 2017