



Chipsmall Limited consists of a professional team with an average of over 10 year of expertise in the distribution of electronic components. Based in Hongkong, we have already established firm and mutual-benefit business relationships with customers from,Europe,America and south Asia,supplying obsolete and hard-to-find components to meet their specific needs.

With the principle of “Quality Parts,Customers Priority,Honest Operation,and Considerate Service”,our business mainly focus on the distribution of electronic components. Line cards we deal with include Microchip,ALPS,ROHM,Xilinx,Pulse,ON,Everlight and Freescale. Main products comprise IC,Modules,Potentiometer,IC Socket,Relay,Connector.Our parts cover such applications as commercial,industrial, and automotives areas.

We are looking forward to setting up business relationship with you and hope to provide you with the best service and solution. Let us make a better world for our industry!



Contact us

Tel: +86-755-8981 8866 Fax: +86-755-8427 6832

Email & Skype: info@chipsmall.com Web: www.chipsmall.com

Address: A1208, Overseas Decoration Building, #122 Zhenhua RD., Futian, Shenzhen, China



AAT101 Full-Bridge TMR Angle Sensor

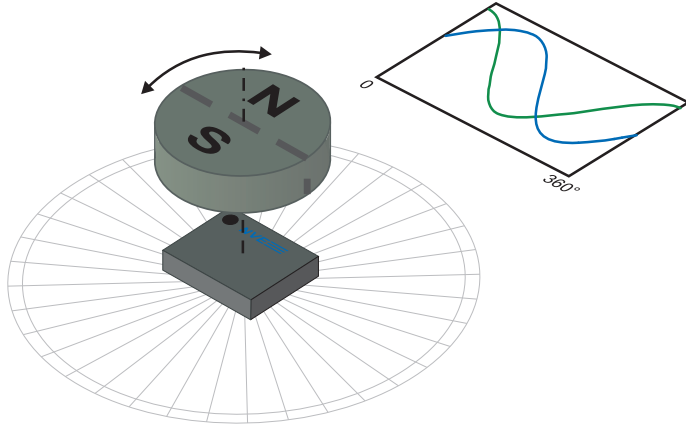

Features

- Tunneling Magnetoresistance (TMR) technology
- Extremely low power (as low as sub microamps)
- Full-bridge (differential) configuration
- High output signal without amplification
- Immune to airgap variations
- Operates with as little as 30 Oersted field
- Sine and cosine and outputs
- -40°C to $+125^{\circ}\text{C}$ operating temperature
- Ultraminiature TDFN6 packages

Applications

- Battery-powered applications
- Knob position sensors
- Rotary encoders
- Automotive rotary position sensors
- Motor shaft position sensors

Description

AAT-Series angle sensors use unique Tunneling Magnetoresistance (TMR) elements for large signals and low power consumption.

The AAT101 is a full-bridge version of NVE's ground-breaking half-bridge angle AAT001 sensors. The full-bridge configuration provides two differential outputs for easier interface in certain applications, twice as much signal, and less supply voltage or temperature dependence.

The sensors provide sine and cosine signals defining the angle of rotation. Outputs are proportional to the supply voltage and peak-to-peak output voltages are much larger than conventional sensor technologies.

The typical device resistance of $625\text{ k}\Omega$ enables low power, and is ideal for battery-powered applications.

Parts are packaged in NVE's $2.5\text{ mm} \times 2.5\text{ mm} \times 0.8\text{ mm}$ TDFN6 surface-mount package.

Functional Diagram

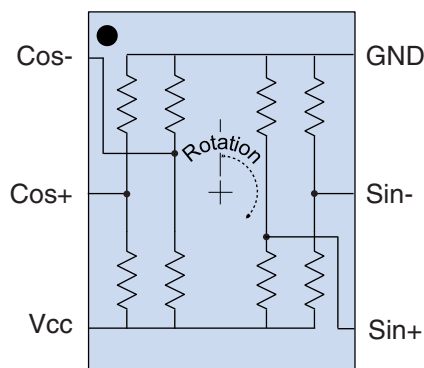

Absolute Maximum Ratings

Parameter	Min.	Max.	Units
Supply voltage		7	Volts
Reverse supply voltage		-1	Volt
Storage temperature	-40	170	°C
ESD (Human Body Model)		2000	Volts
Applied magnetic field		Unlimited ¹	Oe

Operating Specifications

Parameter	Symbol	Min.	Typ.	Max.	Units	Test Condition
Operating temperature	$T_{min}; T_{max}$	-40		125	°C	
Device resistance		0.5	0.625	2	MΩ	25°C with required magnetic field.
Peak-to-peak output signal	V_{PP-SIN} V_{PP-COS}	260	400		mV/V	Over full rotation.
Offset voltage	$V_{OFFSET-SIN}$ $V_{OFFSET-COS}$	-10		+10	mV/V	
Supply voltage	V_{CC}	0		5.5	V	
Required applied magnetic field		30		200	Oe	
Repeatability, fixed bias ²				±0.5	deg.	
Repeatability, variable bias ³				±3	deg.	
Nonsinusoidality ⁴			±1.5%			% of peak-to-peak output; 50 Oe applied field; 25°C
Temperature coefficient of resistance	TCOR		+0.09		%/°C	
Output voltage temperature coefficient	TCOV		-0.13		%/°C	Constant supply voltage.

Notes:

1. Large magnetic fields CANNOT damage NVE sensors.
2. “Fixed Bias” means a fixed airgap between the bias magnet and sensor so the magnetic field at the sensor is constant.
3. “Variable Bias” means the magnetic field strength at the sensor can vary across the specification range.
4. Maximum deviation of either output from an ideal sine wave.

Operation

Overview—Unique TMR technology

The heart of the unique sensor is an array of four Tunneling Magnetoresistance (TMR) elements in each quadrant. TMR technology enables low power and miniaturization, making the sensors ideal for battery operation.

In a typical configuration, an external magnet provides a saturating magnetic field in the plane of the sensor, as illustrated below for a bar magnet and a radially-magnetized disk magnet:

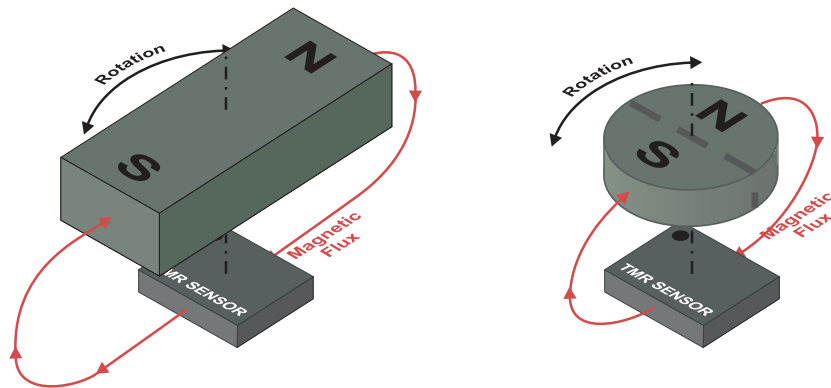

Figure 1. Sensor operation.

The device contains four sensing resistors at 90 degree intervals. The resistors are connected as two half-bridges, providing the sine and cosine voltage outputs. For each half bridge, the resistance of one element increases and the other decreases as the field rotates. Thus the bridge resistances, device resistance, and output impedances remain constant with rotation.

Transfer function

Full-bridge devices (AAT10x) provide two differential outputs for twice the signal and inherent temperature and supply voltage compensation. This configuration can also be used for drop-in upgrade of AMR sensor designs. Mathematically, the outputs are:

$$V_{\text{SIN}} = V_{\text{CC}} [V_{\text{SIN-MAX}} - V_{\text{SIN-MIN}}] / 2 \text{ Sin } \theta + V_{\text{OFFSET-SIN}}$$

$$V_{\text{COS}} = V_{\text{CC}} [V_{\text{COS-MAX}} - V_{\text{COS-MIN}}] / 2 \text{ Cos } \theta + V_{\text{OFFSET-COS}}$$

Where:

θ is the magnetic field angle;

V_{CC} is the supply voltage;

V_{COS} and V_{SIN} are the differential sensor output voltages ($V_{\text{COS+}} - V_{\text{COS-}}$ and $V_{\text{SIN+}} - V_{\text{SIN-}}$ in mV/V);

$V_{\text{SIN-MAX}}$, $V_{\text{COS-MAX}}$, $V_{\text{SIN-MIN}}$, and $V_{\text{COS-MIN}}$ are the peak differential sensor output signal levels (mV/V); and

$V_{\text{OFFSET-SIN}}$ and $V_{\text{OFFSET-COS}}$ are the sensor offset voltages (mV/V), defined as $(V_{\text{SIN-MAX}} + V_{\text{SIN-MIN}}) / 2$, and $(V_{\text{COS-MAX}} + V_{\text{COS-MIN}}) / 2$.

The sensors operate with fields from 30 Oe to 200 Oe. This wide magnetic field range allows inexpensive magnets and operation over a wide range of magnet spacing. Larger or stronger magnets require more distance to avoid oversaturating the sensor; smaller or weaker magnets may require closer spacing. Low-cost radially-magnetized ferrite disk magnets can be used with these sensors in production. Bar magnets are also used in some configurations.

Ideal for battery and harvested power

AAT-Series sensors are resistive devices with no active components, so they have no minimum voltage and can be powered from single cells. With their low power, the sensors are well-suited for operation from batteries or harvested power, and can run continuously for many years on small alkaline, silver oxide, or lithium button cells.

One cycle per revolution

Other sensor types such as AMR have two cycles per revolution, so they cannot determine absolute position for 360-degree rotation. AAT-Series sensors output one cycle per revolution and can unambiguously determine position within a full rotation.

Detects absolute position

Unlike some encoder types, AAT-Series sensors detect absolute position, and maintain position information when power is removed. The sensor immediately powers up indicating the correct position.

Application Circuitry

External comparators

A dual comparator can provide digital outputs from AAT angle sensors. Low-power comparators are used to avoid adding power consumption to low-power applications:

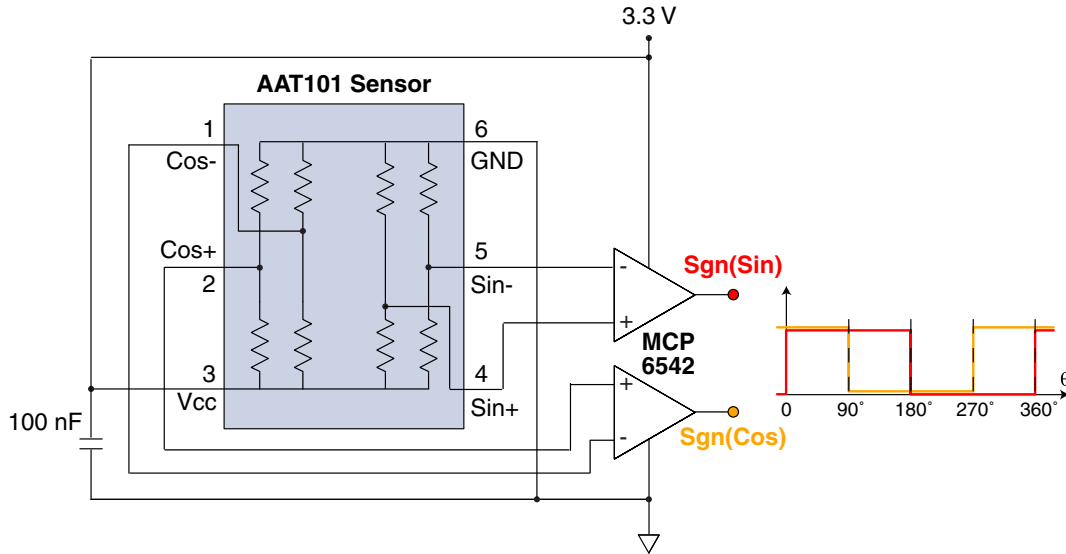

Figure 2. External dual comparator for digital outputs.

Inherent comparator hysteresis eliminates noise at the transition points. The MCP6542 comparator hysteresis of 3.3 mV corresponds to about 1 angular degree of hysteresis. Higher hysteresis comparators can be used for more noise immunity at the expense of angular hysteresis. NVE also offers ADT-Series sensors that include integrated comparators to replicate the circuit of Figure 2.

Quadrant outputs

A 2-to-4 line decoder can provide digital signals to indicate the quadrant of rotation:

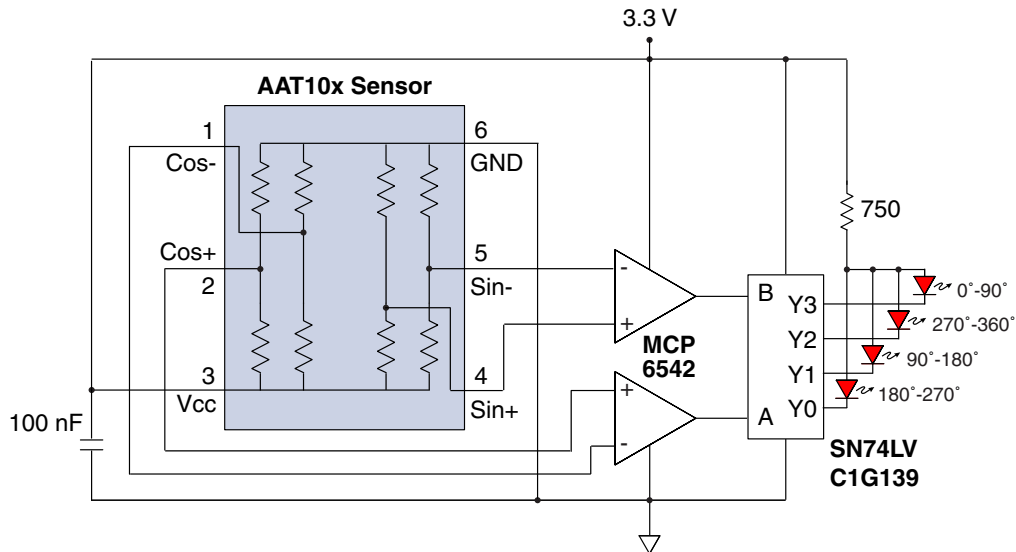

Figure 3. Digital quadrant outputs.

Speed and direction signals

Commodity CMOS circuits can be added to create a precise encoder with direction and speed outputs. A flip-flop determines direction by detecting the phasing between the two outputs. An exclusive-OR gate provides a digital signal with two cycles per revolution, and transitions every 90 degrees:

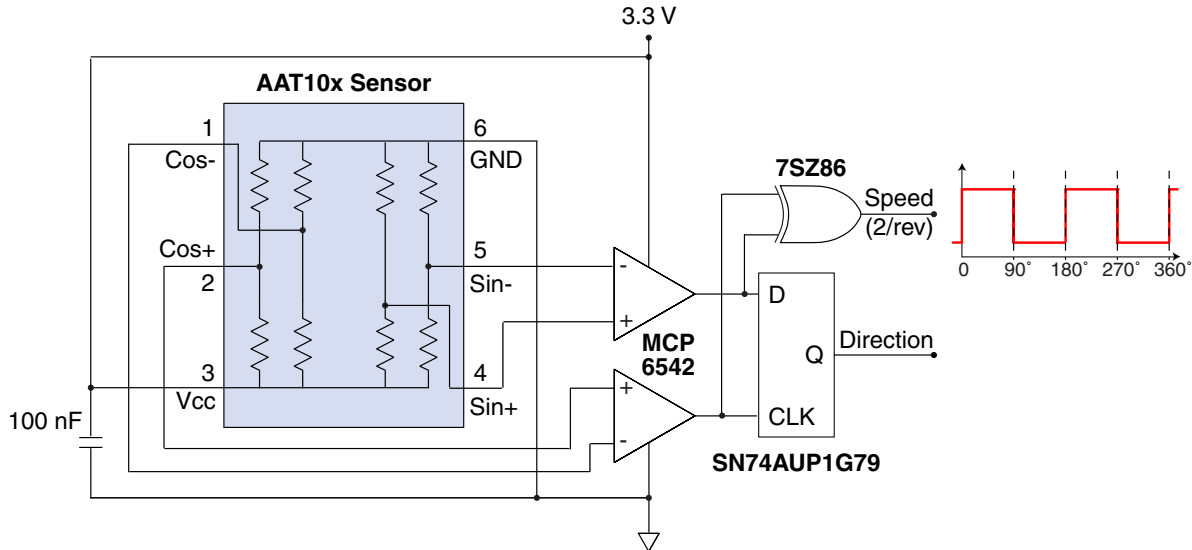

Figure 4. Speed and direction signals.

Simple amplification

AAT-Series sensors have high output signals without amplification, but if single-ended signals or amplification are needed, instrumentation amplifiers can be used to reduce amplifier parts count. The gain should be limited to approximately two to avoid saturating the amplifiers:

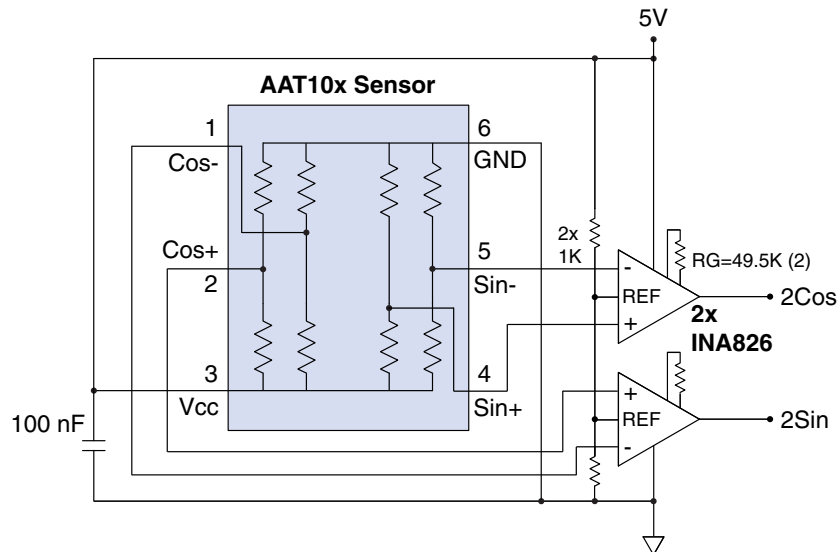

Figure 5. AAT101 with 2x instrumentation amplifiers.

Noise mitigation

High-impedance circuitry is inherently susceptible to noise. Common noise mitigation steps include:

- Power supply decoupling capacitors near the sensor (100 nF typical).
- Limiting the sensor output bandwidth to only what is needed. Because the sensor outputs are resistive, filter capacitors can be connected directly to the outputs. The sensor output impedances are half the bridge resistances, so the cutoff frequency is:

$$f_c = 1/(\pi R_B C)$$

where R_B is the bridge resistance and C is the output capacitance.

- Digital filtering or averaging in microcontroller systems.

External comparator considerations

Low voltage, low quiescent current comparators are generally used to preserve the AAT sensors' ultra-low power and wide supply range.

Some hysteresis in external comparators is desirable to reduce noise and jitter at transition points. Too much hysteresis, however, may cause undesirable errors. Low-hysteresis comparators are especially important in low voltage applications, since hysteresis is a larger portion of the signals. Angular hysteresis relates to comparator hysteresis as follows:

$$\theta_H = \frac{(360/\pi)(V_{HC})}{(V_{CC})(V_{PP})}$$

Where:

- θ_H the angular hysteresis in degrees;
- V_{HC} is the comparator's hysteresis;
- V_{CC} is the sensor power supply; and
- V_{PP} is the sensor's peak-to-peak sensitivity (typically 400 mV/V).

For example, MCP6542 comparators have hysteresis of 3.3 mV, corresponding to about 0.5 angular degree of hysteresis. TLV3691 or similar comparators have hysteresis of 17 mV, corresponding to approximately 3 degrees of hysteresis with a 1.5 V supply.

Ultralow power external CMOS

Any of the application circuits described in this section can use 74AUP-family logic rather than 74LVC if lower power is required and five-volt operation is not needed.

Pinout

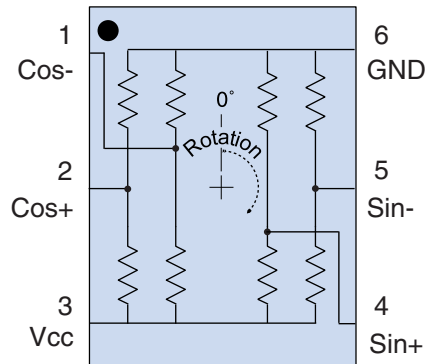

AAT10x Pin	Symbol	Description
1	Cos-	Corresponds to the negative-sine of the rotation angle.
2	Cos+	Corresponds to the sine of the rotation angle.
3	V _{CC}	Supply voltage (up to 5.5 V).
4	Sin+	Corresponds to the cosine of the rotation angle.
5	Sin-	Corresponds to the negative-cosine of the rotation angle.
6	GND	Ground.

Notes:

- Clockwise rotation as viewed from the top of the package is interpreted as increasing angle.
- The package center pad may be left floating or connected to ground.

Revision History

June 2017

Changes

- Clarified repeatability vs. accuracy (p. 2).
- Added nonsinusoidality specifications (p. 2).
- Initial release.

November 2016

Changes

- Preliminary release.

Datasheet Limitations

The information and data provided in datasheets shall define the specification of the product as agreed between NVE and its customer, unless NVE and customer have explicitly agreed otherwise in writing. All specifications are based on NVE test protocols. In no event however, shall an agreement be valid in which the NVE product is deemed to offer functions and qualities beyond those described in the datasheet.

Limited Warranty and Liability

Information in this document is believed to be accurate and reliable. However, NVE does not give any representations or warranties, expressed or implied, as to the accuracy or completeness of such information and shall have no liability for the consequences of use of such information.

In no event shall NVE be liable for any indirect, incidental, punitive, special or consequential damages (including, without limitation, lost profits, lost savings, business interruption, costs related to the removal or replacement of any products or rework charges) whether or not such damages are based on tort (including negligence), warranty, breach of contract or any other legal theory.

Right to Make Changes

NVE reserves the right to make changes to information published in this document including, without limitation, specifications and product descriptions at any time and without notice. This document supersedes and replaces all information supplied prior to its publication.

Use in Life-Critical or Safety-Critical Applications

Unless NVE and a customer explicitly agree otherwise in writing, NVE products are not designed, authorized or warranted to be suitable for use in life support, life-critical or safety-critical devices or equipment. NVE accepts no liability for inclusion or use of NVE products in such applications and such inclusion or use is at the customer's own risk. Should the customer use NVE products for such application whether authorized by NVE or not, the customer shall indemnify and hold NVE harmless against all claims and damages.

Applications

Applications described in this datasheet are illustrative only. NVE makes no representation or warranty that such applications will be suitable for the specified use without further testing or modification.

Customers are responsible for the design and operation of their applications and products using NVE products, and NVE accepts no liability for any assistance with applications or customer product design. It is customer's sole responsibility to determine whether the NVE product is suitable and fit for the customer's applications and products planned, as well as for the planned application and use of customer's third party customers. Customers should provide appropriate design and operating safeguards to minimize the risks associated with their applications and products.

NVE does not accept any liability related to any default, damage, costs or problem which is based on any weakness or default in the customer's applications or products, or the application or use by customer's third party customers. The customer is responsible for all necessary testing for the customer's applications and products using NVE products in order to avoid a default of the applications and the products or of the application or use by customer's third party customers. NVE accepts no liability in this respect.

Limiting Values

Stress above one or more limiting values (as defined in the Absolute Maximum Ratings System of IEC 60134) will cause permanent damage to the device. Limiting values are stress ratings only and operation of the device at these or any other conditions above those given in the recommended operating conditions of the datasheet is not warranted. Constant or repeated exposure to limiting values will permanently and irreversibly affect the quality and reliability of the device.

Terms and Conditions of Sale

In case an individual agreement is concluded only the terms and conditions of the respective agreement shall apply. NVE hereby expressly objects to applying the customer's general terms and conditions with regard to the purchase of NVE products by customer.

No Offer to Sell or License

Nothing in this document may be interpreted or construed as an offer to sell products that is open for acceptance or the grant, conveyance or implication of any license under any copyrights, patents or other industrial or intellectual property rights.

Export Control

This document as well as the items described herein may be subject to export control regulations. Export might require a prior authorization from national authorities.

Automotive Qualified Products

Unless the datasheet expressly states that a specific NVE product is automotive qualified, the product is not suitable for automotive use. It is neither qualified nor tested in accordance with automotive testing or application requirements. NVE accepts no liability for inclusion or use of non-automotive qualified products in automotive equipment or applications.

In the event that customer uses the product for design-in and use in automotive applications to automotive specifications and standards, customer (a) shall use the product without NVE's warranty of the product for such automotive applications, use and specifications, and (b) whenever customer uses the product for automotive applications beyond NVE's specifications such use shall be solely at customer's own risk, and (c) customer fully indemnifies NVE for any liability, damages or failed product claims resulting from customer design and use of the product for automotive applications beyond NVE's standard warranty and NVE's product specifications.

An ISO 9001 Certified Company

NVE Corporation
11409 Valley View Road
Eden Prairie, MN 55344-3617 USA
Telephone: (952) 829-9217
Fax: (952) 829-9189
www.nve.com
e-mail: sensor-info@nve.com

©NVE Corporation
All rights are reserved. Reproduction in whole or in part is prohibited without the prior written consent of the copyright owner.

SB-00-055_AAT101-10E

June 2017