



Chipsmall Limited consists of a professional team with an average of over 10 year of expertise in the distribution of electronic components. Based in Hongkong, we have already established firm and mutual-benefit business relationships with customers from,Europe,America and south Asia,supplying obsolete and hard-to-find components to meet their specific needs.

With the principle of “Quality Parts,Customers Priority,Honest Operation,and Considerate Service”,our business mainly focus on the distribution of electronic components. Line cards we deal with include Microchip,ALPS,ROHM,Xilinx,Pulse,ON,Everlight and Freescale. Main products comprise IC,Modules,Potentiometer,IC Socket,Relay,Connector.Our parts cover such applications as commercial,industrial, and automotives areas.

We are looking forward to setting up business relationship with you and hope to provide you with the best service and solution. Let us make a better world for our industry!



Contact us

Tel: +86-755-8981 8866 Fax: +86-755-8427 6832

Email & Skype: info@chipsmall.com Web: www.chipsmall.com

Address: A1208, Overseas Decoration Building, #122 Zhenhua RD., Futian, Shenzhen, China



Five/Six-Channel Push/Pull I/O Expander

General Description

The AAT4296/98 SmartSwitch is a member of Skyworks' Application Specific Power MOSFET (ASPM™) product family. The AAT4296/98 is comprised of five/six push/pull output switches that gate each respective output between a common input supply and ground. This device is targeted for I/O expansion applications, but can also be used for a combination of general purposes to simplify power switching with an off state load discharge.

The AAT4296/98 operates over an input voltage range of 1.8V to 5.5V, making it ideal for battery-powered applications. The state of each output channel is controlled with a single GPIO via the EN/SET pin using Skyworks Simple Serial Control (S²Cwire™) interface. When EN/SET is pulled to logic high, the device is enabled and consumes 3μA of typical quiescent current. In the off state, each output is pulled low to ground to affect a logic low state for I/O expander or power switching applications; this circuit will act as a load discharge function to rapidly turn off a load circuit.

Rated over the -40°C to +85°C temperature range, the AAT4296 is offered in a Pb-free 8-pin SC70JW package, and the AAT4298 is offered in both a Pb-free 10-pin SC70JW and a Pb-free 12-pin TSOPJW package.

Features

- V_{IN} Range: 1.8V to 5.5V
- Independent Push/Pull Channels
 - AAT4296: Five Channels
 - AAT4298: Six Channels
- User-Programmable Interface
- Single GPIO Controls State of Each Output
- Optional Fast Auto-Discharge
- Low Quiescent Current: 3μA Typical
- Temperature Range: -40°C to +85°C
- Available in Pb-Free Packages:
 - AAT4296: 8-Pin SC70JW
 - AAT4298: 10-Pin SC70JW and 12-Pin TSOPJW

Applications

- Cell Phones
- Multiple Low Power Switching
- Personal Communication Devices
- Portable Electronic Devices

Typical Application

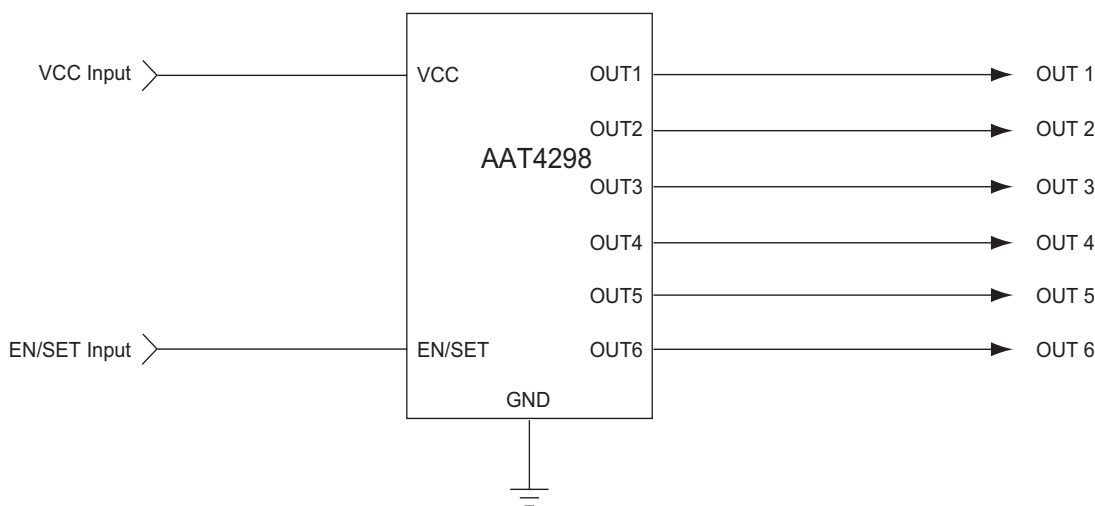

AAT4296/4298

Five/Six-Channel Push/Pull I/O Expander

Pin Descriptions

Pin #			Symbol	Function
AAT4296	AAT4298 SC70JW-10	AAT4298 TSOPJW-12		
1	7	8	VCC	Input supply voltage.
2	8	9	OUT2	Channel 2 output pin.
3	9	10	OUT1	Channel 1 output pin.
4	10	11	EN/SET	Input control pin using S ² Cwire serial interface. The device records rising edges of the clock and decodes them into 32 (AAT4296) or 64 (AAT4298) states controlling the ON/OFF states of the outputs. See Table 1 for output settings. In addition, a logic low forces the device into shutdown mode, reducing the supply current to less than 1µA. This pin should not be left floating.
5	1	2	GND	Ground.
6	3	3	OUT5	Channel 5 output pin.
7	4	4	OUT4	Channel 4 output pin.
8	5	5	OUT3	Channel 3 output pin.
N/A	6	7	OUT6	Channel 6 output pin.
N/A	2	1, 6, 12	N/C	Not connected.

Pin Configuration

**AAT4296
SC70JW-8
(Top View)**

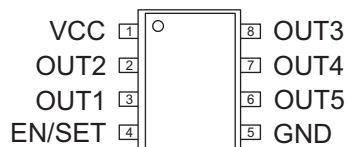

**AAT4298
SC70JW-10
(Top View)**

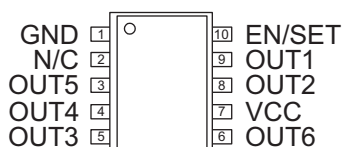

**AAT4298
TSOPJW-12
(Top View)**

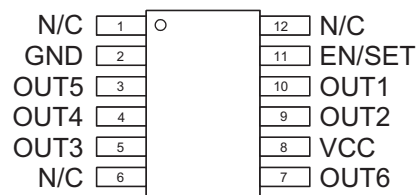

AAT4296/4298

Five/Six-Channel Push/Pull I/O Expander

Absolute Maximum Ratings¹

Symbol	Description	Value	Units
V_{CC} to GND	Input to GND	-0.3 to 6.0	V
OUTx to GND	Output (Source) to GND	-0.3 to $V_{IN} + 0.3$	V
EN/SET	EN/SET to GND	-0.3 to 6.0	V
T_J	Operating Junction Temperature Range	-40 to +150	°C

Thermal Information

Symbol	Description	Value	Units	
θ_{JA}	Thermal Resistance ²	SC70JW-8, SC70JW-10	225	°C/W
		TSOPJW-12	160	
P_D	Maximum Power Dissipation ³	SC70JW-8, SC70JW-10	440	mW
		TSOPJW-12	625	

1. Stresses above those listed in Absolute Maximum Ratings may cause permanent damage to the device. Functional operation at conditions other than the operating conditions specified is not implied. Only one Absolute Maximum Rating should be applied at any one time.

2. Mounted on an FR4 board.

3. Derate 4.4mW/°C above 25°C.

AAT4296/4298**Five/Six-Channel Push/Pull I/O Expander****Electrical Characteristics¹**

$V_{CC} = 5.0V$; $T_A = -40^{\circ}C$ to $+85^{\circ}C$, unless otherwise noted. Typical values are $T_A = 25^{\circ}C$.

Symbol	Description	Conditions	Min	Typ	Max	Units
V_{CC}	Supply Voltage Range		1.8		5.5	V
I_Q	Quiescent Current	EN/SET = $V_{CC} = 5V$, $I_{OUT} = 0$, All Switches ON EN/SET = GND, $V_{CC} = 5V$, OUTx = Open		3.0	10 1.0	μA
$R_{DS(ON)}$	On Resistance P-Channel	$V_{CC} = 5V$		2.5	6.0	Ω
		$V_{CC} = 3.6V$		3.0	7.0	
	On Resistance N-Channel	$V_{CC} = 5V$		1.9	6.0	
		$V_{CC} = 3.6V$		2.0	7.0	
T_{CRDS}	On Resistance Temperature Coefficient			2800		ppm/ $^{\circ}C$
T_{ON}	Output Turn-On Time ²	$V_{CC} = 5V$, $C_{OUT} = 100nF$; $T_A = 25^{\circ}C$		1.6	2.7	μs
T_{OFF}	Output Turn-Off Time ³	$V_{CC} = 5V$, $C_{OUT} = 100nF$; $T_A = 25^{\circ}C$		0.8	2.1	μs
EN/ SET						
$V_{EN(L)}$	Enable Threshold Low	$V_{IN} = 1.8V$			0.4	V
$V_{EN(H)}$	Enable Threshold High	$V_{IN} = 5.5V$	1.4			V
$T_{EN/SET LO}$	EN/SET Low Time		0.5		75	μs
$T_{EN/SET HI MIN}$	Minimum EN/SET High Time			50		ns
$T_{EN/SET HI MAX}$	Maximum EN/SET High Time				75	μs
T_{OFF}	EN/SET Off Timeout				500	μs
T_{LAT}	EN/SET Latch Timeout				500	μs
$I_{EN/SET}$	EN/SET Input Leakage		-1		1	μA

1. The AAT4296/98 is guaranteed to meet performance specifications over the $-40^{\circ}C$ to $+85^{\circ}C$ operating temperature range and is assured by design, characterization, and correlation with statistical process controls.

2. T_{ON} is the time after latch timeout to 90% of the output voltage. See Figure 1.

3. T_{OFF} is the time after off timeout to 10% of the output voltage. See Figure 1.

AAT4296/4298

Five/Six-Channel Push/Pull I/O Expander

Typical Characteristics

Unless otherwise noted, $V_{IN} = 5V$, $C_{IN} = 1\mu F$, $C_{OUTx} = 0.1\mu F$, $T_A = 25^\circ C$.

Quiescent Current vs. Input Voltage

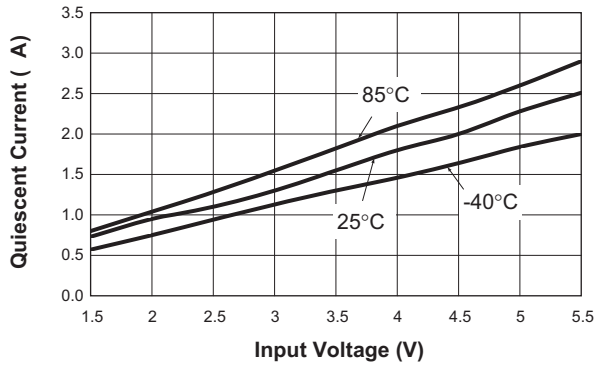

Quiescent Current vs. Temperature

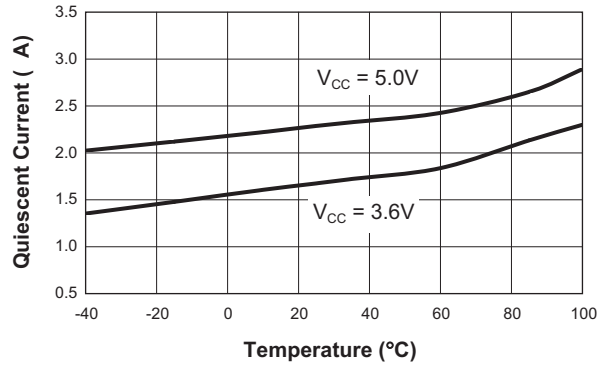

V_{IH} vs. Input Voltage

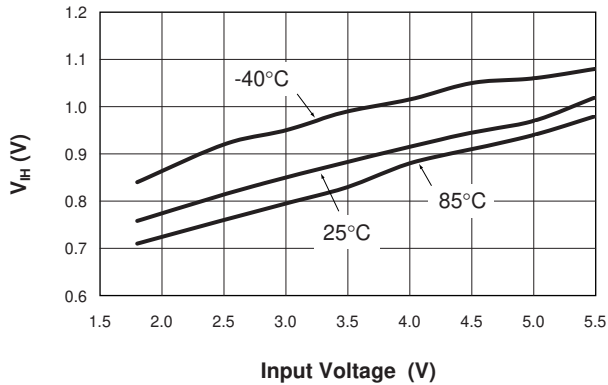

V_{IL} vs. Input Voltage

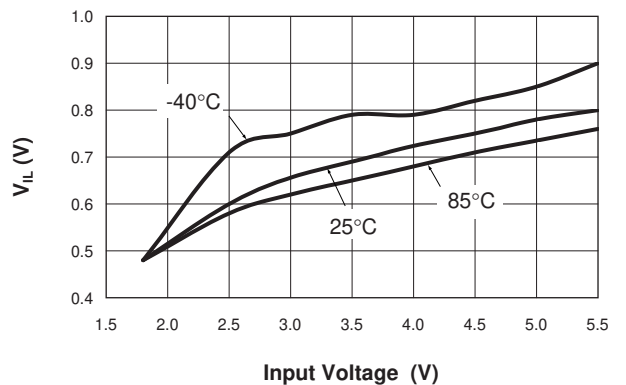

P-Channel $R_{DS(ON)}$ vs. Input Voltage
($I_{LOAD} = 100mA$)

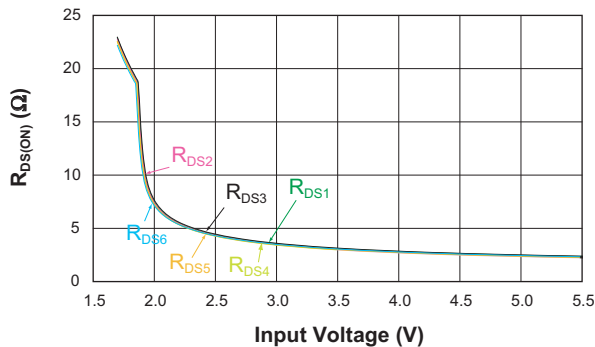

P-Channel $R_{DS(ON)}$ vs. Temperature
($I_{LOAD} = 100mA$)

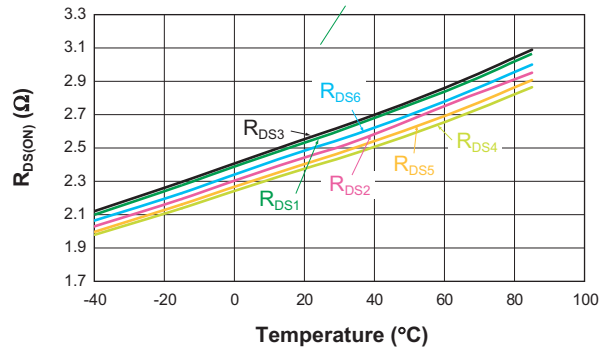

AAT4296/4298

Five/Six-Channel Push/Pull I/O Expander

Typical Characteristics

Unless otherwise noted, $V_{IN} = 5V$, $C_{IN} = 1\mu F$, $C_{OUTx} = 0.1\mu F$, $T_A = 25^\circ C$.

N-Channel $R_{DS(ON)}$ vs. Input Voltage
($I_{LOAD} = 100mA$)

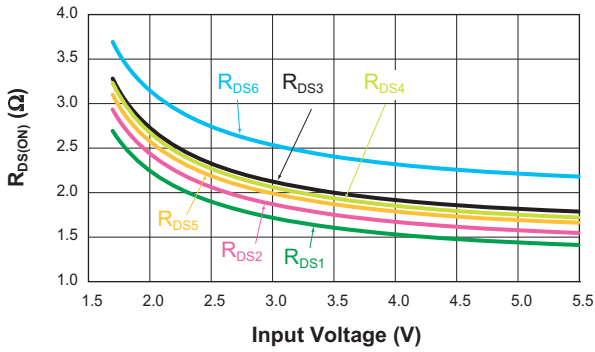

N-Channel $R_{DS(ON)}$ vs. Temperature
($I_{LOAD} = 100mA$)

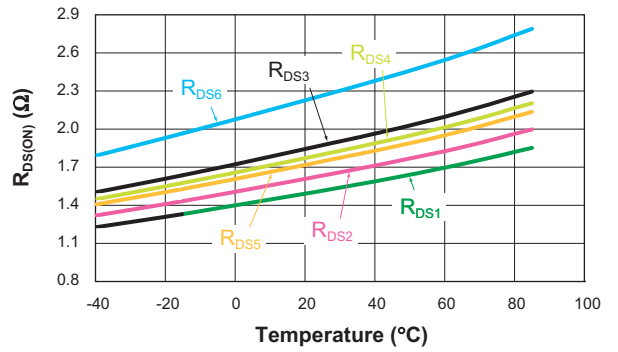

P-Channel $R_{DS(ON)}$ vs. Temperature
($V_{CC} = 3.6V$; $I_{LOAD} = 100mA$)

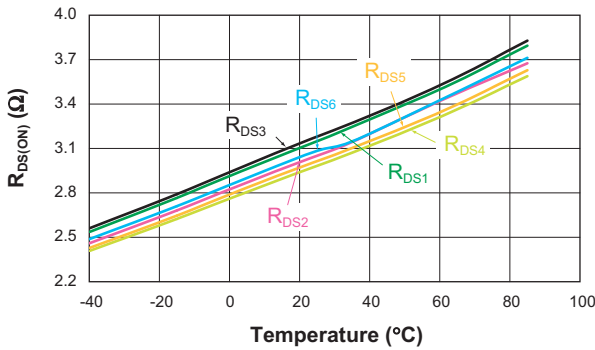

N-Channel $R_{DS(ON)}$ vs. Temperature
($V_{CC} = 3.6V$; $I_{LOAD} = 100mA$)

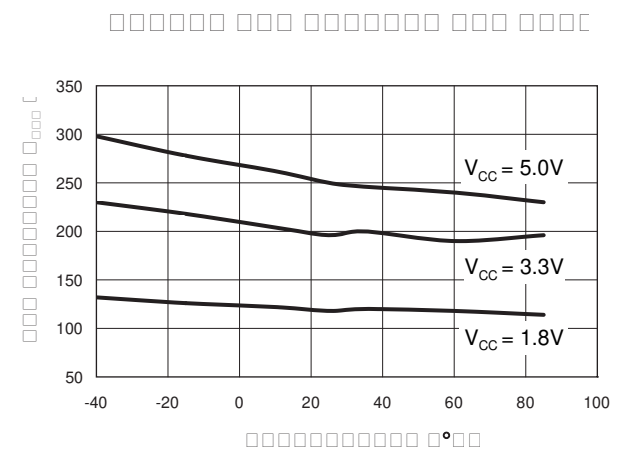
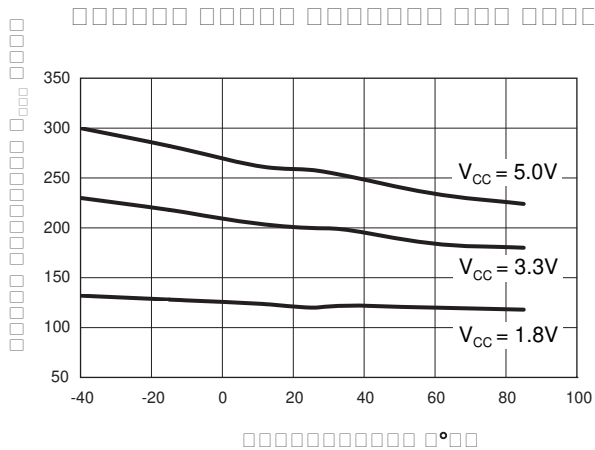
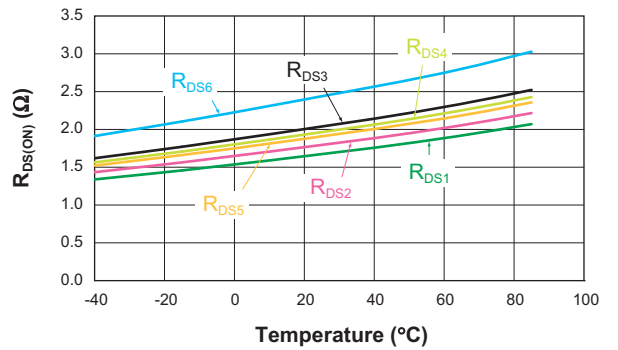

AAT4296/4298

Five/Six-Channel Push/Pull I/O Expander

Typical Characteristics

Unless otherwise noted, $V_{IN} = 5V$, $C_{IN} = 1\mu F$, $C_{OUTx} = 0.1\mu F$, $T_A = 25^\circ C$.

EN/SET Timeout vs. Input Voltage

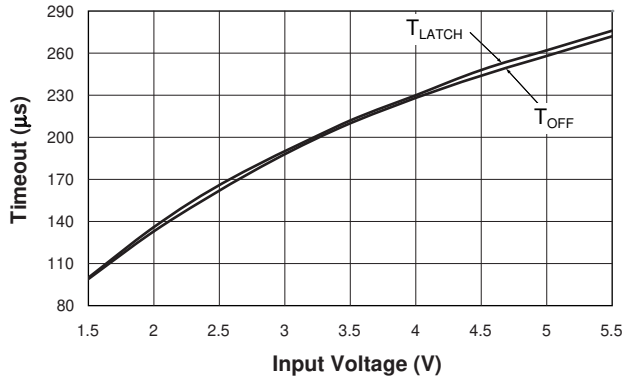

Turn-On and Turn-Off Time vs. Temperature

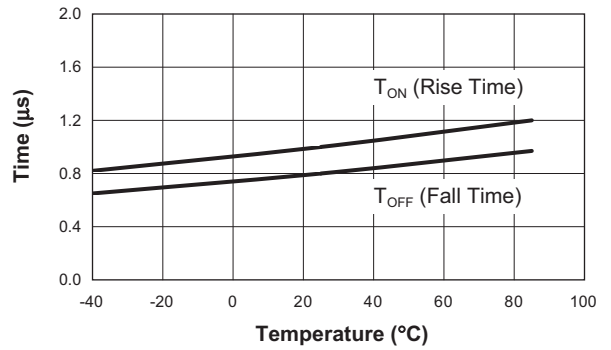

Turn-On Characteristic

($R_{LOAD1} = R_{LOAD2} = 100\Omega$; $C_{OUT1} = C_{OUT2} = 0.1\mu F$)

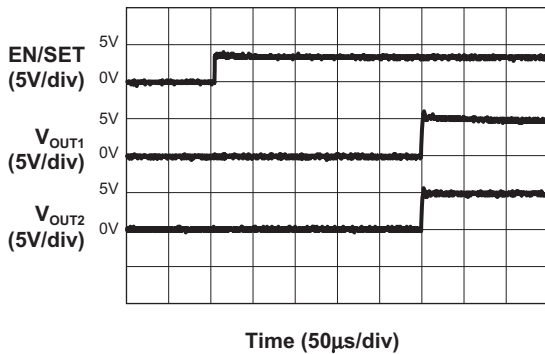

Turn-On Characteristic

($R_{LOAD1} = R_{LOAD2} = 100\Omega$; $C_{OUT1} = C_{OUT2} = 0.1\mu F$)

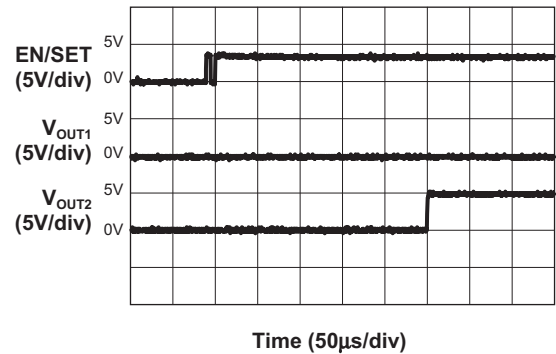

Turn-On Characteristic

($R_{LOAD1} = R_{LOAD2} = 100\Omega$; $C_{OUT1} = C_{OUT2} = 0.1\mu F$)

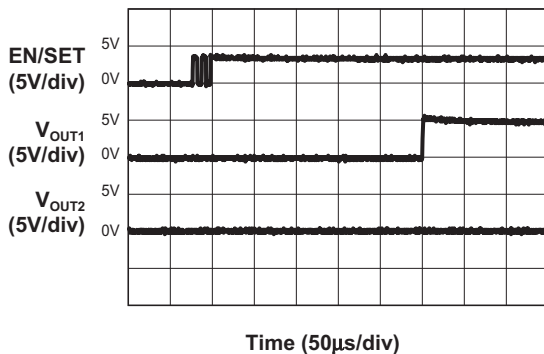

Turn-On Characteristic

($R_{LOAD1} = R_{LOAD2} = 100\Omega$; $C_{OUT1} = C_{OUT2} = 0.1\mu F$)

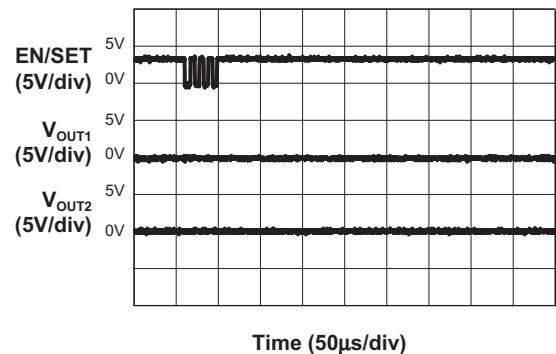

AAT4296/4298

Five/Six-Channel Push/Pull I/O Expander

Typical Characteristics

Unless otherwise noted, $V_{IN} = 5V$, $C_{IN} = 1\mu F$, $C_{OUTx} = 0.1\mu F$, $T_A = 25^\circ C$.

Turn-Off Characteristic
 $(R_{LOAD1} = R_{LOAD2} = 100\Omega; C_{OUT1} = C_{OUT2} = 0.1\mu F)$

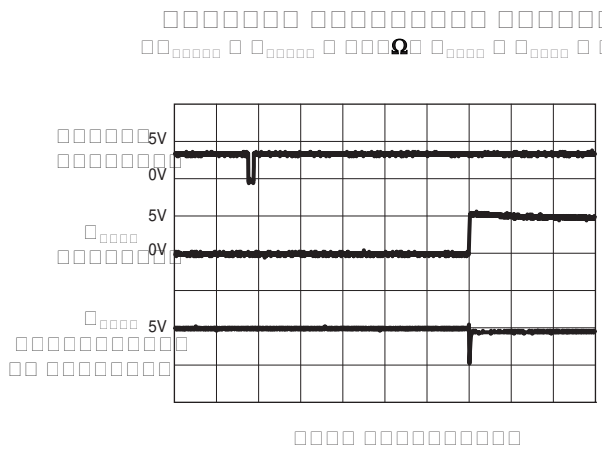
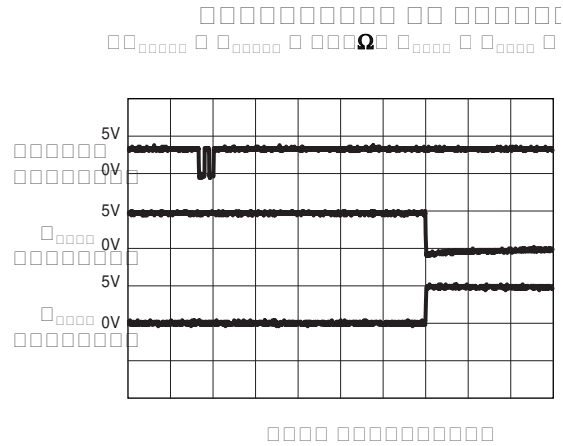
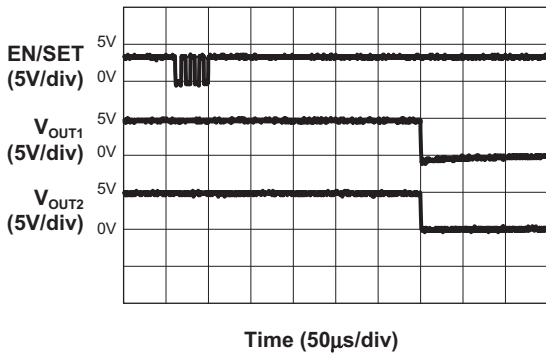

AAT4296/4298

Five/Six-Channel Push/Pull I/O Expander

Functional Block Diagram

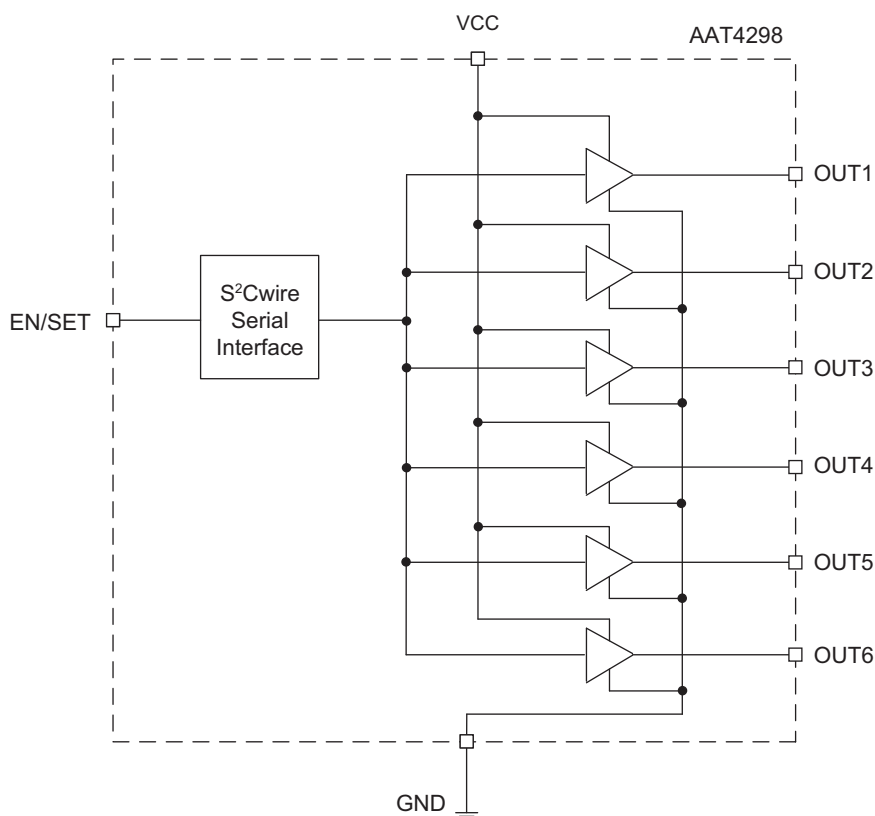

Functional Description

The AAT4296/98 is comprised of five/six push/pull output slew rate limited load switches primarily targeted for microcontroller general purpose input/output (I/O) expansion applications. Each push/pull output is supplied by the common V_{CC} input and is controlled via the digital EN/SET input pin. When a given output is enabled, the voltage source applied to the V_{CC} pin is then switched to the respective output. The high-side P-channel MOSFET transistor has a typical on resistance ($R_{DS(ON)}$) of 3Ω when operating from a 3.6V supply.

When a respective output is disabled or turned off, the given output pin is then connected to ground through a low side N-channel MOSFET with a typical on resistance ($R_{DS(ON)}$) of 2Ω . This circuit architecture affects a simple

logic control with the high level based on the applied V_{CC} . For the AAT4296, this creates a 1-to-5 I/O expander, and for the AAT4298 this creates a 1-to-6 I/O expander. Both the AAT4296 and AAT4298 have been designed to operate with an input voltage range of 1.8V to 5.5V, making them ideal for battery-powered applications.

These devices may also be used for load switching applications, as well as I/O expansion. Since the V_{CC} is gated to each output through a slew rate limited low on-resistance switch, they are ideal for controlling applications circuits with light load current requirements. Such applications could include simple LED function indicator lamps, RGB LED fashion lighting, audio and RF circuits, or any other system with a power requirement that does not exceed the thermal dissipation limits of the load switch and device package.

AAT4296/4298

Five/Six-Channel Push/Pull I/O Expander

Each device push/pull output may be represented by the following circuit and simplified equivalent model (Figures 1 and 2):

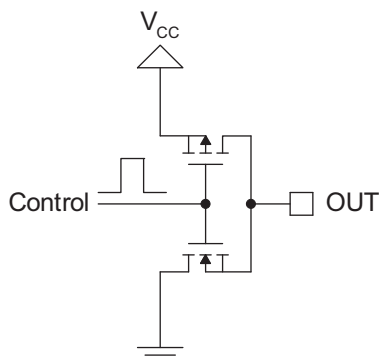

Figure 1: Push/ Pull Output Circuit.

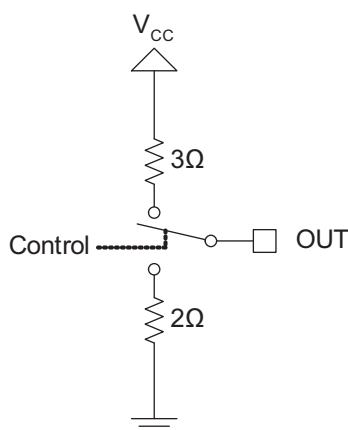

Figure 2: Simplified Equivalent Model.

The state of each output is controlled via the EN/SET pin using Skyworks' S²Cwire interface. To enable a respective switch, a series of clocked pulses should be applied to the EN/SET pin. The number of pulses clocked will determine the switch configuration based on the truth table shown in Table 1. At the end of the serial pulse data set, the EN/SET set pin should be held high to then latch the clocked data and enable the desired switch configu-

ration. When the device is enabled with the EN/SET held to a logic high state, the device quiescent current consumption will typically increase to 3μA and normal ambient room temperatures. If output sequencing of the switches is not necessary, all of the outputs will be switched on simultaneously on the first rising edge of the EN/SET pin by simply pulling the EN/SET to a logic high level. The default switch position for one clock pulse is all switches "on." However, if output sequencing is desired, a series of pulses on the EN/SET pin will set the outputs to the desired state (refer to Table 1 for output settings).

The AAT4296/98 offers two different options when the switches are in the off state. For applications with an active pull down or auto-discharge requirement, the internal N-channel switch will connect the output node to ground with a series resistance of 2Ω.

S²Cwire Serial Interface

The ON/OFF state of the output is controlled by the EN/SET serial data input. An internal control counter is clocked on the rising edge of the EN/SET pin and is decoded into the 32/64 possible states (see Table 1).

The S²Cwire interface relies on the number of rising edges of the EN/SET pin to address and load the registers. S²Cwire latches data or address after the EN/SET pin has been held high for time T_{LAT} . The interface records rising edges of the EN/SET pin and decodes them into 32 (for AAT4296) or 64 (for AAT4298) different states, as indicated in Table 1. There are 32 (for AAT4296)/ 64 (for AAT4298) different sequences for controlling individual turn-on/turn-off of each switch. The counter can be clocked at speeds up to 1MHz, such that intermediate states are not visible. Alternatively, the EN/SET clock pulses may be entered one at a time for desired setting. The first rising edge of EN/SET enables the IC and turns all the switches ON. Once the final clock cycle is received, the EN/SET pin is held high to maintain the device setting. The device is disabled 500μs (T_{OFF}) after the EN/SET pin transitions to a logic low state.

AAT4296/4298

Five/Six-Channel Push/Pull I/O Expander

Clock	AAT4298						Clock	AAT4298					
	OUT6	AAT4296 (only)						OUT6	AAT4298				
		OUT5	OUT4	OUT3	OUT2	OUT1			OUT5	OUT4	OUT3	OUT2	OUT1
1	on	on	on	on	on	on	33	off	on	on	on	on	on
2	on	on	on	on	on	off	34	off	on	on	on	on	off
3	on	on	on	on	off	on	35	off	on	on	on	off	on
4	on	on	on	on	off	off	36	off	on	on	on	off	off
5	on	on	on	off	on	on	37	off	on	on	off	on	on
6	on	on	on	off	on	off	38	off	on	on	off	on	off
7	on	on	on	off	off	on	39	off	on	on	off	off	on
8	on	on	on	off	off	off	40	off	on	on	off	off	off
9	on	on	off	on	on	on	41	off	on	off	on	on	on
10	on	on	off	on	on	off	42	off	on	off	on	on	off
11	on	on	off	on	off	on	43	off	on	off	on	off	on
12	on	on	off	on	off	off	44	off	on	off	on	off	off
13	on	on	off	off	on	on	45	off	on	off	off	on	on
14	on	on	off	off	on	off	46	off	on	off	off	on	off
15	on	on	off	off	off	on	47	off	on	off	off	off	on
16	on	on	off	off	off	off	48	off	on	off	off	off	off
17	on	off	on	on	on	on	49	off	off	on	on	on	on
18	on	off	on	on	on	off	50	off	off	on	on	on	off
19	on	off	on	on	off	on	51	off	off	on	on	off	on
20	on	off	on	on	off	off	52	off	off	on	on	off	off
21	on	off	on	off	on	on	53	off	off	on	off	on	on
22	on	off	on	off	on	off	54	off	off	on	off	on	off
23	on	off	on	off	off	on	55	off	off	on	off	off	on
24	on	off	on	off	off	off	56	off	off	on	off	off	off
25	on	off	off	on	on	on	57	off	off	off	on	on	on
26	on	off	off	on	on	off	58	off	off	off	on	on	off
27	on	off	off	on	off	on	59	off	off	off	on	off	on
28	on	off	off	on	off	off	60	off	off	off	on	off	off
29	on	off	off	off	on	on	61	off	off	off	off	on	on
30	on	off	off	off	on	off	62	off	off	off	off	on	off
31	on	off	off	off	off	on	63	off	off	off	off	off	on
32	on	off	off	off	off	off	64	off	off	off	off	off	off

Table 1: Output Settings.

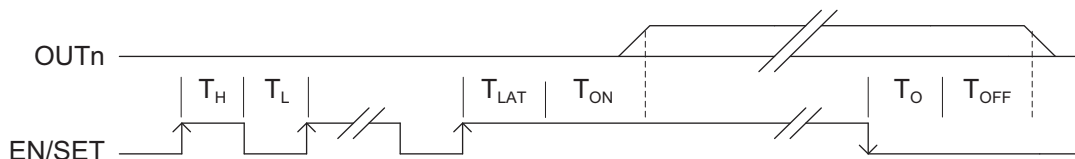

Figure 3: Timing Diagram.

AAT4296/4298

Five/Six-Channel Push/Pull I/O Expander

Applications Information

The AAT4296 and AAT4298 have been designed so that no external parts are required for the device to function as a general purpose I/O expander. Such external parts could include bypass capacitors, or pull-up or pull-down resistors.

For applications which may use some or all of the output to switch light load current levels to application circuits, good engineering practice would dictate the use of small bypass capacitors place on the V_{CC} input and each output which is being used to conduct current to a load. The use of small ceramic capacitors between the input and output nodes to ground will aid in reducing line and load transient response effects. Refer to the application schematic of Figure 4 for an example for placing bypass capacitors.

Input Capacitor

Typically a 0.1 μ F to 1 μ F capacitor is recommended for C_{IN} in most applications. A C_{IN} capacitor is not required for basic operation; however, C_{IN} is useful in preventing load transient effects from affecting upstream circuits when internal switches are enabled to their respective output load circuits. C_{IN} should be located as close to the device V_{IN} pin as practically possible.

There is no specific capacitor equivalent series resistance (ESR) requirement for C_{IN} ; however, for higher current operation, ceramic capacitors are recommended for C_{IN} due to their inherent capability over tantalum or aluminum electrolytic capacitors to withstand input current surges from low impedance sources, such as batteries in portable devices.

Output Capacitor

For typical applications where the AAT4696/98 is used for I/O expansion, no output capacitors are required. Many other common applications such as controlling LED indicator lamps in portable products do not require an output capacitor because the end load is not sensitive to device turn-on transient effects.

For improved load transient response in systems using the AAT4296/98 for load switching, the addition of a small output capacitor placed between the output pins and ground can have a beneficial effect. A 0.1 μ F ceramic capacitor is suggested as a reasonable value for an output capacitor. Please refer to Figure 4.

The output capacitor has no specific capacitor type or ESR requirement. If desired, C_{OUT} may be increased to a value greater than 0.1 μ F without limit to accommodate any load transient condition without adversely affecting the device turn-on slew rate time.

Thermal Considerations

The AAT4296 and AAT4298 are designed to deliver continuous output load currents. The limiting characteristic for maximum safe operating output load current is package power dissipation. In order to obtain high operating currents, careful device layout and circuit operating conditions need to be taken into account.

At any given ambient temperature (T_A), the maximum package power dissipation can be determined by the following equation:

$$P_{D(MAX)} = \frac{T_{J(MAX)} - T_A}{\theta_{JA}}$$

Constants for the AAT4296 and AAT4298 are maximum junction temperature, $T_{J(MAX)} = 125^\circ\text{C}$, and package thermal resistance, $\theta_{JA} = 120^\circ\text{C/W}$. Worst-case conditions are calculated at the maximum operating temperature, where $T_A = 85^\circ\text{C}$. Typical conditions are calculated under normal ambient conditions, where $T_A = 25^\circ\text{C}$.

At 25 $^\circ\text{C}$ ambient, the AAT4296 is capable of dissipating 440mW of power. If all five channels have 5.0V output, the average current is 121mA per channel. The AAT4298 is capable of dissipating 625mW of power. If all six channels have 5.0V output, the average current is 131.5mA per channel.

At 85 $^\circ\text{C}$ ambient, the AAT4296 is capable of dissipating 177.78mW of power. If all five channels have 5.0V output, the average current is 76.5mA per channel. The AAT4298 is capable of dissipating 250mW of power. If all six channels have 5.0V output, the average current is 83mA per channel.

Driving LED Loads

The AAT4296 and AAT4298 can be used to drive LEDs or other applications with light load current requirements. LED applications may include main and sub-LCD display backlighting, camera photo-flash applications, color (RGB) LEDs, and infrared (IR) diodes for remotes. In series with LEDs, ballast resistors must be used to limit

AAT4296/4298

Five/Six-Channel Push/Pull I/O Expander

the LED current. The LED current will vary with supply voltage and LED forward voltage. Most types of LEDs have forward voltage specifications ranging from 2.0V to 5.0V. Calculate the necessary ballast resistor value from the following formula:

$$R_{LED} = \frac{(V_{IN} - V_F)}{I_{LED}} - R_{DS(ON)}$$

Where:

R_{LED} is the resistance of resistor to be placed in series with the LED (Ω).

V_{IN} is the input supply voltage to the device (V).

V_F is the forward voltage of the LED (V).

$R_{DS(ON)}$ is the resistance of the switch when it is turned on (Ω).

I_{LED} is the desired operating current of the LED (A).

Applications Circuit

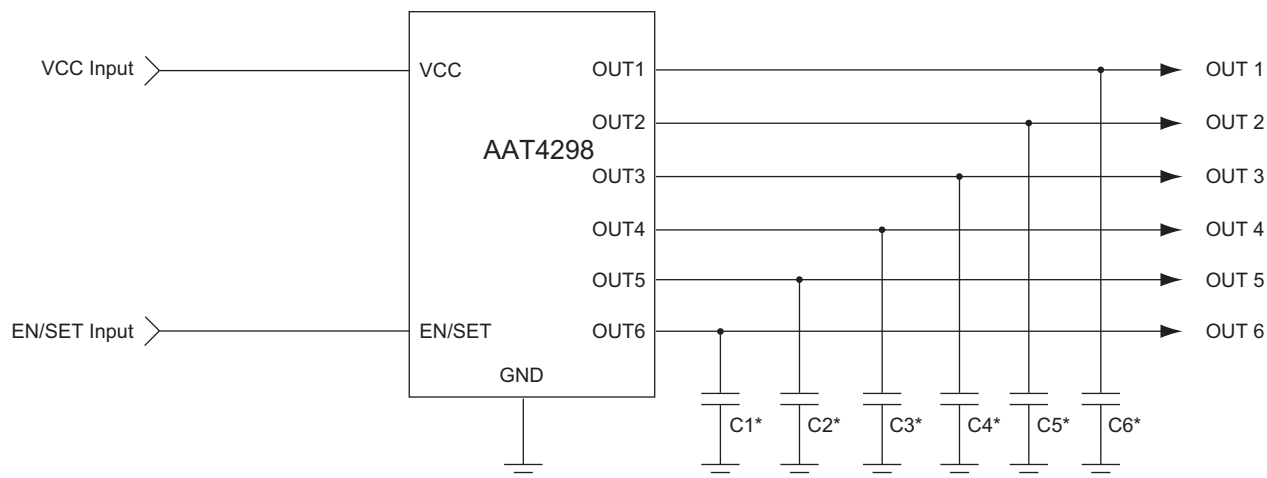

Figure 4: Typical Application Diagram.

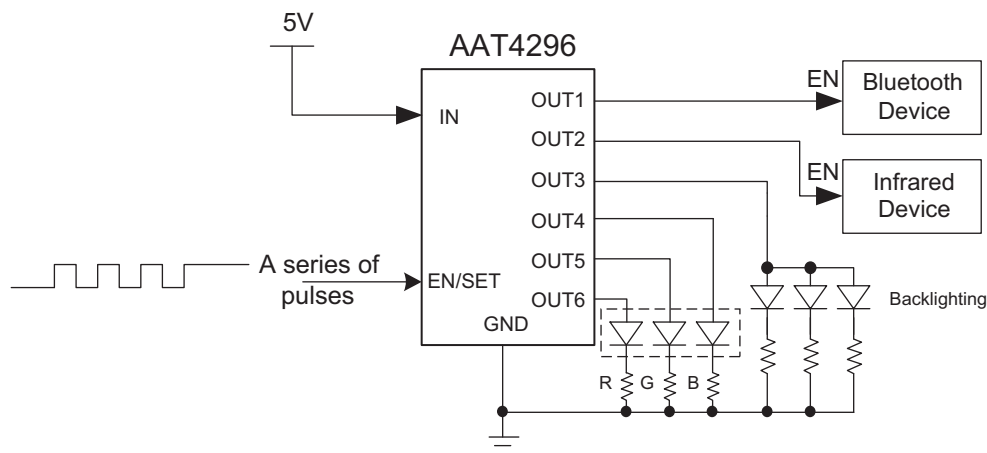

Figure 5: Infrared, Bluetooth, RGB, and Backlighting Control.

* Use of capacitors on each output is optional.

AAT4296/4298

Five/Six-Channel Push/Pull I/O Expander

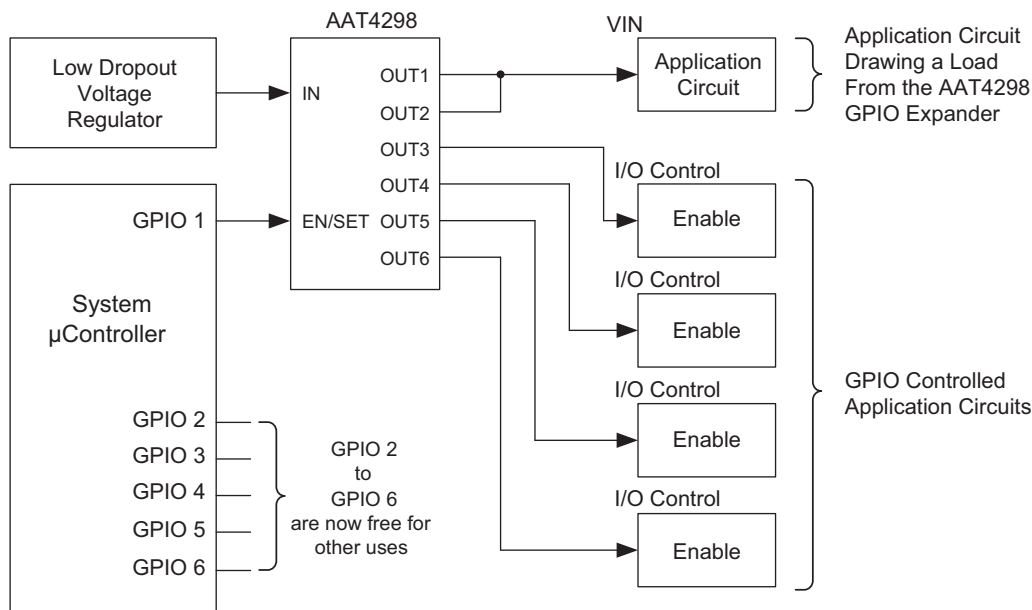

Figure 6: GPIO I / O Expander (Condense Five GPIO Control Lines to One Using AAT4296).

Evaluation Board Description

AAT4296 Evaluation Board

The AAT4296 evaluation board demonstrates the AAT4296 SmartSwitch™ as a microprocessor I/O expand-

er. This chapter describes the evaluation board and its accompanying user interface. A schematic of the complete circuit is shown in Figure 7, and the actual board layout is given in Figures 8 and 9. Table 2 shows the user interface functionality. Table 3 provides the the component list for the AAT4296 evaluation board.

Button(s) Pushed ¹	Description
SW1	[Push/Release once] Toggle On/Off of Output Channel 1.
SW2	[Push/Release once] Toggle On/Off of Output Channel 2.
SW3	[Push/Release once] Toggle On/Off of Output Channel 3.
SW1 + SW2	[Push/Release together] Toggle On/Off of Output Channel 4.
SW2 + SW3	[Push/Release together] Toggle On/Off of Output Channel 5.
SW1 + SW3	[Push/Release together] Auto Cycling. All Outputs blinks (On/Off) five times and goes into Binary-Increment mode.
SW1 + SW2 + SW3	[Push/Release together] Reset: All Outputs go off

Table 2: AAT4296 User Interface Functionality.

1. The '+' sign indicates that these buttons are all pressed and released together.

AAT4296/4298

Five/Six-Channel Push/Pull I/O Expander

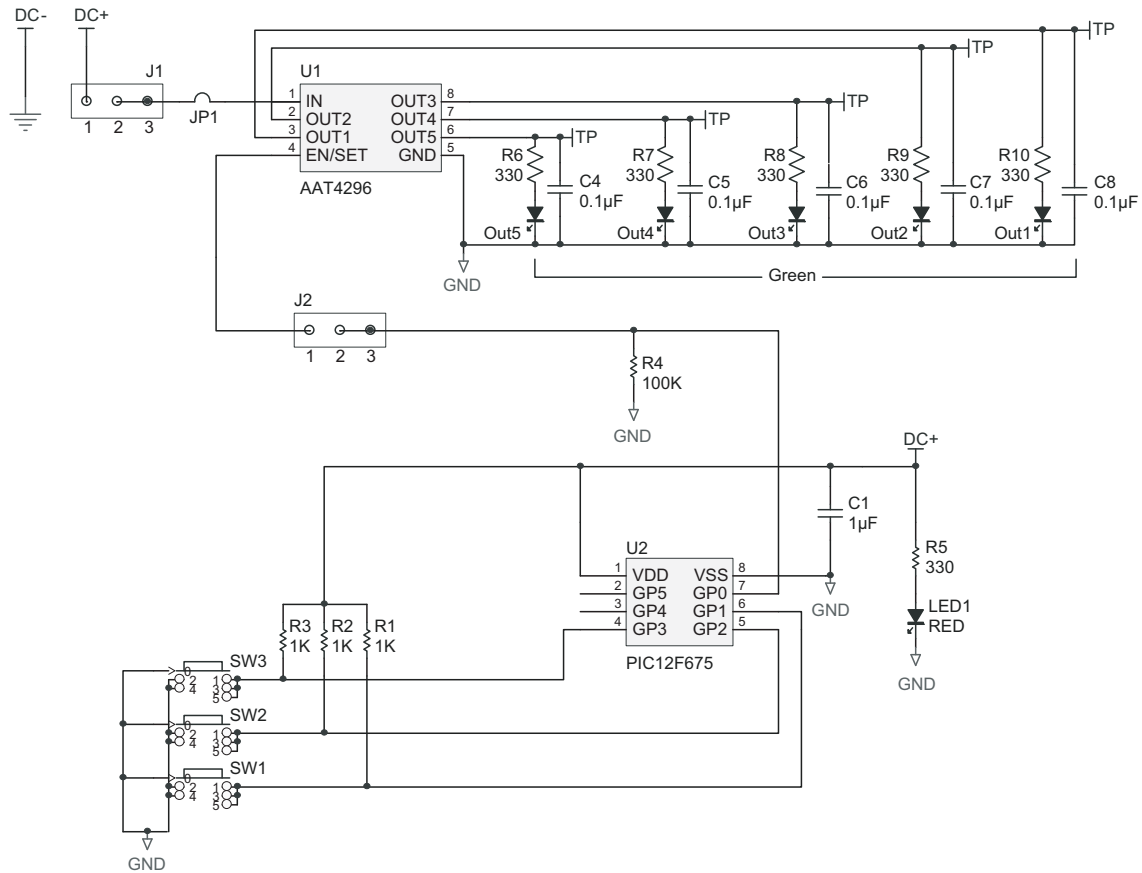

Figure 7: AAT4296 Evaluation Board Schematic.

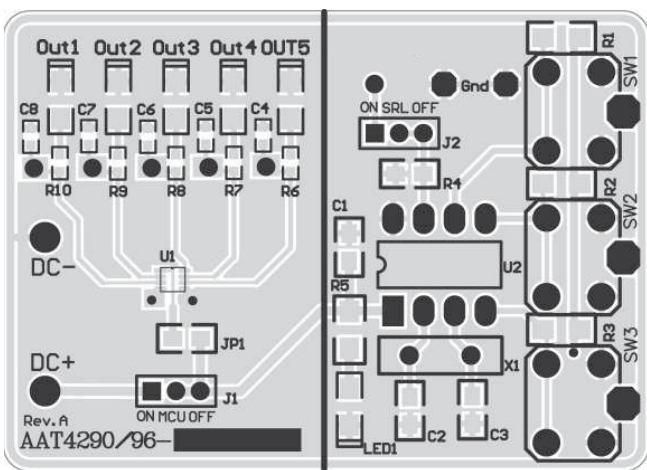

Figure 8: AAT4296 Evaluation Board Top Layer (not to scale).

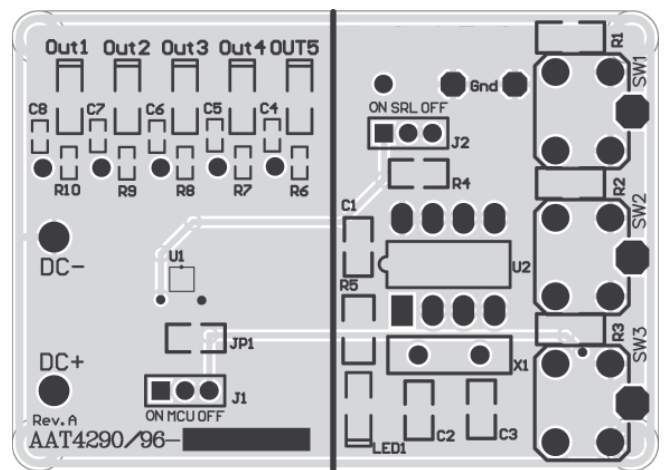

Figure 9: AAT4296 Evaluation Board Bottom Layer (not to scale).

AAT4296/4298

Five/Six-Channel Push/Pull I/O Expander

Component	Part#	Description	Manufacturer
U1	AAT4296IJS	Five-Channel Push/Pull I/O Expander; SC70JW-8 package	Skyworks
U2	PIC12F675	8-bit CMOS, FLASH-based μ C; 8-pin PDIP package	Microchip
SW1 – SW3	PTS645TL50	Switch Tact, SPST, 5mm	ITT Industries
R1 – R3	Chip Resistor	1K, 5%, 1/4W; 1206	Vishay
R4	Chip Resistor	100K, 5%, 1/4W; 0805	Vishay
R5	Chip Resistor	330, 5%, 1/4W; 1206	Vishay
R6-R10	Chip Resistor	330, 5%, 1/4W; 0603	Vishay
JP1	Chip Resistor	0 Ω , 5%; 0805	Vishay
C1	ECJ-2YB1A105K	1 μ F, 10V, X5R, 10%; 0805	Panasonic-ECG
C4-C8 (optional)	GRM188R71C104KA01D	0.1 μ F, 16V, 10%; 0603	Murata
J1, J2	PRPN401PAEN	Con. Header, 2mm zip	Sullins Electronics
LED1	CMD15-21SRC/TR8	Red LED; 1206	Chicago Miniature Lamp
OUT1-OUT5	CMD15-21UGC/TR8	Green LED; 1206	Chicago Miniature Lamp

Table 3: AAT4296 Evaluation Board Component Listing.

AAT4298 Evaluation Board

The AAT4298 evaluation board demonstrates the AAT4298 SmartSwitch™ with a microprocessor I/O expander application. This application shows how a microcontroller can free up five I/O ports by connecting one I/O port to the AAT4298's EN/SET pin.

A schematic of the complete circuit is shown in Figure 10, and the actual board layout is given in Figures 11 and 12. Table 4 shows the user interface functionality. Table 5 provides the the component list for the AAT4298 evaluation board.

Button(s) Pushed ¹	Description
SW1	[Push/Release once] Toggle On/Off of Output Channel 1.
SW2	[Push/Release once] Toggle On/Off of Output Channel 2.
SW3	[Push/Release once] Toggle On/Off of Output Channel 3.
SW4	[Push/Release once] Toggle On/Off of Output Channel 4.
SW1 + SW2	[Push/Release together] Toggle On/Off of Output Channel 5.
SW3 + SW4	[Push/Release together] Toggle On/Off of Output Channel 6.
SW5	[Push/Release once] Reset: All Outputs go off
	[Hold ~ 1.5 second] Auto Cycling. All Outputs blinks (On/Off) five times and device begins binary increment mode.

Table 4: AAT4298 User Interface Functionality.

1. The '+' sign indicates that these buttons are all pressed and released together.

AAT4296/4298

Five/Six-Channel Push/Pull I/O Expander

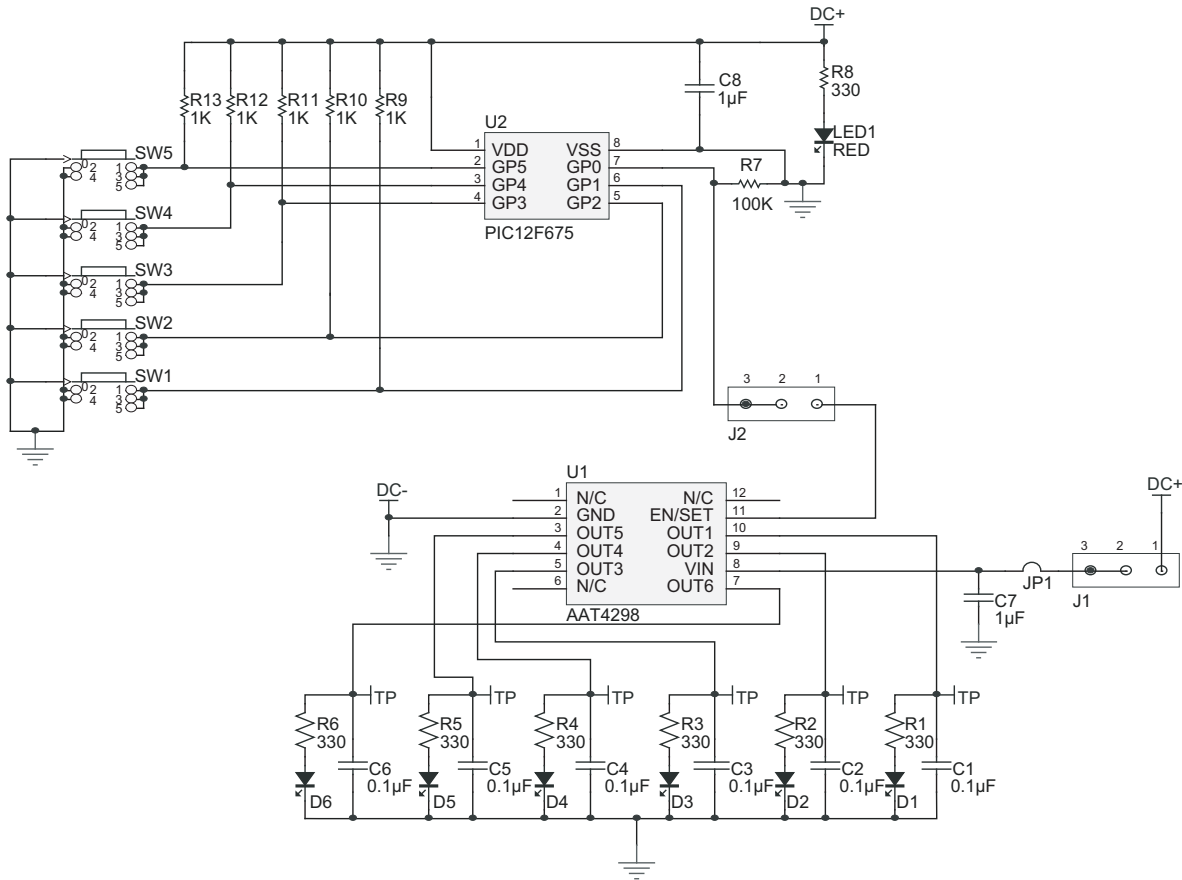

Figure 10: AAT4298 Evaluation Board Schematic.

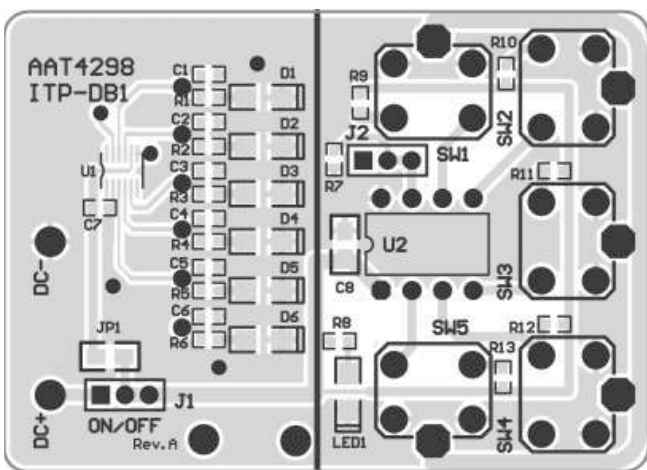

Figure 11: AAT4298 Evaluation Board Top Layer (not to scale).

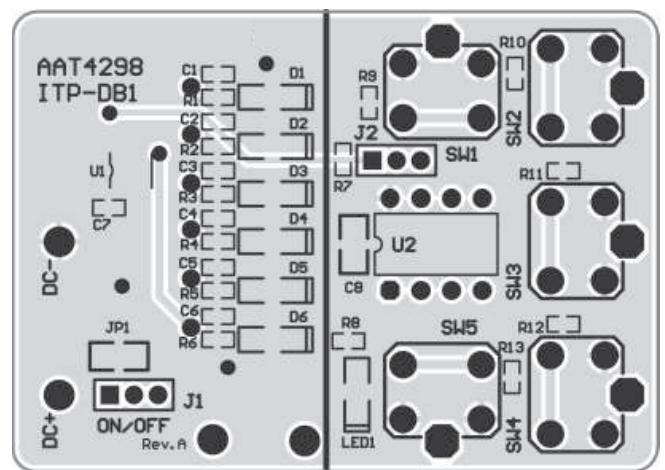

Figure 12: AAT4298 Evaluation Board Bottom Layer (not to scale).

AAT4296/4298***Five/Six-Channel Push/Pull I/O Expander***

Component	Part#	Description	Manufacturer
U1	AAT4298ITP	Six-Channel Push/Pull I/O expander; TSOPJW-12 Package	Skyworks
U2	PIC12F675	8-bit CMOS, FLASH-based μ C; 8-pin PDIP package	Microchip
SW1 – SW5	PTS645TL50	Switch Tact, SPST, 5mm	ITT Industries
R1 – R6, R8	Chip Resistor	330 Ω , 5%, 1/4W; 0603	Vishay
R7	Chip Resistor	100k Ω , 5%, 1/4W; 0603	Vishay
R9 – R13	Chip Resistor	1k Ω , 5%, 1/4W; 0603	Vishay
JP1	Chip Resistor	0 Ω , 5%; 0805	Vishay
C1 – C6 (optional)	GRM188R71C104KA01D	0.1 μ F, 16V, 10%; 0603	Murata
C7	GRM188R61A105KA61B	1 μ F, 10V, X5R, 10%; 0603	Murata
C8	GRM21BR71C105KA01B	1 μ F, 16V, X7R, 10%; 0805	Murata
J1, J2	PRPN401PAEN	Con. Header, 2mm zip	Sullins Electronics
LED1	CMD15-21SRC/TR8	Red LED; 1206	Chicago Miniature Lamp
OUT1-OUT6	CMD15-21UGC/TR8	Green LED; 1206	Chicago Miniature Lamp

Table 5: AAT4298 Evaluation Board Component Listing.

AAT4296/4298

Five/Six-Channel Push/Pull I/O Expander

Ordering Information

Package	Marking ¹	Part Number (Tape and Reel) ²
SC70JW-8	QIXYY	AAT4296I JS-T1
SC70JW-10		AAT4298IJQ-T1
TSOPJW-12	QEXYY	AAT4298I TP-T1



Skyworks Green™ products are compliant with all applicable legislation and are halogen-free.

For additional information, refer to *Skyworks Definition of Green™*, document number SQ04-0074.

Package Information

SC70JW-8

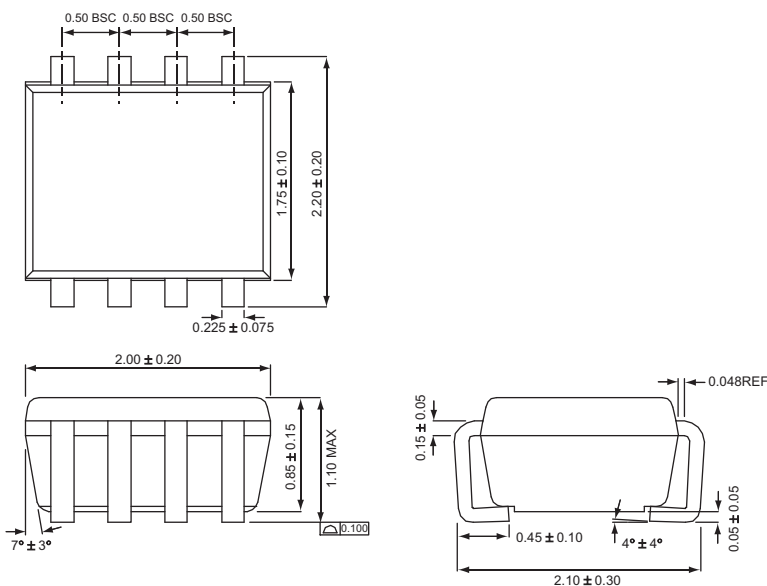

All dimensions in millimeters.

1. XYY = assembly and date code.
2. Sample stock is generally held on part numbers listed in **BOLD**.

AAT4296/4298

Five/Six-Channel Push/Pull I/O Expander

SC70JW-10

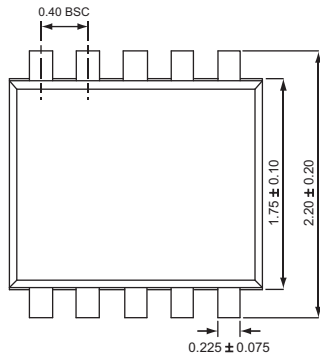

Top View

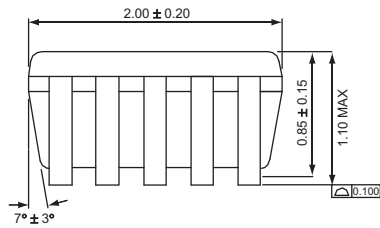

Side View

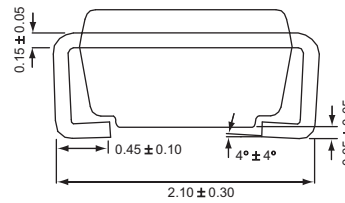

End View

TSOPJW-12

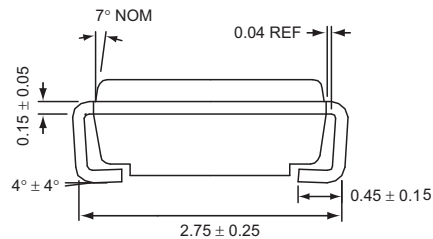
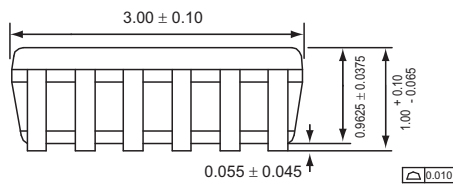
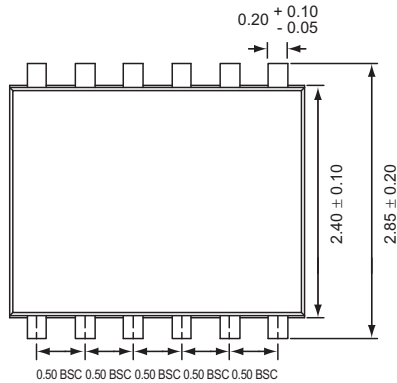

All dimensions in millimeters.

AAT4296/4298

Five/Six-Channel Push/Pull I/O Expander

Copyright © 2012, 2013 Skyworks Solutions, Inc. All Rights Reserved.

Information in this document is provided in connection with Skyworks Solutions, Inc. ("Skyworks") products or services. These materials, including the information contained herein, are provided by Skyworks as a service to its customers and may be used for informational purposes only by the customer. Skyworks assumes no responsibility for errors or omissions in these materials or the information contained herein. Skyworks may change its documentation, products, services, specifications or product descriptions at any time, without notice. Skyworks makes no commitment to update the materials or information and shall have no responsibility whatsoever for conflicts, incompatibilities, or other difficulties arising from any future changes.

No license, whether express, implied, by estoppel or otherwise, is granted to any intellectual property rights by this document. Skyworks assumes no liability for any materials, products or information provided hereunder, including the sale, distribution, reproduction or use of Skyworks products, information or materials, except as may be provided in Skyworks Terms and Conditions of Sale.

THE MATERIALS, PRODUCTS AND INFORMATION ARE PROVIDED "AS IS" WITHOUT WARRANTY OF ANY KIND, WHETHER EXPRESS, IMPLIED, STATUTORY, OR OTHERWISE, INCLUDING FITNESS FOR A PARTICULAR PURPOSE OR USE, MERCHANTABILITY, PERFORMANCE, QUALITY OR NON-INFRINGEMENT OF ANY INTELLECTUAL PROPERTY RIGHT; ALL SUCH WARRANTIES ARE HEREBY EXPRESSLY DISCLAIMED. SKYWORKS DOES NOT WARRANT THE ACCURACY OR COMPLETENESS OF THE INFORMATION, TEXT, GRAPHICS OR OTHER ITEMS CONTAINED WITHIN THESE MATERIALS. SKYWORKS SHALL NOT BE LIABLE FOR ANY DAMAGES, INCLUDING BUT NOT LIMITED TO ANY SPECIAL, INDIRECT, INCIDENTAL, STATUTORY, OR CONSEQUENTIAL DAMAGES, INCLUDING WITHOUT LIMITATION, LOST REVENUES OR LOST PROFITS THAT MAY RESULT FROM THE USE OF THE MATERIALS OR INFORMATION, WHETHER OR NOT THE RECIPIENT OF MATERIALS HAS BEEN ADVISED OF THE POSSIBILITY OF SUCH DAMAGE.

Skyworks products are not intended for use in medical, lifesaving or life-sustaining applications, or other equipment in which the failure of the Skyworks products could lead to personal injury, death, physical or environmental damage. Skyworks customers using or selling Skyworks products for use in such applications do so at their own risk and agree to fully indemnify Skyworks for any damages resulting from such improper use or sale.

Customers are responsible for their products and applications using Skyworks products, which may deviate from published specifications as a result of design defects, errors, or operation of products outside of published parameters or design specifications. Customers should include design and operating safeguards to minimize these and other risks. Skyworks assumes no liability for applications assistance, customer product design, or damage to any equipment resulting from the use of Skyworks products outside of stated published specifications or parameters.

Skyworks, the Skyworks symbol, and "Breakthrough Simplicity" are trademarks or registered trademarks of Skyworks Solutions, Inc., in the United States and other countries. Third-party brands and names are for identification purposes only, and are the property of their respective owners. Additional information, including relevant terms and conditions, posted at www.skyworksinc.com, are incorporated by reference.