



Chipsmall Limited consists of a professional team with an average of over 10 year of expertise in the distribution of electronic components. Based in Hongkong, we have already established firm and mutual-benefit business relationships with customers from,Europe,America and south Asia,supplying obsolete and hard-to-find components to meet their specific needs.

With the principle of “Quality Parts,Customers Priority,Honest Operation,and Considerate Service”,our business mainly focus on the distribution of electronic components. Line cards we deal with include Microchip,ALPS,ROHM,Xilinx,Pulse,ON,Everlight and Freescale. Main products comprise IC,Modules,Potentiometer,IC Socket,Relay,Connector.Our parts cover such applications as commercial,industrial, and automotives areas.

We are looking forward to setting up business relationship with you and hope to provide you with the best service and solution. Let us make a better world for our industry!



Contact us

Tel: +86-755-8981 8866 Fax: +86-755-8427 6832

Email & Skype: info@chipsmall.com Web: www.chipsmall.com

Address: A1208, Overseas Decoration Building, #122 Zhenhua RD., Futian, Shenzhen, China



Airborne™ Embedded Wireless Ethernet Bridge Module Ethernet to 802.11b/g Wireless LAN

WLNG-ET-DP100 Enterprise Series

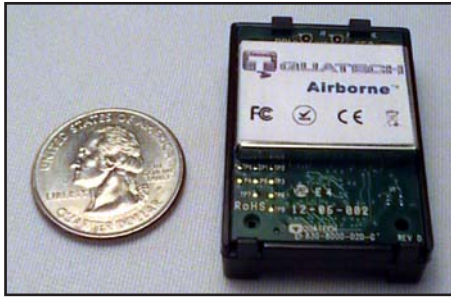

using one of the available, easy to use management interfaces. The Airborne unit allows you to customize their settings to meet your application demands.

Applications

The Airborne modules have been designed and tested to provide Wireless LAN (WLAN) and Internet connectivity across the harshest of machine to machine environments including:

- transportation
- medical
- warehouse and logistics
- point-of-sale (POS)
- industrial automation
- military
- scientific research

Any system with an existing Ethernet port can be wirelessly enabled by connecting the Airborne Ethernet Bridge module directly to the output of its Ethernet PHY, maintaining current firmware and software while enhancing system functionality.

The Evaluation & Design Kit provides software and utilities that allow a developer to quickly and easily operate and evaluate the Bridge module.

High performance device networking solutions

Airborne™ is a line of highly integrated 802.11 modules. The wireless ethernet bridge module includes a radio (which may be purchased separately), a base-band processor, an application processor and software for a "drop-in" web-enabled Wi-Fi solution. Since there's no need to develop the software, or to develop the RF and communications expertise inhouse, OEMs can realize reduced product development costs and a quick time-to-market. This Airborne Wireless Ethernet Module provides instant LAN and Internet connectivity, and connects through a standard ethernet interface (other Airborne modules offer standard serial interfaces) to a wide variety of applications.

Simple configuration, advanced security

The extremely small footprint design makes Airborne easy to embed in both existing and new designs. Supporting advanced security modes, including WEP, WPA and LEAP, the module is interoperable with industry standard 802.11 Access Points and stations. Providing access to existing infrastructure that enables access to corporate WLANs, WANs and even the internet. The built-in TCP/IP stack and application software provide embedded devices with this level of connectivity, without requiring any software development - only simple configuration

KEY FEATURES

- Extended operating temperature range (-30°C to +85°C) and environmental specifications, including shock and vibration tolerance
- Advanced security: WEP (64 & 128 bit), WPA and 802.1x (LEAP) authentication
- Highly integrated transparent 802.11b/g Wireless Ethernet Bridge
- Quick time to market and reduced development costs
- Integrated 10 base-T Ethernet PHY
- Software-configurable 802.11b/g interface
- Integrated RTOS, TCP/IP Stack and CLI
- Reduces need for RF and communications expertise
- FCC Part 15 Class B Sub C Modular Approval
- 5 year warranty

Model Selection Guide

Model No.	Interface	WiFi	Security		
	10 Base-T Ethernet	802.11b/g	WEP (64 & 128 bit)	WPA	LEAP
WLNG-ET-DP101	●	●	●	●	●
To evaluate all available features and receive evaluation tools, order below.					
ABEG-ET-DP104	Evaluation & Design Kit				

All Quatech 802.11b/g products are RoHS-compliant.

Block Diagram

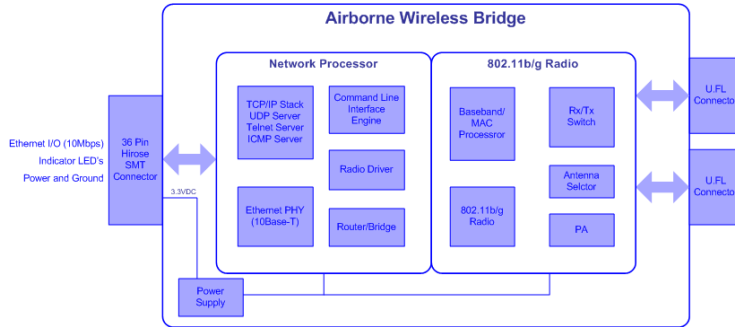

Mechanical Outline

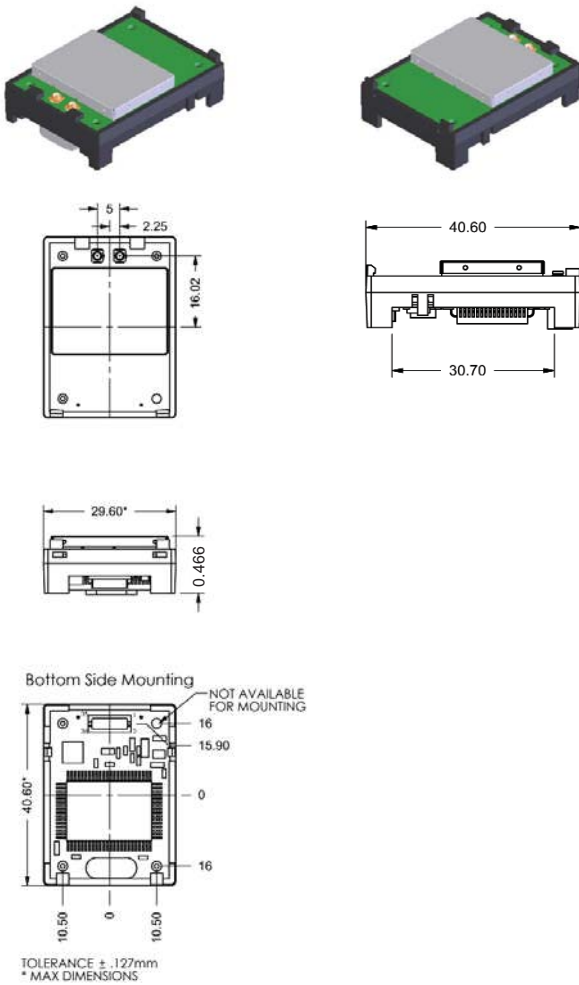

Specifications

Technology	IEEE 802.11b/g, WiFi compliant (802.11i, 802.11e, 802.11d capable)
Ethernet Interface Data Throughput	10 Base-T (4Mbps data throughput max)
Frequency	2.400 ~ 2.4835 GHz (US/Can/Europe) 2.400 ~ 2.497 GHz (Japan)
Modulation Technology	DSS, CCK, OFDM
Modulation Type	DBPSK, DQPSK, CCK, BPSK, QPSK, 16QAM, 64QAM
Network Access Modes	Ad-hoc, Infrastructure
Channels	USA/Canada: 11 channels (1 - 11) Europe: 13 channels (1 - 13) Japan: 14 channels (1 - 13 for g rates) (1 - 14 for b rates) France: 4 channels (10 - 13)
Wireless Data Rate	802.11b mode: 11, 5.5, 2, 1 Mbps 802.11g mode: 54, 48, 36, 24, 18, 12, 9, 6 Mbps
MAC	CSMA/CA with ACK, RTS, CTS
Protocols Data Transfer	TCP/IP, ARP, ICMP, DHCP, DNS, UDAP Discovery TCP/IP, TFTP, UDP
RF Power	+19.3 dBm (typical) Approx. 85 mW peak for B rates +15 dBm (typical) Approx. 32 mW average for B rates +21.5 dBm (typical) Approx. 143 mW peak for G rates +12 dBm (typical) Approx. 16 mW average for G rates
Sensitivity	-71dBm for 54Mbps -77dBm for 36Mbps -83dBm for 18 Mbps -85dBm for 11Mbps -87dBm for 1Mbps
Security	WEP 64 and 128bit (RC4), WPA (TKIP), 802.1x (LEAP)
Antenna	Two U.F.L coaxial connectors, 50 ohms, supports receive diversity
Supply	3.3 Vdc +/-5%
Current Consumption	575mA - transmit mode (typical @ 54mb/s) 375mA - receive mode (typical @ 54mb/s)
Power Up Inrush-Current	3000 mA (MAX) 20ms
Operating Environment Temperature	Temperature: -30°C - +85°C Relative humidity: 5% - 95% (non-condensing) Vibration: 20G peak-to-peak, 20Hz - 2KHz Shock: 1500G peak-to-peak, 0.5mS
Connector	36 Pin (Hirose DF12-36DS-0.5 V) 4-mm height
Agency Approvals	FCC Part 15 Class B Sub C Intentional CE ETSI EN300 328, EN301 489, ETSI 60950-1 IC RSS210 RoHS and WEEE compliant