



Chipsmall Limited consists of a professional team with an average of over 10 year of expertise in the distribution of electronic components. Based in Hongkong, we have already established firm and mutual-benefit business relationships with customers from,Europe,America and south Asia,supplying obsolete and hard-to-find components to meet their specific needs.

With the principle of “Quality Parts,Customers Priority,Honest Operation,and Considerate Service”,our business mainly focus on the distribution of electronic components. Line cards we deal with include Microchip,ALPS,ROHM,Xilinx,Pulse,ON,Everlight and Freescale. Main products comprise IC,Modules,Potentiometer,IC Socket,Relay,Connector.Our parts cover such applications as commercial,industrial, and automotives areas.

We are looking forward to setting up business relationship with you and hope to provide you with the best service and solution. Let us make a better world for our industry!



Contact us

Tel: +86-755-8981 8866 Fax: +86-755-8427 6832

Email & Skype: info@chipsmall.com Web: www.chipsmall.com

Address: A1208, Overseas Decoration Building, #122 Zhenhua RD., Futian, Shenzhen, China



SMD MICROPROCESSOR CRYSTAL

ABLS7M



RoHS / RoHS II Compliant



7.0 x 4.1 x 2.3mm

Moisture Sensitivity Level (MSL) – This product is Hermetically Sealed and not Moisture Sensitive - MSL = N/A: Not Applicable

FEATURES:

- **Reduced footprint from ABL5 (standard HC/49US package) by 50%**
- Low profile: 2.3mm max. height
- Suitable for RoHS compliant reflow
- Tight stability & extended temperature options
- High reliability & Cost effective
- Resistance welded metal package

APPLICATIONS:

- Wireless Applications
- Home electronics
- Computers, modems, and communications
- Microprocessors

STANDARD SPECIFICATIONS:

Parameters	Minimum	Typical	Maximum	Units	Notes
Frequency Range*	12.0		40.0	MHz	
Standard Frequencies	12.0, 12.288, 13.5, 13.56, 14.31818, 14.7456, 16.0, 18.432, 20.0, 20.5, 24.0, 24.576, 25.0, 26.0, 27.0			MHz	
Operation Mode	Fundamental (AT-cut)				
Operating Temperature	0		+70	°C	See options
Storage Temperature	-40		+125	°C	
Frequency Tolerance @+25°C	-50		+50	ppm	See options
Frequency Stability over the Operating Temperature (ref. to +25°C)	-50		+50	ppm	See options
Equivalent series resistance (R1) @+25°C			60	Ω	12.000 ~ 16.000MHz
			40		16.001 ~ 30.000MHz
			25		30.001 ~ 40.000MHz
Shunt capacitance (C0)			5	pF	
Load capacitance (CL)	18			pF	Standard (See options if other than STD)
Drive Level		50	100	μW	
Aging	-5		+5	ppm	@25°C±3°C First year
Insulation Resistance	500			MΩ	@ 100Vdc ± 15V
Drive level dependency (DLD)	10nw ~ 100uw, 12 points Change in ESR (Maximum - Minimum) over DLD range < 30% ESR max.				

* Please contact Abracon for other frequencies.



SMD MICROPROCESSOR CRYSTAL

ABLS7M



RoHS / RoHS II Compliant



7.0 x 4.1 x 2.3mm

PART IDENTIFICATIONS: (left blank if standard)

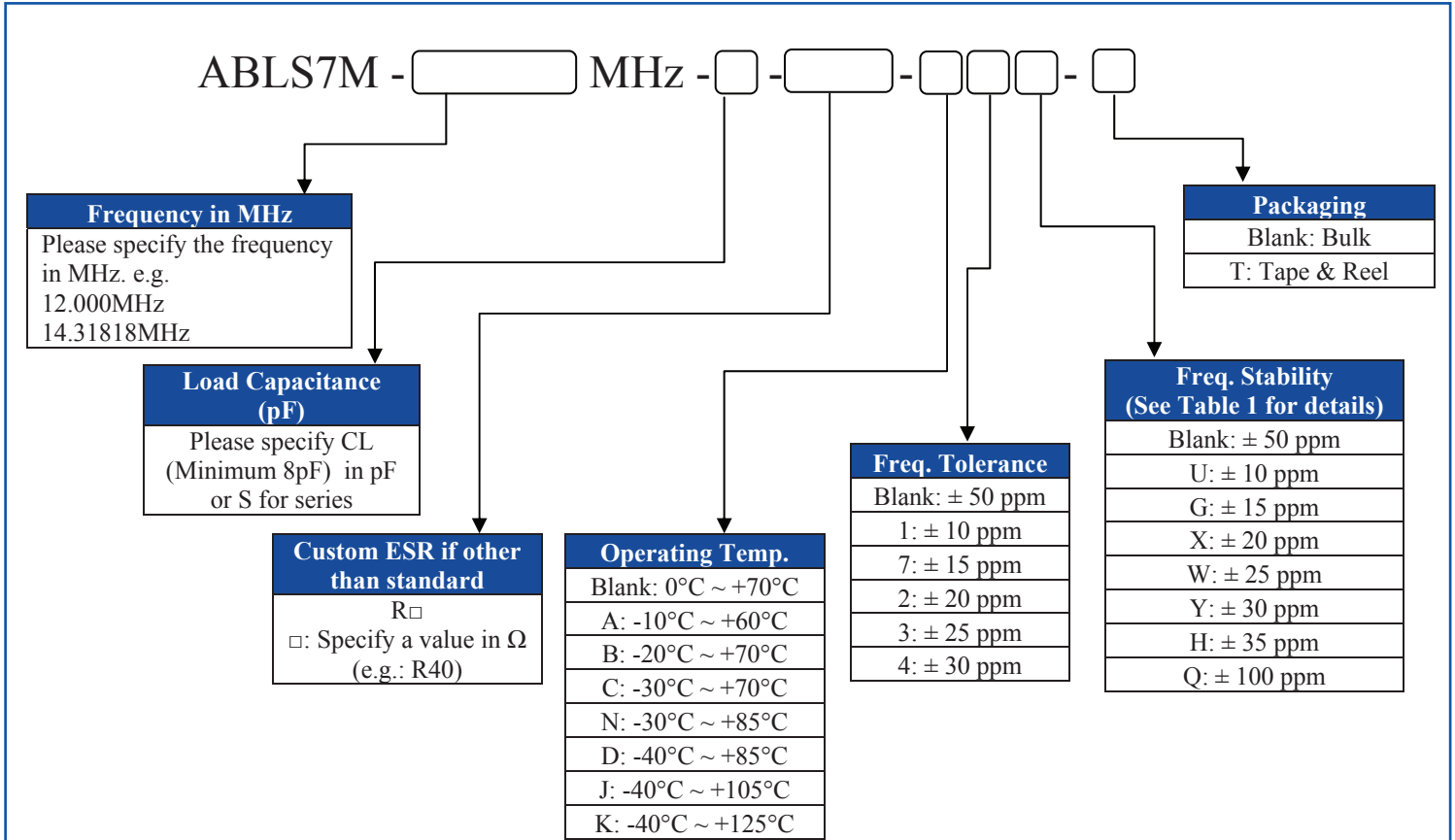

Table 1 Available Combinations of Operating Temp. and Freq. Stability

Operating Temp.	Freq. Stability							
	U:±10ppm	G:±15ppm	X:±20ppm	W:±25ppm	Y:±30ppm	H:±35ppm	Std.:±50ppm	Q:±100ppm
A: -10°C ~ +60°C	√	√	√	√	√	√	√	√
Std.: 0°C ~ +70°C	√	√	√	√	√	√	√	√
B: -20°C ~ +70°C		√	√	√	√	√	√	√
C: -30°C ~ +70°C			√	√	√	√	√	√
N: -30°C ~ +85°C					√	√	√	√
D: -40°C ~ +85°C					√	√	√	√
J: -40°C ~ +105°C							√	√
K: -40°C ~ +125°C								√

Note: Please contact Abracon for other frequency stability and operating temperature range options.



SMD MICROPROCESSOR CRYSTAL

ABLS7M



RoHS / RoHS II Compliant



7.0 x 4.1 x 2.3mm

OUTLINE DIMENSION:

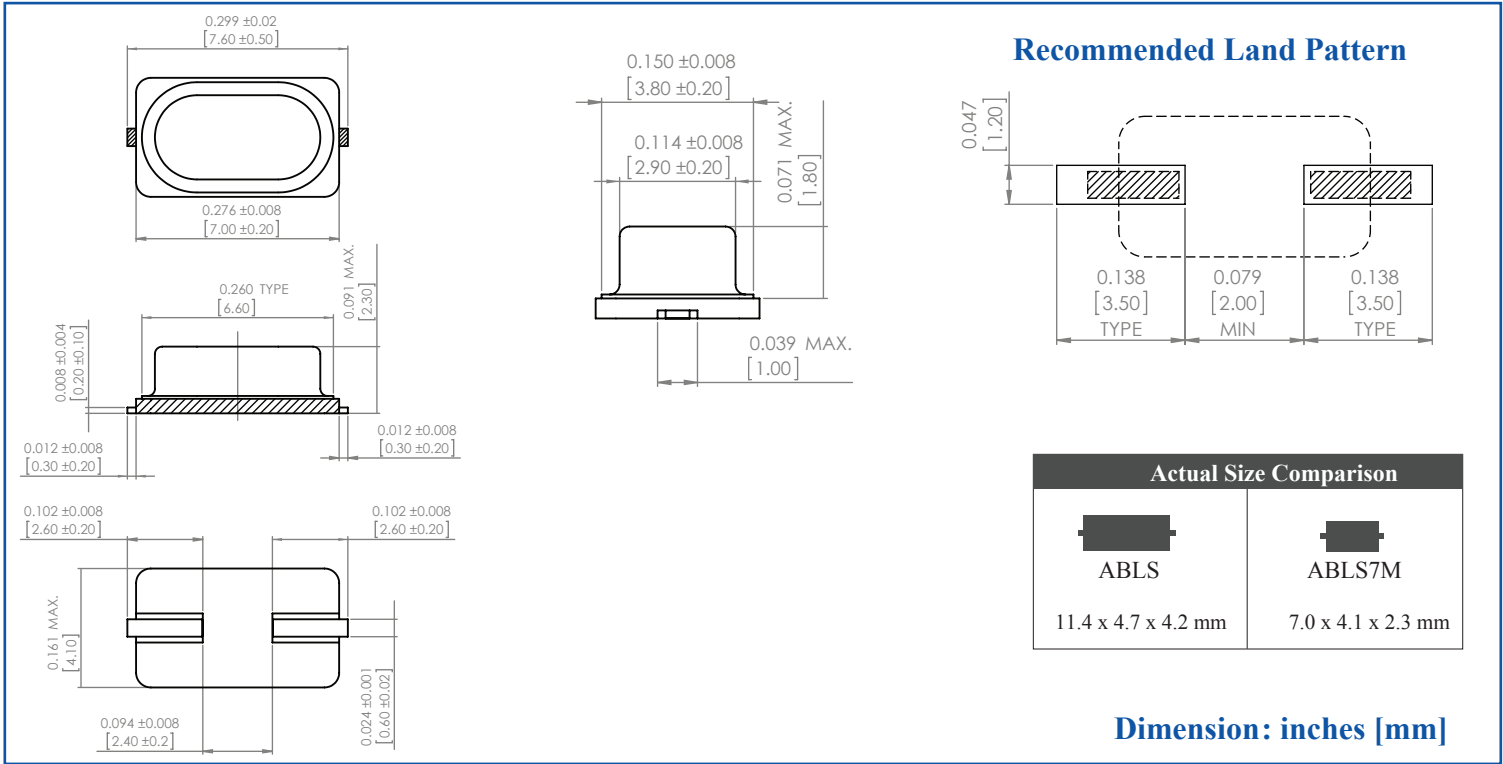

REFLOW PROFILE:

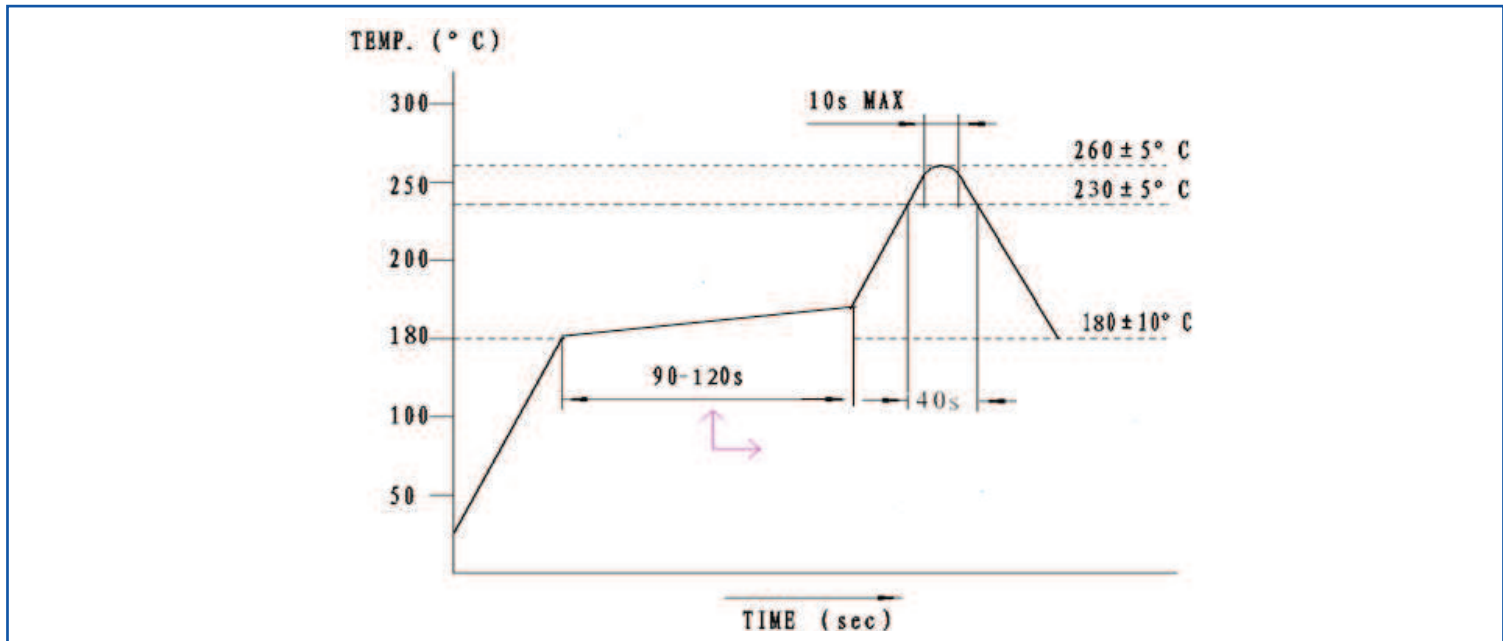

SMD MICROPROCESSOR CRYSTAL

ABLS7M



RoHS / RoHS II Compliant



7.0 x 4.1 x 2.3mm

TAPE & REEL:

T = tape and reel (3000pcs/reel)

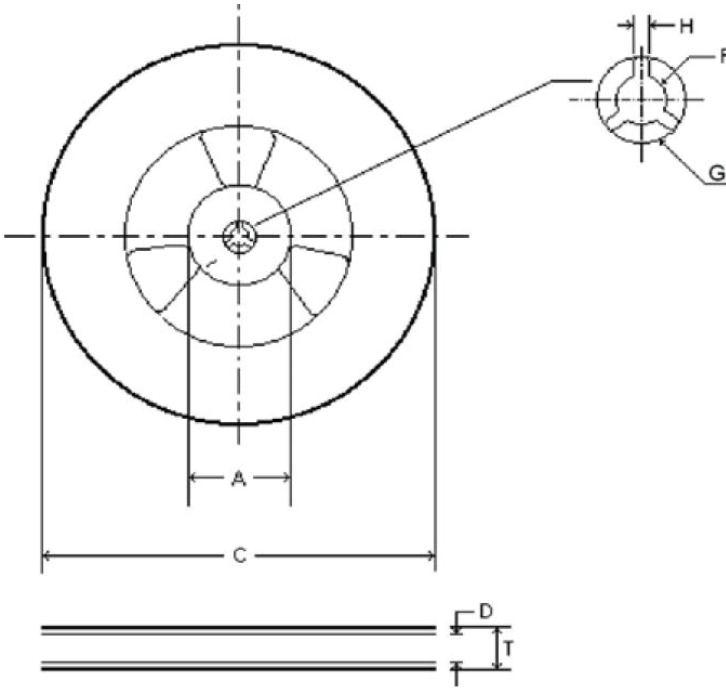

No.	Dimensions (mm)
A	100 ± 1.0
C	330 ± 2.0
D	16.4 ± 1.0
T	20.4 ± 0.5
F	13.0 ± 0.2
G	20.2 min.
H	1.5 min.

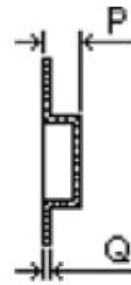
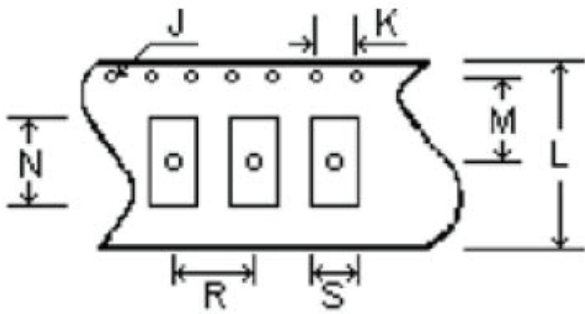

No.	Dimensions (mm)
J	Ø1.5
K	4.0 ± 0.1
L	16.0 ± 0.3
M	7.5 ± 0.1
N	9.4 ± 0.1
P	2.5 ± 0.1
Q	0.3 ± 0.05
R	8.0 ± 0.1
S	4.4 ± 0.1

Dimensions: mm

ATTENTION: Abracon Corporation's products are COTS – Commercial-Off-The-Shelf products; suitable for Commercial, Industrial and, where designated, Automotive Applications. Abracon's products are not specifically designed for Military, Aviation, Aerospace, Life-dependant Medical applications or any application requiring high reliability where component failure could result in loss of life and/or property. For applications requiring high reliability and/or presenting an extreme operating environment, written consent and authorization from Abracon Corporation is required. Please contact Abracon Corporation for more information.

ABRACON IS
ISO9001:2008
CERTIFIED



ABRACON
CORPORATION

2 Faraday, Suite# B | Irvine | CA 92618 **Revised: 01.06.15**

Ph. 949.546.8000 | Fax. 949.546.8001

Visit www.abracon.com for Terms and Conditions of Sale