



Chipsmall Limited consists of a professional team with an average of over 10 year of expertise in the distribution of electronic components. Based in Hongkong, we have already established firm and mutual-benefit business relationships with customers from,Europe,America and south Asia,supplying obsolete and hard-to-find components to meet their specific needs.

With the principle of “Quality Parts,Customers Priority,Honest Operation,and Considerate Service”,our business mainly focus on the distribution of electronic components. Line cards we deal with include Microchip,ALPS,ROHM,Xilinx,Pulse,ON,Everlight and Freescale. Main products comprise IC,Modules,Potentiometer,IC Socket,Relay,Connector.Our parts cover such applications as commercial,industrial, and automotives areas.

We are looking forward to setting up business relationship with you and hope to provide you with the best service and solution. Let us make a better world for our industry!



## Contact us

Tel: +86-755-8981 8866 Fax: +86-755-8427 6832

Email & Skype: info@chipsmall.com Web: www.chipsmall.com

Address: A1208, Overseas Decoration Building, #122 Zhenhua RD., Futian, Shenzhen, China



# CERAMICS SMD ULTRA MINIATURE QUARTZ CRYSTAL



ABM11

2.0 x 1.6 x 0.59mm

ABM11

RoHS/RoHS II Compliant

Moisture Sensitivity Level (MSL) – This product is Hermetically Sealed and not Moisture Sensitive - MSL = N/A: Not Applicable

## FEATURES:

- 2.0 x 1.6 x 0.59mm ultra miniature package.
- Suitable for RoHS compliant reflow.
- Seam sealed ceramic package with metal lid assures high precision and reliability.

## APPLICATIONS:

- Cellular telephones, Pagers.
- Communication and Test equipment.
- High Density applications
- PCMCIA and wireless applications.

## STANDARD SPECIFICATIONS:

Parameters	Minimum	Typical	Maximum	Units	Notes
Frequency Range	16.000		50.000	MHz	
Operation Mode	Fundamental				
Operating Temperature	-10		+60	°C	See options
Storage Temperature	-40		+85	°C	
Frequency Tolerance @+25°C	-30		+30	ppm	See options
Frequency Stability over the Operating Temperature ( ref. to +25°C)	-50		+50	ppm	See options
Equivalent series resistance (R1)			150	Ω	16.000~17.999MHz
			120		18.000~20.999MHz
			100		21.000~29.999 MHz
			80		30.000~37.999 MHz
			60		38.000~50.000 MHz
Shunt capacitance (C0)			7.0	pF	
Load capacitance (CL)	10			pF	Standard (See options if other than STD)
Drive Level		10	100	μW	
Aging	-5		+5	ppm	@25°C±3°C First year
Insulation Resistance	500			MΩ	@ 100Vdc ± 15V

## OPTIONS AND PART IDENTIFICATION: (Left blank if standard)

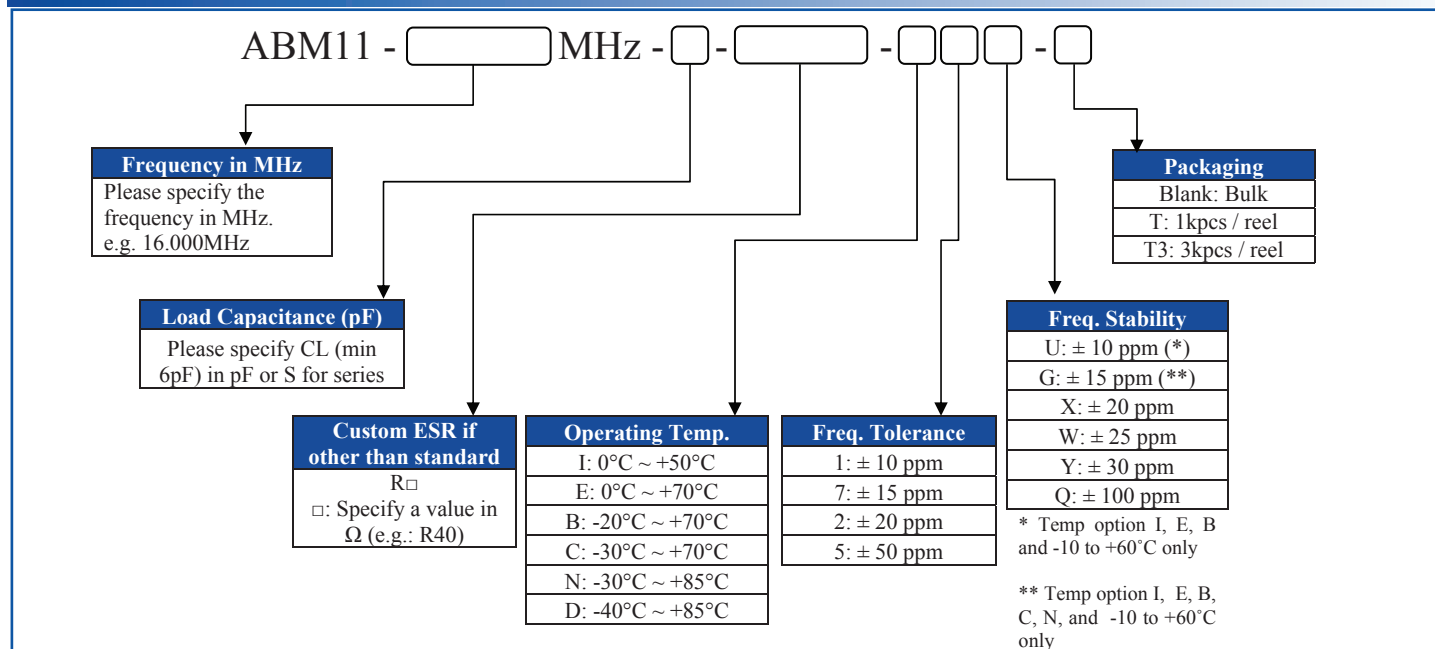

# CERAMICS SMD ULTRA MINIATURE QUARTZ CRYSTAL



ABM11

2.0 x 1.6 x 0.59mm

ABM11

RoHS/RoHS II Compliant

## OUTLINE DRAWING:

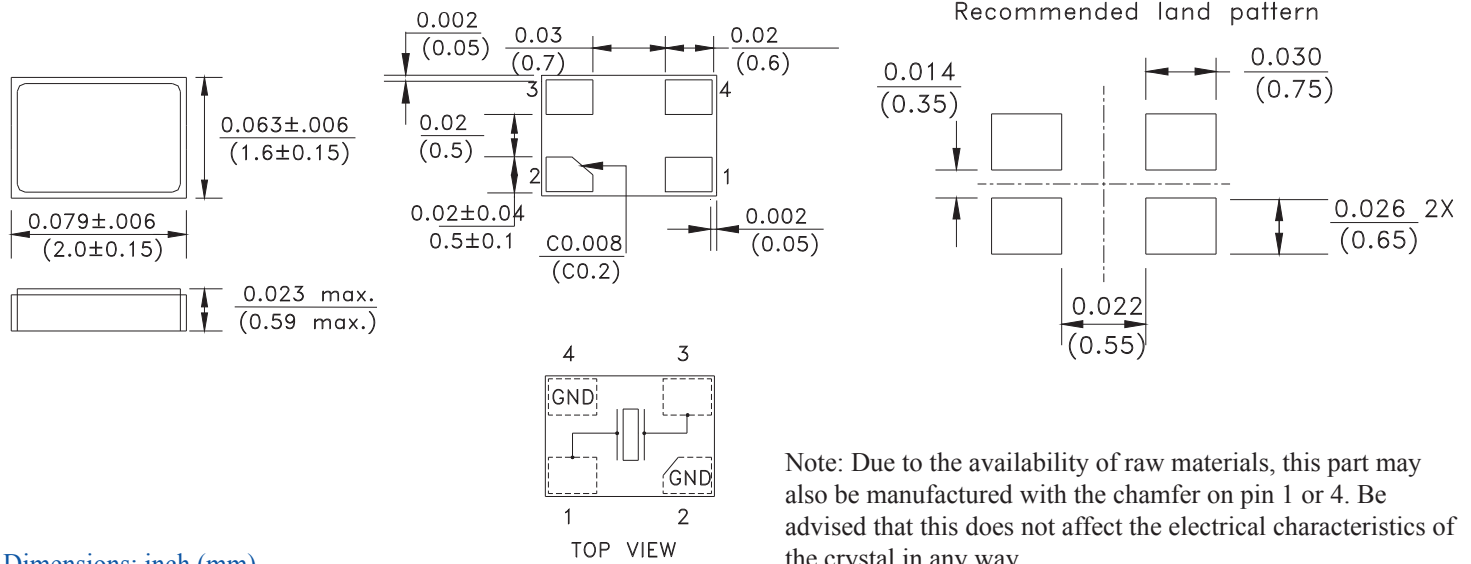

## TAPE & REEL:

Option "-T": Tape and reel (1,000pcs/reel)  
 Option "-T3": Tape and reel (3,000pcs/reel)

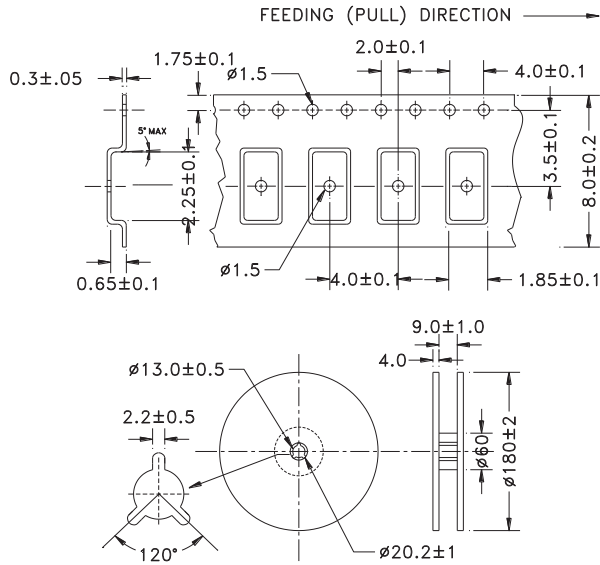

## REFLOW PROFILE:

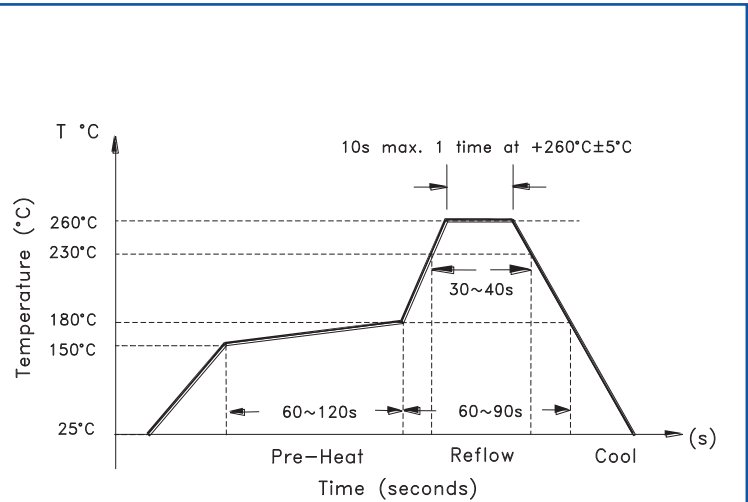

Need a test socket for the ABM11 Series? To view compatible **PRECISION TEST & BURN-IN SOCKETS** for these parts, [click here](#). P/N AXS-2016-04-04C

**ATTENTION:** Abracon Corporation's products are COTS – Commercial-Off-The-Shelf products; suitable for Commercial, Industrial and, where designated, Automotive Applications. Abracon's products are not specifically designed for Military, Aviation, Aerospace, Life-dependant Medical applications or any application requiring high reliability where component failure could result in loss of life and/or property. For applications requiring high reliability and/or presenting an extreme operating environment, written consent and authorization from Abracon Corporation is required. Please contact Abracon Corporation for more information.

ABRACON IS  
 ISO 9001: 2008  
 CERTIFIED



2 Faraday, Suite# B | Irvine | CA 92618 Revised: 06.19.15  
 Ph. 949.546.8000 | Fax. 949.546.8001  
 Visit [www.abracon.com](http://www.abracon.com) for Terms and Conditions of Sale