



Chipsmall Limited consists of a professional team with an average of over 10 year of expertise in the distribution of electronic components. Based in Hongkong, we have already established firm and mutual-benefit business relationships with customers from,Europe,America and south Asia,supplying obsolete and hard-to-find components to meet their specific needs.

With the principle of "Quality Parts,Customers Priority,Honest Operation,and Considerate Service",our business mainly focus on the distribution of electronic components. Line cards we deal with include Microchip,ALPS,ROHM,Xilinx,Pulse,ON,Everlight and Freescale. Main products comprise IC,Modules,Potentiometer,IC Socket,Relay,Connector.Our parts cover such applications as commercial,industrial, and automotives areas.

We are looking forward to setting up business relationship with you and hope to provide you with the best service and solution. Let us make a better world for our industry!



## Contact us

Tel: +86-755-8981 8866 Fax: +86-755-8427 6832

Email & Skype: info@chipsmall.com Web: www.chipsmall.com

Address: A1208, Overseas Decoration Building, #122 Zhenhua RD., Futian, Shenzhen, China



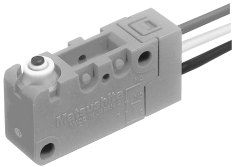

## FEATURES

- Miniature size (33×15.9×10.3 mm) (1.299×.626×.406 inch)
- Sealed construction for use in adverse environment—Sealed construction by epoxy resin and rubber cap keeps off the cause of miscontact such as dust Conforming to IP67\* of IEC protective construction classification
- Elastomer double molding technology, an industry first and ultrasonic swaging technology contribute to uniform seling in high production quantities
- UL/CSA/VDE/SEMKO approved

\*Based on the protective construction classification of IED, items which satisfy the test requirements are denoted with an IP designation.

## TYPICAL APPLICATIONS

- Automotives
- Agricultural devices
- Industrial equipment

## ORDERING INFORMATION

Ex. ABV1 2 1 0 6 1

Type of switch	Terminal	Contact arrangement	Actuator	Operating force by pin plunger (max.)	Contact
ABV1: Turquoise switch V type	2: .187 quick-connect terminal 6: Wire leads	1: SPDT 2: SPST-NC 3: SPST-NO	0: Pin plunger 2: Hinge lever 4: Simulated roller lever 5: Short roller lever 6: Roller lever	4: 0.98 N {100 gf} 5: 1.96 N {200 gf} 6: 2.94 N {300 gf}	1: Gold-clad 0: Silver-alloy

Remarks: 1. Standard packing: Dust protected type 50 pcs./carton, 500 pcs./case; Immersion protected type 50 pcs./case.  
2. Not every combination is available. Please refer to the following table, "PRODUCT TYPES".

## CONSTRUCTION

.187 quick-connect terminal

Wire leads

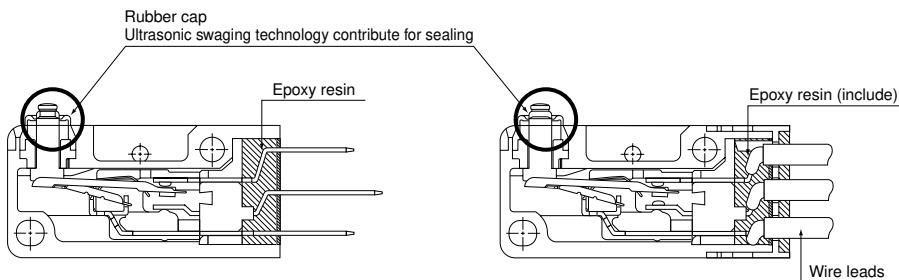

**PRODUCT TYPES**

**Silver-alloy**

Contact	Actuator	Contact Arrangement	Operating force, Max.	187 Quick-connect terminal	Wire Leads
Silver-alloy	Pin plunger	SPDT	0.98 N {100 gf}	ABV121040	ABV161040
			1.96 N {200 gf}	ABV121050	ABV161050
			2.94 N {300 gf}	ABV121060	ABV161060
		SPST-NC	0.98 N {100 gf}	ABV122040	ABV162040
			1.96 N {200 gf}	ABV122050	ABV162050
			2.94 N {300 gf}	ABV122060	ABV162060
		SPST-NO	0.98 N {100 gf}	ABV123040	ABV163040
			1.96 N {200 gf}	ABV123050	ABV163050
			2.94 N {300 gf}	ABV123060	ABV163060
	Hinge lever	SPDT	0.59 N {60 gf}	ABV121240	ABV161240
			1.18 N {120 gf}	ABV121250	ABV161250
			1.77 N {180 gf}	ABV121260	ABV161260
		SPST-NC	0.59 N {60 gf}	ABV122240	ABV162240
			1.18 N {120 gf}	ABV122250	ABV162250
			1.77 N {180 gf}	ABV122260	ABV162260
		SPST-NO	0.59 N {60 gf}	ABV123240	ABV163240
			1.18 N {120 gf}	ABV123250	ABV163250
			1.77 N {180 gf}	ABV123260	ABV163260
	Simulated roller lever	SPDT	0.59 N {60 gf}	ABV121440	ABV161440
			1.18 N {120 gf}	ABV121450	ABV161450
			1.77 N {180 gf}	ABV121460	ABV161460
		SPST-NC	0.59 N {60 gf}	ABV122440	ABV162440
			1.18 N {120 gf}	ABV122450	ABV162450
			1.77 N {180 gf}	ABV122460	ABV162460
		SPST-NO	0.59 N {60 gf}	ABV123440	ABV163440
			1.18 N {120 gf}	ABV123450	ABV163450
			1.77 N {180 gf}	ABV123460	ABV163460
	Short roller lever	SPDT	1.08 N {110 gf}	ABV121540	ABV161540
			2.16 N {220 gf}	ABV121550	ABV161550
			3.14 N {320 gf}	ABV121560	ABV161560
		SPST-NC	1.08 N {110 gf}	ABV122540	ABV162540
			2.16 N {220 gf}	ABV122550	ABV162550
			3.14 N {320 gf}	ABV122560	ABV162560
		SPST-NO	1.08 N {110 gf}	ABV123540	ABV163540
			2.16 N {220 gf}	ABV123550	ABV163550
			3.14 N {320 gf}	ABV123560	ABV163560
Roller lever	SPDT	0.59 N {60 gf}	ABV121640	ABV161640	
		1.18 N {120 gf}	ABV121650	ABV161650	
		1.77 N {180 gf}	ABV121660	ABV161660	
	SPST-NC	0.59 N {60 gf}	ABV122640	ABV162640	
		1.18 N {120 gf}	ABV122650	ABV162650	
		1.77 N {180 gf}	ABV122660	ABV162660	
	SPST-NO	0.59 N {60 gf}	ABV123640	ABV163640	
		1.18 N {120 gf}	ABV123650	ABV163650	
		1.77 N {180 gf}	ABV136660	ABV163660	

Remarks: When ordering UL/CSA approved types, please attach suffix "9" to the part number.  
 When ordering VDE/SEMKO approved types, please attach suffix "8" to the part number.

# ABV1

## Gold-clad

Contact	Actuator	Contact Arrangement	Operating force, Max.	187 Quick-connect terminal	Wire Leads
Gold-clad	Pin plunger	SPDT	0.98 N {100 gf}	ABV121041	ABV161041
			1.96 N {200 gf}	ABV121051	ABV161051
			2.94 N {300 gf}	ABV121061	ABV161061
		SPST-NC	0.98 N {100 gf}	ABV122041	ABV162041
			1.96 N {200 gf}	ABV122051	ABV162051
			2.94 N {300 gf}	ABV122061	ABV162061
		SPST-NO	0.98 N {100 gf}	ABV123041	ABV163041
			1.96 N {200 gf}	ABV123051	ABV163051
			2.94 N {300 gf}	ABV123061	ABV163061
	Hinge lever	SPDT	0.59 N {60 gf}	ABV121241	ABV161241
			1.18 N {120 gf}	ABV121251	ABV161251
			1.77 N {180 gf}	ABV121261	ABV161261
		SPST-NC	0.59 N {60 gf}	ABV122241	ABV162241
			1.18 N {120 gf}	ABV122251	ABV162251
			1.77 N {180 gf}	ABV122261	ABV162261
		SPST-NO	0.59 N {60 gf}	ABV123241	ABV163241
			1.18 N {120 gf}	ABV123251	ABV163251
			1.77 N {180 gf}	ABV123261	ABV163261
	Simulated roller lever	SPDT	0.59 N {60 gf}	ABV121441	ABV161441
			1.18 N {120 gf}	ABV121451	ABV161451
			1.77 N {180 gf}	ABV121461	ABV161461
		SPST-NC	0.59 N {60 gf}	ABV122441	ABV162441
			1.18 N {120 gf}	ABV122451	ABV162451
			1.77 N {180 gf}	ABV122461	ABV162461
		SPST-NO	0.59 N {60 gf}	ABV123441	ABV163441
			1.18 N {120 gf}	ABV123451	ABV163451
			1.77 N {180 gf}	ABV123461	ABV163461
	Short roller lever	SPDT	1.08 N {110 gf}	ABV121541	ABV161541
			2.16 N {220 gf}	ABV121551	ABV161551
			3.14 N {320 gf}	ABV121561	ABV161561
		SPST-NC	1.08 N {110 gf}	ABV122541	ABV162541
			2.16 N {220 gf}	ABV122551	ABV162551
			3.14 N {320 gf}	ABV122561	ABV162561
		SPST-NO	1.08 N {110 gf}	ABV123541	ABV163541
			2.16 N {220 gf}	ABV123551	ABV163551
			3.14 N {320 gf}	ABV123561	ABV163561
	Roller lever	SPDT	0.59 N {60 gf}	ABV121641	ABV161641
			1.18 N {120 gf}	ABV121651	ABV161651
			1.77 N {180 gf}	ABV121661	ABV161661
		SPST-NC	0.59 N {60 gf}	ABV122641	ABV162641
			1.18 N {120 gf}	ABV122651	ABV162651
			1.77 N {180 gf}	ABV122661	ABV162661
SPST-NO		0.59 N {60 gf}	ABV123641	ABV163641	
		1.18 N {120 gf}	ABV123651	ABV163651	
		1.77 N {180 gf}	ABV136661	ABV163661	

Remarks: When ordering UL/CSA approved types, please attach suffix "9" to the part number.  
 When ordering VDE/SEMKO approved types, please attach suffix "8" to the part number.

# SPECIFICATIONS

## 1. Contact rating

Type	Standard rating	Low-level rating
Gold-clad contact	3 A 250 V AC (O.F. 1.96 N {200gf}, 2.94 N {300gf}) 1 A 250 V AC (O.F. 0.98 N {100gf})	5 mA 6 V DC 2 mA 12 V DC 1 mA 24 V DC
Silver-alloy	5 A 250 V AC (O.F. 1.96 N {200gf}, 2.94 N {300gf}) 3 A 250 V AC (O.F. 0.98 N {100gf})	—

## 2. Characteristics

Mechanical life (O.T.: Specified value)	Min. 5x10 <sup>6</sup> (at 60 cpm)	
Electrical life	Nominal rating (O.T.: Max.)	Min. 10 <sup>5</sup> (at 20 cpm)
	Low-level rating (O.T.: Specified value)	Min. 10 <sup>6</sup> (at 20 cpm)
Insulation resistance	Min. 100 MΩ (at 500 V DC insulation resistance meter)	
Dielectric strength	1,000 Vrms	
Between non-continuous terminals	2,000 Vrms	
Between each terminal and other exposed metal parts	2,000 Vrms	
Between each terminal and ground	2,000 Vrms	
Vibration resistance	10 to 55 Hz at single amplitude of 0.75 mm (Contact opening: max. 1 msec.)	
Shock resistance	Min. 294 m/s <sup>2</sup> {30 G} (Contact opening: Max. 1 msec.)	
Contact resistance	Silver alloy contact type	Dust protected type (IP50): Max. 50 mΩ Immersion protected type (IP67): Max. 100 mΩ (By voltage drop 1 A 6 to 8 V DC)
	Gold-clad contact type	Dust protected type (IP50): Max. 50 mΩ Immersion protected type (IP67): Max. 100 mΩ (By voltage drop 0.1 A 6 to 8 V DC)
Allowable operating speed (at no load)	1 to 500 mm/sec.	
Ambient temperature (at no load)	-40°C to +85°C -40°F to +185°F	
Unit weight	Approx. 7 g .247 oz (IP50 type)	

## 3. Operating characteristics

Type of actuator	Operating force, Max.			Release force, Min.			Pretravel, Max. mm inch	Movement differential, Max. mm inch	Overtravel, Min. mm inch	Operating position, mm inch
	2.94N {300gf}	1.96N {200gf}	0.98N {100gf}	0.59N {60gf}	0.39N {40gf}	0.25N {25gf}				
Pin plunger	2.94N {300gf}	1.96N {200gf}	0.98N {100gf}	0.59N {60gf}	0.39N {40gf}	0.25N {25gf}	1.6 .063	0.4 .016	0.8 .031	14.7±0.6 .579 ± .024
Hinge lever	1.77N {180gf}	1.18N {120gf}	0.59N {60gf}	0.20N {20gf}	0.13N {13gf}	0.098N {10gf}	3.2 .126	1.2 .047	1.2 .047	15.3±1.2 .602 ± .047
Simulated roller lever	1.77N {180gf}	1.18N {120gf}	0.59N {60gf}	0.20N {20gf}	0.13N {13gf}	0.098N {10gf}	3.2 .126	1.2 .047	1.2 .047	18.5±1.2 .728 ± .047
Short roller lever	3.14N {320gf}	2.16N {220gf}	1.08N {110gf}	0.59N {60gf}	0.39N {40gf}	0.20N {20gf}	1.6 .063	0.5 .020	0.8 .031	20.7±0.8 .815 ± .031
Roller lever	1.77N {180gf}	1.18N {120gf}	0.59N {60gf}	0.20N {20gf}	0.13N {13gf}	0.098N {10gf}	3.2 .126	1.2 .047	1.2 .047	20.7±1.2 .815 ± .047

( ) : Low force type

# DIMENSIONS

mm inch General tolerance: ±0.4 ± .016

## 1. Dust protected type

1-(1) .187 quick-connect terminal

Pin plunger

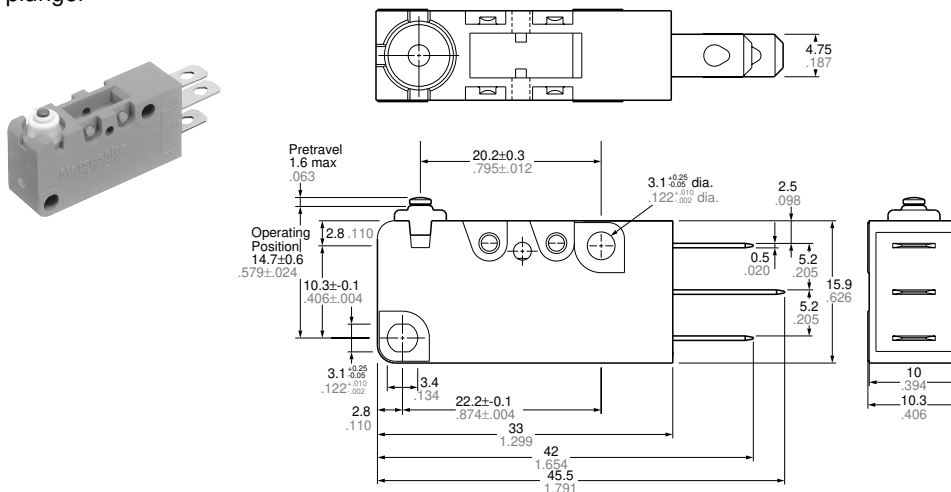

Pretravel, Max. mm inch	1.6 .063
Movement differential, Max. mm inch	0.4 .016
Overtravel, Min. mm inch	0.8 .031
Operating position, mm inch	14.7±0.6 .579 ± .024

# ABV1

## Hinge lever

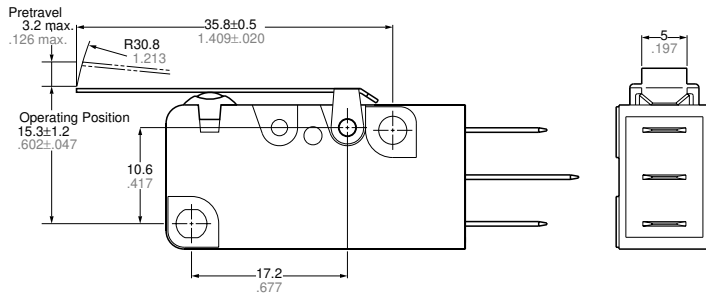

mm inch General tolerance: ±0.25 ± .010

Pretravel, Max. mm inch	3.2 .126
Movement differential, Max. mm inch	1.2 .047
Overtravel, Min. mm inch	1.2 .047
Operating position, mm inch	15.3±1.2 .602 ± .047

## Simulated roller lever

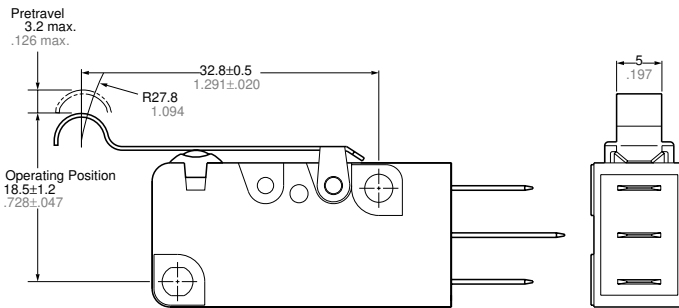

Pretravel, Max. mm inch	3.2 .126
Movement differential, Max. mm inch	1.2 .047
Overtravel, Min. mm inch	1.2 .047
Operating position, mm inch	18.5±1.2 .728 ± .047

## Short roller lever

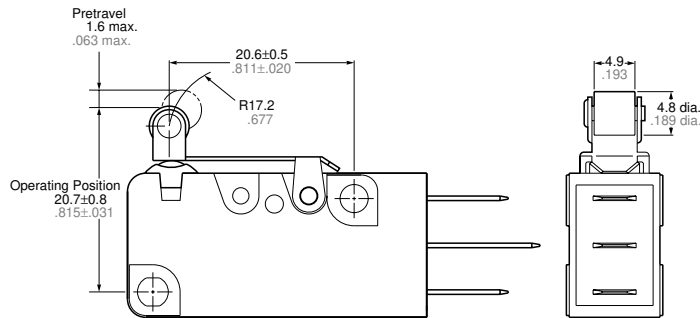
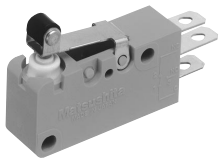

Pretravel, Max. mm inch	1.6 .063
Movement differential, Max. mm (inch)	0.5 .020
Overtravel, Min. mm (inch)	0.8 .031
Operating position, mm inch	20.7±0.8 .815 ± .031

## Roller lever

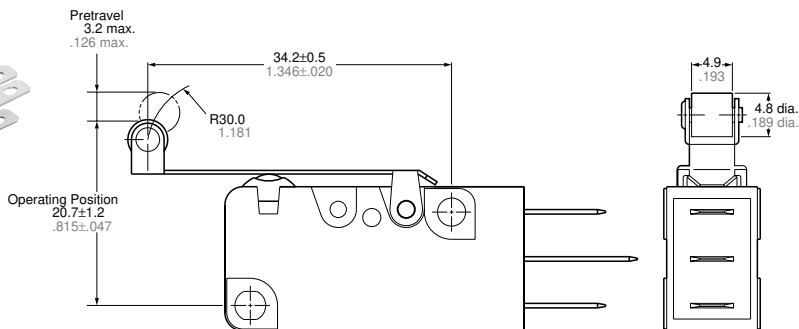

Pretravel, Max. mm inch	3.2 .126
Movement differential, Max. mm inch	1.2 .047
Overtravel, Min. mm (inch)	1.2 .047
Operating position, mm inch	20.7±1.2 .815 ± .047

## 2. Immersion protected type

### Wire Leads

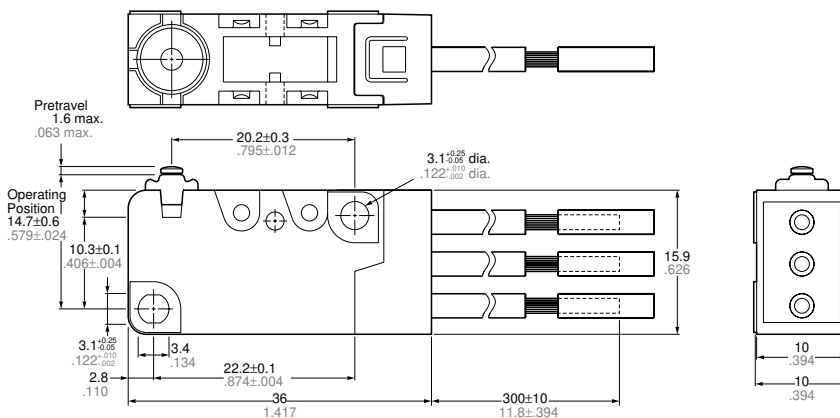
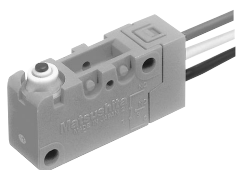

Thickness of the lead wire:  
 Standard type: 0.75mm<sup>2</sup>  
 UL/CSA approved type:  
 AWG #18  
 Color of the lead wire  
 COM ...black  
 N.C. ...red  
 N.O. ...white