



Chipsmall Limited consists of a professional team with an average of over 10 year of expertise in the distribution of electronic components. Based in Hongkong, we have already established firm and mutual-benefit business relationships with customers from,Europe,America and south Asia,supplying obsolete and hard-to-find components to meet their specific needs.

With the principle of “Quality Parts,Customers Priority,Honest Operation,and Considerate Service”,our business mainly focus on the distribution of electronic components. Line cards we deal with include Microchip,ALPS,ROHM,Xilinx,Pulse,ON,Everlight and Freescale. Main products comprise IC,Modules,Potentiometer,IC Socket,Relay,Connector.Our parts cover such applications as commercial,industrial, and automotives areas.

We are looking forward to setting up business relationship with you and hope to provide you with the best service and solution. Let us make a better world for our industry!



## Contact us

Tel: +86-755-8981 8866 Fax: +86-755-8427 6832

Email & Skype: info@chipsmall.com Web: www.chipsmall.com

Address: A1208, Overseas Decoration Building, #122 Zhenhua RD., Futian, Shenzhen, China





**MICROCHIP**

---

**CAN/LIN/J2602 PICtail™ (Plus)  
Daughter Board User's Guide**

---

**Note the following details of the code protection feature on Microchip devices:**

- Microchip products meet the specification contained in their particular Microchip Data Sheet.
- Microchip believes that its family of products is one of the most secure families of its kind on the market today, when used in the intended manner and under normal conditions.
- There are dishonest and possibly illegal methods used to breach the code protection feature. All of these methods, to our knowledge, require using the Microchip products in a manner outside the operating specifications contained in Microchip's Data Sheets. Most likely, the person doing so is engaged in theft of intellectual property.
- Microchip is willing to work with the customer who is concerned about the integrity of their code.
- Neither Microchip nor any other semiconductor manufacturer can guarantee the security of their code. Code protection does not mean that we are guaranteeing the product as "unbreakable."

Code protection is constantly evolving. We at Microchip are committed to continuously improving the code protection features of our products. Attempts to break Microchip's code protection feature may be a violation of the Digital Millennium Copyright Act. If such acts allow unauthorized access to your software or other copyrighted work, you may have a right to sue for relief under that Act.

---

Information contained in this publication regarding device applications and the like is provided only for your convenience and may be superseded by updates. It is your responsibility to ensure that your application meets with your specifications. MICROCHIP MAKES NO REPRESENTATIONS OR WARRANTIES OF ANY KIND WHETHER EXPRESS OR IMPLIED, WRITTEN OR ORAL, STATUTORY OR OTHERWISE, RELATED TO THE INFORMATION, INCLUDING BUT NOT LIMITED TO ITS CONDITION, QUALITY, PERFORMANCE, MERCHANTABILITY OR FITNESS FOR PURPOSE. Microchip disclaims all liability arising from this information and its use. Use of Microchip devices in life support and/or safety applications is entirely at the buyer's risk, and the buyer agrees to defend, indemnify and hold harmless Microchip from any and all damages, claims, suits, or expenses resulting from such use. No licenses are conveyed, implicitly or otherwise, under any Microchip intellectual property rights.

**Trademarks**

The Microchip name and logo, the Microchip logo, dsPIC, KEELOQ, KEELOQ logo, MPLAB, PIC, PICmicro, PICSTART, PIC<sup>32</sup> logo, rfPIC and UNI/O are registered trademarks of Microchip Technology Incorporated in the U.S.A. and other countries.

FilterLab, Hampshire, HI-TECH C, Linear Active Thermistor, MXDEV, MXLAB, SEEVAL and The Embedded Control Solutions Company are registered trademarks of Microchip Technology Incorporated in the U.S.A.

Analog-for-the-Digital Age, Application Maestro, CodeGuard, dsPICDEM, dsPICDEM.net, dsPICworks, dsSPEAK, ECAN, ECONOMONITOR, FanSense, HI-TIDE, In-Circuit Serial Programming, ICSP, Mindi, MiWi, MPASM, MPLAB Certified logo, MPLIB, MPLINK, mTouch, Omniscient Code Generation, PICC, PICC-18, PICDEM, PICDEM.net, PICKit, PICtail, REAL ICE, rFLAB, Select Mode, Total Endurance, TSHARC, UniWinDriver, WiperLock and ZENA are trademarks of Microchip Technology Incorporated in the U.S.A. and other countries.

SQTP is a service mark of Microchip Technology Incorporated in the U.S.A.

All other trademarks mentioned herein are property of their respective companies.

© 2011, Microchip Technology Incorporated, Printed in the U.S.A., All Rights Reserved.

 Printed on recycled paper.

ISBN: 978-1-60932-934-1

*Microchip received ISO/TS-16949:2002 certification for its worldwide headquarters, design and wafer fabrication facilities in Chandler and Tempe, Arizona; Gresham, Oregon and design centers in California and India. The Company's quality system processes and procedures are for its PIC<sup>®</sup> MCUs and dsPIC<sup>®</sup> DSCs, KEELOQ<sup>®</sup> code hopping devices, Serial EEPROMs, microperipherals, nonvolatile memory and analog products. In addition, Microchip's quality system for the design and manufacture of development systems is ISO 9001:2000 certified.*

**QUALITY MANAGEMENT SYSTEM  
CERTIFIED BY DNV  
== ISO/TS 16949:2002 ==**



# CAN/LIN/J2602 PICtail™ (Plus) DAUGHTER BOARD USER'S GUIDE

---

---

## Table of Contents

---

---

<b>Preface</b> .....	<b>5</b>
<b>Chapter 1. Introduction</b>	
1.1 Overview .....	11
1.2 Functional Overview .....	13
<b>Chapter 2. Hardware</b>	
2.1 Board Setup .....	15
2.2 Hardware Components .....	16
2.3 Auxiliary Header Pinouts .....	19
<b>Chapter 3. CAN/LIN/J2602 PICtail (Plus) Daughter Board Tutorial Program</b>	
3.1 PIC18 Tutorial Overview .....	21
3.2 dsPIC33F and PIC24H Tutorial Overview .....	22
<b>Appendix A. Drawings and Schematics</b>	
A.1 CAN/LIN/J2602 PICtail™ (Plus) Daughter Board Layout .....	23
A.2 Schematic Diagrams .....	24
<b>Index</b> .....	<b>31</b>
<b>Worldwide Sales and Service</b> .....	<b>32</b>

# CAN/LIN/J2602 PICtail™ (Plus) Daughter Board User's Guide

---

---

NOTES:



# CAN/LIN/J2602 PICtail™ (Plus) DAUGHTER BOARD USER'S GUIDE

## Preface

### NOTICE TO CUSTOMERS

All documentation becomes dated, and this manual is no exception. Microchip tools and documentation are constantly evolving to meet customer needs, so some actual dialogs and/or tool descriptions may differ from those in this document. Please refer to our web site ([www.microchip.com](http://www.microchip.com)) to obtain the latest documentation available.

Documents are identified with a “DS” number. This number is located on the bottom of each page, in front of the page number. The numbering convention for the DS number is “DSXXXXA”, where “XXXX” is the document number and “A” is the revision level of the document.

For the most up-to-date information on development tools, see the MPLAB® IDE on-line help. Select the Help menu, and then Topics to open a list of available online help files.

## INTRODUCTION

This chapter contains general information that will be useful to know before using the CAN/LIN/J2602 PICtail™ (Plus) Daughter Board. Items discussed in this chapter include:

- Document Layout
- Conventions Used in this Guide
- Warranty Registration
- Recommended Reading
- The Microchip Web Site
- Development Systems Customer Change Notification Service
- Customer Support
- Document Revision History

## DOCUMENT LAYOUT

This document describes how to use the CAN/LIN/J2602 PICtail™ (Plus) Daughter Board as a development tool to emulate and debug firmware on a target board. The manual layout is as follows:

- **Chapter 1. Introduction** – This chapter introduces the CAN/LIN/J2602 PICtail (Plus) Daughter Board and provides an overview of its features.
- **Chapter 2. Hardware** – This chapter provides a functional overview of the CAN/LIN/J2602 PICtail (Plus) Daughter Board and identifies the major hardware components.
- **Appendix A. Drawings and Schematics** – This appendix provides detailed technical drawings and schematic diagrams of the CAN/LIN/J2602 PICtail (Plus) Daughter Board.

# CAN/LIN/J2602 PICtail™ (Plus) Daughter Board User's Guide

## CONVENTIONS USED IN THIS GUIDE

This manual uses the following documentation conventions:

### DOCUMENTATION CONVENTIONS

Description	Represents	Examples
<b>Arial font:</b>		
Italic characters	Referenced books	<i>MPLAB® IDE User's Guide</i>
	Emphasized text	...is the <i>only</i> compiler...
Initial caps	A window	the Output window
	A dialog	the Settings dialog
	A menu selection	select Enable Programmer
Quotes	A field name in a window or dialog	"Save project before build"
Underlined, italic text with right angle bracket	A menu path	<u>File</u> > <i>Save</i>
Bold characters	A dialog button	Click <b>OK</b>
	A tab	Click the <b>Power</b> tab
N'Rnnnn	A number in verilog format, where N is the total number of digits, R is the radix and n is a digit.	4'b0010, 2'hF1
Text in angle brackets < >	A key on the keyboard	Press <Enter>, <F1>
<b>Courier New font:</b>		
Plain Courier New	Sample source code	#define START
	Filenames	autoexec.bat
	File paths	c:\mcc18\h
	Keywords	_asm, _endasm, static
	Command-line options	-Opa+, -Opa-
	Bit values	0, 1
	Constants	0xFF, 'A'
Italic Courier New	A variable argument	<i>file.o</i> , where <i>file</i> can be any valid filename
Square brackets [ ]	Optional arguments	mcc18 [options] <i>file</i> [options]
Curly brackets and pipe character: {   }	Choice of mutually exclusive arguments; an OR selection	errorlevel {0 1}
Ellipses...	Replaces repeated text	var_name [, var_name...]
	Represents code supplied by user	void main (void) { ... }

## WARRANTY REGISTRATION

Please complete the enclosed Warranty Registration Card and mail it promptly. Sending in the Warranty Registration Card entitles users to receive new product updates. Interim software releases are available at the Microchip web site.

## RECOMMENDED READING

This user's guide describes how to use CAN/LIN/J2602 PICtail (Plus) Daughter Board. Other useful documents are listed below. Microchip documents are available and recommended as supplemental reference resources.

### Device Data Sheets

Refer to the data sheet for the specific dsPIC33F or PIC24 device you are using. Specifically, refer to the sections in these data sheets that provide detailed information on the device UART and ECAN modules.

### Readme Files

For the latest information on using other tools, read the tool-specific Readme files in the Readmes subdirectory of the MPLAB® IDE installation directory. The Readme files contain update information and known issues that may not be included in this user's guide.

## THE MICROCHIP WEB SITE

Microchip provides online support via our web site at [www.microchip.com](http://www.microchip.com). This web site is used as a means to make files and information easily available to customers. Accessible by using your favorite Internet browser, the web site contains the following information:

- **Product Support** – Data sheets and errata, application notes and sample programs, design resources, user's guides and hardware support documents, latest software releases and archived software
- **General Technical Support** – Frequently Asked Questions (FAQs), technical support requests, online discussion groups, Microchip consultant program member listing
- **Business of Microchip** – Product selector and ordering guides, latest Microchip press releases, listing of seminars and events, listings of Microchip sales offices, distributors and factory representatives

## DEVELOPMENT SYSTEMS CUSTOMER CHANGE NOTIFICATION SERVICE

Microchip's customer notification service helps keep customers current on Microchip products. Subscribers will receive e-mail notification whenever there are changes, updates, revisions or errata related to a specified product family or development tool of interest.

To register, access the Microchip web site at [www.microchip.com](http://www.microchip.com), click on Customer Change Notification and follow the registration instructions.

The Development Systems product group categories are:

- **Compilers** – The latest information on Microchip C compilers and other language tools. These include the MPLAB C18 and MPLAB C30 C compilers; MPASM™ and MPLAB ASM30 assemblers; MPLINK™ and MPLAB LINK30 object linkers; and MPLIB™ and MPLAB LIB30 object librarians.
- **Emulators** – The latest information on Microchip in-circuit emulators. This includes the MPLAB ICE 2000 and MPLAB ICE 4000.
- **In-Circuit Debuggers** – The latest information on the Microchip in-circuit debugger, MPLAB ICD 2.
- **MPLAB® IDE** – The latest information on Microchip MPLAB IDE, the Windows® Integrated Development Environment for development systems tools. This list is focused on the MPLAB IDE, MPLAB SIM simulator, MPLAB IDE Project Manager and general editing and debugging features.
- **Programmers** – The latest information on Microchip programmers. These include the MPLAB PM3 and PRO MATE® II device programmers and the PICSTART® Plus and PICKit™ 1 development programmers.

## CUSTOMER SUPPORT

Users of Microchip products can receive assistance through several channels:

- Distributor or Representative
- Local Sales Office
- Field Application Engineer (FAE)
- Technical Support

Customers should contact their distributor, representative or field application engineer (FAE) for support. Local sales offices are also available to help customers. A listing of sales offices and locations is included in the back of this document.

Technical support is available through the web site at: <http://support.microchip.com>

# CAN/LIN/J2602 PICtail™ (Plus) Daughter Board User's Guide

---

---

## DOCUMENT REVISION HISTORY

### **Revision A (January 2008)**

- Initial Release of this Document.

### **Revision B (March 2011)**

- Added support for PIC18 Explorer Development Board.

---

---

## Chapter 1. Introduction

---

---

Thank you for purchasing Microchip Technology's CAN/LIN/J2602 PICtail™ (Plus) Daughter Board. This board is compatible with both the Explorer 16 Development Board and the PIC18 Explorer Board to facilitate rapid implementation and evaluation of applications that use Controller Area Network (CAN) and Local Interconnect Network (LIN) interfaces and are implemented on dsPIC33F Digital Signal Controllers, PIC24 16-bit microcontrollers and PIC18 8-bit microcontrollers.

This chapter introduces the CAN/LIN/J2602 PICtail™ (Plus) Daughter Board and provides an overview of its features. Topics covered include:

- Overview
- Functional Overview

### 1.1 OVERVIEW

The CAN/LIN/J2602 PICtail™ (Plus) Daughter Board augments development of dsPIC33F and PIC24 based applications on the Explorer 16 Development Board and augments development of PIC18 based applications on the PIC18 Explorer Development Board. It offers two interfaces: one for a CAN bus and one for a LIN bus. Although CAN and LIN protocols are used most extensively in automotive applications, the CAN/LIN/J2602 PICtail™ (Plus) Daughter Board can be used in any application that requires interfacing to a CAN and LIN bus.

Both interfaces can be used simultaneously. Appropriate bus transceivers on the CAN/LIN/J2602 PICtail™ (Plus) Daughter Board complete the physical layer requirements of the CAN and LIN bus protocols. In both cases, communication is driven by the dsPIC33F, PIC24 or PIC18 device on its respective development board.

Figure 1-1 shows the CAN/LIN/J2602 PICtail™ (Plus) Daughter Board plugged into the PICtail Plus slot on the Explorer 16 Development Board, and Figure 1-2 shows the CAN/LIN/J2602 PICtail™ (Plus) Daughter Board plugged into the PICtail slot on the PIC18 Explorer Development Board. The CAN/LIN/J2602 PICtail™ (Plus) Daughter Board draws 9V, 5V and 3.3V DC power from the connected development board. The external power supply and MPLAB ICD 3 are plugged into the development board.

# CAN/LIN/J2602 PICtail™ (Plus) Daughter Board User's Guide

**FIGURE 1-1: CAN/LIN/J2602 PICtail™ (Plus) DAUGHTER BOARD CONNECTED TO EXPLORER 16 DEVELOPMENT BOARD**

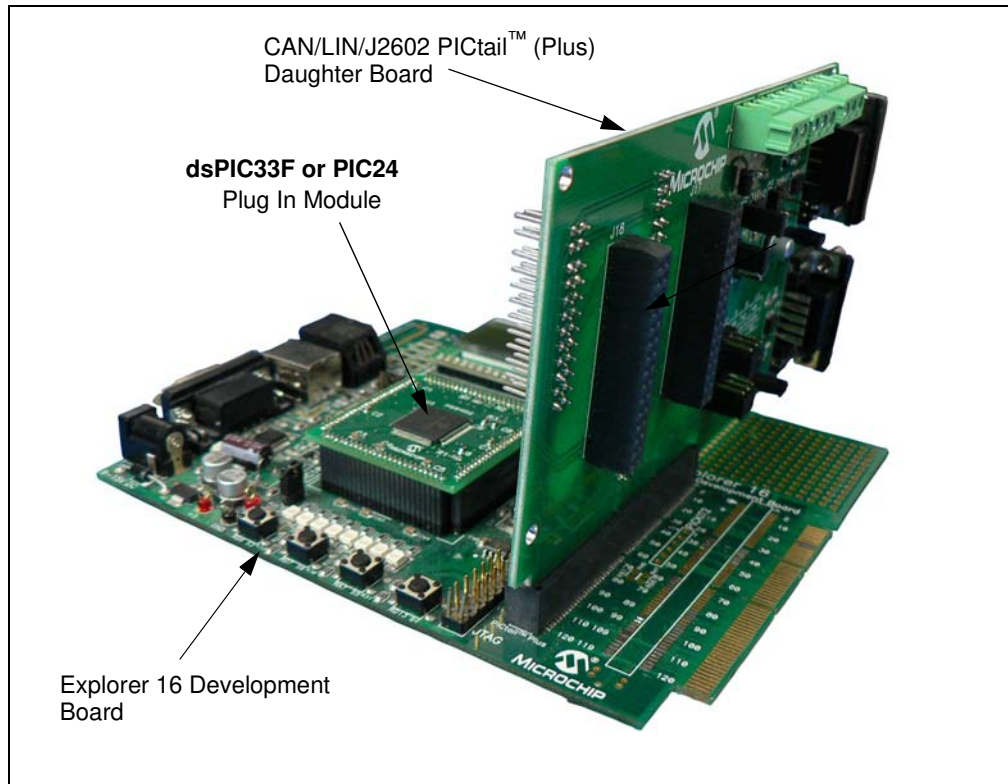

**FIGURE 1-2: CAN/LIN/J2602 PICtail™ (Plus) DAUGHTER BOARD CONNECTED TO PIC18 EXPLORER DEVELOPMENT BOARD**

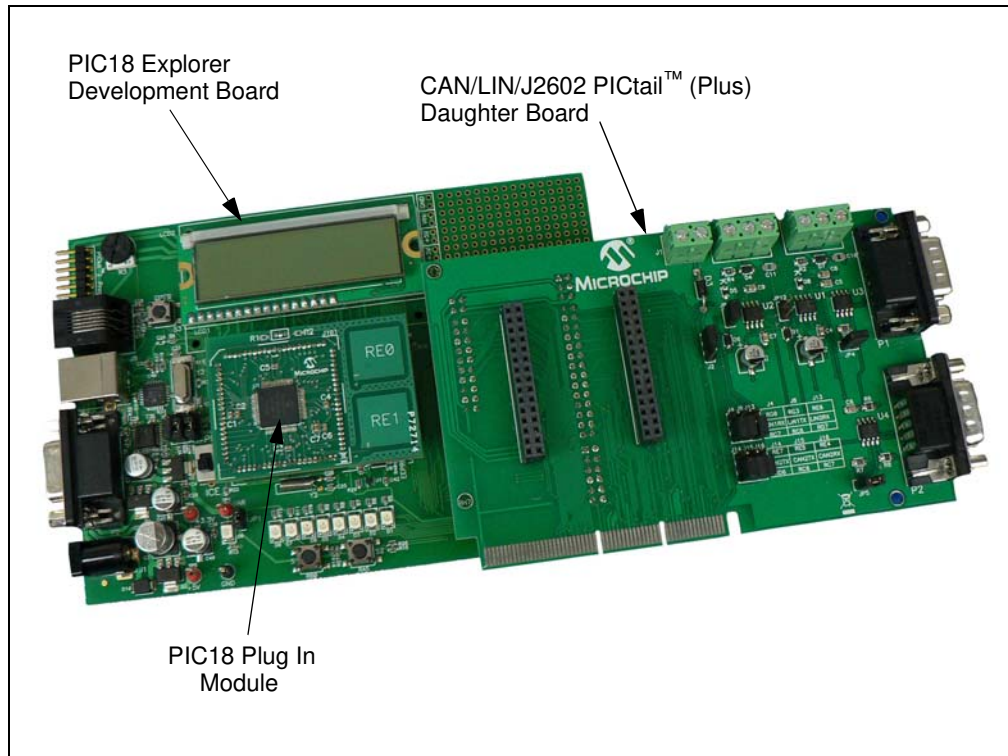

## 1.2 FUNCTIONAL OVERVIEW

The block diagram shown in Figure 1-3 illustrates the mainstream operation of the CAN/LIN/J2602 PICtail™ (Plus) Daughter Board. The board contains two LIN signal conditioning circuits and two CAN signal conditioning circuits. The board also enables power to be provided by the development board it is connected to, or by an external 12V DC source.

**FIGURE 1-3: CAN/LIN/J2602 PICtail™ (Plus) DAUGHTER BOARD BLOCK DIAGRAM**

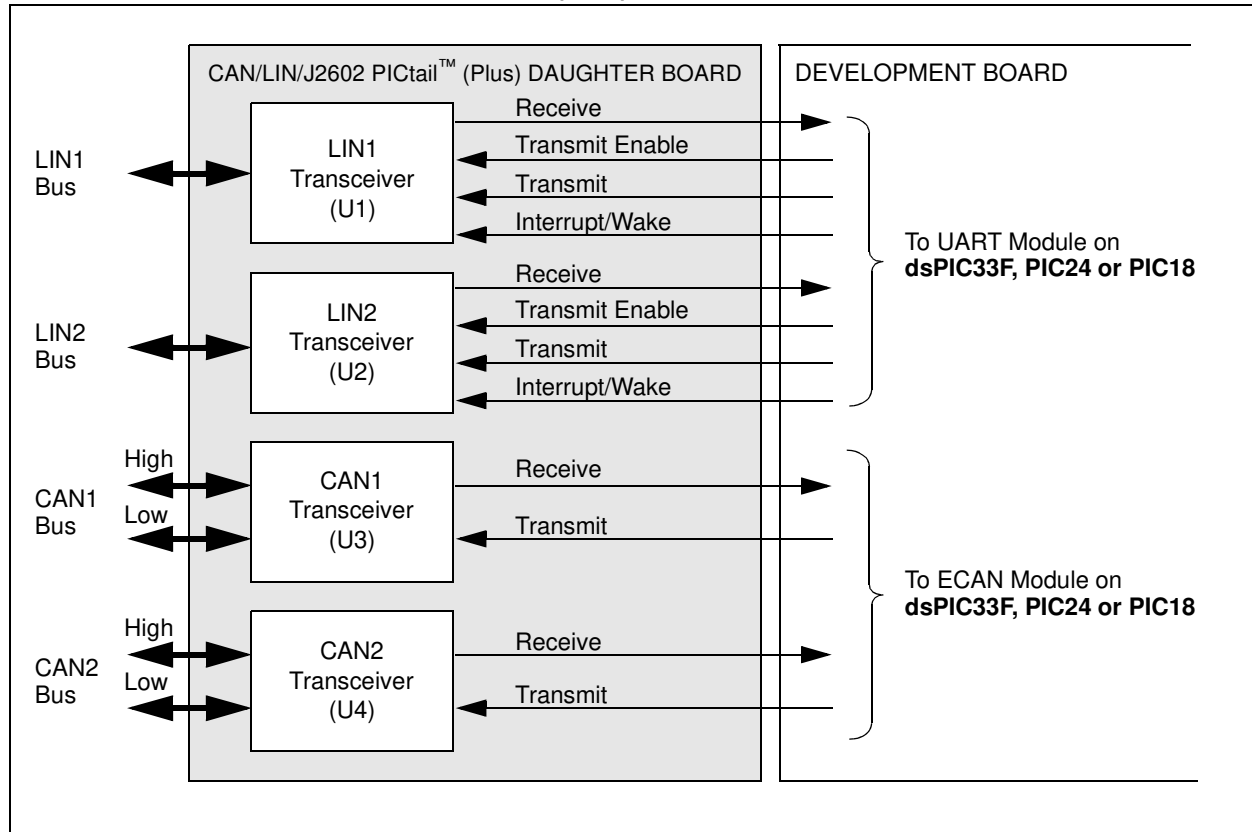

### 1.2.1 LIN Operation

The CAN/LIN/J2602 PICtail™ (Plus) Daughter Board connects two LIN transceivers with integrated voltage regulators to UART modules on a dsPIC33F, PIC24 or PIC18 control device on the Explorer 16 or PIC18 Explorer Board. The LIN transceiver monitors the LIN bus, conditions the incoming signal and passes it to the UART module on the control device. The LIN transceiver responds to a “Transmit Enable” from the control device by conditioning an output signal and placing it on the LIN bus.

A Power-down mode turns the transmitter and voltage regulator off, leaving only the receiver and wake-up circuits in operation. Each LIN circuit includes a Master/Slave jumper to accommodate a Master node on the LIN bus.

In order to use the transmit enable for the LIN2 transceiver with the PIC18 Explorer Board and a PIC18 device, the LIN2TXE pin must be connected to 5V, or a pin on the PIC18 device, to control it. This can be done by connecting a jumper wire on the J18 header between LIN2TXE and either the 5V supply also on the J18 header, or an available pin on either the J17 or J18 header. For more information on the J17 and J18 headers see **Section 2.3 “Auxiliary Header Pinouts”**.

For PIC18 devices, the pinout for the LIN1 and LIN2 modules can be different. The jumpers J4, J8, J13 and J14 are for choosing between these pinouts. For the specific pinout that is necessary for the PIC18 that is used, refer to that device's data sheet. For PIC24 and dsPIC33 devices, make sure to leave the J4, J8, J13 and J14 jumpers disconnected. Otherwise, these connections can disrupt LIN communications.

For detailed information on the MCP2021-500 LIN Transceiver, refer to Microchip Data Sheet MCP202X *"LIN Transceiver with Voltage Regulator"* (DS22018).

## 1.2.2 CAN Operation

The CAN/LIN/J2602 PICtail™ (Plus) Daughter Board connects two high-speed CAN transceivers to ECAN modules on the control device on the development board. The CAN transceivers convert the differential signal on the CAN bus to a digital signal for the ECAN module. It also converts the ECAN output digital signal to a differential signal for the CAN bus.

All PIC18 devices have one CAN module, which is connected to the CAN1 transceiver (U3). For some PIC18s, there is an optional alternate pinout for the CAN module that is chosen by an internal MUX. This alternate pinout is connected to the CAN2 transceiver (U4). Depending on the number of pins the device has, this alternate pinout has two options. These two options are chosen by the two jumpers (J15 and J16). For detailed information on the CAN pinout options for the PIC18, refer to that device's data sheet. Also, the alternate CAN pinout for some PIC18s is the same as the LIN1 pinout. If this is the case, LIN1 and CAN communications cannot be used simultaneously. For PIC24 and dsPIC33 devices, make sure to leave J15 and J16 disconnected. Otherwise, these connections can disrupt CAN communications.

In Sleep mode, the CAN transmitter is turned off, and the receiver operates at a lower current level. The control device monitors CAN activity and switches the transceiver back to normal operation when needed.

For detailed information on the MCP2551 High-Speed CAN Transceiver, refer to Microchip Data Sheet MCP2551 *"High-Speed CAN Transceiver"* (DS21667).

## Chapter 2. Hardware

This chapter provides a functional overview of the CAN/LIN/J2602 PICtail (Plus) Daughter Board and identifies the major hardware components. Topics covered include:

- Board Setup
- Hardware Components

### 2.1 BOARD SETUP

Figure 2-1 is a photograph of the CAN/LIN/J2602 PICtail (Plus) Daughter Board. Call-outs indicate the CAN bus, LIN bus and signal connections on the daughter board. Also shown are two 2x15 headers that provide signals from the development board. These headers can be probed for development, testing or monitoring of the application. For their specific pinouts, see **Section 2.3 “Auxiliary Header Pinouts”**.

**FIGURE 2-1: CAN/LIN/J2602 PICtail™ (Plus) DAUGHTER BOARD**

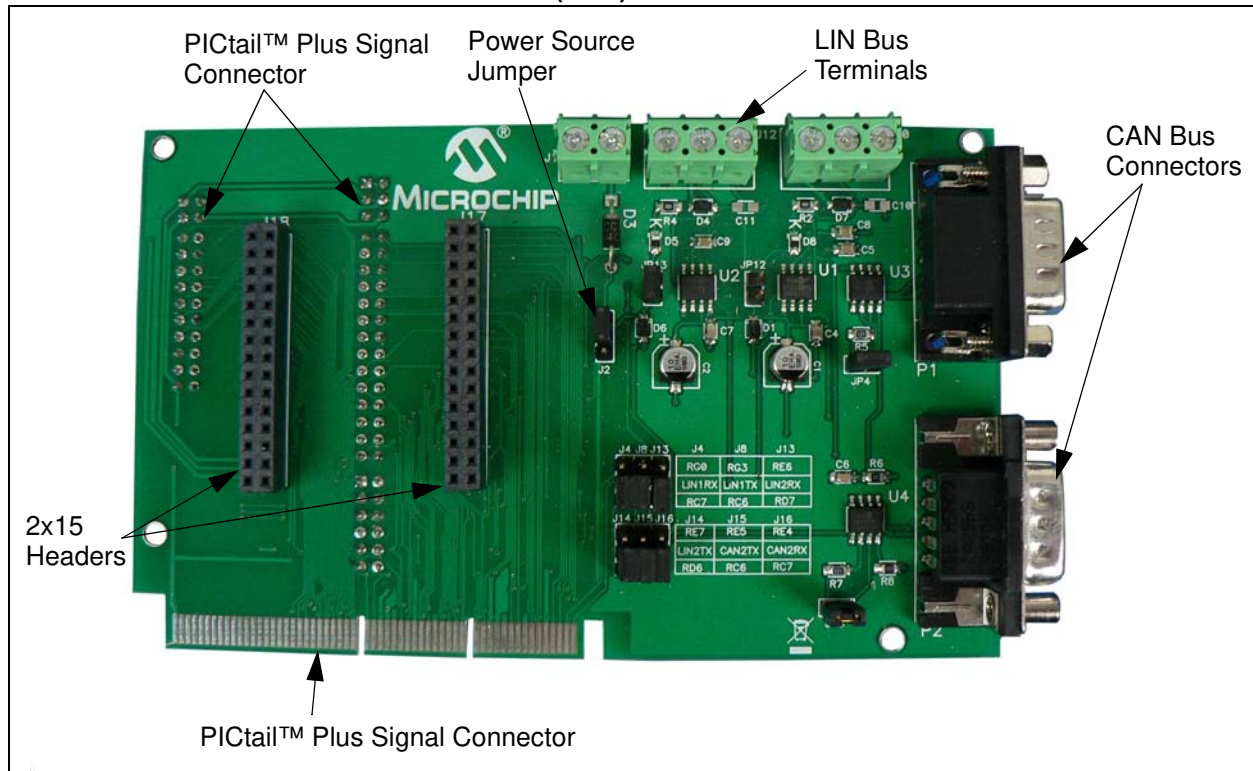

The daughter board obtains 9V DC input power from either the Explorer 16 Development Board through the 120-pin signal connector (J7) or the PIC18 Development Board through the 4-pin connector (J6) that is part of the PICtail™ daughter board connector on the underside of the board. The power supply to the LIN bus transceivers is switchable between the 9V available from the development board or an external +12V supply. This external power supply must be connected to J1. Jumper J2 must be set to use the required power supply.

# CAN/LIN/J2602 PICtail™ (Plus) Daughter Board User's Guide

## 2.2 HARDWARE COMPONENTS

Figure 2-2 identifies the key hardware components on the CAN/LIN/J2602 PICtail (Plus) Daughter Board.

**FIGURE 2-2: CAN/LIN/J2602 PICtail™ (Plus) DAUGHTER BOARD**

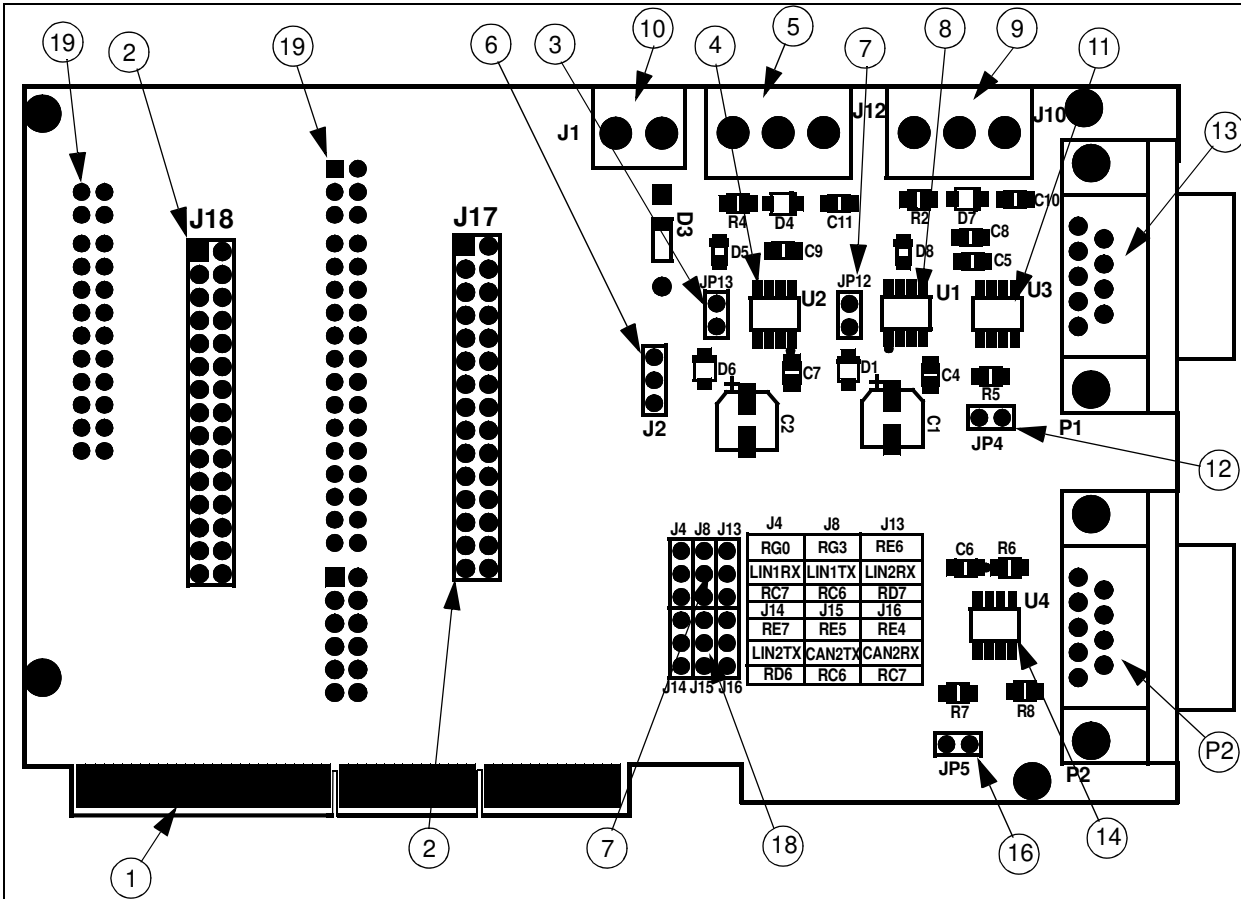

No.	Description	No.	Description
1	Explorer 16 Board PICtail™ Plus Connector (J7)	11	CAN1 Transceiver (U3)
2	Auxiliary Headers (J17, J18)	12	CAN1 Bus Termination Jumper (JP4)
3	LIN2 Master/Slave Jumper (JP13)	13	CAN1 Bus Connector (P2)
4	LIN2 Transceiver (U2)	14	CAN2 Transceiver (U4)
5	LIN2 Bus Connector (J12)	15	CAN2 Bus Connector (P2)
6	LIN Power Select Jumper (J2)	16	CAN2 Bus Termination Jumper (JP5)
7	LIN1 Master/Slave Jumper (JP12)	17	Alternate LIN 2 Module Pinout Jumpers (J4, J8, J13, J14)
8	LIN1 Transceiver (U1)	18	Alternate CAN 1 Module Alternate Pinout Jumpers (J15, J16)
9	LIN1 Bus Connector (J10)	19	PIC18 Explorer Board PICtail™ Connector (J3, J5, J6, J9, J11)
10	LIN External +12V DC Terminal Block (J1)		

## 2.2.1 Explorer 16 Board PICtail™ Connector (J7)

Explorer 16 Board PICtail connector J7 (see Reference 1), a 120-pin signal connector that carries signals from the I/O pins of the dsPIC33F or PIC24 device on the Explorer 16 Board to the CAN/LIN/J2602 PICtail (Plus) Daughter Board. This connector handles the following signals:

- 9V, 5V and 3.3V DC input to the CAN/LIN/J2602 PICtail (Plus) Daughter Board
- Signals from the ECAN modules on the dsPIC33F or PIC24 device to the CAN transceivers on the CAN/LIN/J2602 PICtail (Plus) Daughter Board
- Signals from the UART modules on the dsPIC33F or PIC24 device to the LIN transceivers on the CAN/LIN/J2602 PICtail (Plus) Daughter Board
- LIN Bus Fault Communication

## 2.2.2 Auxiliary Headers (J17, J18)

Auxiliary Headers J17 and J18 (see Reference 2) make a various set of signals available from the development board. These headers can be used for monitoring, testing and development purposes. Refer to **Section 2.3 “Auxiliary Header Pinouts”** as well as the board schematic for more details on these headers.

## 2.2.3 LIN Bus Master/Slave Select Jumpers (JP12, JP13)

The LIN1 and LIN2 Bus Master/Slave Select Jumpers (see Reference 3 or Reference 7) are used to indicate the presence of a master device on the LIN bus.

Placing jumper JP13 or JP12 pulls the LIN bus high via a 1K pull-up resistor. This can be detected by nodes on the LIN bus as an indication that a Master node is present. There can be only one Master node on a LIN bus.

## 2.2.4 LIN Transceivers (U1, U2)

A set of MCP2021 LIN transceivers (see Reference 8 and Reference 4) provide the interface between the UART modules on the dsPIC33F, PIC24 or PIC18 device and the LIN bus. The transceiver converts the signals from the UART modules on the control device to a 5V regulated signal for the LIN bus. The power supply to the LIN transceivers is selectable between +12V or +9V with jumper J2 (see Reference 6). While the +9V is available from the development board, the +12V supply must be connected externally to J1 (see Reference 10). For PIC18 devices, the LIN 1 and LIN 2 modules can be used on two sets of pins chosen by the J4, J8, J13 and J14 jumpers. Choose the correct pinout corresponding to which PIC18 device is used.

## 2.2.5 LIN Bus Connectors (J10, J12)

The LIN1 and LIN2 bus connectors are 3-pin terminal blocks that connect the CAN/LIN/J2602 PICtail (Plus) Daughter Board to a LIN bus. LIN1 connector J10 (see Reference 9) connects UART1 module on the dsPIC33F, PIC24 or PIC18 control device to the LIN bus via the LIN1 transceiver. LIN2 connector J12 (see Reference 5) connects UART 2 module on the dsPIC33F, PIC24 or PIC18 control device to the LIN bus via the LIN2 transceiver.

## 2.2.6 LIN Transceiver Power Supply Select Jumper (J2)

This 3-pin jumper (see Reference 6) selects the power supply to LIN transceivers U1 and U2. Either +9V DC is supplied from the development board or +12V DC is supplied from an external power supply connected to J1 (see Reference 10).

## 2.2.7 External +12V DC LIN Power Supply Terminal Block (J9)

External +12V DC power for the LIN transceivers must be connected to J1 (see Reference 10).

## 2.2.8 CAN Transceivers (U3, U4)

A pair of MCP2551 CAN transceivers (see Reference 11 and Reference 14) provide the interface between the ECAN modules on the dsPIC33F, PIC24 or PIC18 control device and the CAN bus. The transceiver converts the signals from the ECAN modules on the dsPIC33F, PIC24 or PIC18 device to a pair of differential CAN bus signals.

## 2.2.9 CAN Bus Termination Jumpers (JP4, JP5)

Termination Jumpers (JP4, JP5) are provided to terminate the CAN bus. Jumper JP4 (see Reference 12) places a 120 ohm termination resistor across the CAN bus connected to CAN1. Jumper JP5 (see Reference 16) places a 120 ohm termination resistor across the CAN bus connected to CAN2.

## 2.2.10 CAN Bus Connectors (P1, P2)

Nine-pin D-type connectors connect the CAN/LIN/J2602 PICtail (Plus) Daughter Board to a CAN bus. CAN1 connector P1 (see Reference 13) connects ECAN 1 module on the dsPIC33F, PIC24 or PIC18 control device to the CAN bus via the CAN transceiver. CAN2 connector P2 (see Reference 15) connects ECAN 2 module on the dsPIC33F or PIC24 device and the ECAN1 module's alternate pinout on the PIC18 device to the CAN bus via the CAN transceiver.

For PIC18 devices, the alternate pinout of the ECAN1 module can be used on two sets of pins chosen by the J15 and J16 jumpers. Choose the correct pinout corresponding to the PIC18 device used. The CAN bus provides high and low differential signals.

## 2.2.11 Alternate LIN1 and LIN2 Module Pinout Jumpers (J4, J8, J13, J14)

For PIC18 devices, depending on which device is used and how many pins it has, the LIN1 and LIN2 module will be available on two different sets of pins. The J4, J8, J13 and J14 jumpers are used to select between these two options (see Reference 17).

## 2.2.12 Alternate CAN1 Module Alternate Pinout Jumpers (J15, J16)

For PIC18 devices, depending on which device is used and how many pins it has, the CAN 1 module's alternate pinout chosen by its internal multiplex will be available on two different sets of pins. The J15 and J16 jumpers are used to select between these two options (see Reference 18).

## 2.2.13 PIC18 Explorer Board PICtail™ Connector (J3, J5, J6, J9, J11)

PIC18 Explorer Board PICtail connector (see Reference 19) is made up of five connectors that carry signals from the I/O pins of the PIC18 device on the PIC18 Explorer Board to the CAN/LIN/J2602 PICtail (Plus) Daughter Board. This connector handles the following signals:

- 9V, 5V and 3.3V DC input to the CAN/LIN/J2602 PICtail (Plus) Daughter Board
- Signals from the ECAN module on the PIC18 device to the CAN transceivers on the CAN/LIN/J2602 PICtail (Plus) Daughter Board
- Signals from the UART modules on the PIC18 device to the LIN transceivers on the CAN/LIN/J2602 PICtail (Plus) Daughter Board
- LIN Bus Fault Communication

## 2.3 AUXILIARY HEADER PINOUTS

The two auxiliary headers, J17 and J18, allow for monitoring and debugging other pins from the microcontroller as well as the CAN and LIN pins. Depending on which development board is being used, the auxiliary headers have different pinouts. Table 2-1 maps out microcontroller pins to header pins for both development boards, the PIC18 Explorer Board and the Explorer 16 Board. Refer to Figure A-4 for the schematic of the headers.

**Table 2-1: PINOUT MAP FOR MICROCONTROLLERS TO DEBUG HEADERS**

Header	Pin # on Header	Name of Pin on Header	PIC18 Explorer Pin	Explorer 16 Pin
J17	1	DEBUG1	RE2	RB2
J17	2	DEBUG2	RA5	RF6
J17	3	DEBUG3	RE3	RF7
J17	4	DEBUG4	RA4	RG2
J17	5	DEBUG5	RA7	RF8
J17	6	DEBUG6	RA3	RG3
J17	7	DEBUG7	RA6	RB0
J17	8	DEBUG8	RC5	RB1
J17	9	DEBUG9	RC4	RB3
J17	10	DEBUG10	RC3	RB4
J17	11	DEBUG11	RB7	RE9
J17	12	DEBUG12	RA0	RD14
J17	13	DEBUG13	RB6	RG0
J17	14	DEBUG14	RA1	RG1
J17	15	DEBUG15	RA2	RG9
J17	16	DEBUG16	RC0	RG6
J17	17	DEBUG17	RC1	RG7
J17	18	DEBUG18	RB0	RA2
J17	19	DEBUG19	RD1	RG8
J17	20	DEBUG20	RD0	RA3
J17	21	DEBUG21	RD3	RB8
J17	22	DEBUG22	RD2	RB9
J17	23	DEBUG23	RD5	RA9
J17	24	DEBUG24	RD4	RA10
J17	25	DEBUG25	RE1	RA15
J17	26	DEBUG26	RE0	RF12
J17	27	DEBUG27	RG1	RG15
J17	28	DEBUG28	RG2	RG13
J17	29	DEBUG29	RG5	RG12
J17	30	DEBUG30	RG4	RG14
J18	1	DEBUG31	RF1	RA0
J18	2	DEBUG32	RF0	RA1
J18	3	DEBUG33	RF3	RA4
J18	4	DEBUG34	RF2	RA5
J18	5	DEBUG35	RF5	RA6
J18	6	DEBUG36	RF4	RA7
J18	7	DEBUG37	RF7	RB6

# CAN/LIN/J2602 PICtail™ (Plus) Daughter Board User's Guide

Table 2-1: PINOUT MAP FOR MICROCONTROLLERS TO DEBUG HEADERS (Continued)

Header	Pin # on Header	Name of Pin on Header	PIC18 Explorer Pin	Explorer 16 Pin
J18	8	DEBUG38	RF6	RB7
J18	9	DEBUG39	NC	RB5
J18	10	DEBUG40	NC	RB10
J18	11	DEBUG41	NC	RB11
J18	12	DEBUG42	NC	RB12
J18	13	DEBUG43	NC	RB13
J18	14	DEBUG44	NC	RB14
J18	15	CAN1TX	RB2	RF1
J18	16	CAN1RX	RB3	RF2
J18	17	CAN2TX	RC6 or RE5 (see J15)	RG1
J18	18	CAN2RX	RC7 or RE4 (see J16)	RG0
J18	19	LIN1TX	RC6 or RG3 (see J8)	RF3
J18	20	LIN1RX	RC7 or RG0 (see J4)	RF2
J18	21	LIN1CS	RB1	RE8
J18	22	LIN1TXE	RC2	RD15
J18	23	LIN2TX	RD6 or RD7 (see J14)	RF5
J18	24	LIN2RX	RD7 or RE6 (see J13)	RF4
J18	25	LIN2CS	RB4	RA14
J18	26	LIN2TXE	Must be connected to either 5V or unused PIC18 pin on the J18 header	RF13



# CAN/LIN/J2602 PICtail™ (Plus) DAUGHTER BOARD USER'S GUIDE

---

## Chapter 3. CAN/LIN/J2602 PICtail (Plus) Daughter Board Tutorial Program

---

This chapter provides a brief description of the code that can be used with the CAN/LIN/J2602 PICtail (Plus) Daughter Board. When connected to the PIC18 Explorer Board, the code included with the board can be used. When the daughter board is connected to the Explorer 16 Board, some examples available on Microchip's web site ([www.microchip.com](http://www.microchip.com)) can be used. Topics covered include:

- PIC18 Tutorial Overview
- dsPIC33F and PIC24H Tutorial Overview

### 3.1 PIC18 TUTORIAL OVERVIEW

The PIC18 tutorial in this chapter demonstrates the CAN module features of the PIC18FXXK80 family in mode 1. When either the PIC18F46K80 PIM or PIC18F66K80 PIM is connected to the PIC18 Explorer Board, and is interfaced with the CAN/LIN/J2602 PICtail (Plus) Daughter Board, the tutorial demonstrates how to transmit and receive with the CAN module.

The PIC18 tutorial project, `ECAN_Daughterboard.mcp`, is written in C for MPLAB C18. Make sure that the correct PIC18FXXK80 device is chosen for the project. This tutorial program transmits data over the CAN bus when the RB0 push button is pressed, and has three filters with three buffers to receive data sent over the CAN bus. The project contains three files, `main.c`, `CAN.c`, and `CAN.h`. The `CAN.c` and `CAN.h` files contain the functions used for CAN communication. These files can be easily ported to other projects if needed. The `main.c` file contains the code that handles the CAN communication for this specific tutorial.

Specifically for this example, while running in mode 1, when a CAN message is received that fits one of the three filters, 0x111, 0x444, and 0x0A0, the LEDs on PORTD increment by one. When the push button on RB0 is pressed, a CAN message is transmitted. To show that the device is working properly, the LED on RD7 is toggled continuously at a constant rate.

To effectively demonstrate this tutorial, a device is needed to transmit and receive messages to and from the PIC18FXXK80. Any device capable of CAN communication can be used, but a CAN bus analyzer is the simplest to use. Microchip has a CAN bus analyzer available for purchase on the web called the CAN bus Analyzer Tool (APGDT002). This analyzer tool can query the CAN bus for all messages transmitted and received. It can be connected to the DB9 connectors on the CAN/LIN/J2602 PICtail (Plus) Daughter Board.

## 3.2 dsPIC33F and PIC24H Tutorial Overview

### 3.2.1 ECAN Software

Several code examples are available to demonstrate the usage and functionality of the ECAN module on the dsPIC33F and PIC24H device families. These code examples include:

- dsPIC33F code examples:
  - CE127: Crosswire Communication between ECAN1 and ECAN2 modules
  - CE128: ECAN FIFO Receive Example
  - CE129: Processing of Remote Transmission Requests using ECAN
- PIC24H code examples:
  - CE227: Crosswire Communication between ECAN1 and ECAN2 modules
  - CE228: ECAN FIFO Receive Example
  - CE229: Processing of Remote Transmission Requests using ECAN

All dsPIC33F and PIC24H code examples are available as freely-downloadable source code on the web site: [www.microchip.com/codeexamples](http://www.microchip.com/codeexamples).

In addition, the dsPIC33F/PIC24H Peripheral Library, included with the MPLAB C30 compiler, contains several driver functions for the ECAN module.

### 3.2.2 LIN Software

LIN Master and Slave driver functions and application examples supporting the dsPIC33F, PIC24H and PIC24F device families are under development.

This software will be available for free download from the Microchip web site ([www.microchip.com](http://www.microchip.com)), along with an Application Note describing the usage and functionality of the LIN drivers.

**Appendix A. Drawings and Schematics**

This appendix provides drawings and schematic diagrams of the CAN/LIN/J2602 PICtail (Plus) Daughter Board for both Revision 1 and Revision 2.

**A.1 CAN/LIN/J2602 PICTAIL™ (Plus) DAUGHTER BOARD LAYOUT**

Figure A-1 is a drawing of the CAN/LIN/J2602 PICtail (Plus) Daughter Board (AC164130-2) layout. Figure A-2 is a drawing of the CAN/LIN/J2602 PICtail (Plus) Daughter Board (AC164130) layout.

**FIGURE A-1: CAN/LIN/J2602 PICTAIL™ (Plus) DAUGHTER BOARD (AC164130-2) LAYOUT (REVISION 2)**

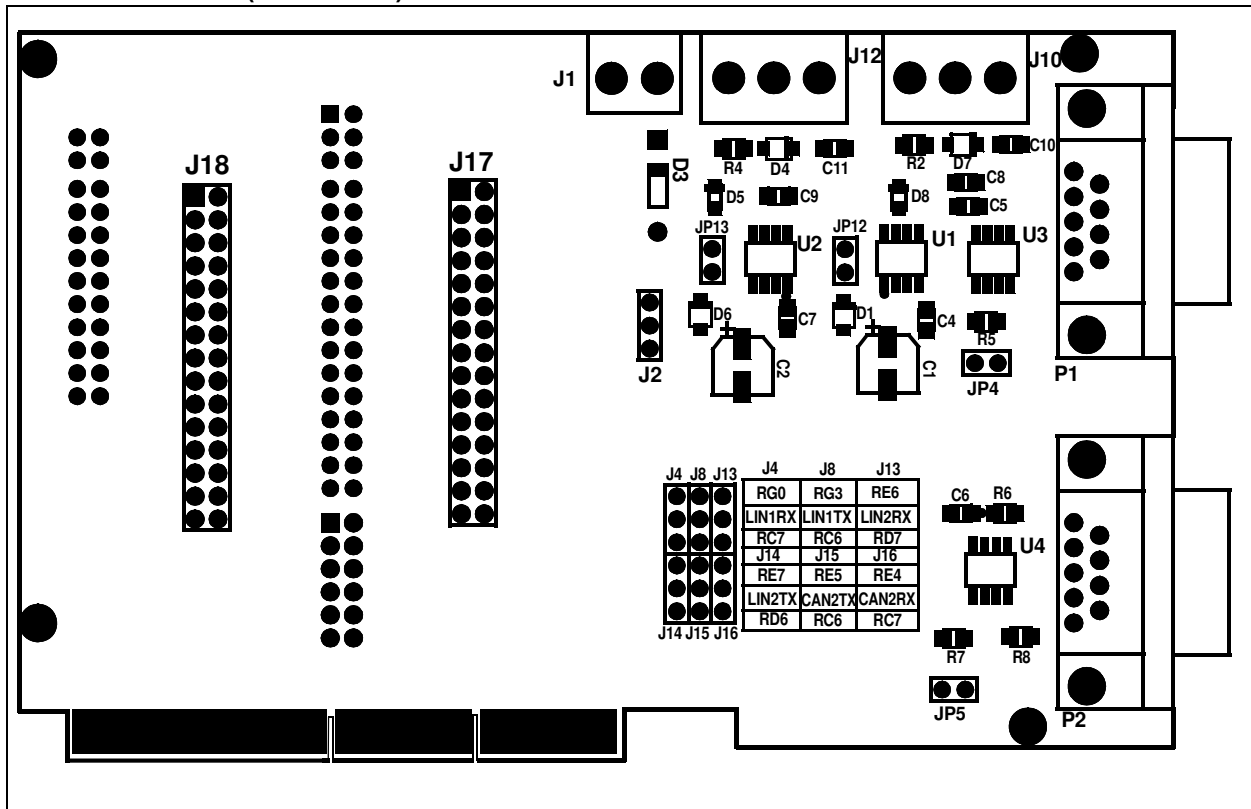

# CAN/LIN/J2602 PICtail™ (Plus) Daughter Board User's Guide

**FIGURE A-2: CAN/LIN/J2602 PICtail™ (Plus) DAUGHTER BOARD (AC164130) LAYOUT (REVISION 2)**

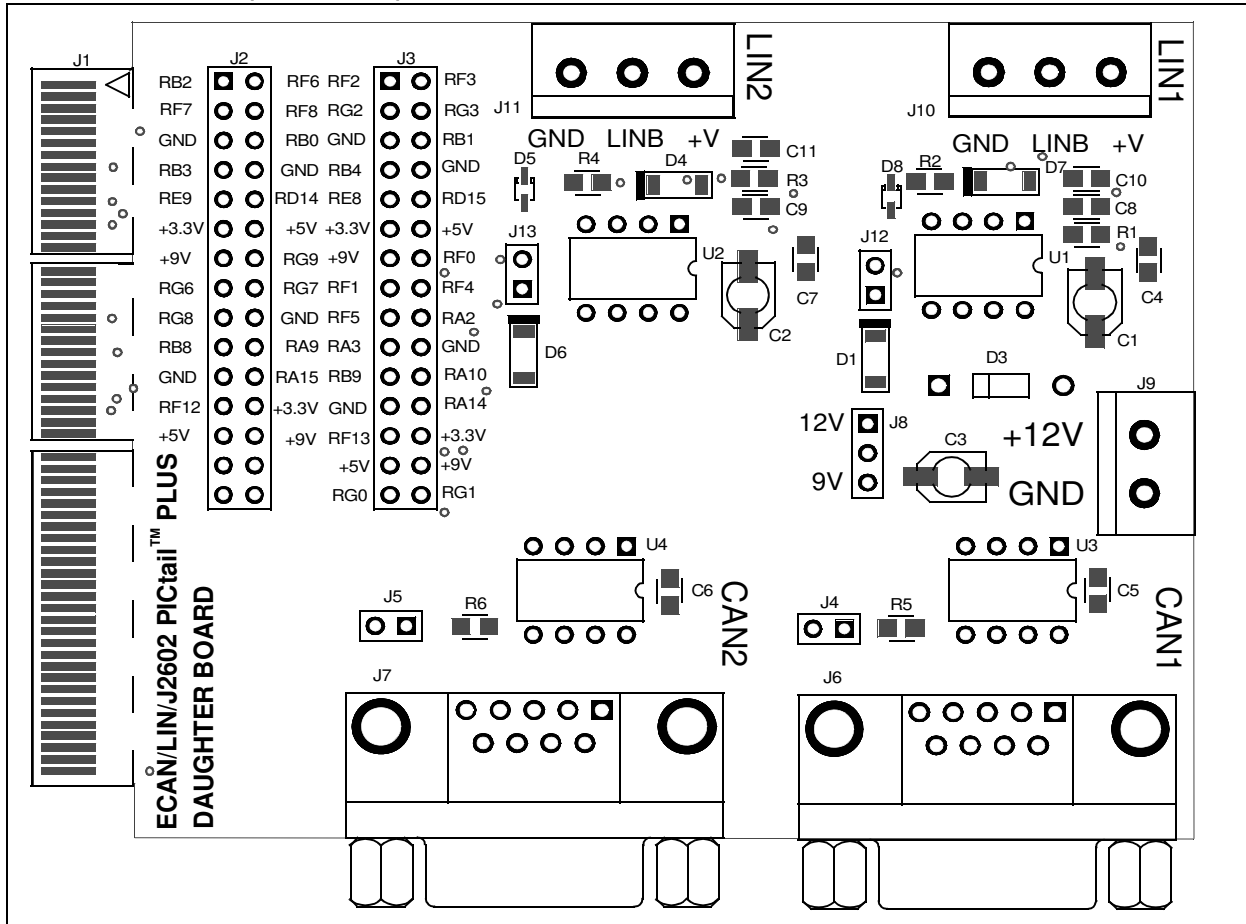

## A.2 SCHEMATIC DIAGRAMS

This appendix shows the schematic diagrams for both Revision 1 and Revision 2. The following schematic diagrams are included in this appendix for AC164130-2 revision of the CAN/LIN/J2602 PICtail (Plus) Daughter Board:

- Figure A-3: LIN and CAN Circuit Schematics
- Figure A-4: Connector and Header Pinout Schematics

The following schematic diagrams are included in this appendix for Revision 1 of the CAN/LIN/J2602 PICtail (Plus) Daughter Board:

- Figure A-5: LIN Circuit Schematics
- Figure A-6: CAN Circuit Schematics
- Figure A-7: Connector and Header Pinout Schematics
- Figure A-8: (AC164130) of the CAN/LIN/J2602 PICtail (Plus) Daughter Board.

FIGURE A-3: LIN AND CAN CIRCUIT SCHEMATICS

