



Chipsmall Limited consists of a professional team with an average of over 10 year of expertise in the distribution of electronic components. Based in Hongkong, we have already established firm and mutual-benefit business relationships with customers from,Europe,America and south Asia,supplying obsolete and hard-to-find components to meet their specific needs.

With the principle of "Quality Parts,Customers Priority,Honest Operation,and Considerate Service",our business mainly focus on the distribution of electronic components. Line cards we deal with include Microchip,ALPS,ROHM,Xilinx,Pulse,ON,Everlight and Freescale. Main products comprise IC,Modules,Potentiometer,IC Socket,Relay,Connector.Our parts cover such applications as commercial,industrial, and automotives areas.

We are looking forward to setting up business relationship with you and hope to provide you with the best service and solution. Let us make a better world for our industry!



Contact us

Tel: +86-755-8981 8866 Fax: +86-755-8427 6832

Email & Skype: info@chipsmall.com Web: www.chipsmall.com

Address: A1208, Overseas Decoration Building, #122 Zhenhua RD., Futian, Shenzhen, China



MRF24WN0MA PICtail™/PICtail Plus Daughter Board Information Sheet

Overview

The MRF24WN0MA PICtail/PICtail Plus Daughter Board is a development and demonstration board for evaluating Wi-Fi® connectivity using PIC® microcontrollers and the MRF24WN0MA module.

Features

- MRF24WN0MA Wi-Fi module with 802.11n connectivity
- Daughter board supports PICtail and PICtail Plus connectors.

Getting Started

To get started, an Explorer 16 or PIC32 Starter Kit with PIC32 I/O Expansion board can be used. Alternatively, PIC32 MEB2 board can be used. Please make sure to select the PIC32 with sufficient flash and RAM memory to be able to run the TCP/IP stack and your application. With the appropriate hardware available, download Microchip TCP/IP Stack and follow the Getting Started chapter of the TCP/IP Stack Help.

TCP/IP Stack and Firmware

The Microchip TCP/IP stack and other firmware examples can be downloaded with the MPLAB® Harmony framework at www.microchip.com/harmony. Support for the MRF24WN0MA PICtail/PICtail Plus Daughter Board is in the TCP/IP Stack version 1.06 and later. After installation, a link to the TCP/IP Stack Help is available in the Start Menu.

TABLE 1: SIGNAL INTERFACE

Function	I/O	PICtail™ Pin	PICtail Plus Pin	Description
SPI_CS/MODE	I	RC2/24	RB2/1	SPI Chip Select
SPI_CLK	I	RC3/12	RF6/3	SPI Clock
SPI_MISO	O	RC4/10	RF7/5	SPI Data Out from MRF24WN0MA
SPI_MOSI	I	RC5/8	RD0/7	SPI Data In to MRF24WN0MA
SPI_INT	O	RB0/27	RE8/18	Open Drain Interrupt Signal to Microcontroller
HIBERNATE	I	RB2/23	RF1/30	Hibernate Signal to MRF24WN0MA

Wireless Router Configuration

The Microchip TCP/IP stack examples are written to interface to a wireless router with the following configuration:

SSID: MicrochipDemoAP
Channel: 1, 6, or 11
Security: Disabled

This configuration can be changed by use of MPLAB Harmony Configurator (MHC).

Americas

Atlanta, GA - 678-957-9614
Austin, TX - 512-257-3370
Boston, MA - 774-760-0087
Chicago, IL - 630-285-0071
Cleveland, OH - 216-447-0464
Dallas, TX - 972-818-7423
Detroit, MI - 248-848-4000
Houston, TX - 281-894-5983
Indianapolis, IN - 317-773-8323
Los Angeles, CA - 949-462-9523
New York, NY - 631-435-6000
Phoenix - 480-792-7200
San Jose, CA - 408-735-9110
Canada - Toronto - 905-673-0699

Europe

Austria - Wels - 43-7242-2244-39
Denmark - Copenhagen - 45-4450-2828
France - Paris - 33-1-69-53-63-20
Germany - Dusseldorf - 49-2129-3766400
Germany - Karlsruhe - 49-721-625370
Germany - Munich - 49-89-627-144-0
Italy - Milan - 39-0331-742611
Italy - Venice - 39-049-7625286
Netherlands - Drunen - 31-416-690399
Poland - Warsaw - 48-22-3325737
Spain - Madrid - 34-91-708-08-90
Sweden - Stockholm - 46-8-5090-4654
UK - Wokingham - 44-118-921-5800

Asia/Pacific

Hong Kong - 852-2943-5100
Australia - Sydney - 61-2-9868-6733
China - Beijing - 86-10-8569-7000
China - Chengdu - 86-28-8665-5511
China - Chongqing - 86-23-8980-9588
China - Dongguan - 86-769-8702-9880
China - Hangzhou - 86-571-8792-8115
China - Hong Kong SAR - 852-2943-5100
China - Nanjing - 86-25-8473-2460
China - Qingdao - 86-532-8502-7355
China - Shanghai - 86-21-5407-5533
China - Shenyang - 86-24-2334-2829
China - Shenzhen - 86-755-8864-2200
China - Wuhan - 86-27-5980-5300
China - Xiamen - 86-592-2388138
China - Xian - 86-29-8833-7252
China - Zhuhai - 86-756-3210040
India - Bangalore - 91-80-3090-4444
India - New Delhi - 91-11-4160-8631
India - Pune - 91-20-3019-1500
Korea - Daegu - 82-53-744-4301
Korea - Seoul - 82-2-554-7200
Malaysia - Kuala Lumpur - 60-3-6201-9857
Malaysia - Penang - 60-4-227-8870
Philippines - Manila - 63-2-634-9065
Singapore - 65-6334-8870
Taiwan - Hsin Chu - 886-3-5778-366
Taiwan - Kaohsiung - 886-7-213-7828
Taiwan - Taipei - 886-2-2508-8600
Thailand - Bangkok - 66-2-694-1351

07/14/15



Microchip Technology Inc. • 2355 West Chandler Blvd. • Chandler, AZ 85224-6199
www.microchip.com

The Microchip name and logo, the Microchip logo, PIC and MPLAB are registered trademarks of Microchip Technology Incorporated in the U.S.A. and other countries. All other trademarks mentioned herein are property of their respective companies.

© 2015, Microchip Technology Incorporated. All Rights Reserved.

DS50002402A

MRF24WN0MA PICtail™/PICtail Plus Daughter Board Schematic

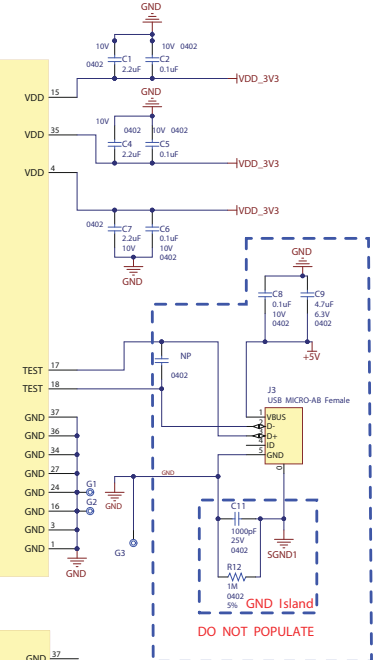
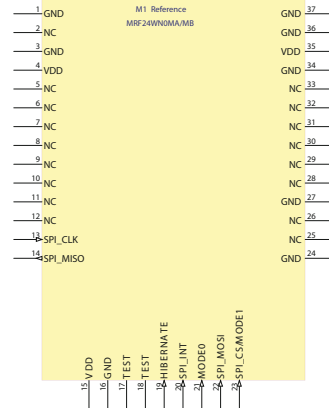
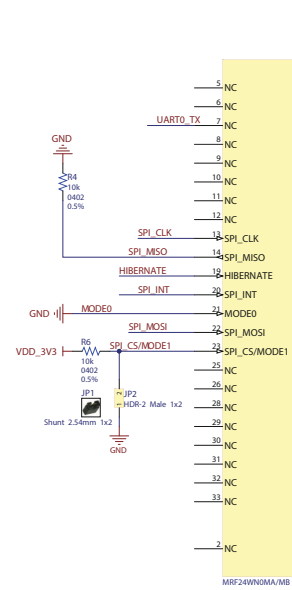
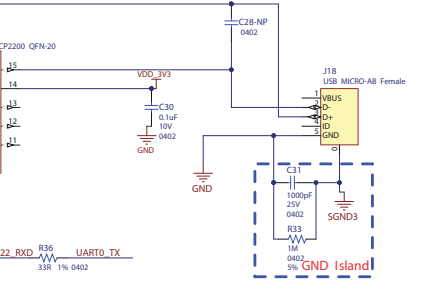
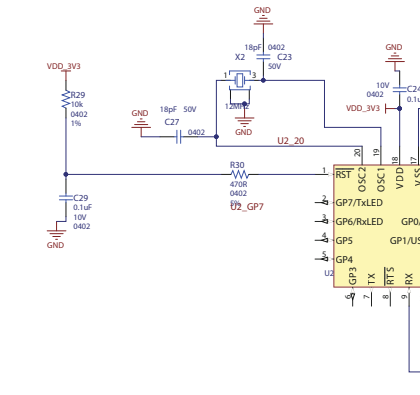
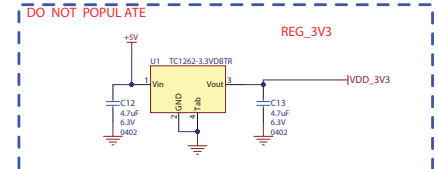
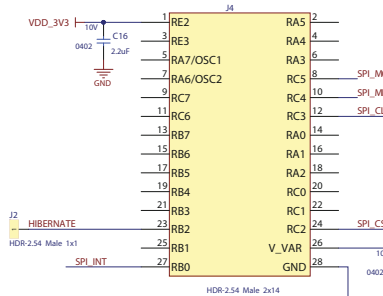
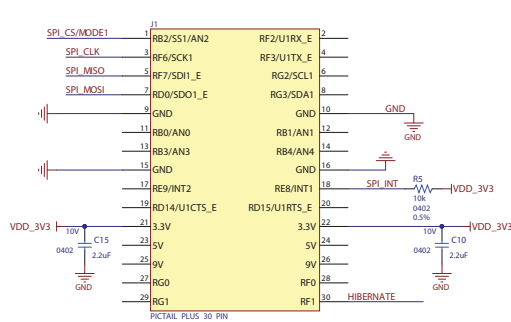

JUMPER TABLE	
JP2	Status
Off (open)	Normal Mode
On (short)	Test Mode