



Chipsmall Limited consists of a professional team with an average of over 10 year of expertise in the distribution of electronic components. Based in Hongkong, we have already established firm and mutual-benefit business relationships with customers from,Europe,America and south Asia,supplying obsolete and hard-to-find components to meet their specific needs.

With the principle of “Quality Parts,Customers Priority,Honest Operation,and Considerate Service”,our business mainly focus on the distribution of electronic components. Line cards we deal with include Microchip,ALPS,ROHM,Xilinx,Pulse,ON,Everlight and Freescale. Main products comprise IC,Modules,Potentiometer,IC Socket,Relay,Connector.Our parts cover such applications as commercial,industrial, and automotives areas.

We are looking forward to setting up business relationship with you and hope to provide you with the best service and solution. Let us make a better world for our industry!



Contact us

Tel: +86-755-8981 8866 Fax: +86-755-8427 6832

Email & Skype: info@chipsmall.com Web: www.chipsmall.com

Address: A1208, Overseas Decoration Building, #122 Zhenhua RD., Futian, Shenzhen, China



LAN9303 PHY Daughter Board Information Sheet

The LAN9303 PHY Daughter Board (AC320004-4) enables Ethernet communication with a variety of Microchip starter kits. For more information, please visit: <http://www.microchip.com>. From the Design Support menu, click **Development Tools**. Then, from the Starter Kits menu, click **MPLAB Starter Kit**, and then select the desired starter kit.

Schematics

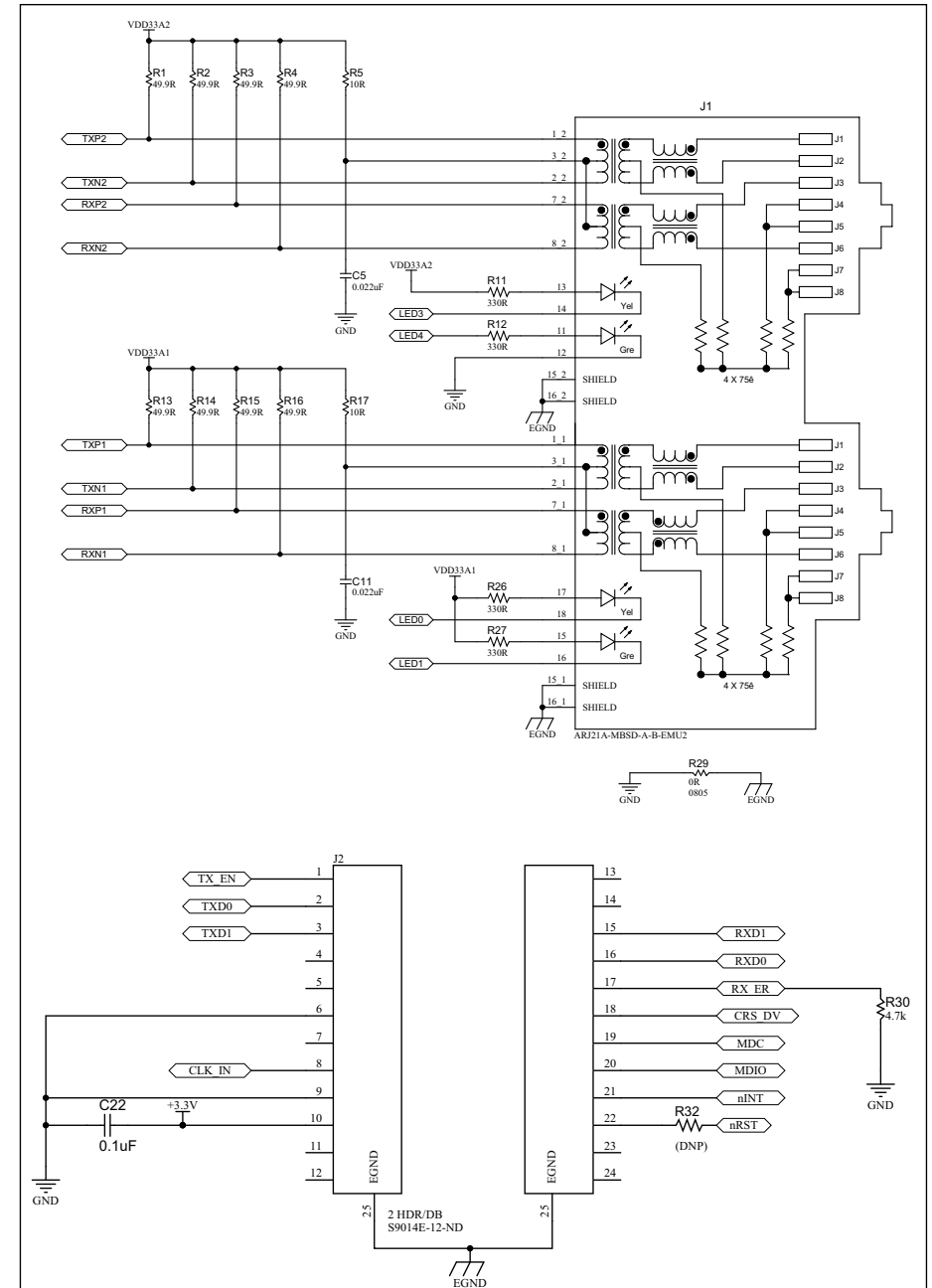

Americas

Atlanta - 678-957-9614
 Austin - 512-257-3370
 Boston - 774-760-0087
 Chicago - 630-285-0071
 Cleveland - 216-447-0464
 Dallas - 972-818-7423
 Detroit - 248-848-4000
 Houston - 281-894-5983
 Indianapolis - 317-773-8323
 Los Angeles - 949-462-9523
 New York - 631-435-6000
 Phoenix - 480-792-7200
 Santa Clara - 408-961-6444
 Toronto - 905-673-0699

Europe

Austria - Wels - 43-7242-2244-39
 Denmark - Copenhagen - 45-4450-2828
 France - Paris - 33-1-69-53-63-20
 Germany - Munich - 49-89-627-144-0
 Italy - Milan - 39-0331-742611
 Netherlands - Drunen - 31-416-690399
 Spain - Madrid - 34-91-708-08-90
 UK - Wokingham - 44-118-921-5869

Asia/Pacific

Australia - Sydney - 61-2-9868-6733
 China - Beijing - 86-10-8569-2100

Asia/Pacific (Continued)

China - Chengdu - 86-28-8665-5511
 China - Chongqing - 86-23-8980-9588
 China - Hangzhou - 86-571-8792-8115
 China - Hong Kong SAR - 852-2943-5100
 China - Nanjing - 86-25-8473-2460
 China - Qingdao - 86-532-8502-7355
 China - Shanghai - 86-21-5407-5533
 China - Shenyang - 86-24-2334-2829
 China - Shenzhen - 86-755-8864-2200
 China - Wuhan - 86-27-5980-5300
 China - Xiamen - 86-592-2388138
 China - Xian - 86-29-8833-7252
 China - Zhuhai - 86-756-3210040
 India - Bangalore - 91-80-3090-4444
 India - New Delhi - 91-11-4160-8631
 India - Pune - 91-20-3019-1500
 Japan - Osaka - 81-6-6152-7160
 Japan - Tokyo - 81-3-6880-3770
 Korea - Daegu - 82-53-744-4301
 Korea - Seoul - 82-2-554-7200
 Malaysia - Kuala Lumpur - 60-3-6201-9857
 Malaysia - Penang - 60-4-227-8870
 Philippines - Manila - 63-2-634-9065
 Singapore - 65-6334-8870
 Taiwan - Hsin Chu - 886-3-5778-366
 Taiwan - Kaohsiung - 886-7-213-7840
 Taiwan - Taipei - 886-2-2508-8600
 Thailand - Bangkok - 66-2-694-1351

03/25/14



MICROCHIP

Microchip Technology Inc. • 2355 West Chandler Blvd. • Chandler, AZ 85224-6199

www.microchip.com

The Microchip name and logo, the Microchip logo, and MPLAB are registered trademarks of Microchip Technology Incorporated in the U.S.A. and other countries. All other trademarks mentioned herein are property of their respective companies. © 2014, Microchip Technology Incorporated, Printed in the U.S.A. All Rights Reserved. 03/14

DS50002276A



LAN9303 PHY Daughter Board Information Sheet

Schematics (Continued)

