



Chipsmall Limited consists of a professional team with an average of over 10 year of expertise in the distribution of electronic components. Based in Hongkong, we have already established firm and mutual-benefit business relationships with customers from,Europe,America and south Asia,supplying obsolete and hard-to-find components to meet their specific needs.

With the principle of “Quality Parts,Customers Priority,Honest Operation,and Considerate Service”,our business mainly focus on the distribution of electronic components. Line cards we deal with include Microchip,ALPS,ROHM,Xilinx,Pulse,ON,Everlight and Freescale. Main products comprise IC,Modules,Potentiometer,IC Socket,Relay,Connector.Our parts cover such applications as commercial,industrial, and automotives areas.

We are looking forward to setting up business relationship with you and hope to provide you with the best service and solution. Let us make a better world for our industry!



Contact us

Tel: +86-755-8981 8866 Fax: +86-755-8427 6832

Email & Skype: info@chipsmall.com Web: www.chipsmall.com

Address: A1208, Overseas Decoration Building, #122 Zhenhua RD., Futian, Shenzhen, China



KSZ8041 PHY Daughter Board Information Sheet

The KSZ8041 PHY Daughter Board ([AC320004-5](#)) enables Ethernet communication with a variety of Microchip starter kits. This information sheet provides an overview and a detailed schematic of the KSZ8041 PHY Daughter Board.

This daughter board is designed specifically to be used with the PIC32 Ethernet Starter Kit II ([DM320004-2](#)) or the PIC32MZ Embedded Connectivity with Floating Point Unit (EF) Starter Kit ([DM320007](#)); however, it can also be used with other Microchip development hardware.

Please visit <http://www.microchip.com> for additional information on the daughter board.

Features

The KSZ8041 PHY Daughter Board features a 22-pin header for connecting the board into compatible PIC32 starter kits. The board has a KSZ8041 Ethernet Physical Layer Chip, configured to use RMII. The daughter board is suitable for use with the PIC32 Ethernet Starter Kit II and PIC32MZ EF Starter Kit.

Features of the KSZ8041 PHY Daughter Board includes:

- RMII interface with MDC/MDIO management interface for register configuration
- Single-Chip 10BASE-T/100BASE-TX Physical Layer Solution
- Fully compliant to IEEE 802.3u standard
- Low-power CMOS design, power consumption of <180 mW
- HP Auto MDI/MDI-X for reliable detection and correction for straight-through, and crossover cables with disable and enable options
- Robust operation over standard cables

Additional Information

For additional information on drivers and examples, please visit:

- <http://www.microchip.com/wwwproducts/en/KSZ8041>
- <http://www.microchip.com/mplab/mplab-harmony>

Americas

Atlanta - 678-957-9614
Austin - 512-257-3370
Boston - 774-760-0087
Chicago - 630-285-0071
Cleveland - 216-447-0464
Dallas - 972-818-7423
Detroit - 248-848-4000
Houston - 281-894-5983
Indianapolis - 317-773-8323
Los Angeles - 949-462-9523
New York - 631-435-6000
Phoenix - 480-792-7200
Santa Clara - 408-961-6444
Toronto - 905-673-0699

Europe

Austria - Wels - 43-7242-2244-39
Denmark - Copenhagen - 45-4450-2828
France - Paris - 33-1-69-53-63-20
Germany - Munich - 49-89-627-144-0
Italy - Milan - 39-0331-742611
Netherlands - Drunen - 31-416-690399
Spain - Madrid - 34-91-708-08-90
UK - Wokingham - 44-118-921-5869

Asia/Pacific

Australia - Sydney - 61-2-9868-6733
China - Beijing - 86-10-8569-2100

Asia/Pacific (Continued)

China - Chengdu - 86-28-8665-5511
China - Chongqing - 86-23-8980-9588
China - Hangzhou - 86-571-8792-8115
China - Hong Kong SAR - 852-2943-5100
China - Nanjing - 86-25-8473-2460
China - Qingdao - 86-532-8502-7355
China - Shanghai - 86-21-5407-5533
China - Shenyang - 86-24-2334-2829
China - Shenzhen - 86-755-8864-2200
China - Wuhan - 86-27-5980-5300
China - Xiamen - 86-592-2388138
China - Xian - 86-29-8833-7252
China - Zhuhai - 86-756-3210040
India - Bangalore - 91-80-3090-4444
India - New Delhi - 91-11-4160-8631
India - Pune - 91-20-3019-1500
Japan - Osaka - 81-6-6152-7160
Japan - Tokyo - 81-3-6880-3770
Korea - Daegu - 82-53-744-4301
Korea - Seoul - 82-2-554-7200
Malaysia - Kuala Lumpur - 60-3-6201-9857
Malaysia - Penang - 60-4-227-8870
Philippines - Manila - 63-2-634-9065
Singapore - 65-6334-8870
Taiwan - Hsin Chu - 886-3-5778-366
Taiwan - Kaohsiung - 886-7-213-7840
Taiwan - Taipei - 886-2-2508-8600
Thailand - Bangkok - 66-2-694-1351

01/11/17



Microchip Technology Inc. • 2355 West Chandler Blvd. • Chandler, AZ 85224-6199

www.microchip.com

The Microchip name and logo, the Microchip logo, and MPLAB are registered trademarks of Microchip Technology Incorporated in the U.S.A. and other countries. All other trademarks mentioned herein are property of their respective companies. © 2014, Microchip Technology Incorporated, Printed in the U.S.A. All Rights Reserved. 01/17

DS50002677A



KSZ8041 PHY Daughter Board Schematic

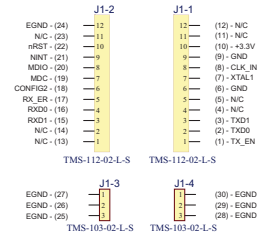
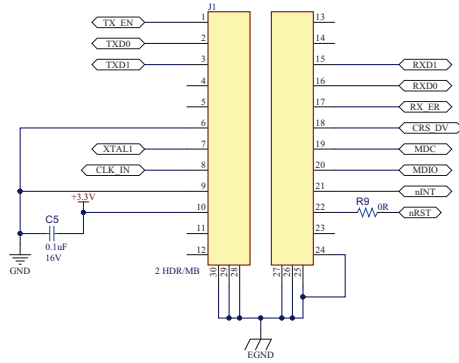
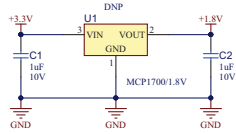

J1 PHY FOOTPRINT HEADER CONFIGURATION

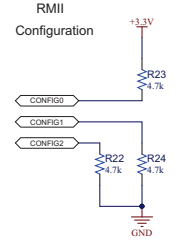
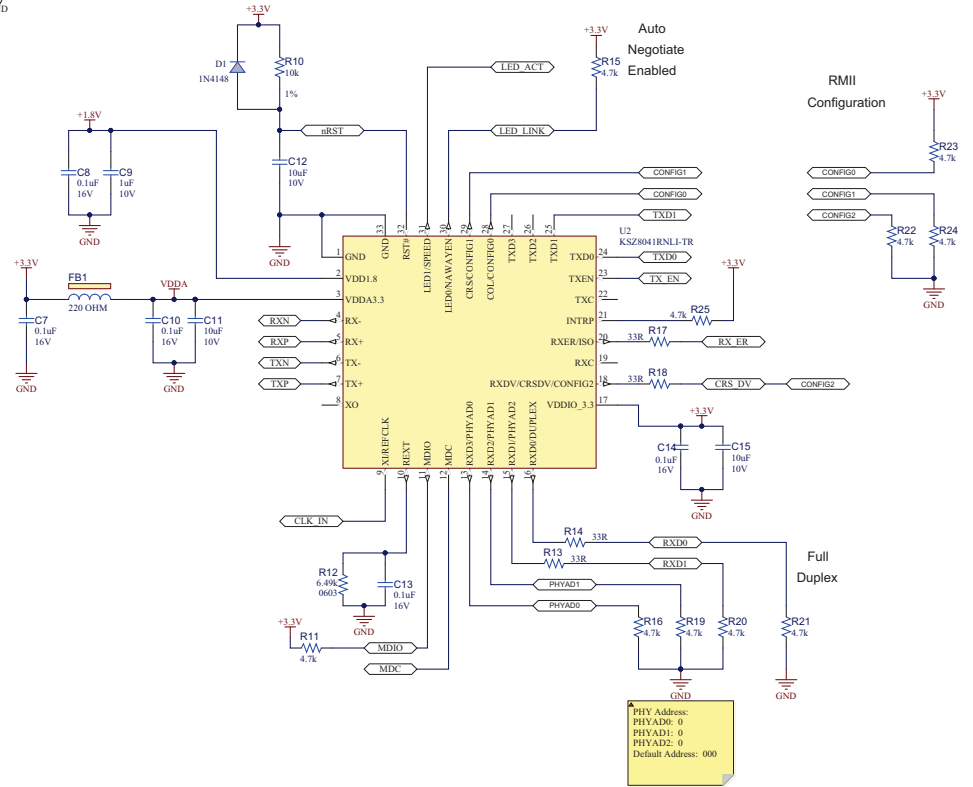
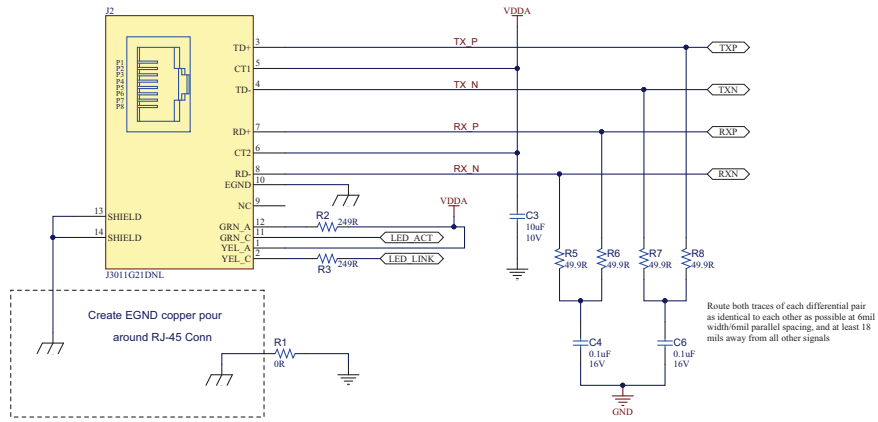

PHY Address:
PHYAD0: 0
PHYAD1: 0
PHYAD2: 0
Default Address: 000