



Chipsmall Limited consists of a professional team with an average of over 10 year of expertise in the distribution of electronic components. Based in Hongkong, we have already established firm and mutual-benefit business relationships with customers from,Europe,America and south Asia,supplying obsolete and hard-to-find components to meet their specific needs.

With the principle of “Quality Parts,Customers Priority,Honest Operation,and Considerate Service”,our business mainly focus on the distribution of electronic components. Line cards we deal with include Microchip,ALPS,ROHM,Xilinx,Pulse,ON,Everlight and Freescale. Main products comprise IC,Modules,Potentiometer,IC Socket,Relay,Connector.Our parts cover such applications as commercial,industrial, and automotives areas.

We are looking forward to setting up business relationship with you and hope to provide you with the best service and solution. Let us make a better world for our industry!



Contact us

Tel: +86-755-8981 8866 Fax: +86-755-8427 6832

Email & Skype: info@chipsmall.com Web: www.chipsmall.com

Address: A1208, Overseas Decoration Building, #122 Zhenhua RD., Futian, Shenzhen, China





AC7MDT10-D20/S20

DIP20/SO20 Connection Kit for ST7MDT10-EMU3

DATA BRIEF

The **DIP20/SO20 Connection Kit** (AC7MDT10-D20/S20) provides the hardware you need to connect your ST7MDT10-EMU3 emulator to your application when debugging applications for ST7 microcontrollers in DIP20 and SO20 packages.

Connection Kit Contents

- **DIP20 adapter** (DB482A) – Allows the connection of your ST7MDT10-EMU3 emulator to your application board in place of your ST7.
- **DIP20-DIP20 device adapter** (DB535) – Adapts the pin out of the DIP20 adapter to the DIP20 footprint of the ST7 on your application board.
- **DIP20-SO20 device adapter** (DB093) – Adapts the DIP20 adapter to SO20 footprint of the ST7 on your application board.

For more information...

- **ST7-EMU3 User Manual** – Information common to all EMU3 series emulators
- **ST7MDT10-EMU3 Probe User Guide** – Information specific to ST7MDT10-EMU3

Figure 1. DIP20 adapter

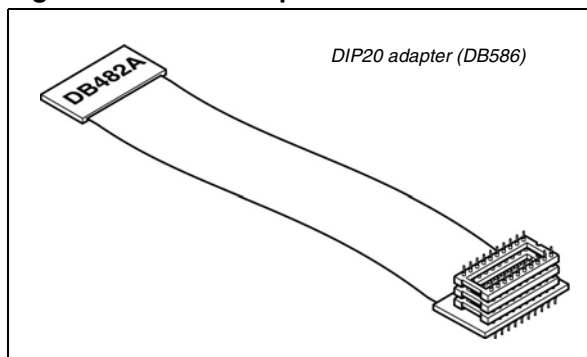

Figure 2. DIP20 adapter, DIP20 device adapter

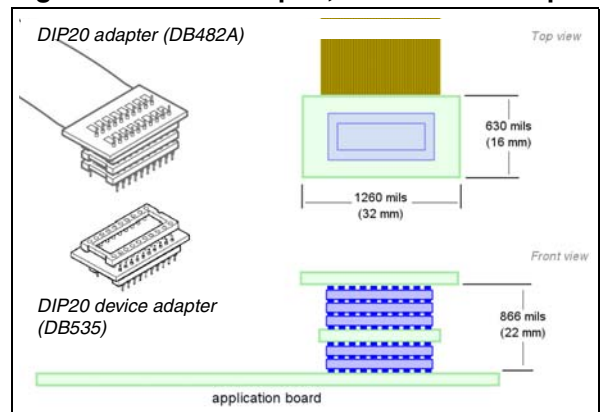
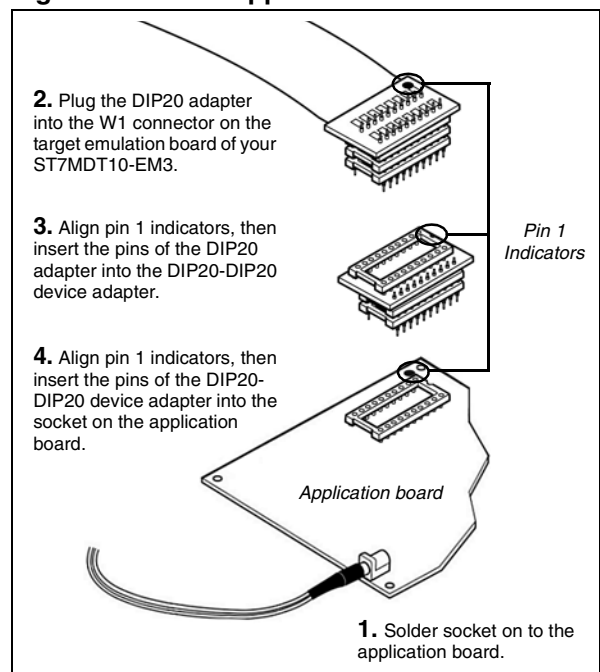
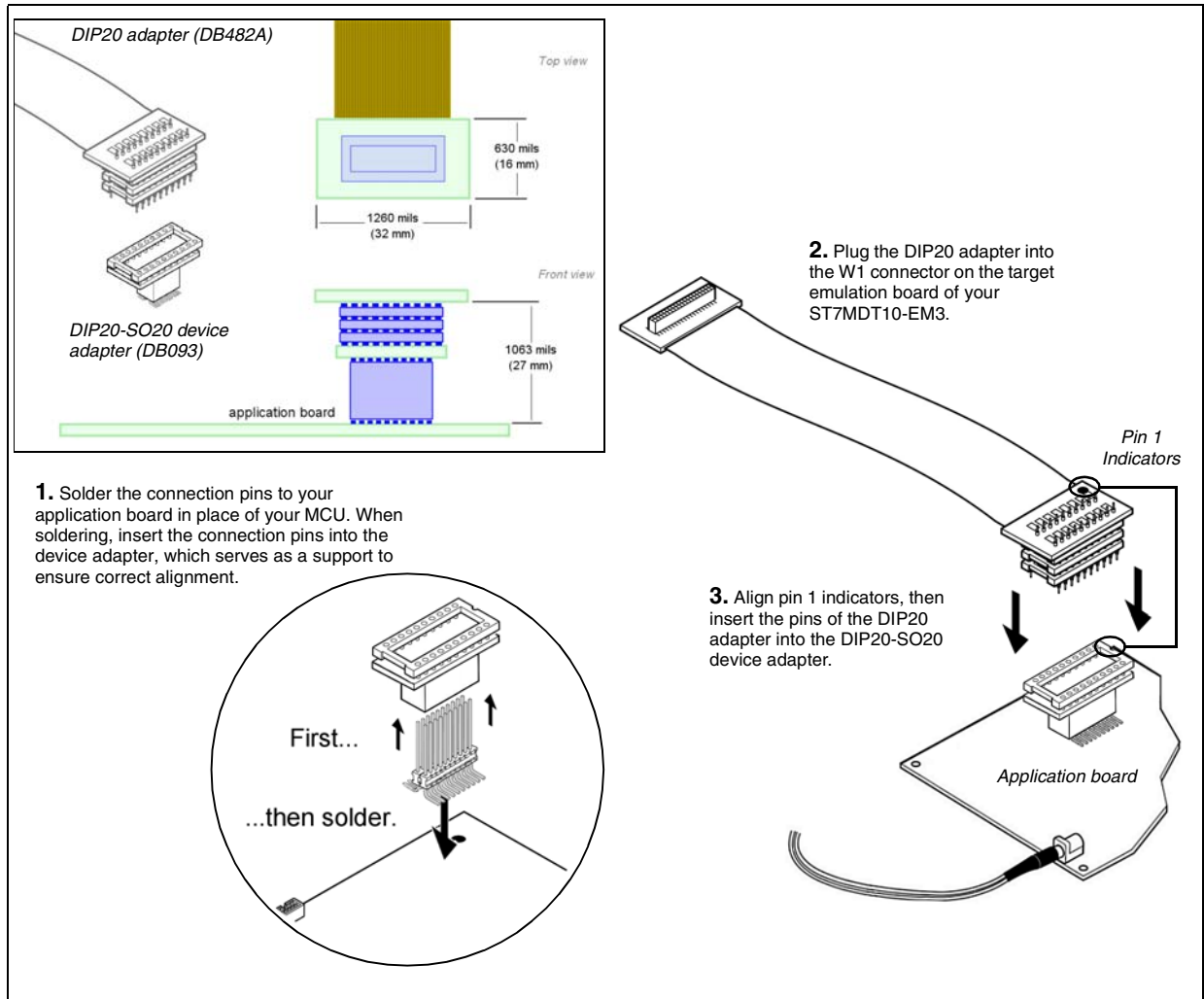

Figure 3. DIP20 application board connection



Note: The pinout on the DIP20 adapter is askew by 90° from the microcontroller. You use the DIP20 to DIP20 device adapter between the flex adapter and the socket on your application board when emulating MCUs in DIP20 package.

Figure 4. DIP20 adapter, SO20 device adapter and application board connection



Revision history

| Date | Revision | Changes |
|------------------|----------|------------------|
| 14-November-2005 | 1 | Initial release. |

Information furnished is believed to be accurate and reliable. However, STMicroelectronics assumes no responsibility for the consequences of use of such information nor for any infringement of patents or other rights of third parties which may result from its use. No license is granted by implication or otherwise under any patent or patent rights of STMicroelectronics. Specifications mentioned in this publication are subject to change without notice. This publication supersedes and replaces all information previously supplied. STMicroelectronics products are not authorized for use as critical components in life support devices or systems without express written approval of STMicroelectronics.

The ST logo is a registered trademark of STMicroelectronics.
All other names are the property of their respective owners

© 2005 STMicroelectronics - All rights reserved

STMicroelectronics group of companies

Australia - Belgium - Brazil - Canada - China - Czech Republic - Finland - France - Germany - Hong Kong - India - Israel - Italy - Japan -
Malaysia - Malta - Morocco - Singapore - Spain - Sweden - Switzerland - United Kingdom - United States of America

www.st.com

