



Chipsmall Limited consists of a professional team with an average of over 10 year of expertise in the distribution of electronic components. Based in Hongkong, we have already established firm and mutual-benefit business relationships with customers from,Europe,America and south Asia,supplying obsolete and hard-to-find components to meet their specific needs.

With the principle of “Quality Parts,Customers Priority,Honest Operation,and Considerate Service”,our business mainly focus on the distribution of electronic components. Line cards we deal with include Microchip,ALPS,ROHM,Xilinx,Pulse,ON,Everlight and Freescale. Main products comprise IC,Modules,Potentiometer,IC Socket,Relay,Connector.Our parts cover such applications as commercial,industrial, and automotives areas.

We are looking forward to setting up business relationship with you and hope to provide you with the best service and solution. Let us make a better world for our industry!



Contact us

Tel: +86-755-8981 8866 Fax: +86-755-8427 6832

Email & Skype: info@chipsmall.com Web: www.chipsmall.com

Address: A1208, Overseas Decoration Building, #122 Zhenhua RD., Futian, Shenzhen, China





FEATURES

- User-settable, visual alarm function
- Flashing display indicates overcurrent faults
- Measures the true-rms value of complex ac current waveforms
- Includes built-in current transformers
- Ideal for measuring current in sensitive IT applications
- Available in two input ranges: 0-30.0A, and 0 to 50A
- 50A model features convenient split-core CT
- Easy-to-read, red LED display with 0.37"/9.4mm high digits
- Two AC power options: 85-140Vac & 170-264Vac (50/60Hz)
- 2000V isolation between ac supply and load conductor

Murata Power Solutions' ACA-20RM-ALM Series digital ac ammeters accurately display the true-rms value of non-sinusoidal ac currents and provide a user-settable, over current alarm function. When the preset over current level is exceeded, the LED display continuously flashes from high to low intensity. All models are totally self-contained—no other user-supplied components are required. A built-in current transformer greatly simplifies most ac ammeter applications: just pass the load conductor through the built-in current transformer, apply ac power, and the ammeter is fully operational.

Two input ranges are available: 0-30.0 Amps, or 0 to 50.0 Amps, both with 0.1A resolution. The 50 Amp model features a convenient split-core type current transformer which can be clamped around insulated live conductors. Two power supply options are available: 85-140V (47-63Hz), and 170-264V (47-63Hz). Power consumption from a nominal 120V or 220V ac supply is less than 50mA. Super-stable components and an rms-to-dc converter circuit combine to achieve excellent performance when measuring the complex, non-sinusoidal, ac currents found in today's computer/telecom equipment.

All ACA-20RM-ALM Series true-rms ammeters feature full-size, 0.37" (9.4mm) high, 3½ digit, bright red LED-displays and a built-in bezel/filter assembly that includes metal fasteners. They are also panel cutout compatible with MPS's DMS-20RM Series of rms-reading ac voltage monitors, making ACA-20RM-ALM ammeters the ideal upgrade for today's sophisticated instrumentation.

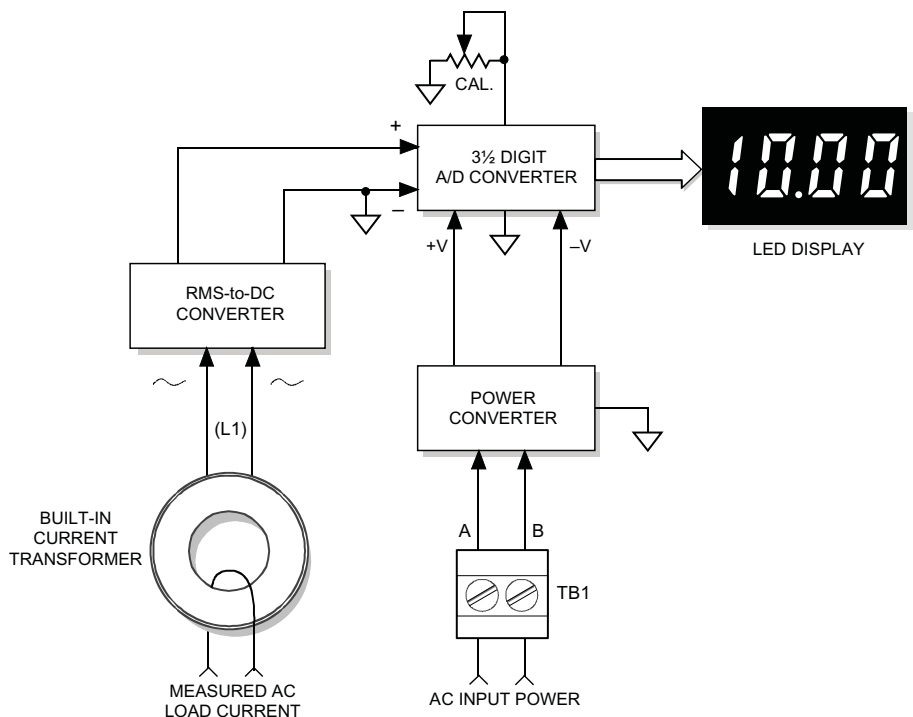

Figure 1. ACA-20RM-ALM Series simplified schematic



Performance/Functional Specifications

Typical at $T_A = +25^\circ\text{C}$, unless otherwise noted.

Rated Full-Scale Current ①	Min.	Typ.	Max.	Units
ACA-20RM-4-ACX-RL-ALM	—	—	50.0	Amperes
ACA-20RM-5-ACX-RL-ALM	—	—	30.0	Amperes
Overcurrent Rating ②	1.5 x Rated Full-Scale Current			
Performance				
Sampling Rate	2.5 Samples per second			
Accuracy ③	$\pm 0.4\%FS \pm 3$ Counts with 60Hz Sine-Wave Input			
Measurement Type	rms Responding, Crest Factors of 1-5			
Temperature Drift (0 to 60 °C)	—	± 0.2	± 0.4	Counts/°C
Zero-Current Reading (within 30 sec.)	-001	000	001	Counts
Dielectric Withstanding Voltage	2000	—	—	Vdc
Power Supply Voltage				
ACA-20RM-X-AC3-RL-ALM	85	120	140	Vac/47-63Hz
ACA-20RM-X-AC4-RL-ALM	170	220	264	Vac/47-63Hz
Power Supply Current ④				
ACA-20RM-X-AC3-RL-ALM	—	30	50	mA/47-63Hz
ACA-20RM-X-AC4-RL-ALM	—	30	50	mA/47-63Hz
Alarm Function				
Display indication	Flashing Display with actual current reading and display intensity change			
Settable range				
ACA-20RM-4-ACX-RL-ALM	13	45	50	Amps
ACA-20RM-5-ACX-RL-ALM	8	24	30	Amps
Power Supply Terminal Block				
Wire Size	16-22AWG, Solid or stranded			
Insulation Strip Length	0.250 inches			
Screw Tightening Torque	3.6 pounds-inches (0.4Nm)			
Rated Voltage	310Vac			
Display				
Display Type and Size	3½ Digit Red LED, 0.37"/9.4mm High			
Overrange Indication	"1 ___"			
Decimal Point	Fixed, model dependent (see full-scale input current)			
Physical/Environmental				
Operating Temperature	0	—	+60	°C
Storage Temperature	-40	—	+75	°C
Humidity (non-condensing)	0	—	85	%
Dimensions	Model dependent, see page 4 & 5			
Weight				
ACA-20RM-4-XXX-XX-ALM	1.5 Ounces (43 grams) nominal			
ACA-20RM-5-XXX-XX-ALM	2.1 Ounces (60 grams) nominal			

- ① Specified full-scale currents are those passing through the ammeter's built-in current transformer's primary load-circuit. See Notes 2 and 3 below for additional model-specific information.
- ② The overcurrent rating of 1.5 x the rated full-scale current is a continuous rating and applies to the current passing through the built in current transformer only, it does not apply to any external circuit-wiring or external loads. Accuracy is guaranteed up to the rated current level.
- ③ Specified accuracy applies to inputs with crest factors (CF) up to 2.0, where $CF = V_{peak}/V_{rms}$. Crest factors of 2 to 5 introduce an additional error of $\pm 3\%$ of full scale. Ammeters are calibrated with a near full-scale 60Hz sine-wave current flowing through the ammeter's built-in CT.
- ④ All specified maximum power supply currents are steady state; larger surge currents can occur at initial application of line power.

Ordering Information

ACA-20RM-4-AC3-RL-ALM-C	50.0A Range (split-core CT), 85-140Vac power
ACA-20RM-4-AC4-RL-ALM-C	50.0A Range (split core CT), 170-264Vac power
ACA-20RM-5-AC3-RL-ALM-C	30.0A Range, 85-140Vac power
ACA-20RM-5-AC4-RL-ALM-C	30.0A Range, 170-264Vac power

TECHNICAL NOTES

IMPORTANT! To ensure safe and reliable operation, ACA-20RM-ALM ammeters must be installed and serviced by qualified technical personnel. Contact Murata Power Solutions if there is any doubt regarding ammeter setup, installation, or operation.

- 1. Measurement Type:** ACA-20RM-ALM ac ammeters employ a true-rms input circuit to measure current flowing through L1. Stated accuracy specifications are measured using a sine-wave current at, or close to, the ammeter's full-scale input range, at nominal line frequency of 60Hz.
- 2. Calibration (Potentiometer R7):** Periodic recalibration of ACA-20RM-ALM ammeters is not required under normal, indoor operating environments. If user calibration is necessary, it must be performed by qualified technical personnel. Calibration is performed with potentially lethal voltages applied to the ACA-20RM-ALM and its associated wiring. A plastic, fully-insulated adjusting tool must be used to access the calibration potentiometer R7 located on the back of the ammeter (see 'Mechanical Specifications' section). Contact MPS if additional information is required regarding calibration, setup, or any other technical issue pertaining to ACA-20RM-ALM ammeters.
- 3. Overcurrent Alarm Setup and Adjustment (Potentiometer R3):** ACA-20RM-ALM ammeters feature a user-settable, overcurrent visual alarm indication which can be used to alert operators that a load circuit breaker or fuse is approaching an overload condition. When the load current sensed by L1 exceeds this preset level, the ammeter's LED display will flash from normal intensity to dim intensity at rate of approximately 1.5 times per second.

As shown in Figure 3, the alarm circuit consists of jumper JP1, and adjustment potentiometer R3. As shipped, R3 is factory set to trip when the load current is approximately 24 Amps for 30A models, and approximately 45 Amps for 50A models. When R3 is set to its maximum clockwise position, the alarm indication will not activate until the load current flowing through L1 exceeds the maximum rating of the ammeter, i.e., above 30.0A, or above 50.0A, depending on the model.

To adjust the overcurrent alarm set-point level:

- A. Turn off power to the ACA-20RM-ALM (i.e., the power source connected to TB1).
- B. Carefully remove the shorting jumper across JP1 from its 'normal operation position' across terminals 2 and 3 and place it across JP1 terminals 1 and 2.
- C. Re-apply power to TB1 and, using a plastic insulated adjusting tool, adjust R3 so the ammeter's display shows the desired overcurrent trip level in Amps.
- D. Turn off power to the ACA-20RM-ALM and return JP1's shorting jumper back to its 'normal operation position' across terminals 2 and 3. Re-apply power to TB1 to resume normal operation. If possible, after the ammeter is re-configured for normal operation, the load current should be slowly increased to verify the visual alarm operates when the load current exceeds the preset level.

Please note, the load circuit does not need to be turned off to adjust the overcurrent alarm set point. Current flowing through L1 while JP1 is across terminals 1 and 2 will not be measured. Once tripped, the alarm set point function has a hysteresis of approximately 0.5A.

The overcurrent alarm function can also be adjusted with JP1 in its normal operation position if the desired alarm overcurrent-level is actually flowing through L1 (i.e., with a live load). For example, with a 20 Amp load current flowing through L1, and with JP1 in its normal operation position, slowly adjust R3 until the display starts flashing on and off. Using this "live load" adjustment method eliminates the need to turn off power to TB1 or reconfiguring JP1.

4. **Wire Gauges and Fusing:** Wires specified in the Functional Specifications section must be used for making connections to ACA-20RM-ALM series ammeters. All power-supply and load wiring must be rated for the supply voltages and currents they will conduct and must comply with any code or application-mandated requirements pertaining to the user's specific installation.

ACA-20RM-ALM ammeters are not internally fused. Terminal block TB1 is to be used only for powering the ammeter's internal circuitry; it must not be used to supply power to external loads. The supply wires feeding these power meters must be fused with a 0.25A/250V time delay/time lag fuse, in accordance with applicable regulatory codes.

Wire insulation must be stripped to within $\pm 10\%$ of the stated dimensions, and wires should be inserted into TB1 such that their insulation is not pinched by the screw terminal.

5. **AC Supply Polarity and Grounding:** The two supply inputs, TB1-A and TB1-B, on ACA-20RM-ALM ammeters are not in themselves polarity sensitive, that is, they have no internal "AC LO" or "AC HI" designations. ACA-20RM-ALM ammeters do not include or require a connection to earth/chassis ground.
6. **Connector Torque Ratings:** It is important to tighten TB1's, screw-terminals to their rated torque specification of 3.6 pound-inches (0.4Nm). Proper tightening will minimize connector losses and ensure safe, reliable operation.

7. **Isolation:** The built-in current transformer L1 provides a minimum of 2000Vdc isolation between the load conductor and the ammeter's supply voltage connected to TB1.
8. **Split-Core CT (Clamp-on) Models:** Both 50A models feature a split-core current transformer that can be clamped around a properly insulated live conductor without having to disconnect or remove power from the load circuit. This live-connection capability can only be used if the load's power source is electrically isolated (see technical note 7) from the ammeter's own power source that's connected to TB1. The ammeter's ac power supply must always be deenergized before making connections to TB1. Refer to the 'Panel Installation' section of this data sheet for additional information.

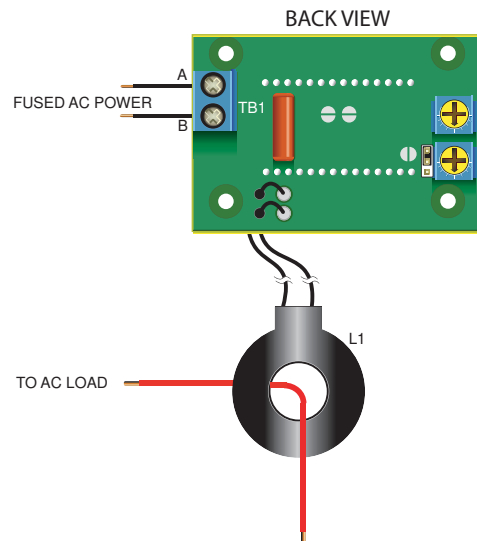

Figure 2. Typical wiring diagram

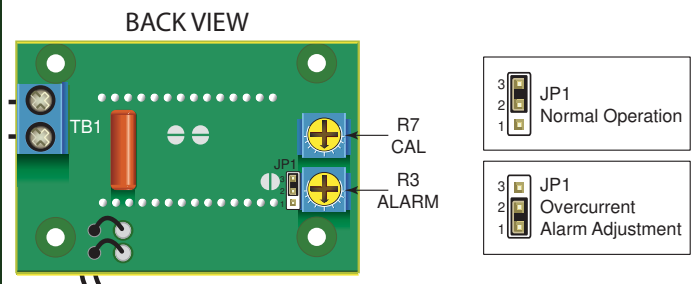

Figure 3. Alarm circuit component location

PANEL INSTALLATION

All connections to ACA-20RM-ALM Series ammeters must be made after the ammeter is securely attached to the panel and with all associated load and supply voltages de-energized (off), using extreme caution and observing all safety measures applicable to the user's installation.

Care should be exercised when passing conductors through the ammeter's built-in current transformer L1. The installed wire-positions should be such that minimal mechanical forces are applied to L1, TB1, or to the ammeter itself. In high-vibration environments, it is strongly recommended that adequate strain reliefs be used for all wiring.

Using Figure 4 as a guide, carefully insert the bezel/color filter assembly into the panel opening. From the rear of the panel, install the four round

plastic standoffs over the bezel's threaded studs. Install the ACA-20RM-ALM pc-board assembly as shown and then attach and securely tighten each of the four hex nuts to 15-20 ozf-in (0.106 to 0.140 N-m). Use only the factory-supplied hardware as the use of substitute hardware could result in an unsafe installation and/or adversely affect the reliability of the ammeter.

The recommended range of panel thickness that can be used with the supplied hardware is 0.040 inches (1.0mm) to 0.125 inches (3.2mm). Panel thickness outside of this range will require additional user-supplied hardware or modifications.

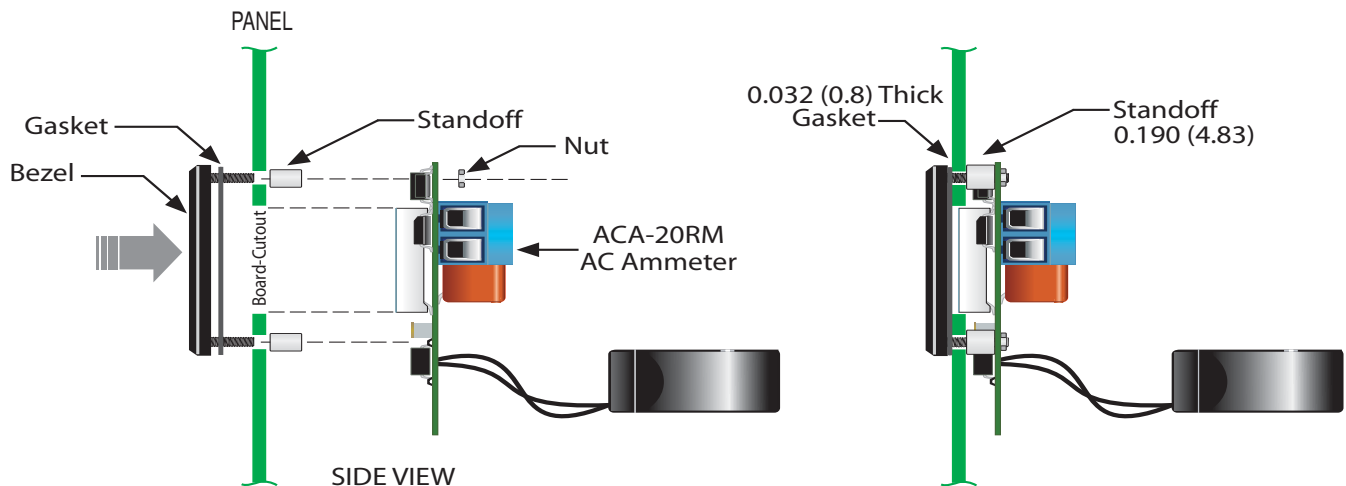
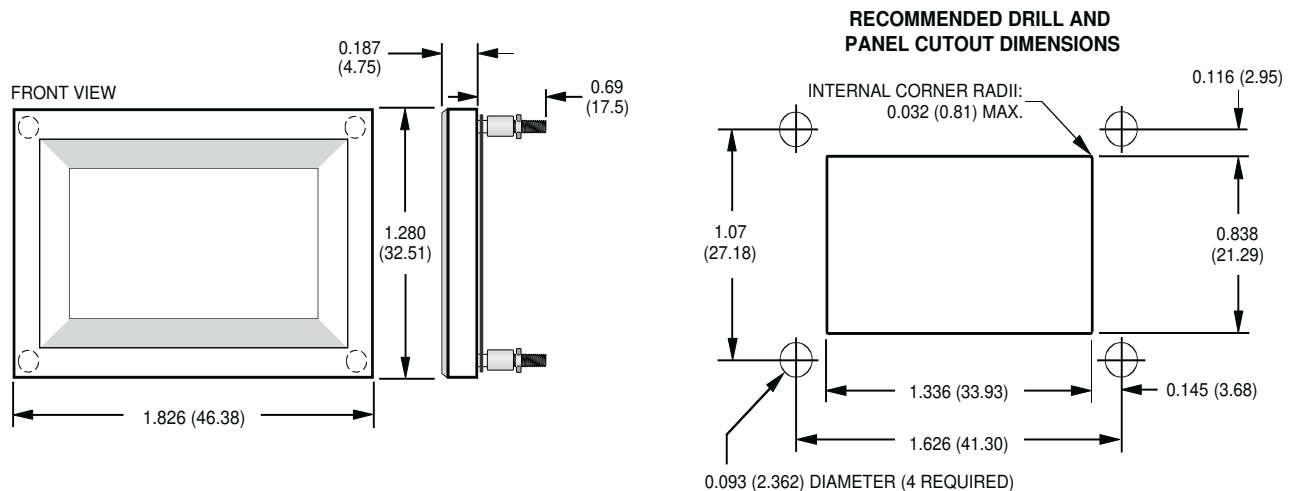
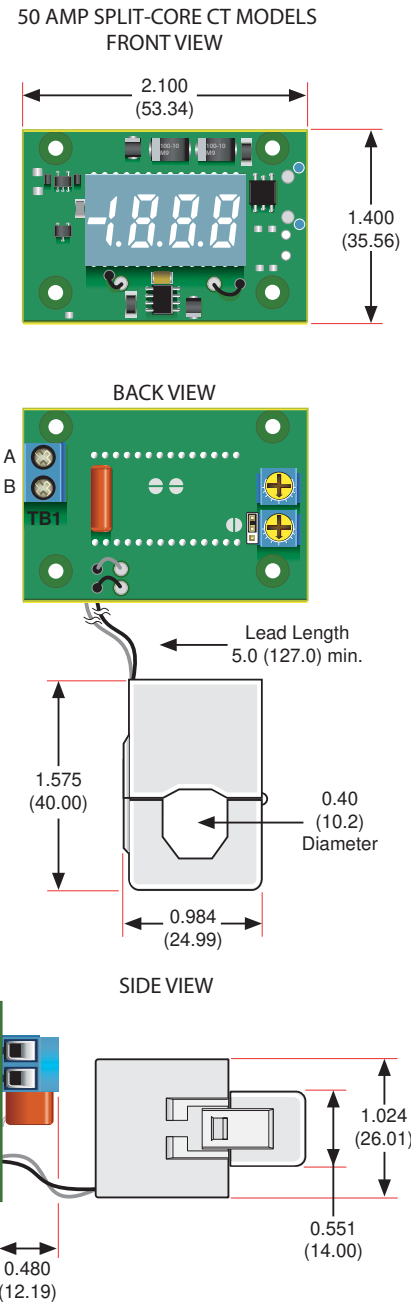
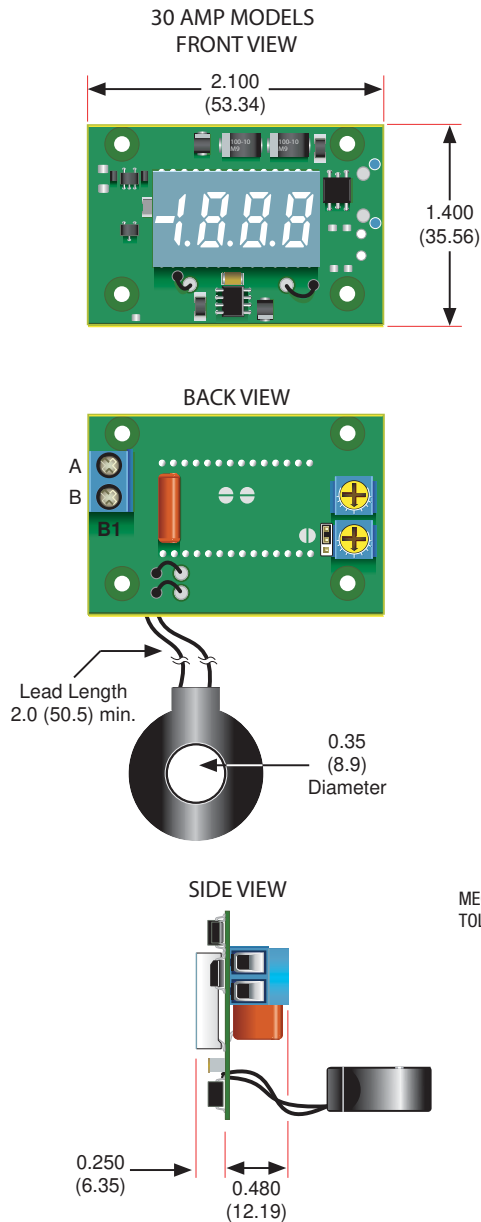

Figure 4. Panel Installation

BEZEL AND PANEL CUTOUT



MECHANICAL SPECIFICATIONS



MECHANICAL DIMENSIONS: Inches (mm)
 TOLERANCES: 2 PL DEC ± 0.02 (± 0.51)
 3 PL DEC ± 0.010 (± 0.254)

Murata Power Solutions, Inc.
 11 Cabot Boulevard, Mansfield, MA 02048-1151 U.S.A.
 ISO 9001 and 14001 REGISTERED

Murata Power Solutions, Inc. makes no representation that the use of its products in the circuits described herein, or the use of other technical information contained herein, will not infringe upon existing or future patent rights. The descriptions contained herein do not imply the granting of licenses to make, use, or sell equipment constructed in accordance therewith. Specifications are subject to change without notice. © 2012 Murata Power Solutions, Inc.