



Chipsmall Limited consists of a professional team with an average of over 10 year of expertise in the distribution of electronic components. Based in Hongkong, we have already established firm and mutual-benefit business relationships with customers from,Europe,America and south Asia,supplying obsolete and hard-to-find components to meet their specific needs.

With the principle of “Quality Parts,Customers Priority,Honest Operation,and Considerate Service”,our business mainly focus on the distribution of electronic components. Line cards we deal with include Microchip,ALPS,ROHM,Xilinx,Pulse,ON,Everlight and Freescale. Main products comprise IC,Modules,Potentiometer,IC Socket,Relay,Connector.Our parts cover such applications as commercial,industrial, and automotives areas.

We are looking forward to setting up business relationship with you and hope to provide you with the best service and solution. Let us make a better world for our industry!



Contact us

Tel: +86-755-8981 8866 Fax: +86-755-8427 6832

Email & Skype: info@chipsmall.com Web: www.chipsmall.com

Address: A1208, Overseas Decoration Building, #122 Zhenhua RD., Futian, Shenzhen, China



Automotive High-Speed, Low-Power Digital Optocoupler with R²Coupler® Isolation in a Stretched 12-Pin Surface Mount Plastic Package

Data Sheet

Description

The ACFL-6211T and ACFL-6212T are automotive grade dual channel, bi-directional, high speed digital CMOS optocouplers. The stretched SO-12 stretched package outline is designed to be compatible with standard surface mount processes and occupies the same land area as their single channel equivalent, ACPL-K71T and ACPL-K72T, in stretched SO8 package.

This digital optocoupler uses an insulating layer between the light emitting diode and an integrated photo detector to provide electrical insulation between input and output. Each channel of the digital optocoupler has a CMOS detector IC with an integrated photodiode, a high speed trans-impedance amplifier, and a voltage comparator with an output driver. Each channel is also isolated from the other.

Broadcom R²Coupler technology provides reinforced insulation and reliability that delivers safe signal isolation critical in automotive and high temperature industrial applications.

Functional Diagram

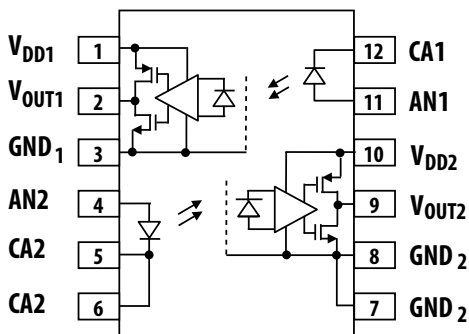

Truth Table

LED	OUTPUT
ON	LOW
OFF	HIGH

Note: The connection of a 1 μ F bypass capacitor between pins 1 and 3 and pins 8 and 10 is recommended.

CAUTION: It is advised that normal static precautions be taken in handling and assembly of this component to prevent damage and/or degradation which may be induced by ESD. The components featured in this datasheet are not to be used in military or aerospace applications or environments.

Features

- Qualified to AEC Q100 Grade 1 Test Guidelines
- Automotive Wide Temperature Range: -40°C to $+125^{\circ}\text{C}$
- 5V CMOS compatibility
- 40 kV/ μs Common-Mode Rejection at $V_{\text{CM}}=1000\text{V}$ (typ)
- Low Propagation Delay :
 - ACFL-6211T: 25 ns at $I_{\text{F}} = 10 \text{ mA}$ (typ)
 - ACFL-6212T: 60 ns at $I_{\text{F}} = 4 \text{ mA}$ (typ)
- Compact, Auto-Insertable Stretched SO12 Packages
- Worldwide Safety Approval:
 - UL 1577 recognized, 5 kV_{RMS}/1 min.
 - CSA Approved
 - IEC/EN/DIN EN 60747-5-5

Features

- Automotive IPM Driver for DC-DC converters and motor inverters
- CANBus and SPI Communications Interface
- High Temperature Digital/Analog Signal Isolation
- Power Transistor Isolation

Pin Description

Pin No.	Pin Name	Description
1	V _{DD1}	Primary Side Power Supply
2	V _{OUT1}	Output 1
3	GND1	Primary Side Ground
4	AN2	Anode 2
5	CA2	Cathode 2
6	CA2	Cathode 2

Pin No.	Pin Name	Description
7	GND2	Secondary Side Ground
8	GND2	Secondary Side Ground
9	V _{OUT2}	Output 2
10	V _{DD2}	Secondary Side Power Supply
11	AN1	Anode 1
12	CA1	Cathode 1

Ordering Information

Part Number	Option (RoHS Compliant)	Package	Surface Mount	Tape and Reel	UL 5000 Vrms/ 1 Minute rating	IEC/EN/DIN EN 60747-5-5	Quantity
ACFL-6211T	-000E	Stretched SO-12	X		X		80 per tube
	-060E		X		X	X	80 per tube
	-500E		X	X	X		1000 per reel
	-560E		X	X	X	X	1000 per reel
ACFL-6212T	-000E	Stretched SO-12	X		X		80 per tube
	-060E		X		X	X	80 per tube
	-500E		X	X	X		1000 per reel
	-560E		X	X	X	X	1000 per reel

To order, choose a part number from the part number column and combine with the desired option from the option column to form an order entry.

Example 1:

ACFL-6212T-560E to order product of SSO-12 Surface Mount package in Tape and Reel packaging with IEC/EN/DIN EN 60747-5-5 Safety Approval in RoHS compliant.

Option datasheets are available. Contact your Broadcom sales representative or authorized distributor for information.

Package Outline Drawing

12-Lead Surface Mount

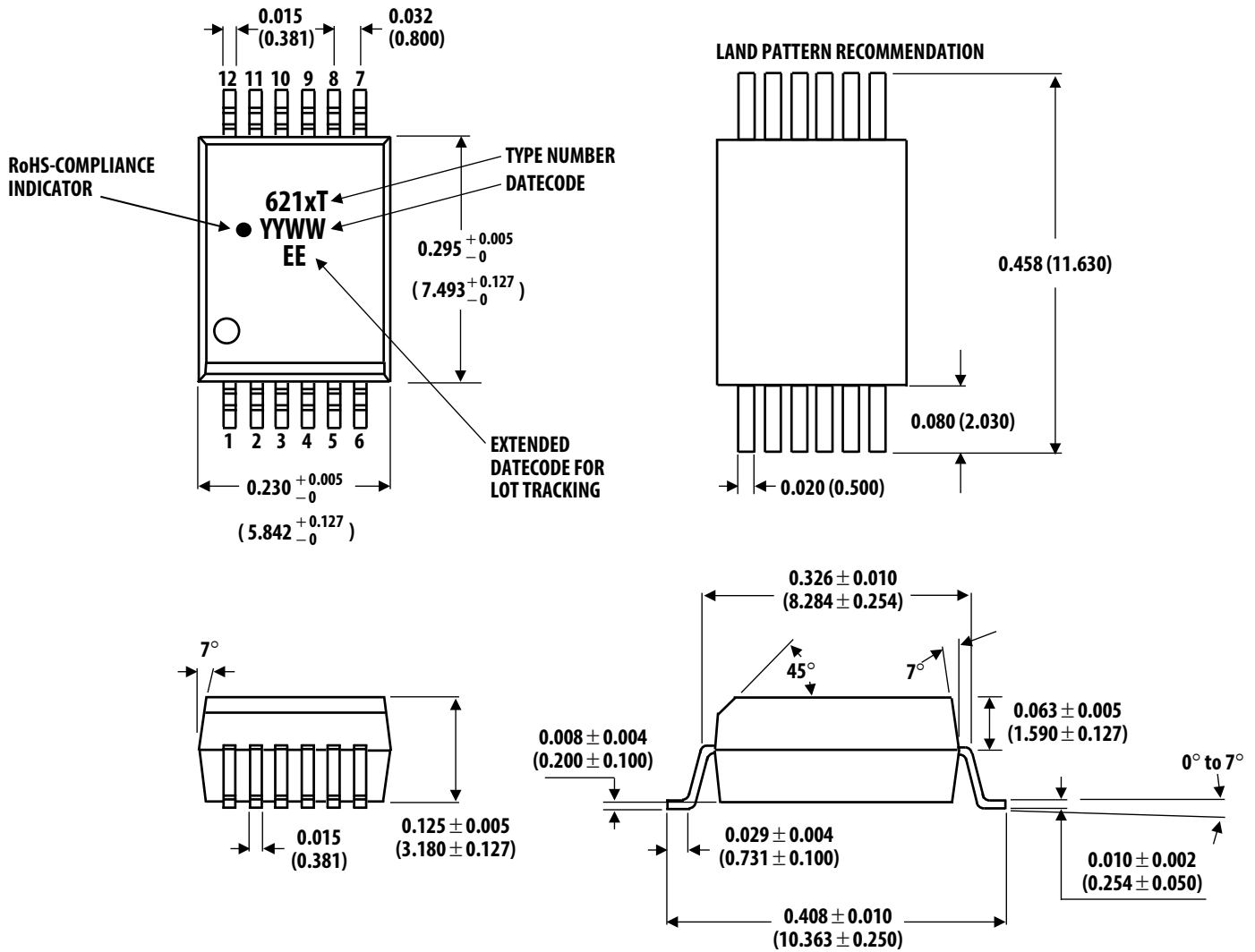

Dimensions in inches (millimeters)

Lead coplanarity = 0.004 inches (0.1 mm)

Recommended Pb-Free IR Profile

Recommended reflow condition as per JEDEC Standard, J-STD-020 (latest revision).

Note: Non-halide flux should be used

Regulatory Information

The ACFL-6211T and ACFL-6212T are approved by the following organizations:

UL	UL 1577, component recognition program up to $V_{ISO} = 5 \text{ kV}_{RMS}$
CSA	Approved under CSA Component Acceptance Notice #5
IEC/EN/DIN EN 60747-5-5	Approved under IEC/EN/DIN EN 60747-5-5

Insulation and Safety Related Specifications

Parameter	Symbol	ACFL-6211T/ ACFL-6212T	Unit	Conditions
Minimum External Air Gap (Clearance)	L(101)	8.3	mm	Measured from input terminals to output terminals, shortest distance through air.
Minimum External Tracking (Creepage)	L(102)	8.5	mm	Measured from input terminals to output terminals, shortest distance path along body.
Minimum Internal Plastic Gap (Internal Clearance)		0.08	mm	Through insulation distance conductor to conductor, usually the straight line distance thickness between the emitter and detector.
Tracking Resistance (Comparative Tracking Index)	CTI	175	V	DIN IEC 112/VDE 0303 Part 1
Isolation Group (DIN VDE0109)		IIIa		Material Group (DIN VDE 0109)

IEC/EN/DIN EN 60747-5-5 Insulation Related Characteristic (Option 060E and 560E)

Description	Symbol	Characteristic	Unit
Installation classification per DIN VDE 0110/1.89, Table 1 for rated mains voltage $\leq 600V_{RMS}$ for rated mains voltage $< 1000V_{RMS}$		I-III I-III	
Climatic Classification		40/125/21	
Pollution Degree (DIN VDE 0110/1.89)		2	
Maximum Working Insulation Voltage	V_{IORM}	1140	V_{PEAK}
Input to Output Test Voltage, Method b $V_{IORM} \times 1.875 = V_{PR}$, 100% Production Test with $t_m = 1 \text{ sec}$, Partial Discharge $< 5 \text{ pC}$	V_{PR}	2137	V_{PEAK}
Input to Output Test Voltage, Method a $V_{IORM} \times 1.6 = V_{PR}$, Type and sample test, $t_m = 10 \text{ sec}$, Partial Discharge $< 5 \text{ pC}$	V_{PR}	1824	V_{PEAK}
Highest Allowable Overvoltage (Transient Overvoltage, $t_{ini} = 60 \text{ sec}$)	V_{IOTM}	6000	V_{PEAK}
Safety Limiting Values (Maximum values allowed in the event of a failure)			
Case Temperature	T_S	175	$^{\circ}\text{C}$
Input Current	$I_{S,INPUT}$	230	mA
Output Power	$P_{S,OUTPUT}$	600	mW
Insulation Resistance at T_S , $V_{IO} = 500V$	R_S	10^9	Ω

Absolute Maximum Ratings

Parameter	Symbol	Min.	Max.	Unit	Condition
Storage Temperature	T_S	-55	+150	°C	
Ambient Operating Temperature ^[1]	T_A	-40	+125	°C	
Junction Temperature	T_J		+150	°C	
Supply Voltages	V_{DD}	0	6.5	V	
Output Voltage	V_O	-0.5	$V_{DD} + 0.5$	V	
Average Forward Input Current	I_F		20.0	mA	
Peak Transient Input Current (I_F at 1 μ s pulse width, <10% duty cycle)	$I_{F(TRAN)}$		1 80	A mA	$\leq 1 \mu$ s Pulse Width, 300 pps $\leq 1 \mu$ s Pulse Width, <10% Duty Cycle
Reverse Input Voltage	V_r		5	V	
Input Power Dissipation	P_I		40	mW	
Average Output Current	I_O		10	mA	
Output Power Dissipation	P_O		30	mW	
Lead Solder Temperature	260°C for 10 sec., 1.6 mm below seating plane				
Solder Reflow Temperature Profile	See Solder Reflow Temperature Profile Section				

Recommended Operating Conditions

Parameter	Symbol	Min.	Max.	Unit	Note
Supply Voltage	V_{DD}	3.0	5.5	V	
Operating Temperature	T_A	-40	+125	°C	
Forward Input Current	$I_{F(ON)}$	4.0	15	mA	
Forward Off State Voltage	$V_{F(OFF)}$		0.8	V	
Input Threshold Current	I_{TH}		3.5	mA	

Electrical Specifications

Over recommended operating conditions. All typical specifications are at $T_A = 25^\circ\text{C}$, $V_{DD} = 5\text{V}$.

Parameter	Symbol	Min.	Typ.	Max.	Unit	Test Conditions	Fig.
LED Forward Voltage	V_F	1.45	1.5	1.75	V	$I_F = 10 \text{ mA}$, $T_A = 25^\circ\text{C}$	
		1.25	1.5	1.85	V	$I_F = 10 \text{ mA}$	
VF Temperature Coefficient			-1.5		mV/°C		
Input Threshold Current	I_{TH}		1.3	3.5	mA		2
Input Capacitance	C_{IN}		90		pF		
Input Reverse Breakdown Voltage	BV_R	5.0			V	$I_R = 10 \mu\text{A}$	
Logic High Output Voltage	V_{OH}	$V_{DD} - 0.6$			V	$I_{OH} = -3.2 \text{ mA}$	4
Logic Low Output Voltage	V_{OL}			0.6	V	$I_{OL} = 4 \text{ mA}$	3
Logic Low Output Supply Current (per channel)	I_{DDL}		0.9	1.5	mA		
Logic High Output Supply Current (per channel)	I_{DDH}		0.9	1.5	mA		

ACFL-6211T High Speed Mode Switching Specifications

Over recommended operating conditions: $T_A = -40^{\circ}\text{C}$ to $+125^{\circ}\text{C}$, $4.5\text{V} \leq V_{DD} \leq 5.5\text{V}$. All typical specifications are at $T_A = 25^{\circ}\text{C}$, $V_{DD} = 5\text{V}$.

Parameter	Symbol	Min.	Typ.	Max.	Unit	Test Conditions	Fig.	Note
Propagation Delay Time to Logic Low Output	t_{PHL}		25	35	ns	$V_{in} = 4.5\text{V}$ to 5.5V , $R_{in} = 390\Omega \pm 5\%$, $C_{in} = 100\text{ pF}$, $C_L = 15\text{ pF}$ Output low threshold = 0.8V Output high threshold = 80% of V_{DD}	5, 9, 11	1, 2, 3
Propagation Delay Time to Logic High Output	t_{PLH}		25	35	ns			
Pulse Width Distortion	PWD		0	12	ns			
Propagation Delay Skew	t_{PSK}			15	ns			
Output Rise Time (10% to 90%)	t_R		10		ns			
Output Fall Time (90% to 10%)	t_F		10		ns			
Common Mode Transient Immunity at Logic High Output	$ CM_H $	15	25		kV/ μs	$V_{in} = 0\text{V}$, $R_{in} = 390\Omega \pm 5\%$, $C_{in} = 100\text{ pF}$, $V_{cm} = 1000\text{V}$, $T_A = 25^{\circ}\text{C}$		4
Common Mode Transient Immunity at Logic High Output	$ CM_L $	15	25		kV/ μs	$V_{in} = 4.5\text{V}$ to 5.5V , $R_{in} = 390\Omega \pm 5\%$, $C_{in} = 100\text{ pF}$, $V_{cm} = 1000\text{V}$, $T_A = 25^{\circ}\text{C}$		5

ACFL-6212T Low Power Mode Switching Specifications

Over recommended operating conditions: $T_A = -40^{\circ}\text{C}$ to $+125^{\circ}\text{C}$, $3.0\text{V} \leq V_{DD} \leq 5.5\text{V}$. All typical specifications at 25°C and $V_{DD} = 5\text{V}$.

Parameter	Symbol	Min.	Typ.	Max.	Unit	Test Conditions	Fig.	Note
Propagation Delay Time to Logic Low Output	t_{PHL}		60	100	ns	$I_F = 4\text{ mA}$, $C_L = 15\text{ pF}$	7, 12	1, 2, 3
Propagation Delay Time to Logic High Output	t_{PLH}		35	100	ns			
Pulse Width Distortion	PWD		25	50	ns			
Propagation Delay Skew	t_{PSK}			60	ns			
Output Rise Time (10% to 90%)	t_R		10		ns			
Output Fall Time (90% to 10%)	t_F		10		ns			
Common Mode Transient Immunity at Logic High Output	$ CM_H $	25	40		kV/ μs	Using Broadcom LED Driving Circuit, $V_{IN} = 0\text{V}$, $R_1 = 330\Omega \pm 5\%$, $R_2 = 330\Omega \pm 5\%$, $V_{CM} = 1000\text{V}$, $T_A = 25^{\circ}\text{C}$		4
Common Mode Transient Immunity at Logic Low Output	$ CM_L $	25	40		kV/ μs	Using Broadcom LED Driving Circuit, $V_{IN} = 4.5$ to 5.5V , $R_1 = 330\Omega \pm 5\%$, $R_2 = 330\Omega \pm 5\%$, $V_{CM} = 1000\text{V}$, $T_A = 25^{\circ}\text{C}$		5

Package Characteristics

All Typical at $T_A = 25^\circ\text{C}$.

Parameter	Symbol	Min.	Typ.	Max.	Unit	Test Conditions	Notes
Input-Output Momentary Withstand Voltage	V_{ISO}	5000			V_{RMS}	$RH \leq 50\%$, $t = 1 \text{ min.}$ $T_A = 25^\circ\text{C}$	6, 7
Input-Output Resistance	R_{I-O}		10^{14}		W	$V_{I-O} = 500V_{dc}$	6
Input-Output Capacitance	C_{I-O}		0.6		pF	$f = 1 \text{ MHz}$, $T_A = 25^\circ\text{C}$	6

Notes:

- t_{PHL} propagation delay is measured from the 50% (V_{IN} or I_F) on the rising edge of the input pulse to the 0.8V of V_{DD} of the falling edge of the V_O signal. t_{PLH} propagation delay is measured from the 50% (V_{IN} or I_F) on the falling edge of the input pulse to the 80% level of the rising edge of the V_O signal.
- PWD is defined as $|t_{PHL} - t_{PLH}|$.
- t_{PSK} is equal to the magnitude of the worst case difference in t_{PHL} and/or t_{PLH} that will be seen between units at any given temperature within the recommended operating conditions.
- CM_H is the maximum tolerable rate of rise of the common mode voltage to assure that the output will remain in a high logic state.
- CM_L is the maximum tolerable rate of fall of the common mode voltage to assure that the output will remain in a low logic state.
- Device considered a two terminal device: pins 1 to 6 shorted together, and pins 7 to 12 shorted together.
- In accordance with UL 1577, each optocoupler is proof tested by applying an insulation test voltage $> 6000V_{RMS}$ for 1 second.

Typical Performance Plots

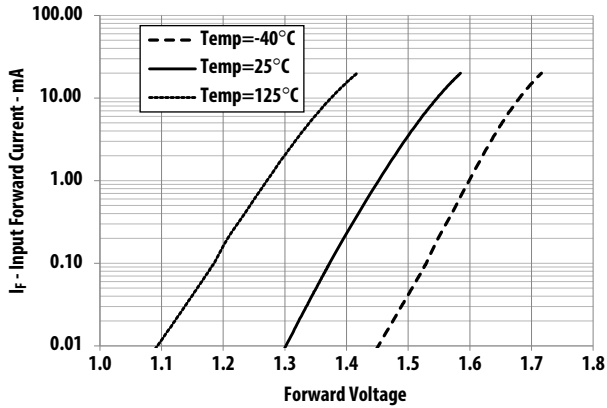

Figure 1: Typical Diode Input Forward Current Characteristic

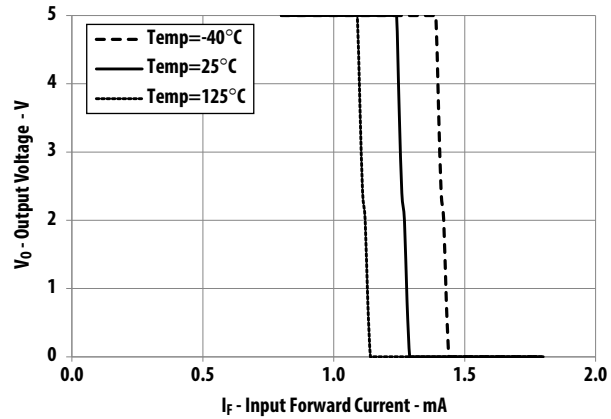

Figure 2: Typical Output Voltage vs. Input Forward Current

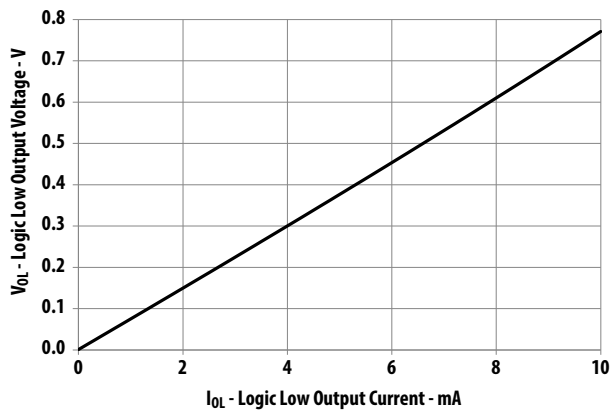

Figure 3: Typical Logic Low Output Voltage vs. Logic Low Output Current

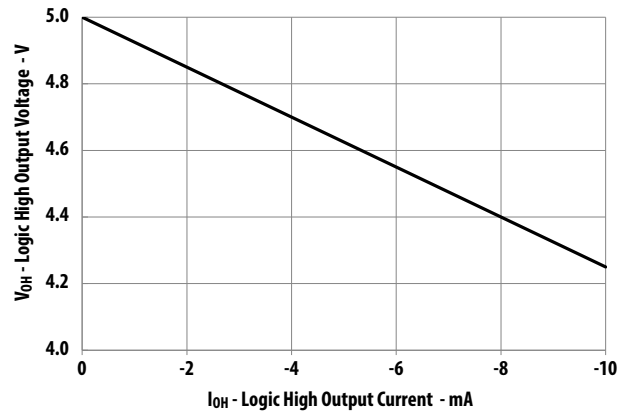

Figure 4: Typical Logic High Output Voltage vs. Logic High Output Current

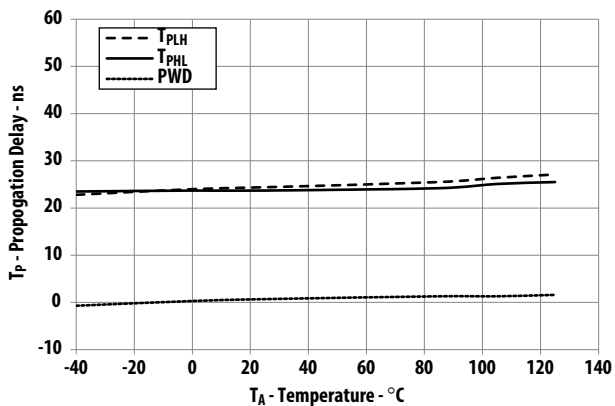

Figure 5: ACFL-6211T (High Speed) Typical Propagation Delay vs. Temperature, $V_{IN}=4.5V$, $R_{IN}=390\Omega$, $C_{IN}=100\text{ pF}$

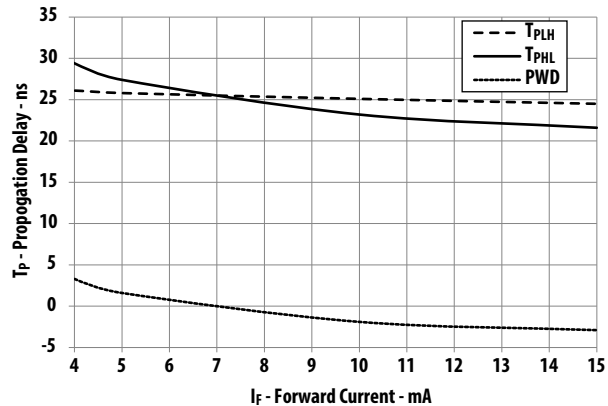

Figure 6: ACFL-6211T (High Speed) Typical Propagation Delay vs. Input Forward Current, $V_{IN}=4.5V$, $R_{IN}=390\Omega$, $C_{IN}=100\text{ pF}$, $T_A=25^\circ\text{C}$

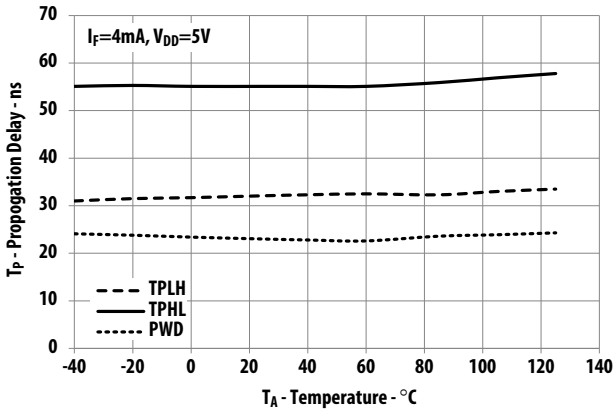

Figure 7. ACFL-6212T (5V) Typical Propagation Delay vs. Temperature

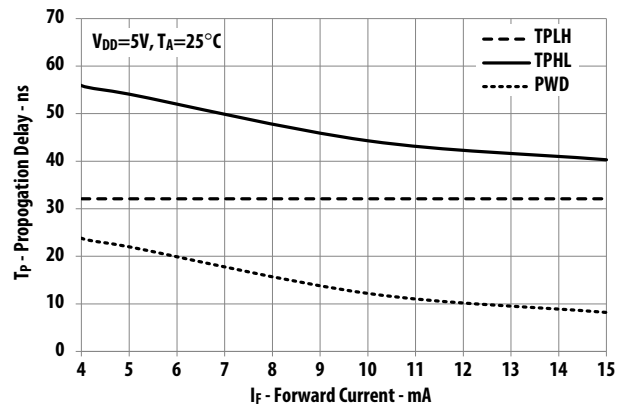

Figure 8. ACFL-6212T (5V) Typical Propagation Delay vs. Input Forward Current

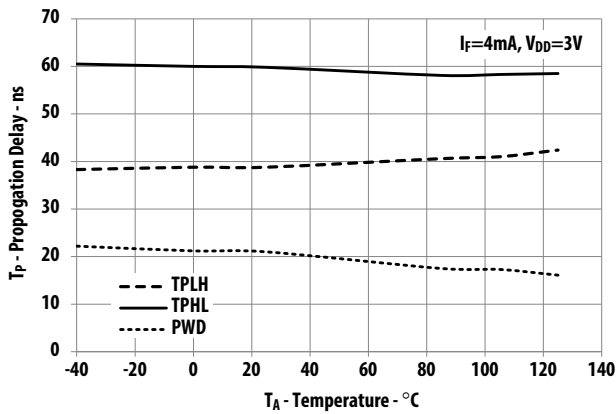

Figure 9. ACFL-6212T (3V) Typical Propagation Delay vs. Temperature

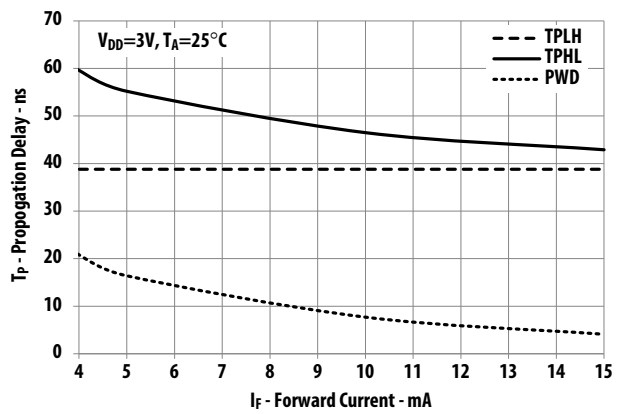
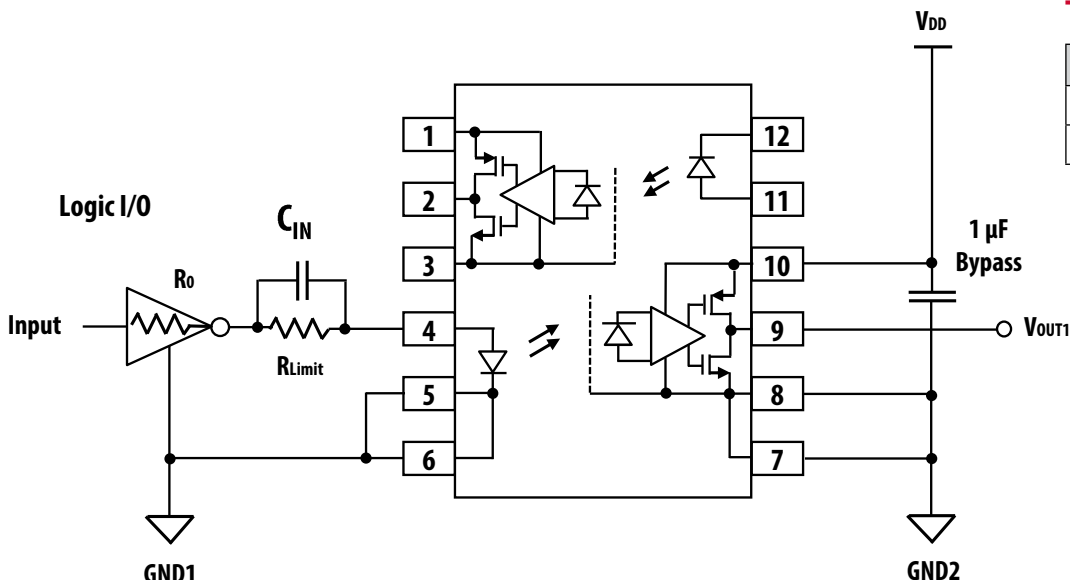

Figure 10. ACFL-6212T (3V) Typical Propagation Delay vs. Input Forward Current

Application Circuits



TRUTH TABLE

INPUT	LED	OUTPUT
L	ON	L
H	OFF	H

Figure 11: Recommended Application Circuit for ACFL-6211T High Speed Performance

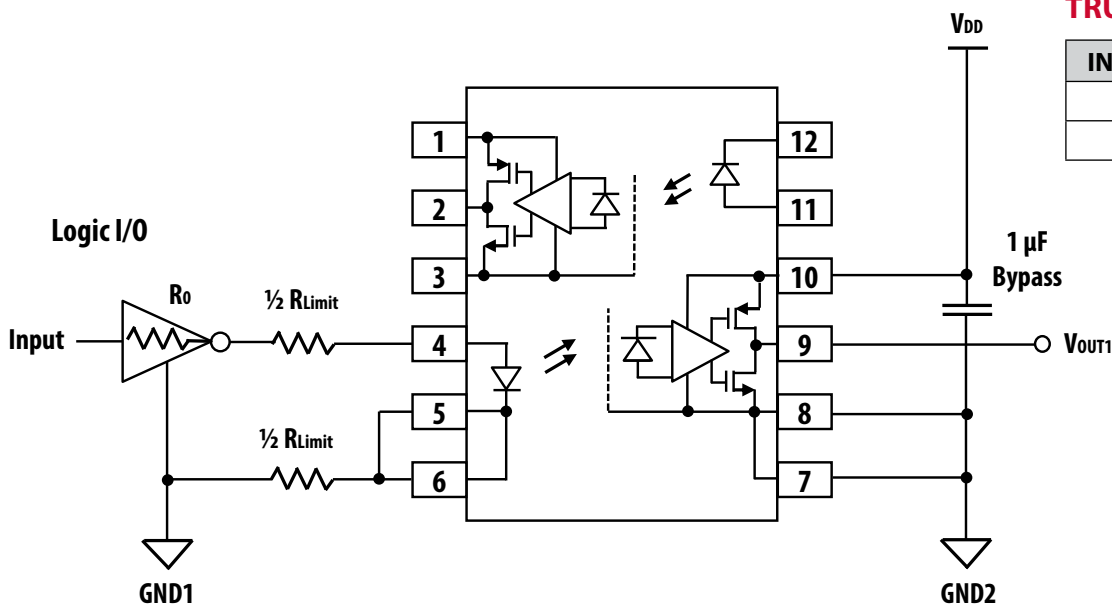

TRUTH TABLE

INPUT	LED	OUTPUT
L	ON	L
H	OFF	H

*C_i is Approximately 15 pF, which includes Probe and Stray Wiring Capacitance

Figure 12: Recommended Application Circuit for ACFL-6212T Low Power Performance

Test Circuits

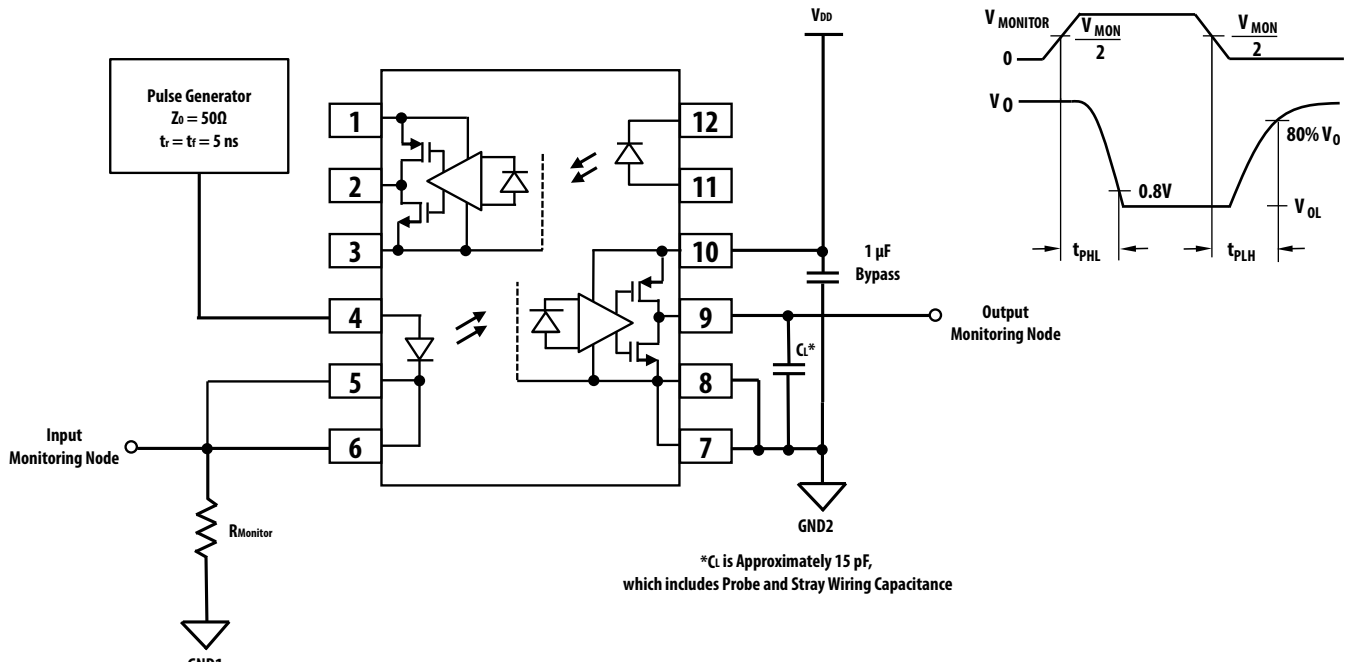

Figure 13: Test Circuit for t_{PHL} , t_{PLH} , t_{F} , and t_{R}

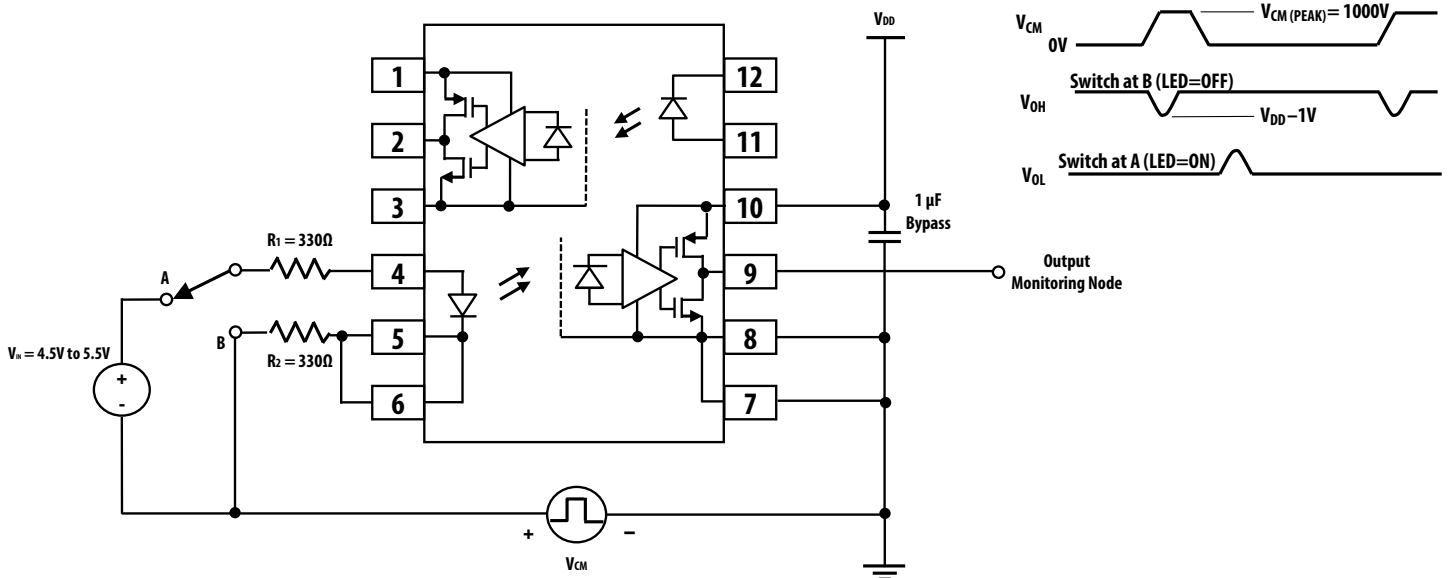

Figure 14: Test Circuit for Common Mode Transient Immunity

Thermal Resistance Measurement

The diagram of ACFL-6211T/6212T for measurement is shown in Figure 15. This is a multi-chip package with four heat sources, the effect of heating of one die due to the adjacent dice are considered by applying the theory of linear superposition. Here, one die is heated first and the temperatures of all the dice are recorded after thermal equilibrium is reached. Then, the second die is heated and all the dice temperatures are recorded and so on until the fourth die is heated. With the known ambient temperature, the die junction temperature and power dissipation, the thermal resistance can be calculated. The thermal resistance calculation can be cast in matrix form. This yields a 4x4 matrix for our case of two heat sources.

$$\begin{vmatrix} R_{11} & R_{12} & R_{13} & R_{14} \\ R_{21} & R_{22} & R_{23} & R_{24} \\ R_{31} & R_{32} & R_{33} & R_{34} \\ R_{41} & R_{42} & R_{43} & R_{44} \end{vmatrix} \times \begin{vmatrix} P_1 \\ P_2 \\ P_3 \\ P_4 \end{vmatrix} = \begin{vmatrix} \Delta T_1 \\ \Delta T_2 \\ \Delta T_3 \\ \Delta T_4 \end{vmatrix}$$

R₁₁: Thermal Resistance of Die1 due to heating of Die1 (°C/W)
 R₁₂: Thermal Resistance of Die1 due to heating of Die2 (°C/W)
 R₁₃: Thermal Resistance of Die1 due to heating of Die3 (°C/W)
 R₁₄: Thermal Resistance of Die1 due to heating of Die4 (°C/W)

R₂₁: Thermal Resistance of Die2 due to heating of Die1 (°C/W)
 R₂₂: Thermal Resistance of Die2 due to heating of Die2 (°C/W)
 R₂₃: Thermal Resistance of Die2 due to heating of Die3 (°C/W)
 R₂₄: Thermal Resistance of Die2 due to heating of Die4 (°C/W)

R₃₁: Thermal Resistance of Die3 due to heating of Die1 (°C/W)
 R₃₂: Thermal Resistance of Die3 due to heating of Die2 (°C/W)
 R₃₃: Thermal Resistance of Die3 due to heating of Die3 (°C/W)
 R₃₄: Thermal Resistance of Die3 due to heating of Die4 (°C/W)

R₄₁: Thermal Resistance of Die4 due to heating of Die1 (°C/W)
 R₄₂: Thermal Resistance of Die4 due to heating of Die2 (°C/W)
 R₄₃: Thermal Resistance of Die4 due to heating of Die3 (°C/W)
 R₄₄: Thermal Resistance of Die4 due to heating of Die4 (°C/W)

P₁: Power dissipation of Die1 (W)
 P₂: Power dissipation of Die2 (W)
 P₃: Power dissipation of Die3 (W)
 P₄: Power dissipation of Die4 (W)

T₁: Junction temperature of Die1 due to heat from all dice (°C)
 T₂: Junction temperature of Die2 due to heat from all dice (°C)
 T₃: Junction temperature of Die3 due to heat from all dice (°C)
 T₄: Junction temperature of Die4 due to heat from all dice (°C)

T_a: Ambient temperature.

ΔT₁: Temperature difference between Die1 junction and ambient (°C)

ΔT₂: Temperature difference between Die2 junction and ambient (°C)

ΔT₃: Temperature difference between Die3 junction and ambient (°C)

ΔT₄: Temperature difference between Die4 junction and ambient (°C)

$$T_1 = (R_{11} \times P_1 + R_{12} \times P_2 + R_{13} \times P_3 + R_{14} \times P_4) + T_a \text{ -- (1)}$$

$$T_2 = (R_{21} \times P_1 + R_{22} \times P_2 + R_{23} \times P_3 + R_{24} \times P_4) + T_a \text{ -- (2)}$$

$$T_3 = (R_{31} \times P_1 + R_{32} \times P_2 + R_{33} \times P_3 + R_{34} \times P_4) + T_a \text{ -- (3)}$$

$$T_4 = (R_{41} \times P_1 + R_{42} \times P_2 + R_{43} \times P_3 + R_{44} \times P_4) + T_a \text{ -- (4)}$$

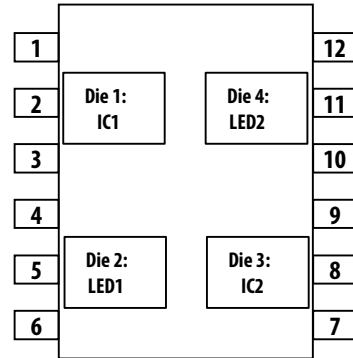

Figure 15: Diagram of ACFL-6211T/6212T for Measurement

Measurement data on a low K (conductivity) board:

R₁₁ = 181 °C/W
 R₂₁ = 103 °C/W
 R₃₁ = 82 °C/W
 R₄₁ = 110 °C/W
 R₁₂ = 91 °C/W
 R₂₂ = 232 °C/W
 R₃₂ = 97 °C/W
 R₄₂ = 86 °C/W
 R₁₃ = 85 °C/W
 R₂₃ = 109 °C/W
 R₃₃ = 180 °C/W
 R₄₃ = 101 °C/W
 R₁₄ = 112 °C/W
 R₂₄ = 91 °C/W
 R₃₄ = 91 °C/W
 R₄₄ = 277 °C/W

Measurement data on a high K (conductivity) board:

R₁₁ = 117 °C/W
 R₂₁ = 37 °C/W
 R₃₁ = 35 °C/W
 R₄₁ = 47 °C/W
 R₁₂ = 42 °C/W
 R₂₂ = 161 °C/W
 R₃₂ = 53 °C/W
 R₄₂ = 30 °C/W
 R₁₃ = 32 °C/W
 R₂₃ = 39 °C/W
 R₃₃ = 114 °C/W
 R₄₃ = 29 °C/W
 R₁₄ = 60 °C/W
 R₂₄ = 33 °C/W
 R₃₄ = 34 °C/W
 R₄₄ = 189 °C/W

For product information and a complete list of distributors, please go to our web site:
www.broadcom.com.



Broadcom, the pulse logo, Connecting everything, Avago Technologies, Avago, the A logo, and R²Coupler are among the trademarks of Broadcom and/or its affiliates in the United States, certain other countries and/or the EU.

Broadcom Proprietary and Confidential. Copyright © 2017 Broadcom. All Rights Reserved. The term "Broadcom" refers to Broadcom Limited and/or its subsidiaries.

Broadcom reserves the right to make changes without further notice to any products or data herein to improve reliability, function, or design. Information furnished by Broadcom is believed to be accurate and reliable. However, Broadcom does not assume any liability arising out of the application or use of this information, nor the application or use of any product or circuit described herein, neither does it convey any license under its patent rights nor the rights of others.
AV02-4835EN – April 18, 2017