



Chipsmall Limited consists of a professional team with an average of over 10 year of expertise in the distribution of electronic components. Based in Hongkong, we have already established firm and mutual-benefit business relationships with customers from,Europe,America and south Asia,supplying obsolete and hard-to-find components to meet their specific needs.

With the principle of “Quality Parts,Customers Priority,Honest Operation,and Considerate Service”,our business mainly focus on the distribution of electronic components. Line cards we deal with include Microchip,ALPS,ROHM,Xilinx,Pulse,ON,Everlight and Freescale. Main products comprise IC,Modules,Potentiometer,IC Socket,Relay,Connector.Our parts cover such applications as commercial,industrial, and automotives areas.

We are looking forward to setting up business relationship with you and hope to provide you with the best service and solution. Let us make a better world for our industry!



Contact us

Tel: +86-755-8981 8866 Fax: +86-755-8427 6832

Email & Skype: info@chipsmall.com Web: www.chipsmall.com

Address: A1208, Overseas Decoration Building, #122 Zhenhua RD., Futian, Shenzhen, China



ACFM-7037

Band 3/Band 7 Quadplexer

Product Brief

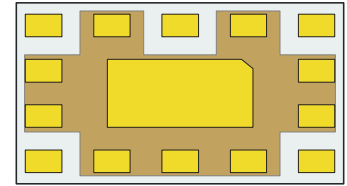

Description

The Avago Technologies' ACFM-7037 is a quadplexer that combines Band 3 and Band 7 duplexers into a single, miniature package.

The ACFM-7037 features a single antenna connection, which eliminates the need for antenna switching. All ports are matched to 50 ohms.

The ACFM-7037 is designed with Avago Technologies' film bulk acoustic resonator (FBAR) technology. The ACFM-7037 also utilizes Avago Technologies' innovative microcap bonded-wafer, chip scale packaging technology. This process allows the filters to be assembled in a module with a footprint of only 3.6 mm × 2 mm with a maximum height of 0.80 mm.

Low Tx insertion loss of the ACFM-7037 reduces power amplifier current, which extends battery life. The ACFM-7037 enhances receiver sensitivity and dynamic range with low Rx insertion loss and high rejection of Tx signals at the Rx ports.

The excellent power handling capability of Avago Technologies' FBAR bulk-mode resonators supports the high Tx output power levels needed mobile communications devices while adding virtually no distortion.

Features

- Single antenna
- Band 3 and Band 7 carrier aggregation
- Miniature size
 - 3.6 mm × 2 mm footprint
 - 0.80 mm maximum height
- High power rating
 - +31 dBm maximum Tx power
- Environmental
 - RoHS 6 compliant
 - Halogen free
 - TBBPA free

Applications

Smartphones, tablets, and mobile/portable communications devices operating in Bands 3 and 7.

Functional Block Diagram

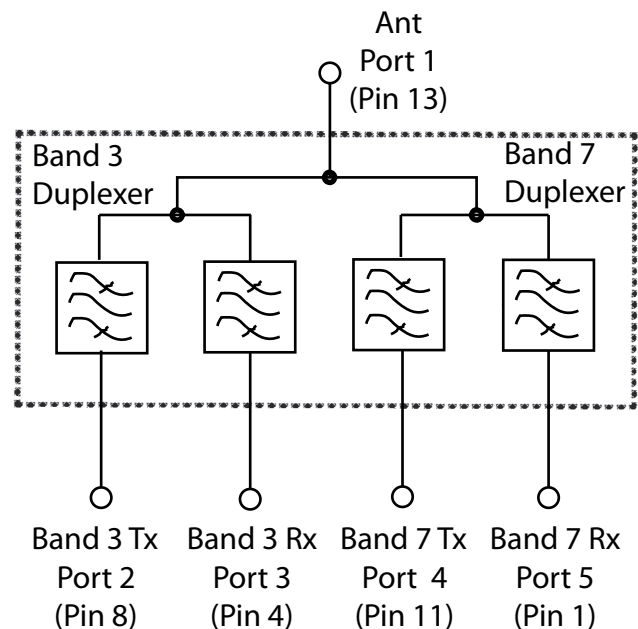

Ordering Information

Part Number	Number of Devices	Container
ACFM-7037-BLK	100	Tape strip or gel-pack
ACFM-7037-TR1	3000	178 mm (7-inch) reel

Package Dimensions and Marking Specification

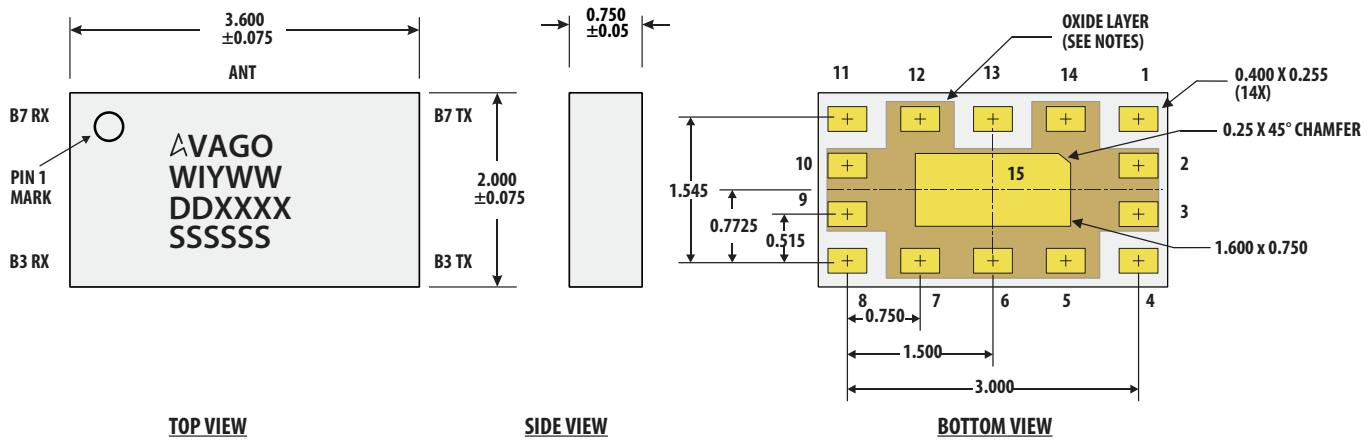

Notes:

1. Dimensions in millimeters
2. Tolerance, unless otherwise noted:
X.XX ± 0.05 mm
X.XXX ± 0.025 mm
3. Dimensions nominal unless otherwise noted
4. Angles 45° nominal
5. Contact areas are gold plated
6. Metal Gnd and I/O pads are solder mask defined by means of a thin (< 1µm) oxide layer

Package Marking Code:
AVAGO = Avago Technologies, Inc.
W = ACFM-7037
I = Assembly Information
Y = Year
WW = Work Week
DD = Date Code
XXXX = Assembly Lot
SSSSS = Production Information

Pin Description

Pin	Connection
1	Band 7 Rx
4	Band 3 Rx
8	Band 3 Tx
11	Band 7 Tx
13	Ant
2, 3, 5, 6, 7, 9, 10, 12, 14, 15	GND

For product information and a complete list of distributors, please go to our web site:

www.avagotech.com

Avago, Avago Technologies, and the A logo are trademarks of Avago Technologies in the United States and other countries. All other brand and product names may be trademarks of their respective companies.

Data subject to change. Copyright © 2015 Avago Technologies. All Rights Reserved.

AV02-4911EN – 2015-05-01

