

Chipsmall Limited consists of a professional team with an average of over 10 year of expertise in the distribution of electronic components. Based in Hongkong, we have already established firm and mutual-benefit business relationships with customers from,Europe,America and south Asia,supplying obsolete and hard-to-find components to meet their specific needs.

With the principle of “Quality Parts,Customers Priority,Honest Operation,and Considerate Service”,our business mainly focus on the distribution of electronic components. Line cards we deal with include Microchip,ALPS,ROHM,Xilinx,Pulse,ON,Everlight and Freescale. Main products comprise IC,Modules,Potentiometer,IC Socket,Relay,Connector.Our parts cover such applications as commercial,industrial, and automotives areas.

We are looking forward to setting up business relationship with you and hope to provide you with the best service and solution. Let us make a better world for our industry!



Contact us

Tel: +86-755-8981 8866 Fax: +86-755-8427 6832

Email & Skype: info@chipsmall.com Web: www.chipsmall.com

Address: A1208, Overseas Decoration Building, #122 Zhenhua RD., Futian, Shenzhen, China



Active Cable Module - 16 bit Target Interface

Feature Connector - JP1

Control Line 4	1	2	Status Line 4
Control Line 3	3	4	Status Line 3
Control Line 2	5	6	Status Line 2
Control Line 1	7	8	Status Line 1
Trigger Out	9	10	-
Ready Out	11	12	-
Request Out	13	14	Grant
Trigger Ground	15	16	-

EPROM/FLASH Select - JP4

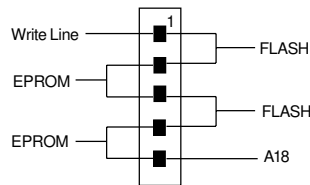

Reset Connector - JP2

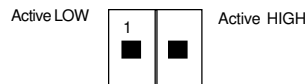

Additional Address Lines - JP5

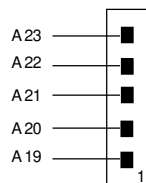

Target Cable Connector - JP3

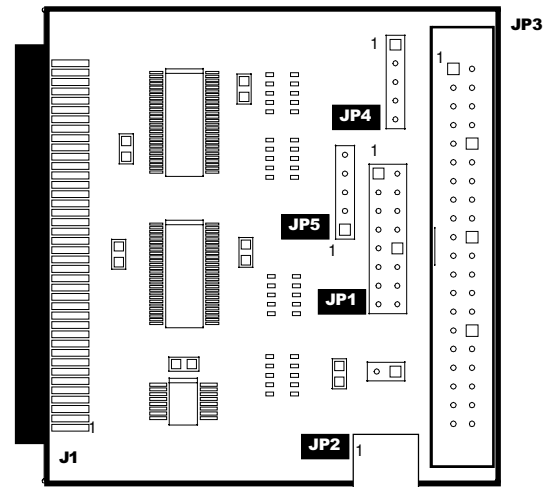

FlexROM III Connector - J1

WARNING:

Never remove or insert the ACM module when power is present. Always remove power from the emulator before changing the ACM module or Target Cable.

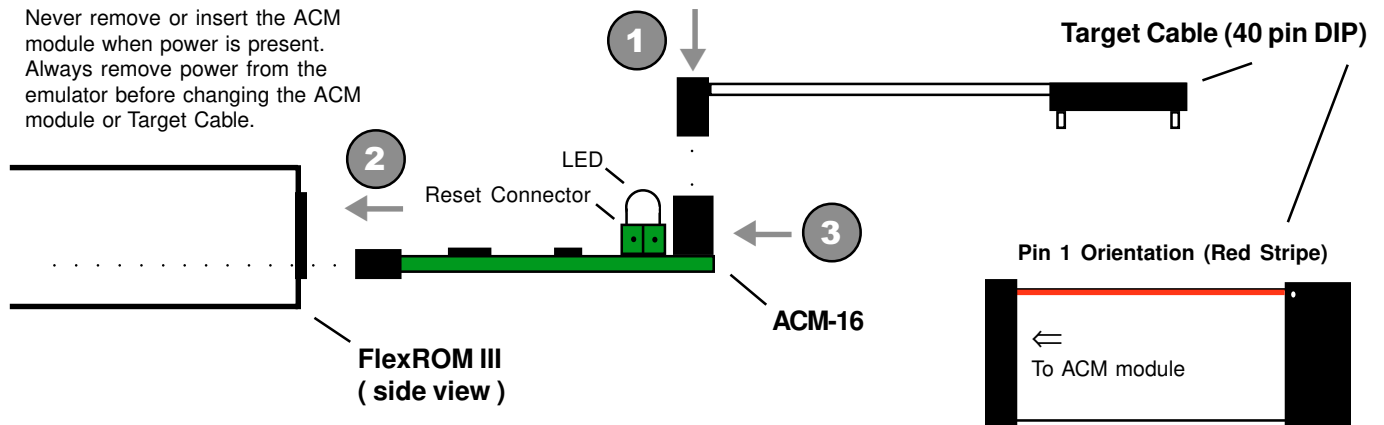

Insertion Instructions:

1. Connect the Target Cable to the ACM module.
2. Insert the ACM module into the open slot provided at the rear of the FlexROM III emulator.
3. Gently slide module into the unit until it stops. Then apply firm pressure until the ACM module seats completely.

(972) 272-9392, FAX: (972) 494-5814, sales@tech-tools.com, http://www.tech-tools.com