



Chipsmall Limited consists of a professional team with an average of over 10 year of expertise in the distribution of electronic components. Based in Hongkong, we have already established firm and mutual-benefit business relationships with customers from,Europe,America and south Asia,supplying obsolete and hard-to-find components to meet their specific needs.

With the principle of “Quality Parts,Customers Priority,Honest Operation,and Considerate Service”,our business mainly focus on the distribution of electronic components. Line cards we deal with include Microchip,ALPS,ROHM,Xilinx,Pulse,ON,Everlight and Freescale. Main products comprise IC,Modules,Potentiometer,IC Socket,Relay,Connector.Our parts cover such applications as commercial,industrial, and automotives areas.

We are looking forward to setting up business relationship with you and hope to provide you with the best service and solution. Let us make a better world for our industry!



Contact us

Tel: +86-755-8981 8866 Fax: +86-755-8427 6832

Email & Skype: info@chipsmall.com Web: www.chipsmall.com

Address: A1208, Overseas Decoration Building, #122 Zhenhua RD., Futian, Shenzhen, China



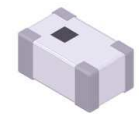

FEATURES:

- Effective for suppressing common mode noise at high frequency
- Excellent solderability
- Compact design

APPLICATIONS:

- Common mode noise suppression of differential signal lines in high speed and high-density digital equipments such as USB 2.0, IEEE1394, LVDS, Digital Camera, Scanner, etc.
- Digital audio and video equipments such as PDA, DSC, DVC, CD Player, DVD Player, etc.

ELECTRICAL SPECIFICATIONS:

Operating Temperature: -40°C to +85°C

Storage Temperature: -10°C to +40°C, 70% RH max

Parameters	Minimum	Typical	Maximum	Units	Notes
Center Frequency	-----	480.0	-----	MHz	
Common Mode Attenuation	10	-----	-----	dB	@130MHz ~ 1GHz
Differential Mode Insertion Loss	-----	-----	0.6	dB	@240MHz
DC Resistance	-----	-----	2.0	Ω	
Rated Current	-----	-----	200	mA	
Characteristic Impedance	90			Ω	

Unless otherwise specified, the standard atmospheric conditions for measurement/test as:

- Ambient Temperature: 20±15°C
- Relative Humidity: 65%±20%
- Air Pressure: 86 KPa to 106 KPa

Visual Examination

- Inspection Equipment: 20X magnifier

Electrical Test

- Impedance Analyzer: HP4991A.
- Network Analyzer: HP8719ES.

ELECTRICAL PROPERTIES

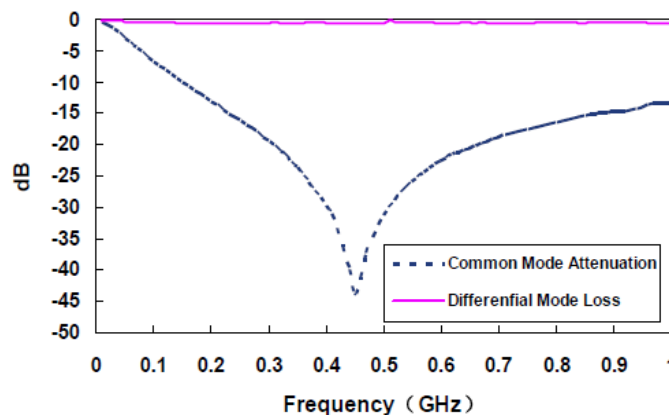

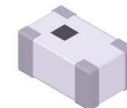

3.2 x 1.6 x 0.9mm

ACMF-31B



RoHS
Compliant

OUTLINE DRAWING:

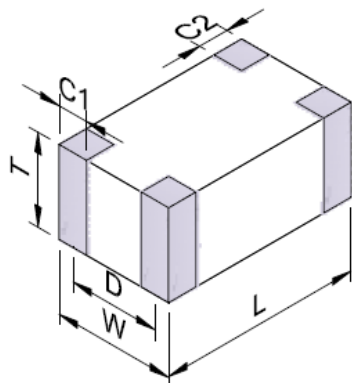

L	W	T	C1	C2	D
3.2±0.2	1.6±0.2	0.9±0.1	0.5±0.2	0.4±0.2	1.1±0.1

Recommended Land Pattern

Schematic

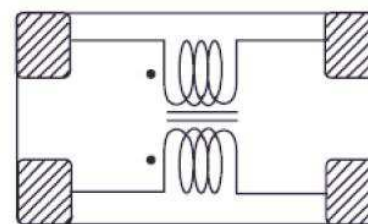
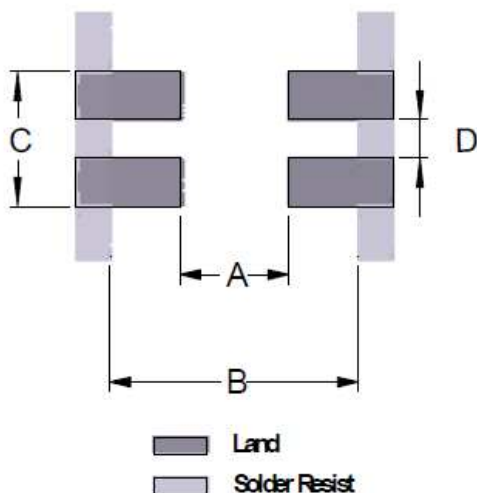

A	B	C	D
1.6	3.7	1.6	0.4

Dimension: mm

REFLOW PROFILE:

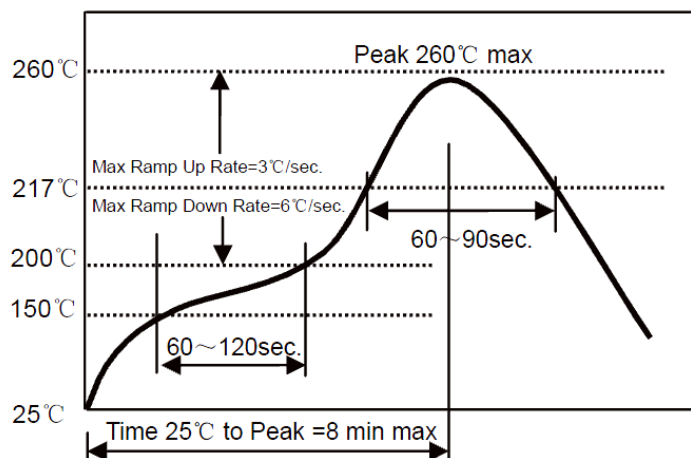

- Preheat condition: 150 ~200°C/60~120sec.
- Allowed time above 217 °C: 60~90sec.
- Max temp: 260 °C
- Max time at max temp: 10sec.
- Solder paste: Sn/3.0Ag/0.5Cu
- Allowed Reflow time: 2x max



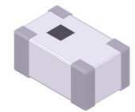

3.2 x 1.6 x 0.9mm

ACMF-31B



RoHS
Compliant

TAPE & REEL:

T= tape and reel (3,000pcs/reel)

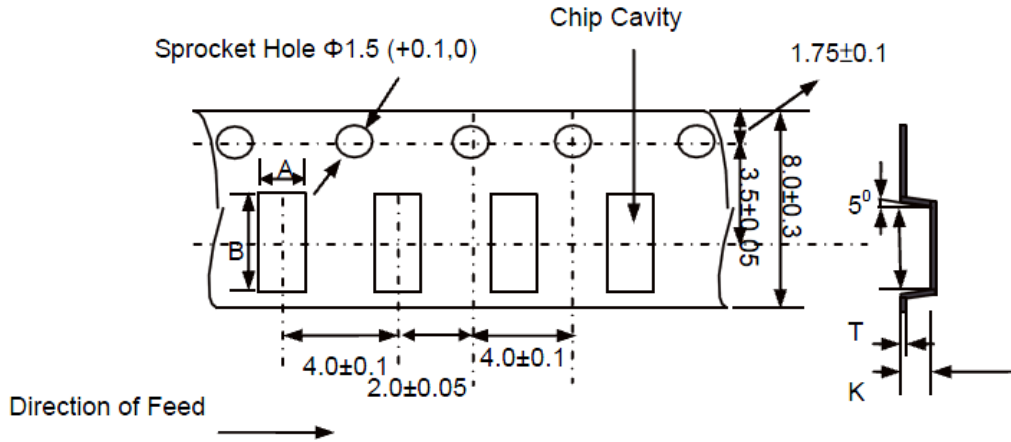

A	B	K max	T max
1.85 ± 0.10	3.50 ± 0.10	1.14	0.27

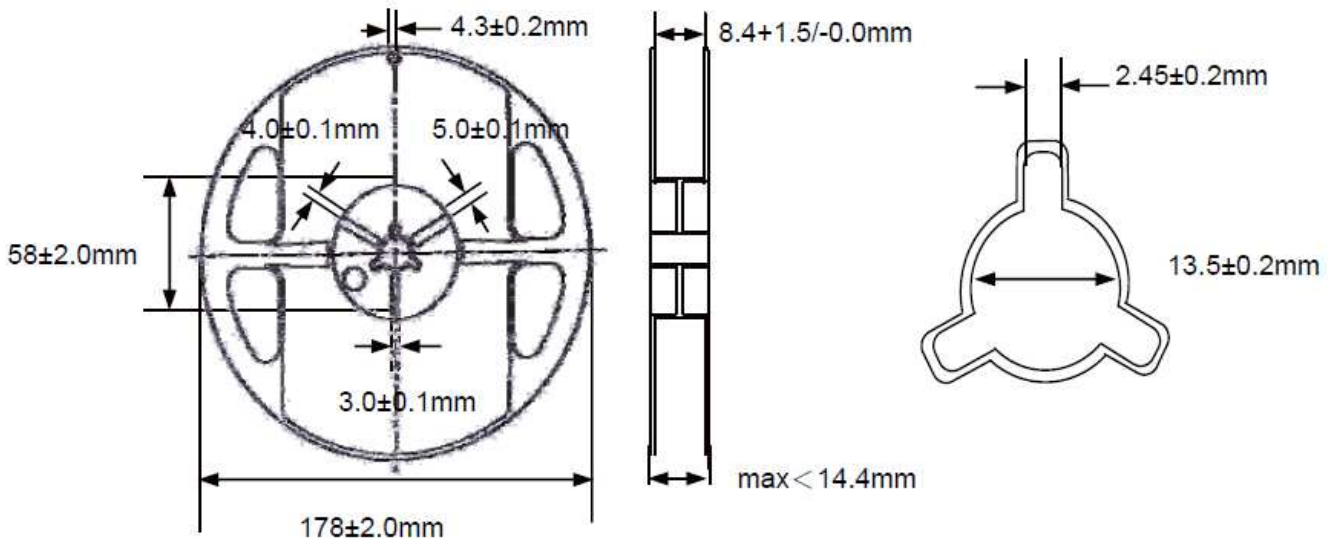

Dimension: mm

ATTENTION: Abracon Corporation's products are COTS – Commercial-Off-The-Shelf products; suitable for Commercial, Industrial and, where designated, Automotive Applications. Abracon's products are not specifically designed for Military, Aviation, Aerospace, Life-dependant Medical applications or any application requiring high reliability where component failure could result in loss of life and/or property. For applications requiring high reliability and/or presenting an extreme operating environment, written consent and authorization from Abracon Corporation is required. Please contact Abracon Corporation for more information.

