



Chipsmall Limited consists of a professional team with an average of over 10 year of expertise in the distribution of electronic components. Based in Hongkong, we have already established firm and mutual-benefit business relationships with customers from,Europe,America and south Asia,supplying obsolete and hard-to-find components to meet their specific needs.

With the principle of “Quality Parts,Customers Priority,Honest Operation,and Considerate Service”,our business mainly focus on the distribution of electronic components. Line cards we deal with include Microchip,ALPS,ROHM,Xilinx,Pulse,ON,Everlight and Freescale. Main products comprise IC,Modules,Potentiometer,IC Socket,Relay,Connector.Our parts cover such applications as commercial,industrial, and automotives areas.

We are looking forward to setting up business relationship with you and hope to provide you with the best service and solution. Let us make a better world for our industry!



Contact us

Tel: +86-755-8981 8866 Fax: +86-755-8427 6832

Email & Skype: info@chipsmall.com Web: www.chipsmall.com

Address: A1208, Overseas Decoration Building, #122 Zhenhua RD., Futian, Shenzhen, China



40V/3.0A CV/CC Buck Converter Featuring USB-PD

FEATURES

- USB-PD Support
- Passes USB-IF Certification: Test ID 1010060
- 40V Input Voltage Surge
- 4.5V-36V Operational Input Voltage
- 5.1V/9.1V/12.1V Output with +/-1% Accuracy
- Up to 3.0A Output current
- Constant Current Regulation Limit
- Hiccup Mode Protection at Output Short
- >90% Efficiency at Full Load
- 0.5mA Low Standby Input Current
- 5.1V/9.1V/12.1V Output Over-Voltage Protection
- Cord Voltage Compensation
- Meet EN55022 Class B Radiated EMI Standard
- SOP-8EP Package

APPLICATIONS

- Car Charger
- Cigarette Lighter Adaptor (CLA)
- Rechargeable Portable Device
- CV/CC regulation DC/DC converter

GENERAL DESCRIPTION

ACT4527 is a wide input voltage, high efficiency step-down DC/DC converter that operates in either CV (Constant Output Voltage) mode or CC (Constant Output Current) mode. ACT4527 has an interface for USB-PD control via a tri-state digital pin. Vout is 5.1V if this pin is floating, Vout is 9.1V when this pin voltage is less than 0.8V and Vout is 12.1V while this pin voltage is more than 2.0V.

ACT4527 has accurate output current limits under constant current regulation. It provides up to 3.0A output current at 125kHz switching frequency. ACT4527 utilizes adaptive drive technique to achieve good EMI performance while main >90% efficiency at full load for mini size CLA designs. It also has output short circuit protection with hiccup mode. The average output current is reduced to below 6mA when output is shorted to ground. Other features include output over voltage protection and thermal shutdown.

This device is available in a SOP-8EP package and require very few external components for operation.

Typical Application Circuit

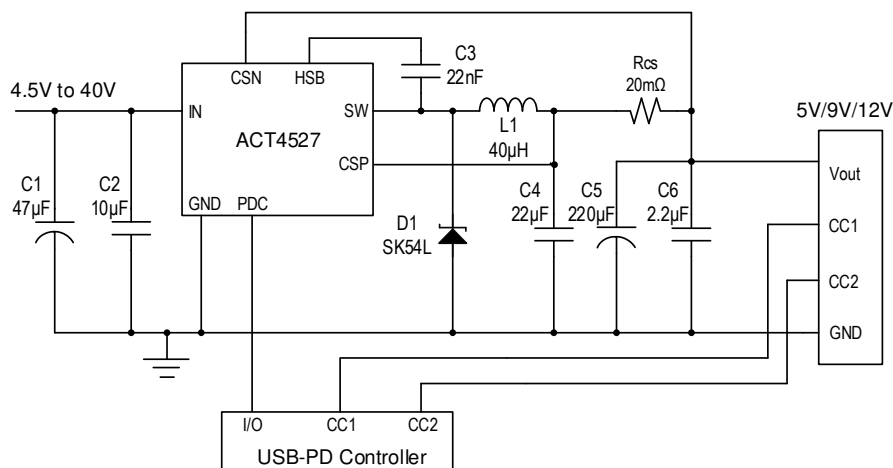

V/I Profile

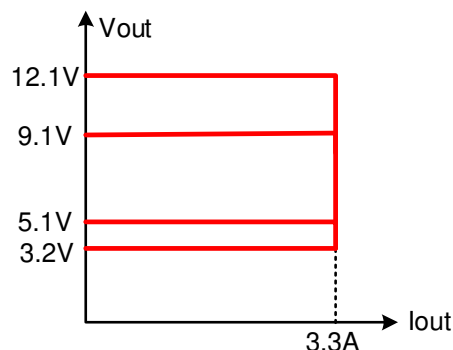

* Patent Pending

ORDERING INFORMATION

PART NUMBER	OPERATION TEMPERATURE RANGE	PACKAGE	FREQUENCY	PACKING
ACT4527YH-T	-40°C to 85°C	SOP-8EP	125kHz	TAPE & REEL

PIN CONFIGURATION

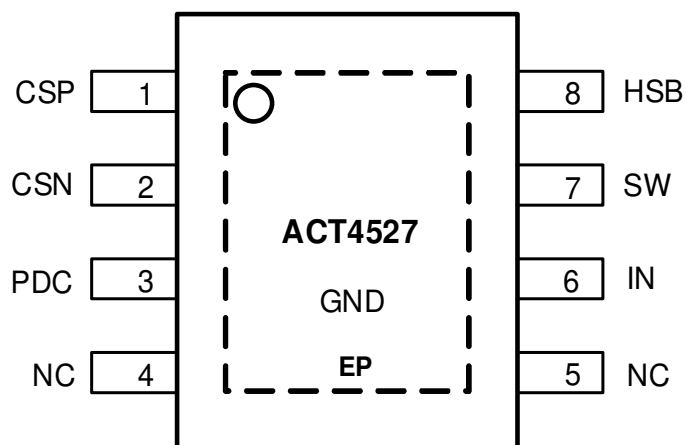

SOP-8EP

Top View

PIN DESCRIPTIONS

PIN	NAME	DESCRIPTION
1	CSP	Voltage Feedback Input. Connect to node of the inductor and output capacitor. CSP and CSN Kevin sense is recommended.
2	CSN	Negative input terminal of output current sense. Connect to the negative terminal of current sense resistor.
3	PDC	USB-PD Control Pin. floating: 5.1V, pulled high: 12.1V, pulled low: 9.1V. Do not drive this pin higher than 5V.
4	NC	No Connection Pin. Must leave this pin floating.
5	NC	No Connection Pin. Must leave this pin floating.
6	IN	Power Supply Input. Bypass this pin with a 10 μ F ceramic capacitor to GND, placed as close to the IC as possible.
7	SW	Power Switching Output to External Inductor.
8	HSB	High Side Bias Pin. This provides power to the internal high-side MOSFET gate driver. Connect a 22nF capacitor from HSB pin to SW pin.
9	GND	Ground and Heat Dissipation Pad. Connect this exposed pad to large ground copper area with copper and vias.

ABSOLUTE MAXIMUM RATINGS^①

PARAMETER	VALUE	UNIT
IN to GND	-0.3 to 40	V
SW to GND	-1 to $V_{IN} + 1$	V
HSB to GND	$V_{SW} - 0.3$ to $V_{SW} + 7$	V
CSP, CSN to GND	-0.3 to +15	V
PDC to GND	-0.3 to +6	V
All other pins to GND	-0.3 to +6	V
Junction to Ambient Thermal Resistance	46	$^{\circ}$ C/W
Operating Junction Temperature	-40 to 150	$^{\circ}$ C
Storage Junction Temperature	-55 to 150	$^{\circ}$ C
Lead Temperature (Soldering 10 sec.)	300	$^{\circ}$ C

①: Do not exceed these limits to prevent damage to the device. Exposure to absolute maximum rating conditions for long periods may affect device reliability.

ELECTRICAL CHARACTERISTICS

 ($V_{IN} = 12V$, $T_A = 25^\circ C$, unless otherwise specified.)

Parameter	Symbol	Condition	Min	Typ	Max	Unit
Input Over Voltage Protection	VIN_OVP	Rising	40	42	44	V
Input Over Voltage Hysteresis				4		V
Input Over Voltage Response Time	T_VIN_OVP	VIN step from 30V to 45V		250		ns
Input Under Voltage Lockout (UVLO)	VIN	Rising		4.5		V
Input UVLO Hysteresis				200		mV
Input Voltage Power Good Deglitch Time		No OVP		40		ms
Input Voltage Power Good Deglitch Time		No UVP		10		us
Input Standby Current		Vin=12V, Vout=5.1V, Iload=0		500		uA
Output Voltage Regulation	CSP		5.05 9.0 11.95	5.1 9.1 12.1	5.15 9.2 12.25	V
Output Over Voltage Protection (OVP)		Output rising		5.7 10.1 13.5		V
Output Over Voltage Deglitch Time				1.0		us
Output Voltage Load Compensation		66 mV between CSP and CSN	-15%	200	+15%	mV
Output Under Voltage Protection (UVP)	VOUT	VOUT falling	-10%	3.2	10%	V
UVP Hysteresis	VOUT	VOUT rising		0.2		V
UVP Deglitch Time	VOUT			10		us
UVP Blanking Time at Startup				3.5		ms
Output Constant Current Limit		Rcs=20mΩ	3.1	3.3	3.5	A
Hiccup Waiting Time				4.13		S
Top FET Cycle by Cycle Current Limit			4.5	5.8		A
Top FET Rdson				70		mΩ
Bottom FET Rdson				4.7		Ω

ELECTRICAL CHARACTERISTICS

 (V_{IN} = 12V, T_A = 25°C, unless otherwise specified.)

Parameter	Symbol	Condition	Min	Typ	Max	Units
Maximum Duty Cycle			99			%
Switching Frequency			-10%	125	+10%	kHz
Soft-start Time				2.0		ms
Out Voltage Ripples		C _{out} =220uF/22uF ceramic		80		mV
VO _{UT} Discharge Current		For high to lower voltage transitions		60		mA
Voltage transition time		12V-5V			100	ms
Voltage transition time		5V-12V			100	ms
Line Transient Response		Input 12V-40V-12V with 1V/us slew rate, V _{out} =5V, I _{load} =0A and 2.4A	4.75		5.25	V
Load Transient Response	V _{out} =5V	80mA-1.0A-80mA load with 0.1A/us slew rate	4.9	5.15	5.4	V
	V _{out} =9V	80mA-1.0A-80mA load with	8.7	9.1	9.5	V
	V _{out} =12V	80mA-1.0A-80mA load with	11.6	12.1	12.6	V
Thermal Shut Down				160		°C
Thermal Shut Down Hysteresis				30		°C
PDC Floating				1.5		V
PDC High			2.0			V
PDC Low					0.8	V
PDC Maximum Voltage					5.5	V
PDC Drive Current				10		uA

FUNCTIONAL BLOCK DIAGRAM

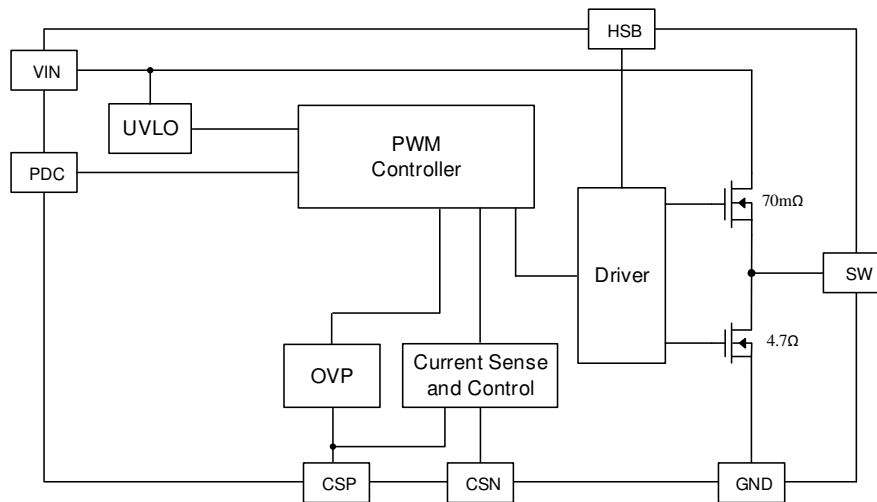

FUNCTIONAL DESCRIPTION

Output Current Sensing and Regulation

Sense resistor is connected to CSP and CSN. The sensed differential voltage is compared with interval reference to regulate current. CC loop and CV loop are in parallel. The current loop response is allowed to have slower response compared to voltage loop. However, during current transient response, the inductor current overshoot/undershoot should be controlled within +/-25% to avoid inductor saturation.

Cycle-by-Cycle Current Control

The conventional cycle-by-cycle peak current mode is implemented with high-side FET current sense.

Input Over Voltage Protection

The converter is disabled if the input voltage is above 42V (+/-2V). Device resumes operation automatically 40ms after OVP is cleared.

Output Over Voltage Protection

Device stops switching when output over-voltage is sensed, and resumes operation automatically when output voltage drops to OVP- hysteresis.

Output Over Voltage Discharge

Discharge circuit starts to discharge output through CSP pins when output over voltage is detected. Discharge circuit brings 12V down to 5V in less than 100ms.

Output Under-Voltage Protection / Hiccup Mode

There is a under voltage protection (UVP) threshold. If the UVP threshold is hit for 10us, an over current or short circuit is assumed, and the converter goes into hiccup mode by disabling the converter and restarts after hiccup waiting period.

Cord Compensation

In some applications, the output voltage is increased with output current to compensate the potential voltage drop across output cable. The compensation is based on the high side feedback resistance.

The compensation voltage is derived as:

$$\Delta V_{out} = (V_{CSP} - V_{CSN}) * K$$

Where K=3.03

This voltage difference could be added on the reference or turning the $(V_{CSP} - V_{CSN})$ voltage into a sink current at FB pin to pull Vout higher than programmed voltage.

The cord compensation loop should be very slow to avoid potential disturbance to the voltage loop. The voltage loop should be sufficiently stable on various cord compensation setting.

Thermal Shutdown

If the T_J increases beyond 160°C, ACT4527 goes into HZ mode and the timer is preserved until T_J drops by 30°C.

APPLICATIONS INFORMATION

Inductor Selection

The inductor maintains a continuous current to the output load. This inductor current has a ripple that is dependent on the inductance value.

Higher inductance reduces the peak-to-peak ripple current. The trade off for high inductance value is the increase in inductor core size and series resistance, and the reduction in current handling capability. In general, select an inductance value L based on ripple current requirement:

$$L = \frac{V_{OUT} \times (V_{IN} - V_{OUT})}{V_{IN} f_{SW} I_{LOADMAX} K_{RIPPLE}} \quad (1)$$

Where V_{IN} is the input voltage, V_{OUT} is the output voltage, f_{SW} is the switching frequency, $I_{LOADMAX}$ is the maximum load current, and K_{RIPPLE} is the ripple factor. Typically, choose $K_{RIPPLE} = 30\%$ to correspond to the peak-to-peak ripple current being 30% of the maximum load current.

With a selected inductor value the peak-to-peak inductor current is estimated as:

$$I_{LPK-PK} = \frac{V_{OUT} \times (V_{IN} - V_{OUT})}{L \times V_{IN} \times f_{SW}} \quad (2)$$

The peak inductor current is estimated as:

$$I_{LPK} = I_{LOADMAX} + \frac{1}{2} I_{LPK-PK} \quad (3)$$

The selected inductor should not saturate at I_{LPK} . The maximum output current is calculated as:

$$I_{OUTMAX} = I_{LIM} - \frac{1}{2} I_{LPK-PK} \quad (4)$$

I_{LIM} is the internal current limit.

Input Capacitor

The input capacitor needs to be carefully selected to maintain sufficiently low ripple at the supply input of the converter. A low ESR capacitor is highly recommended. Since large current flows in and out of this capacitor during switching, its ESR also affects efficiency.

The input capacitance needs to be higher than $10\mu\text{F}$. The best choice is the ceramic type. However, low ESR tantalum or electrolytic types may also be used provided that the RMS ripple current rating is higher than 50% of the output current. The input capacitor should be placed close to the IN and GND pins of the IC, with the shortest traces possible. In the case of tantalum or electrolytic types, a ceramic capacitor is

recommended to parallel with tantalum or electrolytic capacitor, which should be placed right next to the IC.

Output Capacitor

The output capacitor also needs to have low ESR to keep low output voltage ripple. The output ripple voltage is:

$$V_{RIPPLE} = I_{OUTMAX} K_{RIPPLE} R_{ESR} + \frac{(V_{IN} - V_{OUT}) \times V_{OUT}}{8 \times f_{SW}^2 L C_{OUT} \times V_{IN}} \quad (5)$$

Where I_{OUTMAX} is the maximum output current, K_{RIPPLE} is the ripple factor, R_{ESR} is the ESR of the output capacitor, f_{SW} is the switching frequency, L is the inductor value, and C_{OUT} is the output capacitance. In the case of ceramic output capacitors, R_{ESR} is very small and does not contribute to the ripple. Therefore, a lower capacitance value can be used for ceramic type. In the case of tantalum or electrolytic capacitors, the ripple is dominated by R_{ESR} multiplied by the ripple current. In that case, the output capacitor is chosen to have sufficiently low ESR.

For ceramic output capacitor, typically choose a capacitance of about $22\mu\text{F}$. For tantalum or electrolytic capacitors, choose a capacitor with less than $50\text{m}\Omega$ ESR. If an $330\mu\text{F}$ or $470\mu\text{F}$ electrolytic capacitor is used, where ripple is dominantly caused by ESR, an $2.2\mu\text{F}$ ceramic is recommended.

Rectifier Schottky Diode

Use a Schottky diode as the rectifier to conduct current when the High-Side Power Switch is off. The Schottky diode must have current rating higher than the maximum output current and a reverse voltage rating higher than the maximum input voltage. Further more, the low forward voltage Schottky is preferable for high efficiency and smoothly operation.

APPLICATIONS INFORMATION

Current Sense Resistor

The traces leading to and from the sense resistor can be significant error sources. With small value sense resistors, trace resistance shared with the load can cause significant errors. It is recommended to connect the sense resistor pads directly to the CSP and CSN pins using “Kelvin” or “4-wire” connection techniques as shown below.

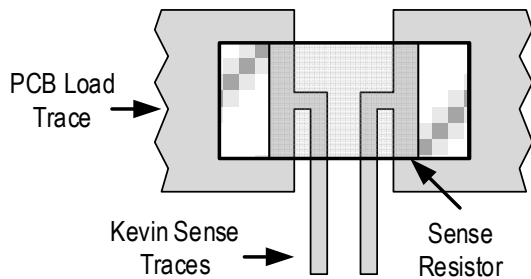

Current Limit Setting

If output current hits current limit, output voltage drops to keep the current to a constant value.

The following equation calculates the constant current limit.

$$I_{Limit} (A) = \frac{66mV}{R_{cs} (m\Omega)} \quad (6)$$

Where R_{cs} is current sense resistor.

APPLICATIONS INFORMATION

PCB Layout Guidance

When laying out the printed circuit board, the following checklist should be used to ensure proper operation of the IC.

- 1) Arrange the power components to reduce the AC loop size consisting of C_{IN} , V_{IN} pin, SW pin and the Schottky diode.
- 2) The high power loss components, e.g. the controller, Schottky diode, and the inductor should be placed carefully to make the thermal spread evenly on the board.
- 3) Place input decoupling ceramic capacitor C_{IN} as close to V_{IN} pin as possible. C_{IN} should be connected to power GND with several vias or short and wide copper trace.
- 4) Schottky anode pad and IC exposed pad should be placed close to ground clips in CLA applications.
- 5) Use “Kelvin” or “4-wire” connection techniques from the sense resistor pads directly to the CSP and CSN pins. The CSP and CSN traces should be in parallel to avoid interference.
- 6) Place multiple vias between top and bottom GND planes for best heat dissipation and noise immunity.
- 7) Use short traces connecting HSB- C_{HSB} -SW loop.
- 8) SW pad is noise node switching from V_{IN} to GND. It should be isolated away from the rest of circuit for good EMI and low noise operation.

Example PCB Layout

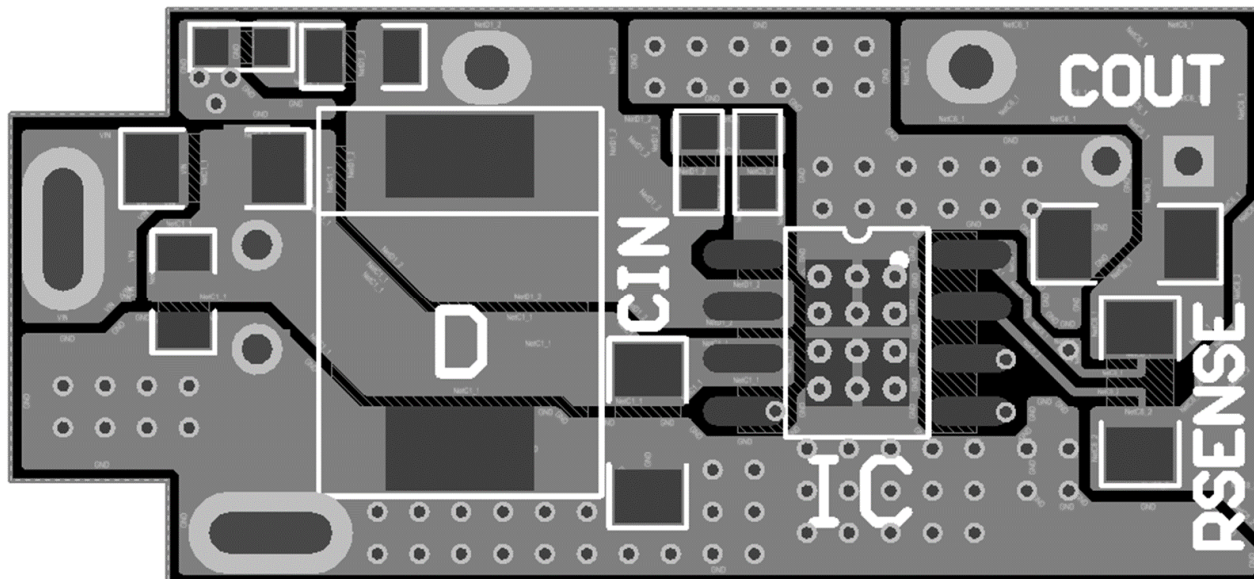

Typical Application Circuit

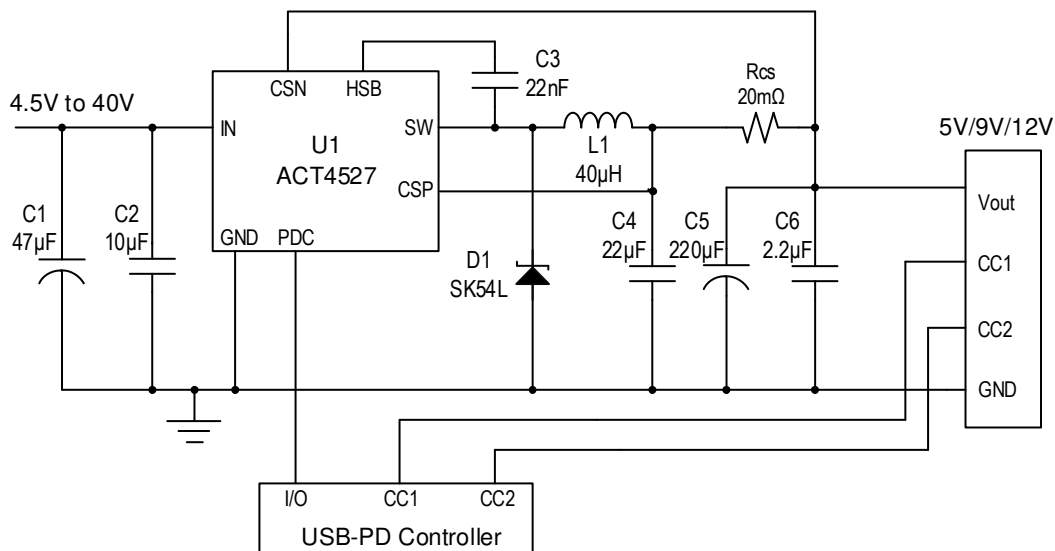

BOM List for 3.0A USB PD Car Charger

ITEM	REFERENCE	DESCRIPTION	MANUFACTURER	QTY
1	U1	IC, ACT4527, SOP-8EP	Active-Semi	1
2	C1	Capacitor, Electrolytic, 47µF/35V	Murata, TDK	1
3	C2	Capacitor, Ceramic, 10µF/25V, 1206, SMD	Murata, TDK	1
4	C3	Capacitor, Ceramic, 22nF/25V, 0603, SMD	Murata, TDK	1
5	C4	Capacitor, Ceramic, 22µF/16V, 1206, SMD	Murata, TDK	1
6	C5	Capacitor, Electrolytic, 220µF/16V	Murata, TDK	1
7	C6	Capacitor, Ceramic, 2.2µF/16V, 0805, SMD	Murata, TDK	1
8	L1	Inductor, 40µH, 4.0A, 20%		1
9	D1	Diode, Schottky, 40V/5A, SK54L	Panjit	1
10	Rcs	Chip Resistor, 20mΩ, 1206, 1%	Murata, TDK	1

TYPICAL PERFORMANCE CHARACTERISTICS

(Schematic as show in typical application circuit, Ta = 25°C, unless otherwise specified)

Efficiency vs. Load current (5V Vout)

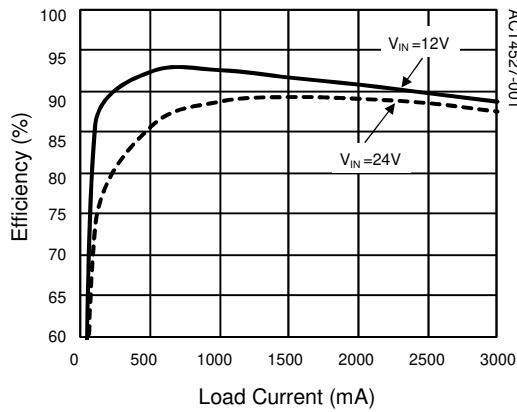

Efficiency vs. Load current (9V Vout)

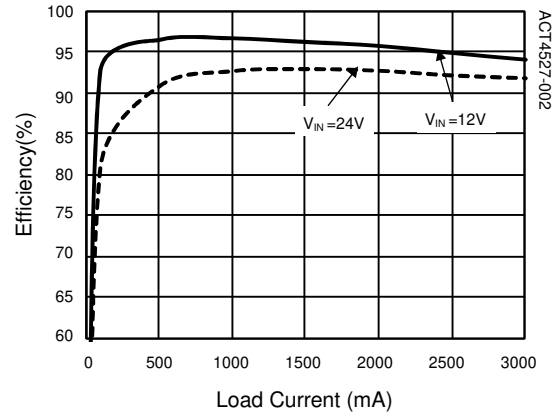

Efficiency vs. Load current (12V Vout)

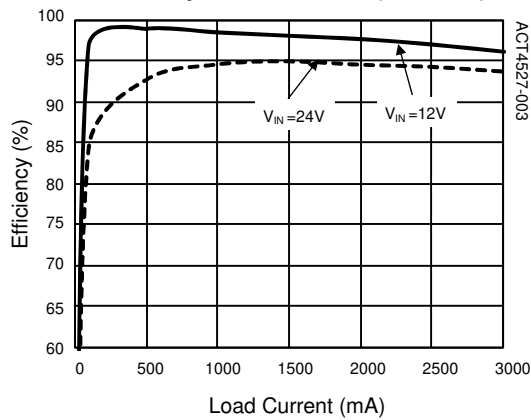

Output CC/CV Curve (5V Vout)

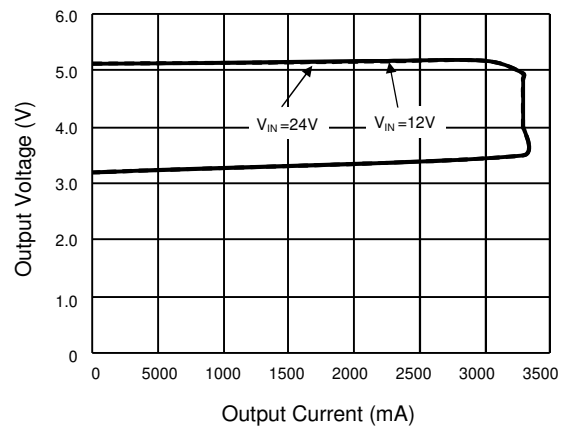

Output CC/CV Curve (9V Vout)

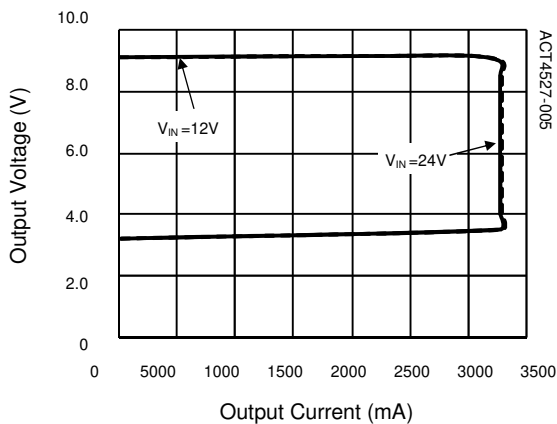

Output CC/CV Curve (12V Vout)

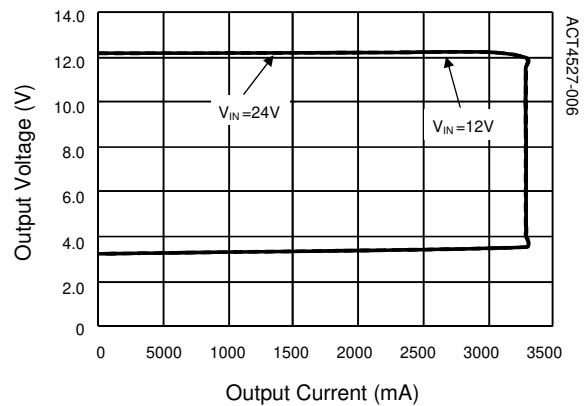

TYPICAL PERFORMANCE CHARACTERISTICS

(Schematic as show in typical application circuit, Ta = 25°C, unless otherwise specified)

Output Over Voltage (5V Vout)

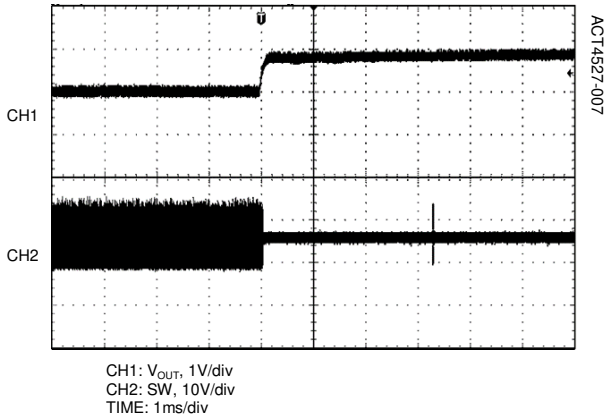

Start up into CC Mode

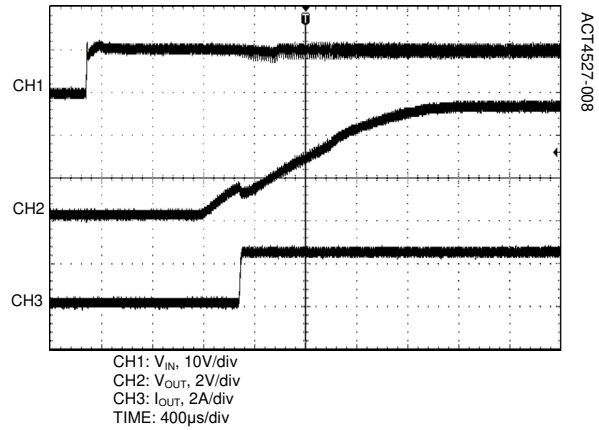

Load Transient (80mA-1A-80mA)
 $V_{in}=12V$, $V_{out}=5V$

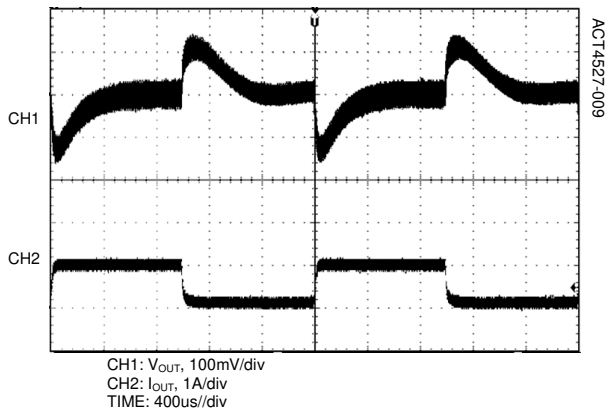

Load Transient (1A-2.4A-1A)
 $V_{in}=12V$, $V_{out}=5V$

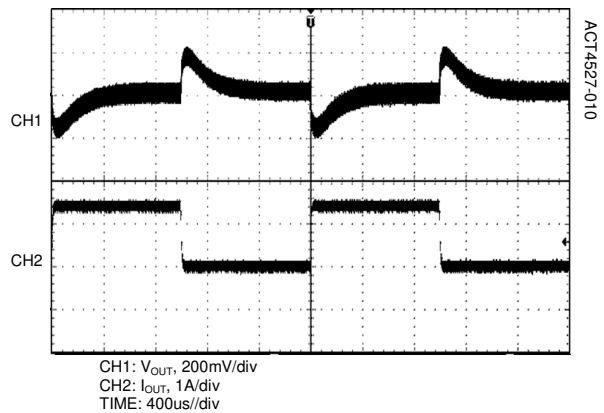

Load Transient (80mA-1A-80mA)
 $V_{in}=12.6V$, $V_{out}=12V$

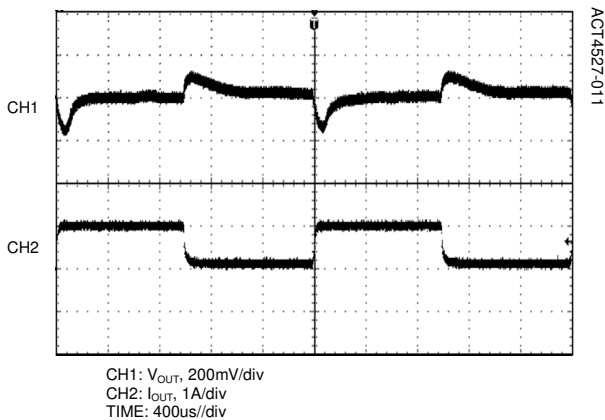

Load Transient (1A-2.4A-1A)
 $V_{in}=12.6V$, $V_{out}=12V$

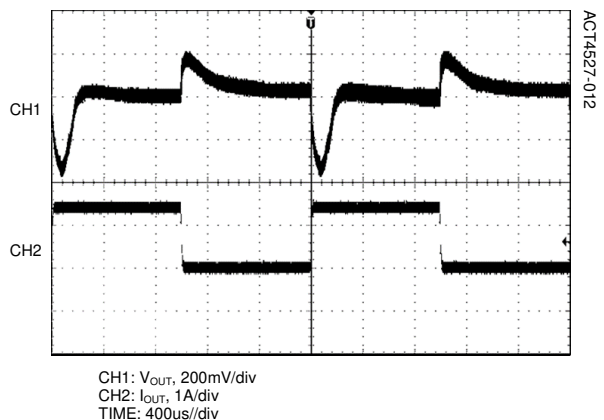

TYPICAL PERFORMANCE CHARACTERISTICS

(Schematic as show in typical application circuit, Ta = 25°C, unless otherwise specified)

Voltage Transient (5V-9V)

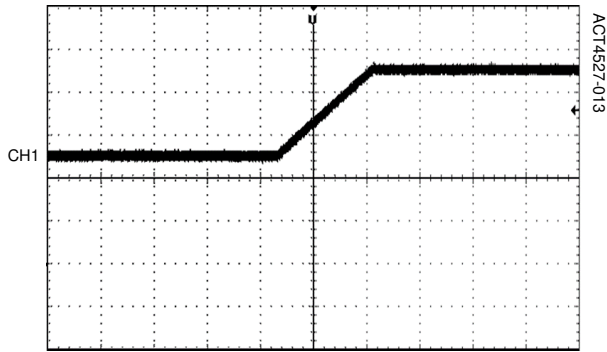

CH1: V_{OUT}, 2V/div
TIME: 10ms/div

Voltage Transient (9V-5V)

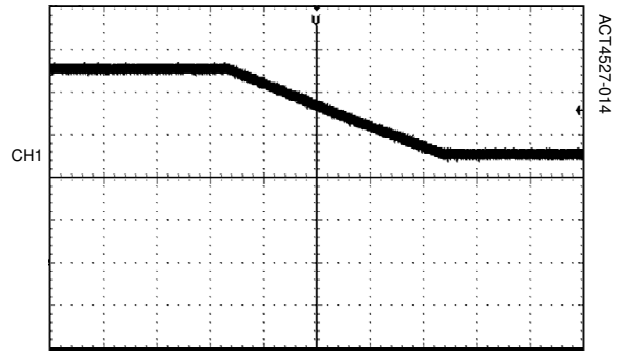

CH1: V_{OUT}, 2V/div
TIME: 10ms/div

Voltage Transient (5V-12V)

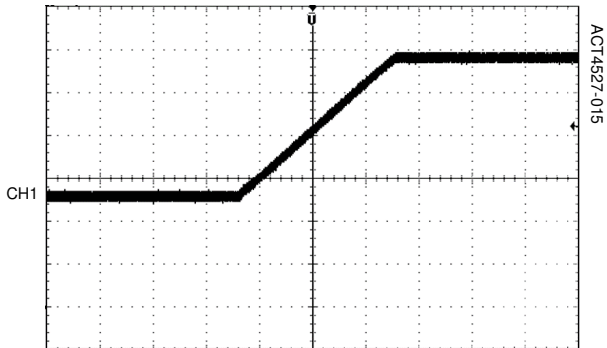

CH1: V_{OUT}, 2V/div
TIME: 10ms/div

Voltage Transient (12V-5V)

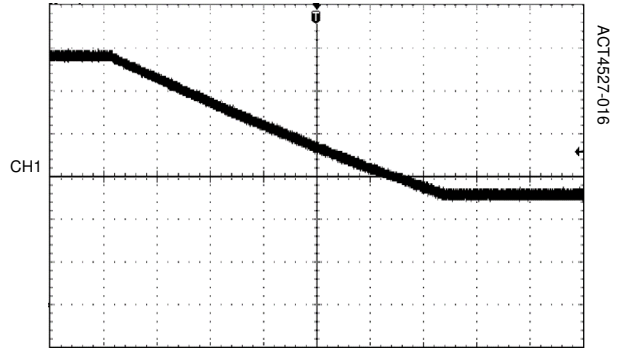

CH1: V_{OUT}, 2V/div
TIME: 10ms/div

PACKAGE OUTLINE

SOP-8EP PACKAGE OUTLINE AND DIMENSIONS

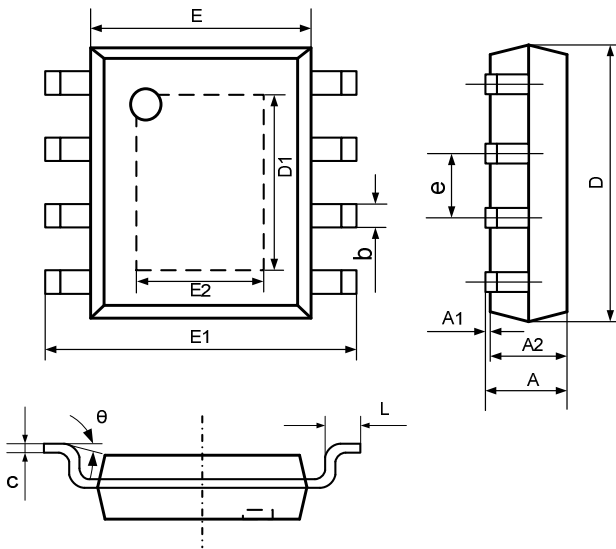

SYMBOL	DIMENSION IN MILLIMETERS		DIMENSION IN INCHES	
	MIN	MAX	MIN	MAX
A	1.350	1.727	0.053	0.068
A1	0.000	0.152	0.000	0.006
A2	1.245	1.550	0.049	0.061
b	0.330	0.510	0.013	0.020
c	0.170	0.250	0.007	0.010
D	4.700	5.100	0.185	0.200
D1	3.202	3.402	0.126	0.134
E	3.734	4.000	0.147	0.157
E1	5.800	6.200	0.228	0.244
E2	2.313	2.513	0.091	0.099
e	1.270 TYP		0.050 TYP	
L	0.400	1.270	0.016	0.050
θ	0°	8°	0°	8°

Active-Semi, Inc. reserves the right to modify the circuitry or specifications without notice. Users should evaluate each product to make sure that it is suitable for their applications. Active-Semi products are not intended or authorized for use as critical components in life-support devices or systems. Active-Semi, Inc. does not assume any liability arising out of the use of any product or circuit described in this datasheet, nor does it convey any patent license.

Active-Semi and its logo are trademarks of Active-Semi, Inc. For more information on this and other products, contact sales@active-semi.com or visit <http://www.active-semi.com>.

active-semi[®] is a registered trademark of Active-Semi.