



Chipsmall Limited consists of a professional team with an average of over 10 year of expertise in the distribution of electronic components. Based in Hongkong, we have already established firm and mutual-benefit business relationships with customers from,Europe,America and south Asia,supplying obsolete and hard-to-find components to meet their specific needs.

With the principle of "Quality Parts,Customers Priority,Honest Operation,and Considerate Service",our business mainly focus on the distribution of electronic components. Line cards we deal with include Microchip,ALPS,ROHM,Xilinx,Pulse,ON,Everlight and Freescale. Main products comprise IC,Modules,Potentiometer,IC Socket,Relay,Connector.Our parts cover such applications as commercial,industrial, and automotives areas.

We are looking forward to setting up business relationship with you and hope to provide you with the best service and solution. Let us make a better world for our industry!



Contact us

Tel: +86-755-8981 8866 Fax: +86-755-8427 6832

Email & Skype: info@chipsmall.com Web: www.chipsmall.com

Address: A1208, Overseas Decoration Building, #122 Zhenhua RD., Futian, Shenzhen, China



ADI AD-FMCJESDADC1-EBZ Boards & Xilinx Reference Design

Introduction

The [AD-FMCJESDADC1-EBZ](#) is a high speed data acquisition (4 ADC channels at 250MSPS), in an FMC form factor, which has two high speed JESD-204B Analog to Digital converters ([AD9250](#)) on it.

This board is similar to the [4DSP FMC-176](#), which in addition to the [AD9250](#), has two [AD9129](#) DACs. This reference design works for either of the boards, for details see [fmc-176_information](#) section.

Also included in this wiki is a dual AD-FMCJESDADC1-EBZ on [VC707](#) reference design, for details see [Dual AD-FMCJESDADC1-EBZ](#) section.

The [AD9250](#) is a dual, 14-bit ADC with sampling speeds of up to 250 MSPS. It features a multistage, differential pipelined architecture with integrated output error correction logic. It supports wide bandwidth inputs for a variety of user-selectable input ranges. The [AD9250](#) features JESD204B high speed serial interface.

The boards also feature the [AD9517-1](#) for multi-output clock distribution with sub-picosecond jitter performance, along with an on-chip PLL and VCO. The devices may be clocked by either an internal clock source (optionally locked to an external reference) or an externally supplied sample clock.





It also features an external trigger input for customized sampling control. The card is mechanically and electrically compliant to the FMC standard (ANSI/VITA 57.1).

The reference design includes the device data capture via the JESD204B serial interface and the SPI interface. The samples are written to the external DDR-DRAM. It allows programming the device and monitoring it's internal registers via SPI.

Supported Devices

- [AD-FMCJESDADC1-EBZ \(ADI\)](#)

Supported Carriers

-  ML605
-  KC705
-  VC707
-  ZC706

Quick Start Guide

The reference design zip file contains a bit file combined with a SDK elf file for a quick demonstration of the programming, RF conversion and data capture. All you need is the hardware and a PC running a UART terminal and the programmer (IMPACT).

Required Hardware

- ML605, KC705 or VC707 board
- AD-FMCJESDADC1-EBZ
- Signal generators (for ADC inputs)

Required Software

- Xilinx ISE (Programmer (IMPACT) is sufficient for the demo and is available on Webpack).
- A UART terminal (Tera Term/Hyperterminal), Baud rate 57600.

Bit file

- Download the gzip file and extract the **sw/cf_fmc176_kc705.bit** file.

Running Demo (SDK) Program

To begin make the following connections (see image below):

- Connect the AD-FMCJESDADC1-EBZ board to the FMC-HPC connector of ML605/KC705 (FMC1-HPC if VC707) board.
- Connect power to ML605/KC705/VC707.
- Connect two USB cables from the PC to the *JTAG* and *UART* USB connectors on ML605/KC705/VC707.
- Connect signal generators to the A3, A2, A1 and/or A0 connectors.

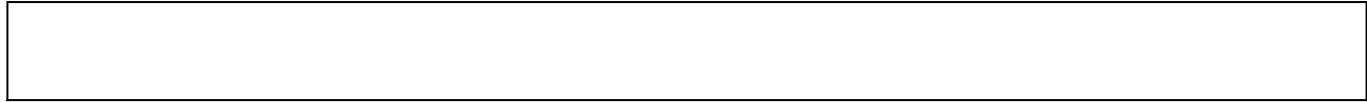

The quick start bit file configures the AD9517 to generate 250MHz clock to AD9250. It runs both the ADCs through all test modes and verifies the captured data accordingly. After the hardware setup, turn the power on..



Start IMPACT, and initialize the JTAG chain. The program should recognize the 7 series device. Start a UART terminal (set to 57600 baud rate) and then program the device. If programming was successful, you should be seeing messages appear on the terminal as shown in figure below. After programming the devices, the program checks data capture on various test modes.

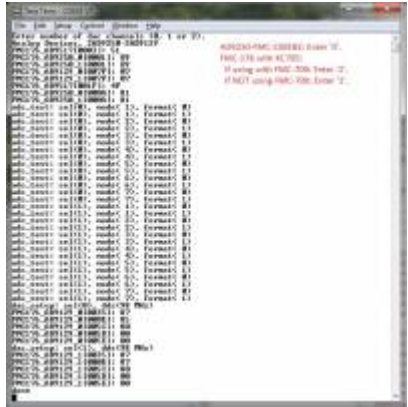

After patterns and prbs sequences are verified, if no errors are present, you may use the chipscope busplot to see the captured signal (see below). A chipscope project file is available inside the sw directory.

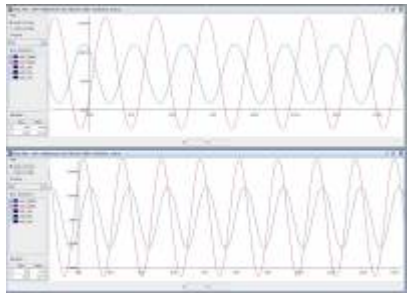

Using the reference design

The reference design is built on a microblaze based system parameterized for linux. A functional block diagram of the design is given below. The reference design contains both ADC and DAC pcores. If you are using the AD-FMCJESDADC1-EBZ, you can ignore the DAC pcores.

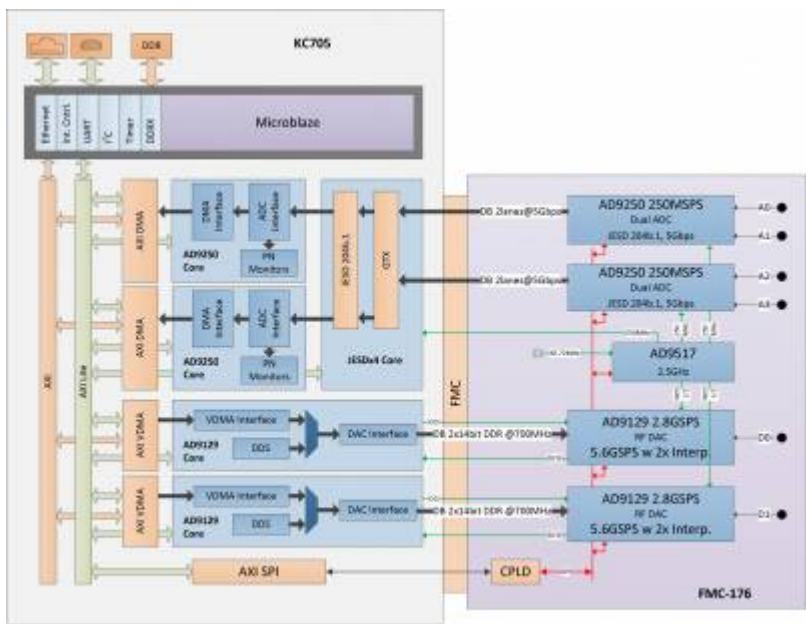

Configurations may differ for carrier/fmc board combinations.
Block diagram of boards are representative, not all components and connections are shown.

The reference design consists of two identical instances of pcores for the DAC. On the ADC side, it consists of a single JESD core (using Xilinx IP) and two identical instances of AD9250 pcores.

The AD9129 core consists of three functional modules, the DAC interface, a DDS (using Xilinx IP) and a VDMA interface. The frequency of DDS may be set via the programming interface. Alternatively a custom data sequence may be used via the VDMA interface.

The AD9250 core consists of three functional modules, the ADC interface, a PN9/PN23 monitor and a DMA interface. The ADC interface captures and buffers data from the JESD core. The DMA interface then transfers the samples to the external DDR-DRAM. The capture is initiated by the software. The status of capture (overflow, over the range) are reported back to the software.

All the pcores have an AXI lite interface that allows control and monitoring of data generation and/or capture.

The reference design also includes HDMI cores for GTX eye scan.

Registers

Please refer to the regmap.txt file in the pcores directory.

Changing ADC Sample Rates

The ADC sampling rate can vary from 40MHz to 250MHz. However, there are limitations imposed by the FPGA that may lower this range. In some cases, you may have to regenerate the cores for a different range. The reference design uses GTX (channel PLL) primitives and Xilinx's JESD core IP. The default design runs at 250MHz clock (5Gbps rate).

As of this writing, the GTX specification & switching characteristics may be found at:

http://www.xilinx.com/support/documentation/user_guides/ug476_7Series_Transceivers.pdf
http://www.xilinx.com/support/documentation/data_sheets/ds182_Kintex_7_Data_Sheet.pdf

The key switching characteristics are-

The reference clock has a range of 60MHz to 670MHz (700MHz). This limits the minimum sampling clock to 60MHz. Though it is NOT recommended, it is possible to use AD9517 to generate a 40MHz sampling clock to AD9250 and a 80MHz reference clock to the FPGA.

The line rate however, varies based on speed grade, package type and the use of CPLL vs QPLL. The CPLL supports rates between 0.5Gbps to 6.6Gbps (the core may have to be changed for rates less than 3.2Gbps (sampling rate 160MHz) - and the IP may not support all the combinations). Again, it is possible to run the device on a single lane at a higher rate (rather than 2 lanes each at a lower rate) to circumvent some of the troubles of line rate dependency on parametrization, package type and speed grade.

You must carefully evaluate these specifications against your requirements to run the design at a specific sampling frequency (or a range). As always, if you have any questions or run into any problems, [ask help & support](#).

JESD Interface

The default chipscope also captures the GTX/JESD core interface for a quick check on the transfer phases. There is a simple state machine within the pcore that walks through all the phases of the JESD specification. A sample screenshot is given below.

The default signals are:

The following signals are per lane (GTX). Refer to Xilinx documentation on details of these signals.	
rx_data	GTX receive data (32 bits).
rx_notintable	GTX receive data not in table (invalid 8B/10B).
rx_disperr	GTX receive disparity error.
rx_charisk	GTX receive data is a K character .
rx_fsm	The state machine (see the pcore module for details).
rx_sync_enb	SYNC enable (SYNC is driven by JESD core, but is enabled by the state machine).
rx_sysref_enb	SYSREF enable (SYSREF is driven by all lanes at the end of CGS).
rx_valid_k	If set, indicates a valid 'K' character on received data.
rx_cgs_k	If set, indicates CGS data on received data.
rx_ilas_r	If set, indicates 'R' character on received data.
rx_ilas_a	If set, indicates 'A' character on received data.
rx_ilas_q	If set, indicates 'Q' character on received data.
rx_ilas_f	If set, indicates 'F' character on received data.
The following signals are top level signals (common to all lanes)	
jesd204b_rxsync_s	The sync is generated by the IP core.



gtx_rst_s	The GTX reset (software controlled).
jesd204b_rst_s	The JESD core reset (software controlled AND GTX).
rxsync	JESD204b SYNC
rxsysref	JESD204b SYSREF

After reset (0x0), the FSM is at state 0x1, where it waits for CGS (Code Group Synchronization). After it finds a certain number of consecutive K characters (this ensures that the CGS phase is stable and lanes are all up and running), it asserts SYSREF and also enables SYNC. At state 3, it waits for SYNC to be deasserted. Note that enabling SYNC only allows the Xilinx core to drive the SYNC and do NOT deassert SYNC. The SYNC is soon deasserted by the JESD core and the FSM moves to state 4. At state 4, it is assumed that it is correctly done by the Xilinx IP core. At any point, if SYNC is asserted by the core, the process starts over.

Here is the sample screen shot:

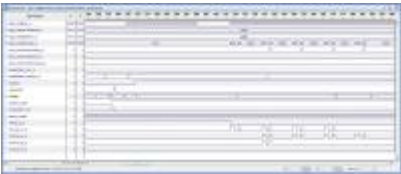

FMC-176 Information

The [4DSP FMC-176](#) is a high speed data acquisition (4 ADC channels at 250MSPS) and conversion (2 DAC channels at 5.6GSPS) card. This card features two [AD9250](#) and two [AD9129](#).

The [AD9129](#) is a high performance 14-bit RF DAC supporting data rates up to 2.8GSPS. The DAC core is based on a quad-switch architecture that enables dual-edge clocking operation effectively increasing the DAC update rate to 5.6 GSPS when configured for mix-mode or 2x interpolation. Its high dynamic range and bandwidth enables multicarrier generation up to and beyond 4.2 GHz. The AD9129 features two 14bit LVDS parallel interface.

The following variations of this board are available.

Part Number	ADC Channels	DAC Channels
FMC-176	4 (2 x AD9250)	2 (2 x AD9129)
FMC-230		2 (2 x AD9129)
AD-FMCJESDADC1-EBZ	4 (2 x AD9250)	

This reference design may be used as it is for FMC-176 and it's variations by selecting the appropriate number of DAC channels. It is also easy to port the design for other boards by removing one or more corresponding pcores. Also some devices may not be accessible depending on whether one choose to use LPC or HPC. To fully support both the DACs of the FMC-176, a carrier must have a fully populated HPC connector. The KC705 do not have a fully populated HPC.

The reference design includes (if enabled) RF generation via DDS and the SPI interface for the DACs. At the prompt just enter the number of DAC channels you have in your hardware setup. As an

example, if you are using FMC-176 with KC705, simply enter '1' as the number of DAC channels. If you are using the ADC only boards, enter '0' as the number of DAC channels.

The quick start bit file also configures the AD9517 to generate a 2.5GHz clock to AD9129. It then generates a 333MHz tone for the DAC.

The DAC spectrum for a 333MHz tone is shown below.

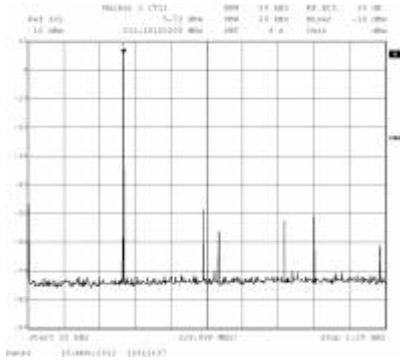

It is possible to use an adapter board such as FMC-700 with KC705 to access both the DACs on a FMC-176 board. However, the routing delays of FMC-LPC pins to the FMC-700 will cause timing errors on DAC1 and you may see parity errors on the UART terminal.

Dual AD-FMCJESDADC1-EBZ

In the downloads section, you will also find a dual AD-FMCJESDADC1-EBZ reference design for VC707. This design supports two AD-FMCJESDADC1-EBZ (4 x AD9250 devices) on VC707 using both the FMC1 and FMC2 connectors. It does NOT support any variations that includes AD9129.

The procedure is the same. The setup, UART and chipscope plots are shown below.

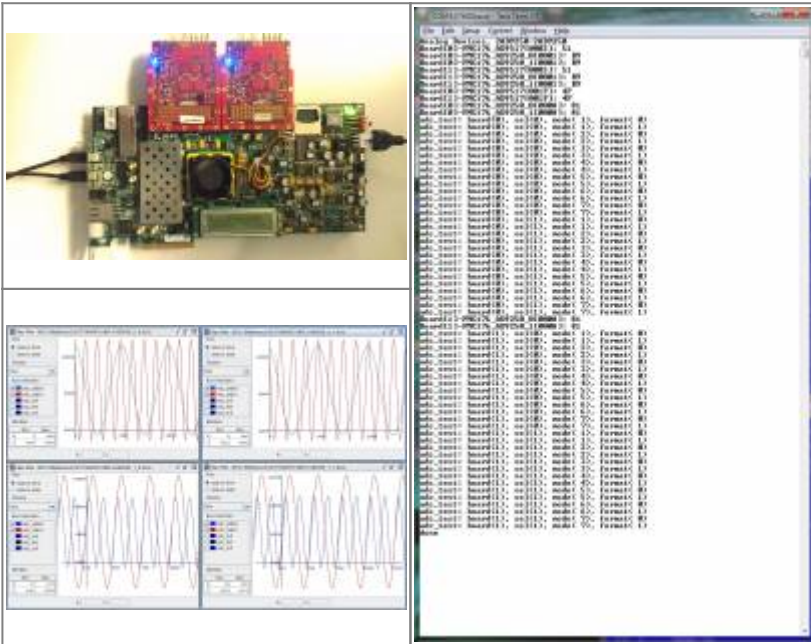

Downloads

FPGA Reference Designs:

- **ML605** [cf_fmc176_ml605_edk_14_4_2013_04_04.tar.gz](#)
- **KC705** [cf_fmc176_kc705_edk_14_4_2013_04_04.tar.gz](#)
- **VC707** [cf_fmc176_vc707_edk_14_4_2013_04_04.tar.gz](#)
- **VC707** [cf_fmc176x2_vc707_edk_14_4_2013_04_04.tar.gz](#)
- **ZC706** [cf_fmc176_zc706_edk_14_4_2013_04_04.tar.gz](#)

Software Files:

- **ML605** [cf_fmc176_ml605_sw_14_4_2013_04_04.tar.gz](#)
- **KC705** [cf_fmc176_kc705_sw_14_4_2013_04_04.tar.gz](#)
- **VC707** [cf_fmc176_vc707_sw_14_4_2013_04_04.tar.gz](#)
- **VC707** [cf_fmc176x2_vc707_sw_14_4_2013_04_04.tar.gz](#)
- **ZC706** [cf_fmc176_zc706_sw_14_4_2013_04_04.tar.gz](#)

Only Xilinx coregen xco files are provided with the reference design. You must regenerate the IP core files using this file. See [generating Xilinx netlist/verilog files from xco files](#) for details.

-  [Questions? Ask Help & Support.](#)

Tar file contents

The tar file contains, in most cases, the following files and/or directories. To rebuild the reference design simply double click the XMP file and run the tool. To build SDK, select a workspace and use the C file to build the elf file. Please refer to [Xilinx EDK documentation](#) for details.

license.txt	ADI license & copyright information.
system.mhs	MHS file.
system.xmp	XMP file (use this file to build the reference design).
data/	UCF file and/or DDR MIG project files.
docs/	Documentation files (Please note that this wiki page is the documentation for the reference design).
sw/	Software (Xilinx SDK) & bit file(s).
cf_lib/edk/pcores/	Reference design core file(s) (Xilinx EDK).

More information

- [VITA's FMC info](#)
- [Ask questions about the FPGA reference design](#)

© Analog Devices, Inc. All rights reserved. Trademarks and registered trademarks are the property of their respective owners.



www.analog.com