



Chipsmall Limited consists of a professional team with an average of over 10 year of expertise in the distribution of electronic components. Based in Hongkong, we have already established firm and mutual-benefit business relationships with customers from,Europe,America and south Asia,supplying obsolete and hard-to-find components to meet their specific needs.

With the principle of "Quality Parts,Customers Priority,Honest Operation,and Considerate Service",our business mainly focus on the distribution of electronic components. Line cards we deal with include Microchip,ALPS,ROHM,Xilinx,Pulse,ON,Everlight and Freescale. Main products comprise IC,Modules,Potentiometer,IC Socket,Relay,Connector.Our parts cover such applications as commercial,industrial, and automotives areas.

We are looking forward to setting up business relationship with you and hope to provide you with the best service and solution. Let us make a better world for our industry!



Contact us

Tel: +86-755-8981 8866 Fax: +86-755-8427 6832

Email & Skype: info@chipsmall.com Web: www.chipsmall.com

Address: A1208, Overseas Decoration Building, #122 Zhenhua RD., Futian, Shenzhen, China





Software-Defined Radio Solutions from Analog Devices

Software-Defined Radio Architectures Can Simplify Your System Design and Standardize Your Radio Platform

Software-defined radio (SDR) provides a reusable—and, to some extent, “future proof”—radio platform utilizing an RF to baseband transceiver and digital processor architecture. SDR can improve system performance, reduce system size, and minimize design risk and time to market by facilitating the use of available production-ready hardware and software reference radio designs. High end defense electronics, wired and wireless communications, and industrial and instrumentation applications have migrated to forms of SDR as their fundamental radio solution.

Software-defined radio architectures require that the analog-to-digital (ADC) and digital-to-analog (DAC) conversion stages be located close to the antenna, enabling direct RF or IF sampling. High dynamic range, high speed ADCs and DACs, amplifiers, mixers, and PLL devices and cores are the critical enablers of practical and robust SDR architectures. Analog Devices has led the industry in SDR-enabling products, from single chip integrated programmable wideband transceivers, to high performance components for discrete signal chain designs. And now we have gone a step further by providing our SDR solutions within a complete ecosystem of seamless FPGA connectivity, enabling a rapid prototyping and development environment for the complete radio system design.

This brochure highlights the range and depth of Analog Devices’ software-defined radio commitment: we offer rapid development and prototyping boards, IC products for discrete design, and tested reference designs.

Integrated Programmable Wideband Transceiver ICs

The **AD9361** (2×2) and **AD9364** (1×1) are high performance, highly integrated RF transceiver ICs intended for use in SDR architectures in applications such as wireless communications infrastructure, defense electronics systems, RF test equipment and instrumentation, and general software-defined radio platforms. The devices combine an RF front end with a flexible, mixed-signal baseband section and integrated frequency synthesizers, simplifying design-in by providing a configurable digital interface to a processor or FPGA. The chips operate in the 70 MHz to 6 GHz range, covering most licensed and unlicensed bands, and support channel bandwidths from less than 200 kHz to 56 MHz by changing sample rate, digital filters, and decimation, all programmable within the AD9361 and AD9364 devices.

IC Features

- Complete dual- or single-channel integrated wideband transceiver on a single chip
- Tunable band: 70 MHz to 6 GHz; 200 kHz to 56 MHz channel bandwidth
- Superior receiver sensitivity with a noise figure < 2.5 dB
- Highly linear broadband transmitter:
 - Transmitter EVM: ≤ -40 dB
 - Transmitter noise: ≤ -157 dBm/Hz noise floor
 - Transmitter monitor: ≥ 66 dB dynamic range with 1 dB accuracy
- Phase and frequency synchronization on both transmit and receive paths
- Supports MIMO radio, with less than one sample sync on both ADC and DAC
- Supports TDD and FDD operation integrated fractional-N synthesizers with 2.5 Hz maximum local oscillator (LO) step size



2 × 2 Agile RF Transceiver IC



1 × 1 Agile RF Transceiver IC

Applications

- General-purpose design suitable for any software-defined radio application
- MIMO radio
- Point-to-point communication systems
- Femtocell/picocell/microcell base stations
- Wi-Fi
- ISM

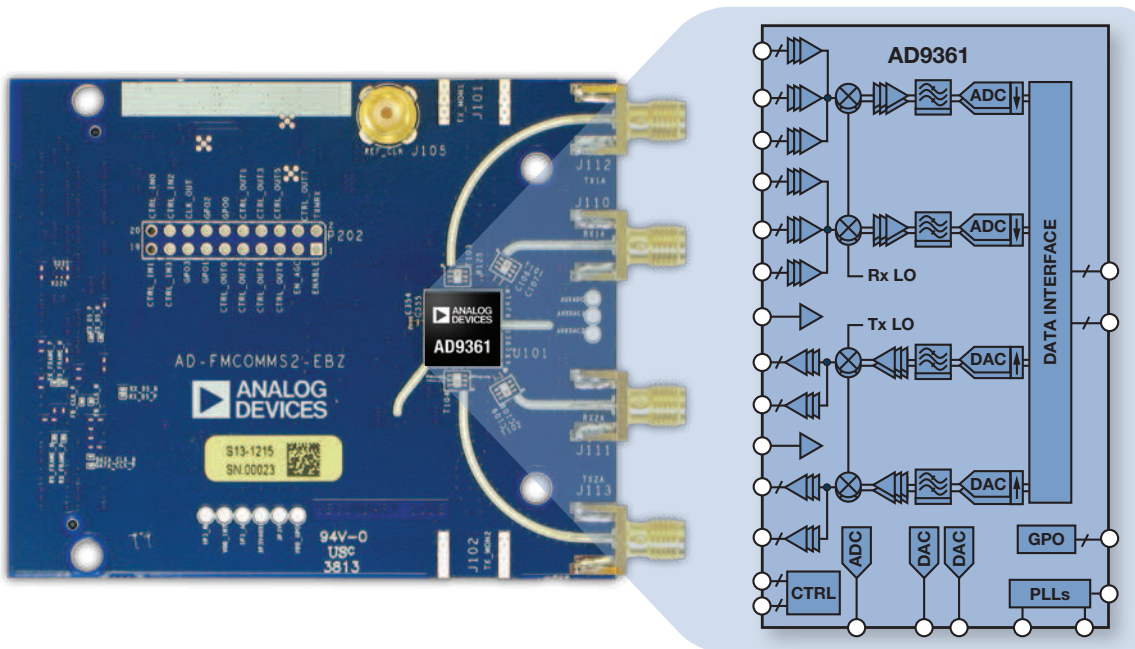

The **AD9361** is ADI's programmable 2×2 integrated transceiver solution spanning the 70 MHz to 6 GHz band. This flexible, high performance IC is featured on the **AD-FMCOMMS2-EBZ** board for seamless connection to a Xilinx® FPGA development platform, facilitating rapid SDR prototyping and system development.

Rapid Development Boards Provide a Complete SDR Reference Design

The AD-FMCOMMSx-EBZ rapid development and prototyping boards are a family of high speed analog FMC modules, incorporating the AD9361 or AD9364 agile RF transceiver ICs, or a discrete signal chain, that seamlessly connects to the Xilinx FPGA development platform ecosystem. These boards are fully customizable by software without any hardware changes and come with downloadable Linux® drivers and bare metal software drivers, schematics, board layout, and design-aid reference materials, all contained on their respective Analog Devices wiki sites.



AD-FMCOMMS2-EBZ connected to Xilinx Zynq®-7000 All Programmable SoC.

Features

- FMC format SDR development platform includes schematics, layout, BOM, HDL, Linux drivers, and application software
- Supports add-on cards for spectrum specific designs such as PA and LNA
- SPI access for all device registers

Design and Simulation Tools

SimRF™ by MathWorks

Now you can build models of Analog Devices wideband agile RF transceivers based on data sheet parameters and integrate them into your wireless system designs using MathWork's MATLAB, SimRF, and Simulink design environment. Watch the webcast to learn how:

<http://www.mathworks.com/videos/modelling-and-simulating-analog-devices-rf-transceivers-with-matlab-and-simrf-89934.html>

RF Transceiver FIR Filter Design

Perform FIR filter design using MATLAB from MathWorks using a model of the AD9361 and AD9364 RF transceivers. Watch the webcast to learn how: http://www.analog.com/en/content/WC_Digital_Filter_Design/webcast.html

ADI's Portfolio of SDR Rapid Prototyping Platforms

Part Number	Description
AD-FMCOMMS5-EBZ	Integrating two AD9361 2 × 2 agile transceiver ICs, this SDR rapid prototyping board provides full synchronization capability for 4 receiver channels and 4 transmitter channels, enabling any subset of a 4 × 4 MIMO system to be created. Wideband 70 MHz to 6 GHz and 2.4 GHz-tuned ports are accommodated. AD-FMCOMMS5-EBZ resource wiki page: http://wiki.analog.com/resources/eval/user-guides/ad-fmcomms5-ebz
AD-FMCOMMS4-EBZ	Integrating the AD9364 agile RF transceiver IC, this 1 × 1 SDR rapid prototyping board can be software configured for highest RF performance in the 2400 MHz to 2500 MHz region, or can be software configured to operate over the AD9364's complete RF tuning range of 70 MHz to 6 GHz for system prototyping and development purposes. AD-FMCOMMS4-EBZ resource wiki page: http://wiki.analog.com/resources/eval/user-guides/ad-fmcomms4-ebz
AD-FMCOMMS3-EBZ	Integrating the AD9361 agile RF transceiver IC, this 2 × 2 version of SDR rapid prototyping board supports the AD9361's full RF tuning range of 70 MHz to 6 GHz. This kit is ideal for the wireless communications SDR system architect seeking a unified development platform with wide tuning capabilities. The AES-ZSDR3-ADI-G SDR system development kit from Avnet includes the AD-FMCOMMS3-EBZ, Xilinx ZC706 development board, Xilinx Vivado software, four Pulse 4G LTE blade antennas, and reference designs for Zynq™-7000 All Programmable SoC running Linux. AD-FMCOMMS3-EBZ resource wiki page: http://wiki.analog.com/resources/eval/user-guides/ad-fmcomms3-ebz
AD-FMCOMMS2-EBZ	Integrating the AD9361 agile RF transceiver IC, this 2 × 2 SDR rapid prototyping board is tuned for highest RF performance in the 2400 MHz to 2500 MHz region. This kit is ideal for the RF engineer seeking optimized system performance meeting AD9361 data sheet specifications within this defined range of RF spectrum. The AES-ZSDR2-ADI-G SDR evaluation kit from Avnet includes the AD-FMCOMMS2-EBZ, a ZedBoard™ Xilinx Vivado® software, four Pulse 4G LTE blade antennas, and reference designs for Zynq-7000 All Programmable SoC running Linux. AD-FMCOMMS2-EBZ resource wiki page: http://wiki.analog.com/resources/eval/user-guides/ad-fmcomms2-ebz
AD-FMCOMMS1-EBZ	Composed of discrete high speed ADI components, this board provides a hardware platform that addresses a broad range of research, academic, industrial, and defense RF applications over the band of 400 MHz to 4 GHz. AD-FMCOMMS1-EBZ resource wiki page: http://wiki.analog.com/resources/fpga/xilinx/fmc/ad-fmcomms1-ebz

ICs for Discrete Software-Defined Radio Signal Chain Designs

When you have unique SDR requirements, or configurability isn't essential, ADI has the industry's largest portfolio of transceivers, data converters, amplifiers, synthesizers, and other high performance RF ICs to meet the needs of the most demanding signal chain designs. Examples of our RF signal chain components include:

High Speed Data Converters

- **AD9680**—dual, 14-bit, 1.0 GSPS ADC with JESD204B serial output interface
- **AD9144**—quad, 16-bit, 2.0 GSPS TxDAC+[®] transmit DAC with JESD204B serial output interface
- **AD9625**—dual, 14-bit, 2.5 GSPS ADC with JESD204B serial output interface

PLLs

- **ADF4351**, **ADF4355-2**—wideband synthesizer with integrated VCOs

RF Amplifiers

- **ADL5601**, **ADL5602**—50 MHz to 4 GHz broadband 20 dB linear amplifiers
- **ADL5320**—400 MHz to 2700 MHz, ¼ W RF driver amplifier
- **ADL5604**—700 MHz to 2700 MHz, 1 W RF driver amplifier
- **ADL5610**, **ADL5611**—30 MHz to 6 GHz RF amplifiers for high performance applications
- **ADL5544**, **ADL5545**—30 MHz to 6 GHz RF amplifiers for low power applications

Low Noise Amplifiers

- **ADL5523**, **ADL5521**—400 MHz to 4000 MHz low noise amplifiers

ADC Driver Amplifiers

- **AD8366**—dual variable gain amplifier
- **ADA4961**—low distortion, dc to 2.5 GHz ADC driver amplifier

Power Detector

- **ADL5501**—50 MHz to 6 GHz TruPwr[™] detector

Clocking

- **AD9523**—low jitter clock generator with 14 outputs

Integrated ISM Band Transceivers

- **ADF7023**—transceiver operating in the license free ISM bands

Power Management

- **ADP5040**—1.2 A buck regulator and dual 200 mA LDOs

Online RF Design Support

RF Design Tools

ADI's comprehensive suite of RF design tools help reduce design risk and time to market by enabling a simpler, faster, more accurate, and more robust design process. Featured tools include: ADIsimRF[™], ADIsimPLL[™], ADIsimSRD[™] Design Studio, and ADIsimCLK[™]. Visit www.analog.com/rftools.

Circuits from the Lab[®] Reference Designs

Hundreds of reference designs engineered by ADI application experts, addressing your most challenging needs. [View our collection of RF circuits.](#)



ADI's EngineerZone[®] Support Community helps engineers get answers to technical questions about Analog Devices products and connect with their fellow engineers and experts around the globe. ez.analog.com.

**Analog Devices, Inc.
Worldwide Headquarters**
Analog Devices, Inc.
One Technology Way
P.O. Box 9106
Norwood, MA 02062-9106
U.S.A.
Tel: 781.329.4700
(800.262.5643,
U.S.A. only)
Fax: 781.461.3113

**Analog Devices, Inc.
Europe Headquarters**
Analog Devices, Inc.
Wilhelm-Wagenfeld-Str. 6
80807 Munich
Germany
Tel: 49.89.76903.0
Fax: 49.89.76903.157

**Analog Devices, Inc.
Japan Headquarters**
Analog Devices, KK
New Pier Takeshiba
South Tower Building
1-16-1 Kaigan, Minato-ku,
Tokyo, 105-6891
Japan
Tel: 813.5402.8200
Fax: 813.5402.1064

**Analog Devices, Inc.
Asia Pacific Headquarters**
Analog Devices
5F, Sandhill Plaza
2290 Zuchongzhi Road
Zhangjiang Hi-Tech Park
Pudong New District
Shanghai, China 201203
Tel: 86.21.2320.8000
Fax: 86.21.2320.8222