



Chipsmall Limited consists of a professional team with an average of over 10 year of expertise in the distribution of electronic components. Based in Hongkong, we have already established firm and mutual-benefit business relationships with customers from,Europe,America and south Asia,supplying obsolete and hard-to-find components to meet their specific needs.

With the principle of “Quality Parts,Customers Priority,Honest Operation,and Considerate Service”,our business mainly focus on the distribution of electronic components. Line cards we deal with include Microchip,ALPS,ROHM,Xilinx,Pulse,ON,Everlight and Freescale. Main products comprise IC,Modules,Potentiometer,IC Socket,Relay,Connector.Our parts cover such applications as commercial,industrial, and automotives areas.

We are looking forward to setting up business relationship with you and hope to provide you with the best service and solution. Let us make a better world for our industry!



## Contact us

Tel: +86-755-8981 8866 Fax: +86-755-8427 6832

Email & Skype: info@chipsmall.com Web: www.chipsmall.com

Address: A1208, Overseas Decoration Building, #122 Zhenhua RD., Futian, Shenzhen, China



## FEATURES

- PLL generated or direct master clock**
- Low EMI design**
- 108 dB DAC/107 dB ADC dynamic range and SNR**
- 94 dB THD + N**
- 3.3 V single supply**
- Tolerance for 5 V logic inputs**
- Supports 24 bits and 8 kHz to 192 kHz sample rates**
- Differential ADC input**
- Single-ended DAC output**
- Log volume control with autoramp function**
- SPI controllable for flexibility**
- Software-controllable clickless mute**
- Software power-down**
- Right-justified, left-justified, I<sup>2</sup>S-justified, and TDM modes**
- Master and slave modes up to 16-channel input/output**
- 48-lead LQFP package**
- Qualified for automotive applications**

## APPLICATIONS

- Automotive audio systems**
- Home Theater Systems**
- Set-top boxes**
- Digital audio effects processors**

## GENERAL DESCRIPTION

The **AD1938** is a high performance, single-chip codec that provides four analog-to-digital converters (ADCs) with input and eight digital-to-analog converters (DACs) with single-ended output using the Analog Devices, Inc., patented multibit sigma-delta ( $\Sigma$ - $\Delta$ ) architecture. An SPI port is included, allowing a microcontroller to adjust volume and many other parameters.

The **AD1938** operates from 3.3 V digital and analog supplies. The **AD1938** is available in a 48-lead (single-ended output) LQFP package. Other members of this family include a differential DAC output and I<sup>2</sup>C<sup>®</sup> control port version.

The **AD1938** is designed for low EMI. This consideration is apparent in both the system and circuit design architectures. By using the on-board PLL to derive the master clock from the LR clock or from an external crystal, the **AD1938** eliminates the need for a separate high frequency master clock and can also be used with a suppressed bit clock. The DACs and ADCs are designed using the latest Analog Devices continuous time architectures to further minimize EMI. By using 3.3 V supplies, power consumption is minimized, further reducing emissions.

## FUNCTIONAL BLOCK DIAGRAM

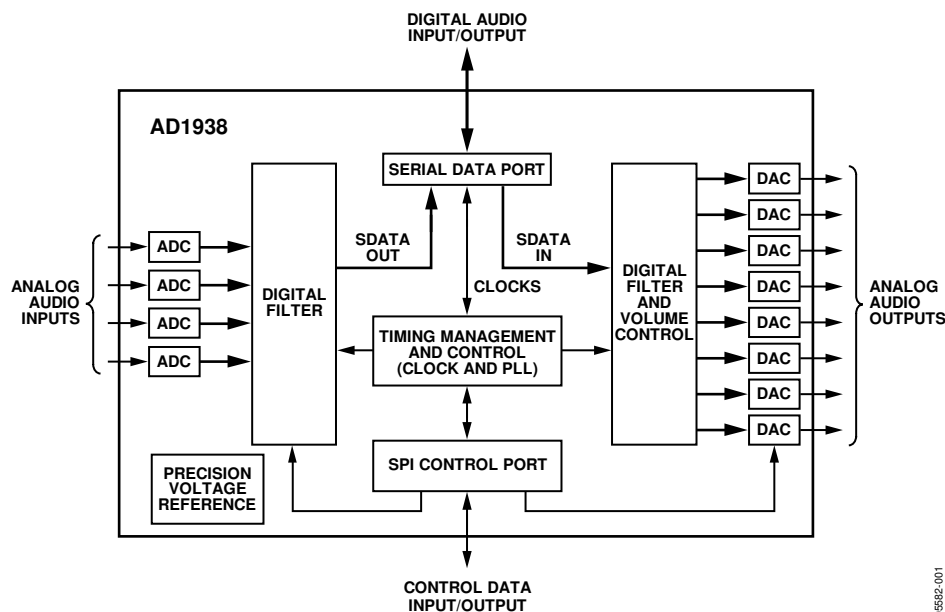

Figure 1.

Rev. E

[Document Feedback](#)

Information furnished by Analog Devices is believed to be accurate and reliable. However, no responsibility is assumed by Analog Devices for its use, nor for any infringements of patents or other rights of third parties that may result from its use. Specifications subject to change without notice. No license is granted by implication or otherwise under any patent or patent rights of Analog Devices. Trademarks and registered trademarks are the property of their respective owners.

One Technology Way, P.O. Box 9106, Norwood, MA 02062-9106, U.S.A.  
 Tel: 781.329.4700 ©2006–2013 Analog Devices, Inc. All rights reserved.  
[Technical Support](#) [www.analog.com](http://www.analog.com)

# AD1938\* PRODUCT PAGE QUICK LINKS

Last Content Update: 02/23/2017

---

## COMPARABLE PARTS

View a parametric search of comparable parts.

## EVALUATION KITS

- AD1938 Evaluation Board
- ADUSB2EBZ Evaluation Board

## DOCUMENTATION

### Application Notes

- AN-1006: Using the EVAL-ADUSB2EBZ
- AN-1365: AD1933/AD1934/AD1938/AD1939/AD1974 Boot Up Application

### Data Sheet

- AD1938: 4 ADC/8 DAC with PLL, 192 kHz, 24-Bit Codec Data Sheet

### User Guides

- UG-045: Evaluating the AD1938 Four ADC/Eight DAC with PLL 192 kHz, 24-Bit Codec
- UG-087: Evaluating the AD1940 SigmaDSP Using the EVAL-AD1940MINIBZ

## SOFTWARE AND SYSTEMS REQUIREMENTS

- Automated Register Window Builder

## TOOLS AND SIMULATIONS

- AD1938 IBIS Model

## REFERENCE MATERIALS

### Technical Articles

- Benchmarking Integrated Audio: Why CPU Usage Alone No Longer Predicts User Experience

## DESIGN RESOURCES

- AD1938 Material Declaration
- PCN-PDN Information
- Quality And Reliability
- Symbols and Footprints

## DISCUSSIONS

View all AD1938 EngineerZone Discussions.

## SAMPLE AND BUY

Visit the product page to see pricing options.

## TECHNICAL SUPPORT

Submit a technical question or find your regional support number.

## DOCUMENT FEEDBACK

Submit feedback for this data sheet.

## TABLE OF CONTENTS

Features .....	1	Analog-to-Digital Converters (ADCs).....	13
Applications.....	1	Digital-to-Analog Converters (DACs).....	13
General Description .....	1	Clock Signals.....	13
Functional Block Diagram .....	1	Reset and Power-Down .....	14
Revision History .....	2	Serial Control Port .....	14
Specifications.....	3	Power Supply and Voltage Reference.....	15
Test Conditions.....	3	Serial Data Ports—Data Format.....	15
Analog Performance Specifications .....	3	Time-Division Multiplexed (TDM) Modes.....	15
Crystal Oscillator Specifications.....	4	Daisy-Chain Mode .....	19
Digital Input/Output Specifications.....	5	Control Registers.....	24
Power Supply Specifications.....	5	Definitions.....	24
Digital Filters.....	6	PLL and Clock Control Registers.....	24
Timing Specifications .....	7	DAC Control Registers.....	25
Absolute Maximum Ratings.....	8	ADC Control Registers.....	27
Thermal Resistance .....	8	Additional Modes.....	29
ESD Caution.....	8	Applications Circuits.....	30
Pin Configuration and Function Descriptions.....	9	Outline Dimensions .....	31
Typical Performance Characteristics .....	11	Ordering Guide .....	31
Theory of Operation .....	13		

## REVISION HISTORY

### 2/13—Rev. D to Rev. E

Change to $t_{CLH}$ Parameter, Table 7 .....	7
--	---

### 7/11—Rev. C to Rev. D

Changes to Table 10, DSDATAx/ASDATAx Pin Descriptions... ..	9
---	---

### 1/11—Rev. B to Rev. C

Added Automotive Information .....	Throughout
Change to Table 2, Introductory Text .....	4
Change to Table 4, Introductory Text .....	5
Change to Table 7, Introductory Text .....	7
Changes to Ordering Guide .....	31

### 8/09—Rev. A to Rev. B

Changes to Table 16 Title.....	24
Changes to Figure 18 and Table 19 Titles.....	25
Changes to Table 20 Title.....	26
Changes to Table 23 and Table 24 Titles.....	27
Changes to Table 25 Title.....	28
Changes to Ordering Guide .....	31

### 7/08—Rev. 0 to Rev. A

Changes to Table 7.....	7
Changes to Figure 2.....	9
Changes to Table 10 .....	9
Changes to Clock Signals Section .....	13
Changes to Reset and Power-Down Section.....	14
Change to Serial Control Port Section .....	14
Changes to Table 11 .....	14
Changes to Figure 24 and Figure 25 .....	22
Changes to Figure 26.....	23
Changes to Definitions Section .....	24
Changes to Table 16 .....	24
Change to Additional Modes Section.....	29
Change to Figure 30 .....	30

### 5/06—Revision 0: Initial Version

## SPECIFICATIONS

### TEST CONDITIONS

Performance of all channels is identical, exclusive of the interchannel gain mismatch and interchannel phase deviation specifications.

Supply voltages (AVDD, DVDD)	3.3 V
Temperature range <sup>1</sup>	as specified in Table 1 and Table 2
Master clock	12.288 MHz (48 kHz $f_s$ , 256 × $f_s$ mode)
Input sample rate	48 kHz
Measurement bandwidth	20 Hz to 20 kHz
Word width	24 bits
Load capacitance (digital output)	20 pF
Load current (digital output)	±1 mA or 1.5 kΩ to ½ DVDD supply
Input voltage high	2.0 V
Input voltage low	0.8 V

<sup>1</sup> Functionally guaranteed at –40°C to +125°C case temperature.

### ANALOG PERFORMANCE SPECIFICATIONS

Specifications guaranteed at an ambient temperature of 25°C.

Table 1.

Parameter	Conditions	Min	Typ	Max	Unit
<b>ANALOG-TO-DIGITAL CONVERTERS</b>					
ADC Resolution	All ADCs		24		Bits
Dynamic Range	20 Hz to 20 kHz, –60 dB input				
No Filter (RMS)		98	102		dB
With A-Weighted Filter (RMS)		100	105		dB
Total Harmonic Distortion + Noise	–1 dBFS		–96	–87	dB
Full-Scale Input Voltage (Differential)			1.9		V rms
Gain Error		–10		+10	%
Interchannel Gain Mismatch		–0.25		+0.25	dB
Offset Error		–10	0	+10	mV
Gain Drift			100		ppm/°C
Interchannel Isolation			–110		dB
CMRR	100 mV rms, 1 kHz		55		dB
	100 mV rms, 20 kHz		55		dB
Input Resistance			14		kΩ
Input Capacitance			10		pF
Input Common-Mode Bias Voltage			1.5		V
<b>DIGITAL-TO-ANALOG CONVERTERS</b>					
Dynamic Range	20 Hz to 20 kHz, –60 dB input				
No Filter (RMS)		98	104		dB
With A-Weighted Filter (RMS)		100	106		dB
With A-Weighted Filter (Average)			108		dB
Total Harmonic Distortion + Noise	0 dBFS				
Single-Ended Version	Two channels running		–92		dB
Single-Ended Version	Eight channels running		–86	–75	dB
Full-Scale Output Voltage			0.88 (2.48)		V rms (V p-p)
Gain Error		–10		+10	%
Interchannel Gain Mismatch		–0.2		+0.2	dB
Offset Error		–25	–4	+25	mV
Gain Drift		–30		+30	ppm/°C

Parameter	Conditions	Min	Typ	Max	Unit
Interchannel Isolation			100		dB
Interchannel Phase Deviation			0		Degrees
Volume Control Step			0.375		dB
Volume Control Range			95		dB
De-emphasis Gain Error				±0.6	dB
Output Resistance at Each Pin			100		Ω
REFERENCE					
Internal Reference Voltage	FILTR pin		1.50		V
External Reference Voltage	FILTR pin	1.32	1.50	1.68	V
Common-Mode Reference Output	CM pin		1.50		V

Specifications measured at a case temperature of 125°C.

**Table 2.**

Parameter	Conditions	Min	Typ	Max	Unit
ANALOG-TO-DIGITAL CONVERTERS					
ADC Resolution	All ADCs		24		Bits
Dynamic Range	20 Hz to 20 kHz, –60 dB input				
No Filter (RMS)		95	102		dB
With A-Weighted Filter (RMS)		97	105		dB
Total Harmonic Distortion + Noise	–1 dBFS		–96	–87	dB
Full-Scale Input Voltage (Differential)			1.9		V rms
Gain Error		–10		+10	%
Interchannel Gain Mismatch		–0.25		+0.25	dB
Offset Error		–10	0	+10	mV
DIGITAL-TO-ANALOG CONVERTERS					
Dynamic Range	20 Hz to 20 kHz, –60 dB input				
No Filter (RMS)		98	104		dB
With A-Weighted Filter (RMS)		100	106		dB
With A-Weighted Filter (Average)			108		dB
Total Harmonic Distortion + Noise	0 dBFS				
Single-Ended Version	Two channels running		–92		dB
Single-Ended Version	Eight channels running		–86	–70	dB
Full-Scale Output Voltage			0.8775 (2.482)		V rms (V p-p)
Gain Error		–10		+10	%
Interchannel Gain Mismatch		–0.2		+0.2	dB
Offset Error		–25	–4	25	mV
Gain Drift		–30		30	ppm/°C
REFERENCE					
Internal Reference Voltage	FILTR pin		1.50		V
External Reference Voltage	FILTR pin	1.32	1.50	1.68	V
Common-Mode Reference Output	CM pin		1.50		V

## CRYSTAL OSCILLATOR SPECIFICATIONS

**Table 3.**

Parameter	Min	Typ	Max	Unit
Transconductance		3.5		mmhos

**DIGITAL INPUT/OUTPUT SPECIFICATIONS**

$-40^{\circ}\text{C} < T_c < +125^{\circ}\text{C}$ , DVDD = 3.3 V  $\pm$  10%.

Table 4.

Parameter	Conditions/Comments	Min	Typ	Max	Unit
High Level Input Voltage ( $V_{IH}$ )		2.0			V
High Level Input Voltage ( $V_{IH}$ )	MCLKI/XI pin	2.2			V
Low Level Input Voltage ( $V_{IL}$ )				0.8	V
Input Leakage	$I_{IH}$ @ $V_{IH} = 2.4$ V $I_{IL}$ @ $V_{IL} = 0.8$ V			10	$\mu\text{A}$
High Level Output Voltage ( $V_{OH}$ )	$I_{OH} = 1$ mA	DVDD – 0.60			V
Low Level Output Voltage ( $V_{OL}$ )	$I_{OL} = 1$ mA			0.4	V
Input Capacitance				5	pF

**POWER SUPPLY SPECIFICATIONS**

Table 5.

Parameter	Conditions/Comments	Min	Typ	Max	Unit
<b>SUPPLIES</b>					
Voltage	DVDD	3.0	3.3	3.6	V
	AVDD	3.0	3.3	3.6	V
Digital Current	Master clock = 256 $f_s$				
Normal Operation	$f_s = 48$ kHz		56		mA
	$f_s = 96$ kHz		65		mA
	$f_s = 192$ kHz		95		mA
Power-Down	$f_s = 48$ kHz to 192 kHz		2.0		mA
Analog Current					
Normal Operation			74		mA
Power-Down			23		mA
<b>DISSIPATION</b>					
Operation	Master clock = 256 $f_s$ , 48 kHz				
All Supplies			429		mW
Digital Supply			185		mW
Analog Supply			244		mW
Power-Down, All Supplies			83		mW
<b>POWER SUPPLY REJECTION RATIO</b>					
Signal at Analog Supply Pins	1 kHz, 200 mV p-p		50		dB
	20 kHz, 200 mV p-p		50		dB

## DIGITAL FILTERS

Table 6.

Parameter	Mode	Factor	Min	Typ	Max	Unit
ADC DECIMATION FILTER	All modes, typical @ 48 kHz					
Pass Band		$0.4375 f_s$		21		kHz
Pass-Band Ripple				$\pm 0.015$		dB
Transition Band		$0.5 f_s$		24		kHz
Stop Band		$0.5625 f_s$		27		kHz
Stop-Band Attenuation			79			dB
Group Delay		$22.9844/f_s$		479		$\mu s$
DAC INTERPOLATION FILTER						
Pass Band	48 kHz mode, typical @ 48 kHz	$0.4535 f_s$		22		kHz
	96 kHz mode, typical @ 96 kHz	$0.3646 f_s$	35			kHz
	192 kHz mode, typical @ 192 kHz	$0.3646 f_s$		70		kHz
Pass-Band Ripple	48 kHz mode, typical @ 48 kHz				$\pm 0.01$	dB
	96 kHz mode, typical @ 96 kHz				$\pm 0.05$	dB
	192 kHz mode, typical @ 192 kHz				$\pm 0.1$	dB
Transition Band	48 kHz mode, typical @ 48 kHz	$0.5 f_s$		24		kHz
	96 kHz mode, typical @ 96 kHz	$0.5 f_s$		48		kHz
	192 kHz mode, typical @ 192 kHz	$0.5 f_s$		96		kHz
Stop Band	48 kHz mode, typical @ 48 kHz	$0.5465 f_s$		26		kHz
	96 kHz mode, typical @ 96 kHz	$0.6354 f_s$		61		kHz
	192 kHz mode, typical @ 192 kHz	$0.6354 f_s$		122		kHz
Stop-Band Attenuation	48 kHz mode, typical @ 48 kHz		70			dB
	96 kHz mode, typical @ 96 kHz		70			dB
	192 kHz mode, typical @ 192 kHz		70			dB
Group Delay	48 kHz mode, typical @ 48 kHz	$25/f_s$		521		$\mu s$
	96 kHz mode, typical @ 96 kHz	$11/f_s$		115		$\mu s$
	192 kHz mode, typical @ 192 kHz	$8/f_s$		42		$\mu s$



## TIMING SPECIFICATIONS

-40°C < T<sub>c</sub> < +125°C, DVDD = 3.3 V ± 10%.

Table 7.

Parameter	Condition	Comments	Min	Max	Unit
<b>INPUT MASTER CLOCK (MCLK) AND RESET</b>					
t <sub>MH</sub>	MCLK duty cycle	DAC/ADC clock source = PLL clock @ 256 f <sub>s</sub> , 384 f <sub>s</sub> , 512 f <sub>s</sub> , and 768 f <sub>s</sub>	40	60	%
t <sub>MH</sub>		DAC/ADC clock source = direct MCLK @ 512 f <sub>s</sub> (bypass on-chip PLL)	40	60	%
f <sub>MCLK</sub>	MCLK frequency	PLL mode, 256 f <sub>s</sub> reference	6.9	13.8	MHz
f <sub>MCLK</sub>		Direct 512 f <sub>s</sub> mode		27.6	MHz
t <sub>PDR</sub>	$\overline{\text{RST}}$ low		15		ns
t <sub>PDRR</sub>	$\overline{\text{RST}}$ recovery	Reset to active output	4096		t <sub>MCLK</sub>
<b>PLL</b>					
Lock time	MCLK and LR clock input			10	ms
256 f <sub>s</sub> VCO Clock, Output Duty Cycle, MCLKO/XO Pin			40	60	%
<b>SPI PORT</b>					
t <sub>CCH</sub>	CCLK high	See Figure 11	35		ns
t <sub>CCL</sub>	CCLK low		35		ns
f <sub>CCLK</sub>	CCLK frequency	f <sub>CCLK</sub> = 1/t <sub>CCP</sub> , only t <sub>CCP</sub> shown in Figure 11		10	MHz
t <sub>CDS</sub>	CIN setup	To CCLK rising	10		ns
t <sub>CDH</sub>	CIN hold	From CCLK rising	10		ns
t <sub>CLS</sub>	$\overline{\text{CLATCH}}$ setup	To CCLK rising	10		ns
t <sub>CLH</sub>	$\overline{\text{CLATCH}}$ hold	From CCLK rising	10		ns
t <sub>CLH</sub>	$\overline{\text{CLATCH}}$ high	Not shown in Figure 11	10		ns
t <sub>COE</sub>	COUT enable	From CCLK falling		30	ns
t <sub>COD</sub>	COUT delay	From CCLK falling		30	ns
t <sub>COH</sub>	COUT hold	From CCLK falling, not shown in Figure 11	30		ns
t <sub>COTS</sub>	COUT tristate	From CCLK falling		30	ns
<b>DAC SERIAL PORT</b>					
t <sub>DBH</sub>	DBCLK high	See Figure 24	10		ns
t <sub>DBL</sub>	DBCLK low	Slave mode	10		ns
t <sub>DLS</sub>	DLRCLK setup	To DBCLK rising, slave mode	10		ns
t <sub>DLH</sub>	DLRCLK hold	From DBCLK rising, slave mode	5		ns
t <sub>DLS</sub>	DLRCLK skew	From DBCLK falling, master mode	-8	+8	ns
t <sub>DDS</sub>	DSDATA setup	To DBCLK rising	10		ns
t <sub>DDH</sub>	DSDATA hold	From DBCLK rising	5		ns
<b>ADC SERIAL PORT</b>					
t <sub>ABH</sub>	ABCLK high	See Figure 25	10		ns
t <sub>ABL</sub>	ABCLK low	Slave mode	10		ns
t <sub>ALS</sub>	ALRCLK setup	To ABCLK rising, slave mode	10		ns
t <sub>ALH</sub>	ALRCLK hold	From ABCLK rising, slave mode	5		ns
t <sub>ALS</sub>	ALRCLK skew	From ABCLK falling, master mode	-8	+8	ns
t <sub>ABDD</sub>	ASDATA delay	From ABCLK falling		18	ns
<b>AUXILIARY INTERFACE</b>					
t <sub>AXDS</sub>	AAUXDATA setup	To AUXBCLK rising	10		ns
t <sub>AXDH</sub>	AAUXDATA hold	From AUXBCLK rising	5		ns
t <sub>DXDD</sub>	DAUXDATA delay	From AUXBCLK falling		18	ns
t <sub>XBH</sub>	AUXBCLK high		10		ns
t <sub>XBL</sub>	AUXBCLK low		10		ns
t <sub>DLS</sub>	AUXLRCLK setup	To AUXBCLK rising	10		ns
t <sub>DLH</sub>	AUXLRCLK hold	From AUXBCLK rising	5		ns

## ABSOLUTE MAXIMUM RATINGS

Table 8.

Parameter	Rating
Analog (AVDD)	−0.3 V to +3.6 V
Digital (DVDD)	−0.3 V to +3.6 V
Input Current (Except Supply Pins)	±20 mA
Analog Input Voltage (Signal Pins)	−0.3 V to AVDD + 0.3 V
Digital Input Voltage (Signal Pins)	−0.3 V to DVDD + 0.3 V
Operating Temperature Range (Case)	−40°C to +125°C
Storage Temperature Range	−65°C to +150°C

Stresses above those listed under Absolute Maximum Ratings may cause permanent damage to the device. This is a stress rating only; functional operation of the device at these or any other conditions above those indicated in the operational section of this specification is not implied. Exposure to absolute maximum rating conditions for extended periods may affect device reliability.

## THERMAL RESISTANCE

$\theta_{JA}$  represents thermal resistance, junction-to-ambient;  $\theta_{JC}$  represents the thermal resistance, junction-to-case. All characteristics are for a 4-layer board.

Table 9. Thermal Resistance

Package Type	$\theta_{JA}$	$\theta_{JC}$	Unit
48-Lead LQFP	50.1	17	°C/W

## ESD CAUTION



**ESD (electrostatic discharge) sensitive device.** Charged devices and circuit boards can discharge without detection. Although this product features patented or proprietary protection circuitry, damage may occur on devices subjected to high energy ESD. Therefore, proper ESD precautions should be taken to avoid performance degradation or loss of functionality.

## PIN CONFIGURATION AND FUNCTION DESCRIPTIONS

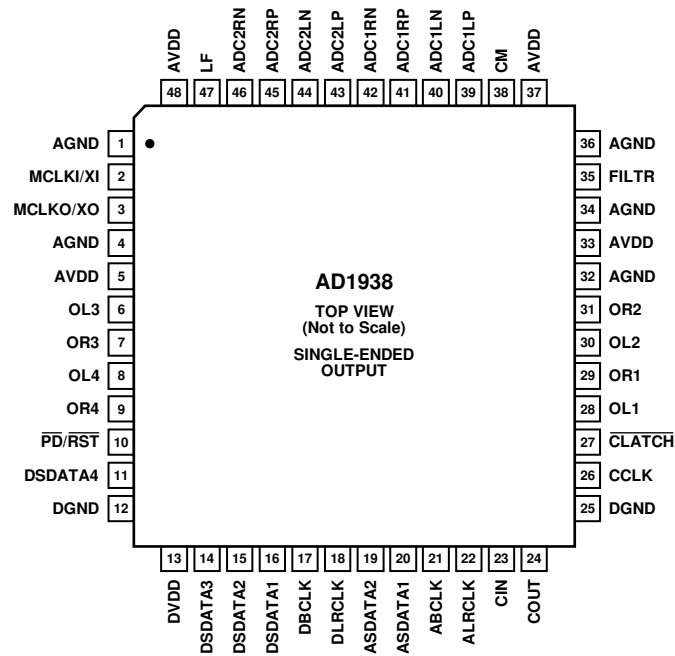

05582-002

Figure 2. Pin Configuration, 48-Lead LQFP

Table 10. Pin Function Descriptions

Pin No.	In/Out	Mnemonic	Description
1	I	AGND	Analog Ground.
2	I	MCLKI/XI	Master Clock Input/Crystal Oscillator Input.
3	O	MCKO/XO	Master Clock Output/Crystal Oscillator Output.
4	I	AGND	Analog Ground.
5	I	AVDD	Analog Power Supply. Connect to analog 3.3 V supply.
6	O	OL3	DAC 3 Left Output.
7	O	OR3	DAC 3 Right Output.
8	O	OL4	DAC 4 Left Output.
9	O	OR4	DAC 4 Right Output.
10	I	PD/RST	Power-Down Reset (Active Low).
11	I/O	DSDATA4	DAC Serial Input 4. Data input to DAC4 data in/TDM DAC2 data out (dual-line mode)/AUX DAC2 data out (to external DAC2).
12	I	DGND	Digital Ground.
13	I	DVDD	Digital Power Supply. Connect to digital 3.3 V supply.
14	I/O	DSDATA3	DAC Serial Input 3. Data input to DAC3 data in/TDM DAC2 data in (dual-line mode)/AUX ADC2 data in (from external ADC2).
15	I/O	DSDATA2	DAC Serial Input 2. Data input to DAC2 data in/TDM DAC data out/AUX ADC1 data in (from external ADC1).
16	I	DSDATA1	DAC Serial Data Input 1. Data input to DAC1 data in/TDM DAC data in/TDM data in.
17	I/O	DBCLK	Bit Clock for DACs.
18	I/O	DLRCLK	LR Clock for DACs.
19	I/O	ASDATA2	ADC Serial Data Output 2. Data output from ADC2/TDM ADC data in/AUX DAC1 data out (to external DAC1).
20	O	ASDATA1	ADC Serial Data Output 1. Data output from ADC1/TDM ADC data out/TDM data out.
21	I/O	ABCLK	Bit Clock for ADCs.
22	I/O	ALRCLK	LR Clock for ADCs.
23	I	CIN	Control Data Input (SPI).
24	I/O	COUT	Control Data Output (SPI).
25	I	DGND	Digital Ground.

Pin No.	In/Out	Mnemonic	Description
26	I	CCLK	Control Clock Input (SPI).
27	I	CLATCH	Latch Input for Control Data (SPI).
28	O	OL1	DAC 1 Left Output.
29	O	OR1	DAC 1 Right Output.
30	O	OL2	DAC 2 Left Output.
31	O	OR2	DAC 2 Right Output.
32	I	AGND	Analog Ground.
33	I	AVDD	Analog Power Supply. Connect to analog 3.3 V supply.
34	I	AGND	Analog Ground.
35	O	FILTR	Voltage Reference Filter Capacitor Connection. Bypass with 10 $\mu$ F  100 nF to AGND.
36	I	AGND	Analog Ground.
37	I	AVDD	Analog Power Supply. Connect to analog 3.3 V supply.
38	O	CM	Common-Mode Reference Filter Capacitor Connection. Bypass with 47 $\mu$ F  100 nF to AGND.
39	I	ADC1LP	ADC1 Left Positive Input.
40	I	ADC1LN	ADC1 Left Negative Input.
41	I	ADC1RP	ADC1 Right Positive Input.
42	I	ADC1RN	ADC1 Right Negative Input.
43	I	ADC2LP	ADC2 Left Positive Input.
44	I	ADC2LN	ADC2 Left Negative Input.
45	I	ADC2RP	ADC2 Right Positive Input.
46	I	ADC2RN	ADC2 Right Negative Input.
47	O	LF	PLL Loop Filter, Return to AVDD.
48	I	AVDD	Analog Power Supply. Connect to analog 3.3 V supply.

### TYPICAL PERFORMANCE CHARACTERISTICS

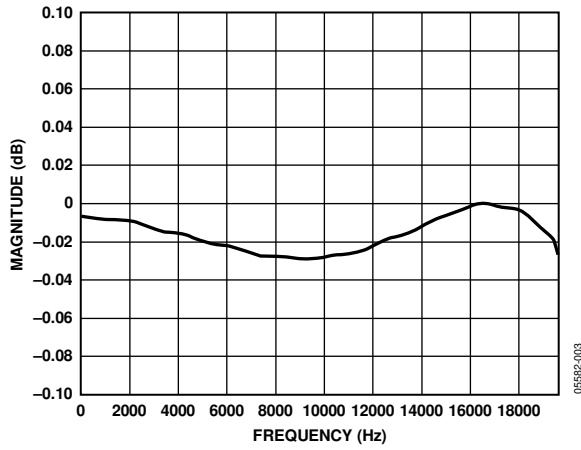

Figure 3. ADC Pass-Band Filter Response, 48 kHz

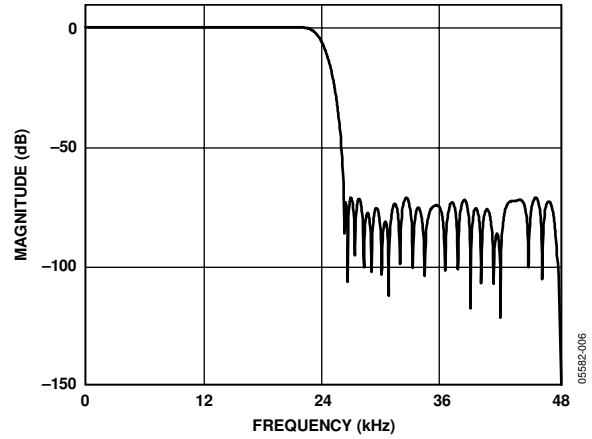

Figure 6. DAC Stop-Band Filter Response, 48 kHz

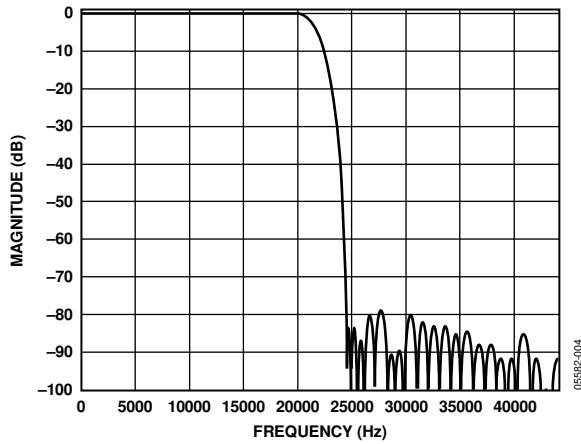

Figure 4. ADC Stop-Band Filter Response, 48 kHz

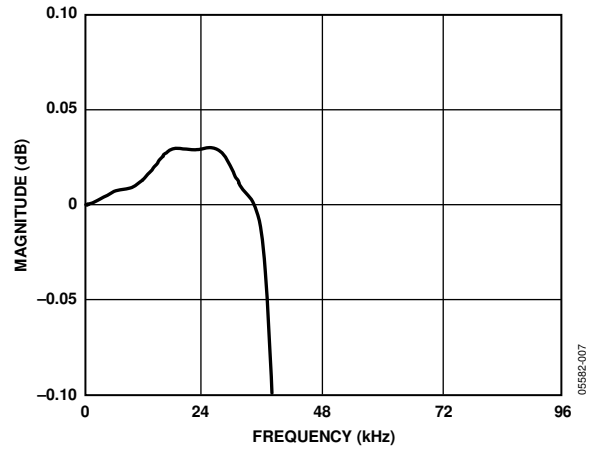

Figure 7. DAC Pass-Band Filter Response, 96 kHz

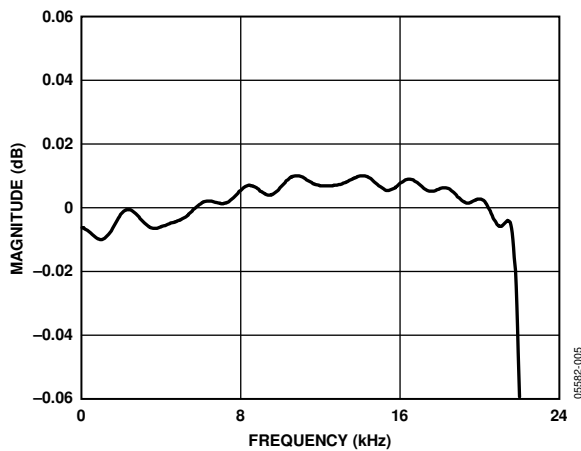

Figure 5. DAC Pass-Band Filter Response, 48 kHz

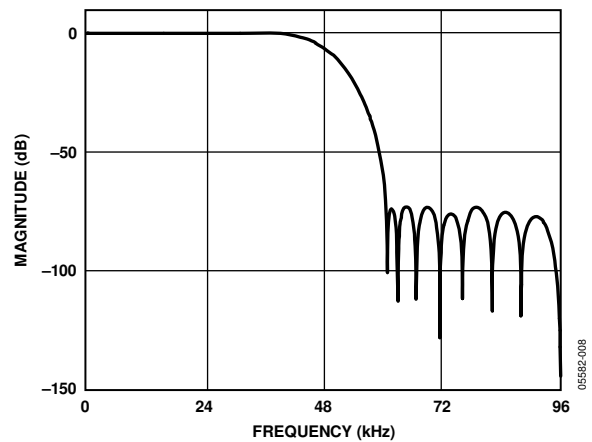

Figure 8. DAC Stop-Band Filter Response, 96 kHz

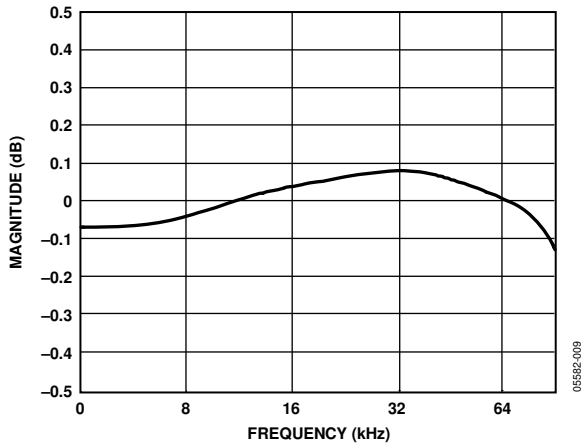

Figure 9. DAC Pass-Band Filter Response, 192 kHz

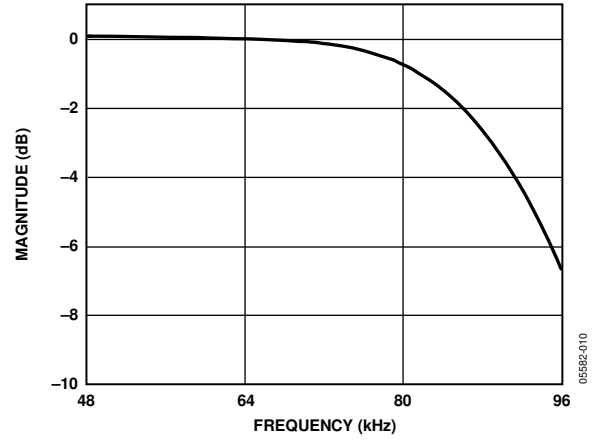

Figure 10. DAC Stop-Band Filter Response, 192 kHz

## THEORY OF OPERATION

### ANALOG-TO-DIGITAL CONVERTERS (ADCS)

There are four ADC channels in the [AD1938](#) configured as two stereo pairs with differential inputs. The ADCs can operate at a nominal sample rate of 48 kHz, 96 kHz, or 192 kHz. The ADCs include on-board digital antialiasing filters with 79 dB stop-band attenuation and linear phase response, operating at an oversampling ratio of 128 (48 kHz, 96 kHz, and 192 kHz modes). Digital outputs are supplied through two serial data output pins (one for each stereo pair) and a common frame clock (ALRCLK) and bit clock (ABCLK). Alternatively, one of the TDM modes can be used to access up to 16 channels on a single TDM data line.

The ADCs must be driven from a differential signal source for best performance. The input pins of the ADCs connect to internal switched capacitors. To isolate the external driving op amp from the glitches caused by the internal switched capacitors, each input pin should be isolated by using a series connected, external, 100  $\Omega$  resistor together with a 1 nF capacitor connected from each input to ground. This capacitor must be of high quality, for example, ceramic NPO or polypropylene film.

The differential inputs have a nominal common-mode voltage of 1.5 V. The voltage at the common-mode reference pin (CM) can be used to bias external op amps to buffer the input signals (see the Power Supply and Voltage Reference section). The inputs can also be ac-coupled and do not need an external dc bias to CM.

A digital high-pass filter can be switched in line with the ADCs under serial control to remove residual dc offsets. It has a 1.4 Hz, 6 dB per octave cutoff at a 48 kHz sample rate. The cutoff frequency scales directly with sample frequency.

### DIGITAL-TO-ANALOG CONVERTERS (DACs)

The [AD1938](#) DAC channels are arranged as single-ended, four stereo pairs giving eight analog outputs for minimum external components. The DACs include on-board digital reconstruction filters with 70 dB stop-band attenuation and linear phase response, operating at an oversampling ratio of 4 (48 kHz or 96 kHz modes) or 2 (192 kHz mode). Each channel has its own independently programmable attenuator, adjustable in 255 steps in increments of 0.375 dB. Digital inputs are supplied through four serial data input pins (one for each stereo pair), a common frame clock (DLRCLK), and a bit clock (DBCLK). Alternatively, one of the TDM modes can be used to access up to 16 channels on a single TDM data line.

Each output pin has a nominal common-mode dc level of 1.5 V and swings  $\pm 1.27$  V for a 0 dBFS digital input signal. A single op amp, third-order, external, low-pass filter is recommended to remove high frequency noise present on the output pins. The use of op amps with low slew rate or low bandwidth can cause high frequency noise and tones to fold down into the audio band; therefore, exercise care in selecting these components.

The voltage at CM, the common-mode reference pin, can be used to bias the external op amps that buffer the output signals (see the Power Supply and Voltage Reference section).

### CLOCK SIGNALS

The on-chip phase locked loop (PLL) can be selected to reference the input sample rate from either of the LRCLK pins or 256, 384, 512, or 768 times the sample rate, referenced to the 48 kHz mode from the MCLKI/XI pin. The default at power-up is  $256 \times f_s$  from the MCLKI/XI pin. In 96 kHz mode, the master clock frequency stays at the same absolute frequency; therefore, the actual multiplication rate is divided by 2. In 192 kHz mode, the actual multiplication rate is divided by 4. For example, if a device in the AD193x family is programmed in  $256 \times f_s$  mode, the frequency of the master clock input is  $256 \times 48$  kHz = 12.288 MHz. If the AD193x is then switched to 96 kHz operation (by writing to the SPI port), the frequency of the master clock should remain at 12.288 MHz, which becomes  $128 \times f_s$ . In 192 kHz mode, this becomes  $64 \times f_s$ .

The internal clock for the ADCs is  $256 \times f_s$  for all clock modes. The internal clock for the DACs varies by mode:  $512 \times f_s$  (48 kHz mode),  $256 \times f_s$  (96 kHz mode), or  $128 \times f_s$  (192 kHz mode). By default, the on-board PLL generates this internal master clock from an external clock. A direct  $512 \times f_s$  (referenced to 48 kHz mode) master clock can be used for either the ADCs or DACs if selected in the PLL and Clock Control 1 register.

Note that it is not possible to use a direct clock for the ADCs set to the 192 kHz mode. It is required that the on-chip PLL be used in this mode.

The PLL can be powered down in the PLL and Clock Control 0 register. To ensure reliable locking when changing PLL modes, or if the reference clock is unstable at power-on, power down the PLL and then power it back up when the reference clock stabilizes.

The internal master clock can be disabled in the PLL and Clock Control 0 register to reduce power dissipation when the [AD1938](#) is idle. The clock should be stable before it is enabled. Unless a standalone mode is selected (see the Serial Control Port section), the clock is disabled by reset and must be enabled by writing to the SPI port for normal operation.

To maintain the highest performance possible, limit the clock jitter of the internal master clock signal to less than a 300 ps rms time interval error (TIE). Even at these levels, extra noise or tones can appear in the DAC outputs if the jitter spectrum contains large spectral peaks. If the internal PLL is not used, it is best to use an independent crystal oscillator to generate the master clock. In addition, it is especially important that the clock signal not pass through an FPGA, CPLD, or other large digital chip (such as a DSP) before being applied to the [AD1938](#). In most cases, this induces clock jitter due to the sharing of common power and ground connections with other unrelated digital output signals. When the PLL is used, jitter in

the reference clock is attenuated above a certain frequency depending on the loop filter.

### RESET AND POWER-DOWN

The function of the  $\overline{\text{RST}}$  pin sets all the control registers to their default settings. To avoid pops, reset does not power down the analog outputs. After  $\overline{\text{RST}}$  is deasserted, and the PLL acquires lock condition, an initialization routine runs inside the AD1938. This initialization lasts for approximately 256 master clock cycles.

The power-down bits in the PLL and Clock Control 0, DAC Control 1, and ADC Control 1 registers power down the respective sections. All other register settings are retained. To guarantee proper start up, the  $\overline{\text{RST}}$  pin should be pulled low by an external resistor.

### SERIAL CONTROL PORT

The AD1938 has an SPI control port that permits programming and reading back of the internal control registers for the ADCs, DACs, and clock system. There is also a standalone mode available for operation without serial control that is configured

at reset using the serial control pins. All registers are set to default, except the internal master clock enable which is set to 1, and ADC BCLK and LRCLK master/slave is set by the COUT pin. Refer to Table 11 for details. Standalone mode only supports stereo mode with an I<sup>2</sup>S data format and 256 f<sub>s</sub> master clock rate. It is recommended to use a weak pull-up resistor on  $\overline{\text{CLATCH}}$  in applications that have a microcontroller. This pull-up resistor ensures that the AD1938 recognizes the presence of a microcontroller.

The SPI control port of the AD1938 is a 4-wire serial control port. The format is similar to the Motorola SPI format except the input data-word is 24 bits wide. The serial bit clock and latch can be completely asynchronous to the sample rate of the ADCs and DACs. Figure 11 shows the format of the SPI signal. The first byte is a global address with a read/write bit. For the AD1938, the address is 0x04, shifted left one bit due to the  $\overline{\text{R/W}}$  bit. The second byte is the AD1938 register address and the third byte is the data.

Table 11. Standalone Mode Selection

ADC Clocks	CIN	COUT	CCLK	CLATCH
Slave	0	0	0	0
Master	0	1	0	0

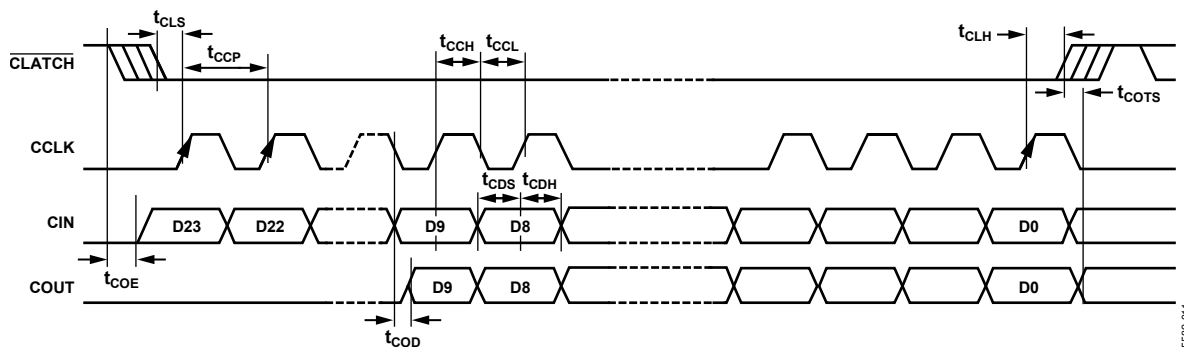

Figure 11. Format of SPI Signal

05592-011



**POWER SUPPLY AND VOLTAGE REFERENCE**

The AD1938 is designed for 3.3 V supplies. Separate power supply pins are provided for the analog and digital sections. These pins should be bypassed with 100 nF ceramic chip capacitors, as close to the pins as possible, to minimize noise pickup. A bulk aluminum electrolytic capacitor of at least 22  $\mu$ F should also be provided on the same PCB as the codec. For critical applications, improved performance is obtained with separate supplies for the analog and digital sections. If this is not possible, it is recommended that the analog and digital supplies be isolated by means of a ferrite bead in series with each supply. It is important that the analog supply be as clean as possible.

All digital inputs are compatible with TTL and CMOS levels. All outputs are driven from the 3.3 V DVDD supply and are compatible with TTL and 3.3 V CMOS levels.

The ADC and DAC internal voltage reference (VREF) is brought out on FILTR and should be bypassed as close as possible to the chip, with a parallel combination of 10  $\mu$ F and 100 nF. Any external current drawn should be limited to less than 50  $\mu$ A.

The internal reference can be disabled in the PLL and Clock Control 1 register, and FILTR can be driven from an external source. This configuration can be used to scale the DAC output to the clipping level of a power amplifier based on its power supply voltage. The ADC input gain varies by the inverse ratio. The total gain from ADC input to DAC output remains constant.

The CM pin is the internal common-mode reference. It should be bypassed as close as possible to the chip, with a parallel combination of 47  $\mu$ F and 100 nF. This voltage can be used to bias external op amps to the common-mode voltage of the input and output signal pins. The output current should be limited to less than 0.5 mA source and 2 mA sink.

**SERIAL DATA PORTS—DATA FORMAT**

The eight DAC channels use a common serial bit clock (DBCLK) and a common left-right framing clock (DLRCLK) in the serial data port. The four ADC channels use a common serial bit clock (ABCLK) and left-right framing clock (ALRCLK) in the serial data port. The clock signals are all synchronous with the sample rate. The normal stereo serial modes are shown in Figure 23.

The ADC and DAC serial data modes default to I<sup>2</sup>S. The ports can also be programmed for left-justified, right-justified, and TDM modes. The word width is 24 bits by default and can be programmed for 16 or 20 bits. The DAC serial formats are programmable according to the DAC Control 0 register. The polarity of the DBCLK and DLRCLK is programmable according to DAC Control 1 register. The ADC serial formats and serial clock polarity are programmable according to ADC Control 1 register. Both DAC and ADC serial ports are programmable to become the bus masters according to DAC Control 1 register

and ADC Control 2 register. By default, both ADC and DAC serial ports are in the slave mode.

**TIME-DIVISION MULTIPLEXED (TDM) MODES**

The AD1938 serial ports also have several different TDM serial data modes. The first and most commonly used configurations are shown in Figure 12 and Figure 13. In Figure 12, the ADC serial port outputs one data stream consisting of four on-chip ADCs followed by four unused slots. In Figure 13, the eight on-chip DAC data slots are packed into one TDM stream. In this mode, both DBCLK and ABCLK are 256 f<sub>s</sub>.

The I/O pins of the serial ports are defined according to the serial mode selected. For a detailed description of the function of each pin in TDM and auxiliary modes, see Table 12.

The AD1938 allows systems with more than eight DAC channels to be easily configured by the use of an auxiliary serial data port. The DAC TDM-AUX mode is shown in Figure 14. In this mode, the AUX channels are the last four slots of the TDM data stream. These slots are extracted and output to the AUX serial port. It should be noted that due to the high DBCLK frequency, this mode is available only in the 48 kHz/44.1 kHz/32 kHz sample rate.

The AD1938 also allows system configurations with more than four ADC channels as shown in Figure 15 and Figure 16 that show using 8 ADCs and 16 ADCs, respectively. Again, due to the high ABCLK frequency, this mode is available only in the 48 kHz/44.1 kHz/32 kHz sample rate.

Combining the AUX ADC and DAC modes results in a system configuration of 8 ADCs and 12 DACs. The system, then, consists of two external stereo ADCs, two external stereo DACs, and one AD1938. This mode is shown in Figure 17 (combined AUX ADC and DAC modes).

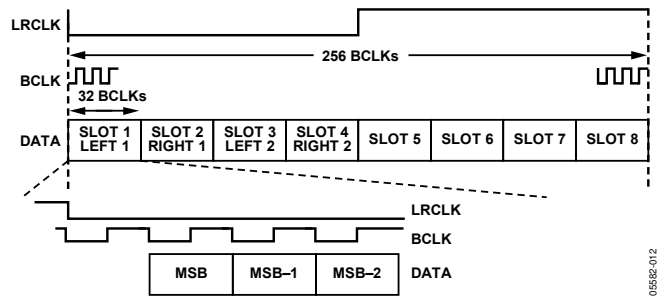

Figure 12. ADC TDM (8-Channel I<sup>2</sup>S Mode)

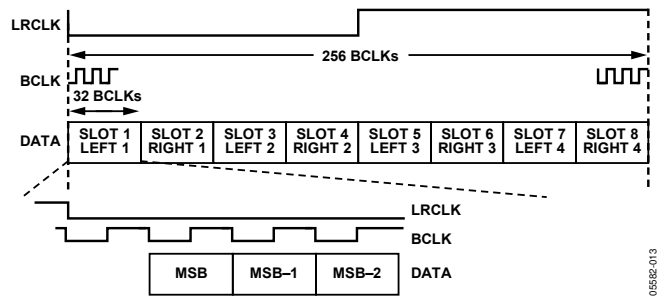

Figure 13. DAC TDM (8-Channel I<sup>2</sup>S Mode)

Table 12. Pin Function Changes in TDM-AUX Modes

Mnemonic	Stereo Modes	TDM Modes	AUX Modes
ASDATA1	ADC1 Data Out	ADC TDM Data Out	TDM Data Out
ASDATA2	ADC2 Data Out	ADC TDM Data In	AUX Data Out 1 (to Ext. DAC 1)
DSDATA1	DAC1 Data In	DAC TDM Data In	TDM Data In
DSDATA2	DAC2 Data In	DAC TDM Data Out	AUX Data In 1 (from Ext. ADC 1)
DSDATA3	DAC3 Data In	DAC TDM Data In 2 (Dual-Line Mode)	AUX Data In 2 (from Ext. ADC 2)
DSDATA4	DAC4 Data In	DAC TDM Data Out 2 (Dual-Line Mode)	AUX Data Out 2 (to Ext. DAC 2)
ALRCLK	ADC LRCLK In/ADC LRCLK Out	ADC TDM Frame Sync In/DC TDM Frame Sync Out	TDM Frame Sync In/TDM Frame Sync Out
ABCLK	ADC BCLK In/ADC BCLK Out	ADC TDM BCLK In/ADC TDM BCLK Out	TDM BCLK In/TDM BCLK Out
DLRCLK	DAC LRCLK In/DAC LRCLK Out	DAC TDM Frame Sync In/DAC TDM Frame Sync Out	AUX LRCLK In/AUX LRCLK Out
DBCLK	DAC BCLK In/DAC BCLK Out	DAC TDM BCLK In/DAC TDM BCLK Out	AUX BCLK In/AUX BCLK Out

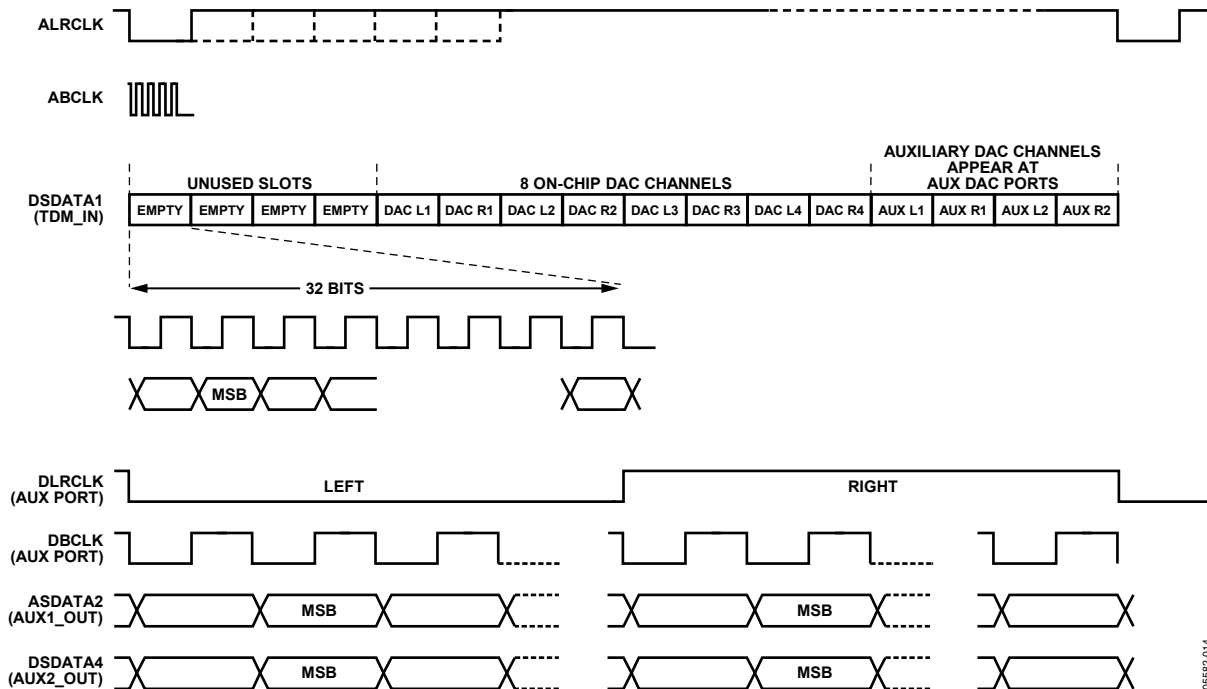

Figure 14. 16-Channel AUX DAC Mode

05582-014

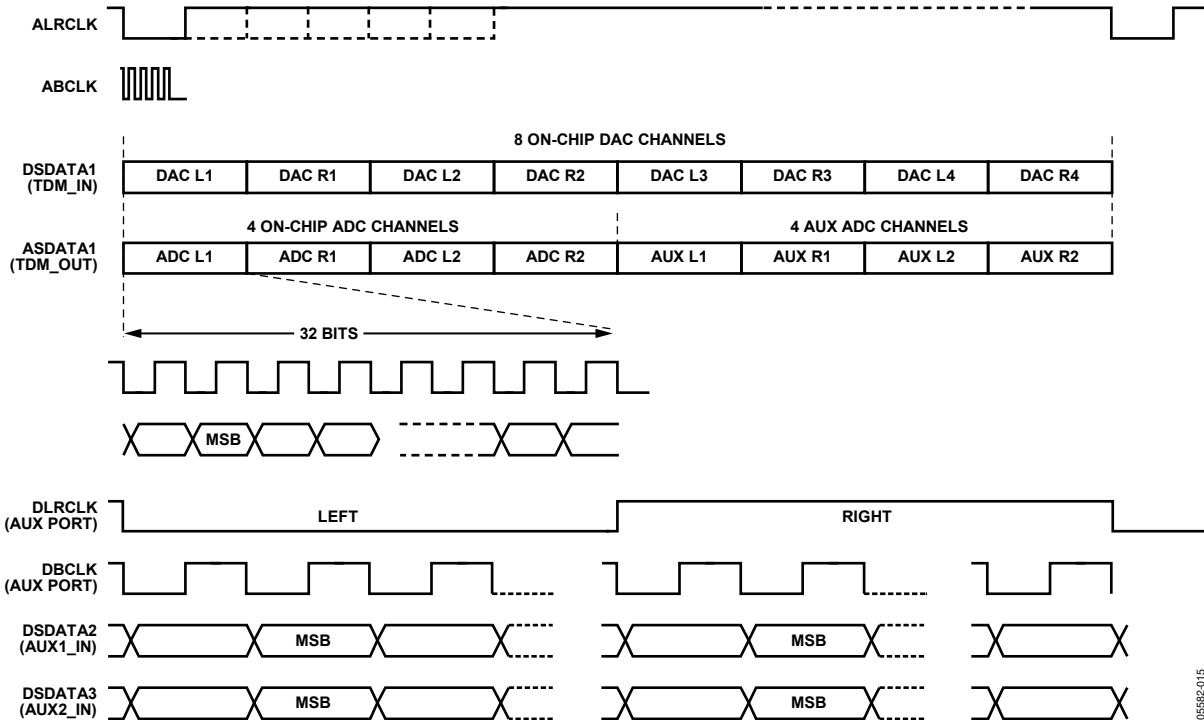

Figure 15. 8-Channel AUX ADC Mode

055862-015

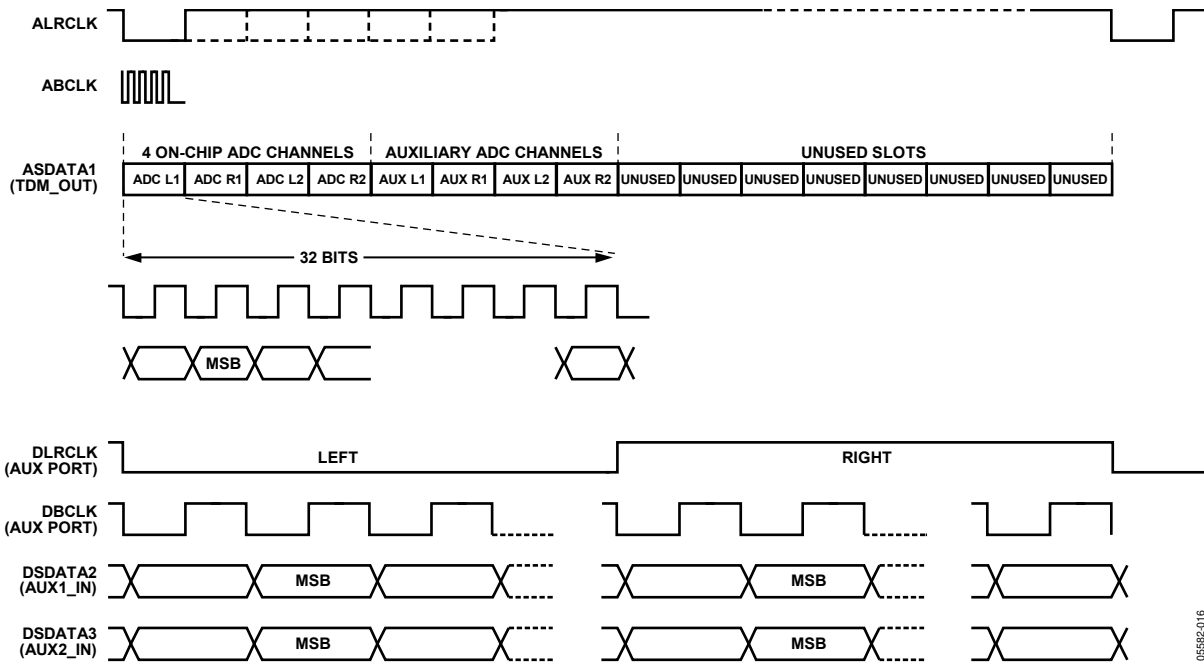

Figure 16. 16-Channel AUX ADC Mode

055862-016

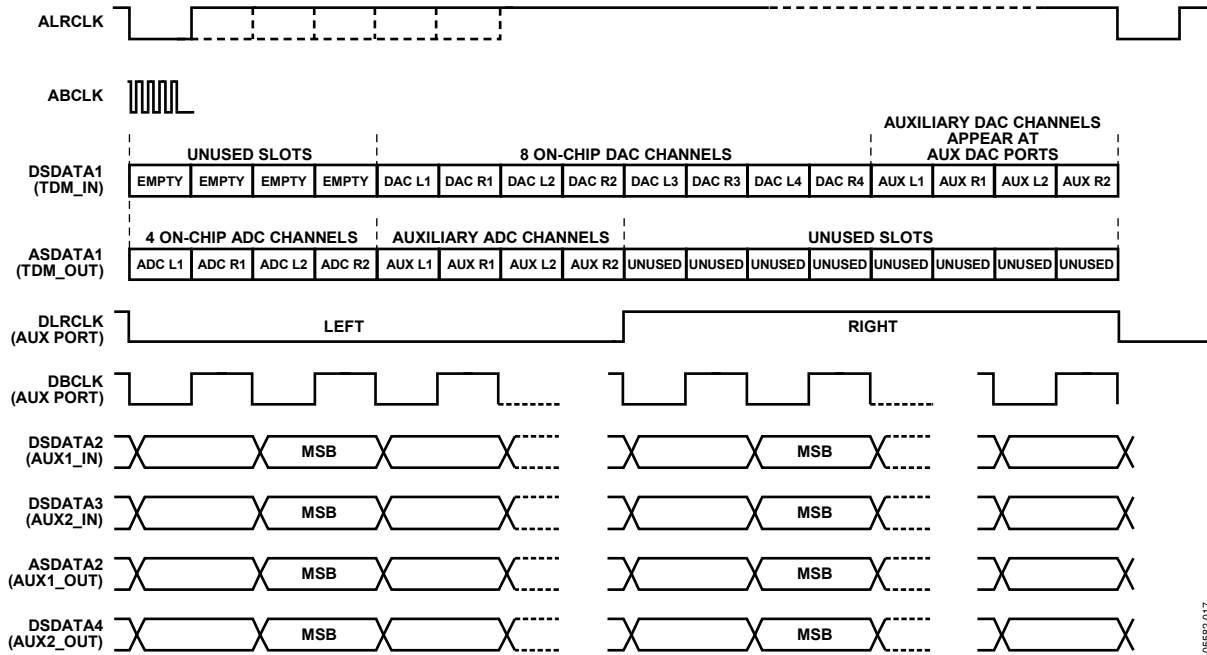

Figure 17. Combined AUX DAC and ADC Mode

05582-017

**DAISY-CHAIN MODE**

The AD1938 allows a daisy-chain configuration to expand the system to 8 ADCs and 16 DACs (see Figure 18). In this mode, the DBCLK frequency is 512 fs. The first eight slots of the DAC TDM data stream belong to the first AD1938 in the chain and the last eight slots belong to the second AD1938. The second AD1938 is the device attached to the DSP TDM port.

To accommodate 16 channels at a 96 kHz sample rate, the AD1938 can be configured into a dual-line TDM mode as shown in Figure 19. This mode allows a slower DBCLK than normally required by the one-line TDM mode.

Again, the first four channels of each TDM input belong to the first AD1938 in the chain and the last four channels belong to the second AD1938.

The dual-line TDM mode can also be used to send data at a 192 kHz sample rate into the AD1938 as shown in Figure 20.

There are two configurations for the ADC port to work in daisy-chain mode. The first one is with an ABCLK at 256 fs shown in Figure 21. The second configuration is shown in Figure 22. Note that in the 512 fs ABCLK mode, the ADC channels occupy the first eight slots; the second eight slots are empty. The TDM\_IN of the first AD1938 must be grounded in all modes of operation.

The I/O pins of the serial ports are defined according to the serial mode selected. See Table 13 for a detailed description of the function of each pin. See Figure 26 for a typical AD1938 configuration with two external stereo DACs and two external stereo ADCs.

Figure 23 through Figure 25 show the serial mode formats. For maximum flexibility, the polarity of LRCLK and BCLK are programmable. In these figures, all of the clocks are shown with their normal polarity. The default mode is I<sup>2</sup>S.

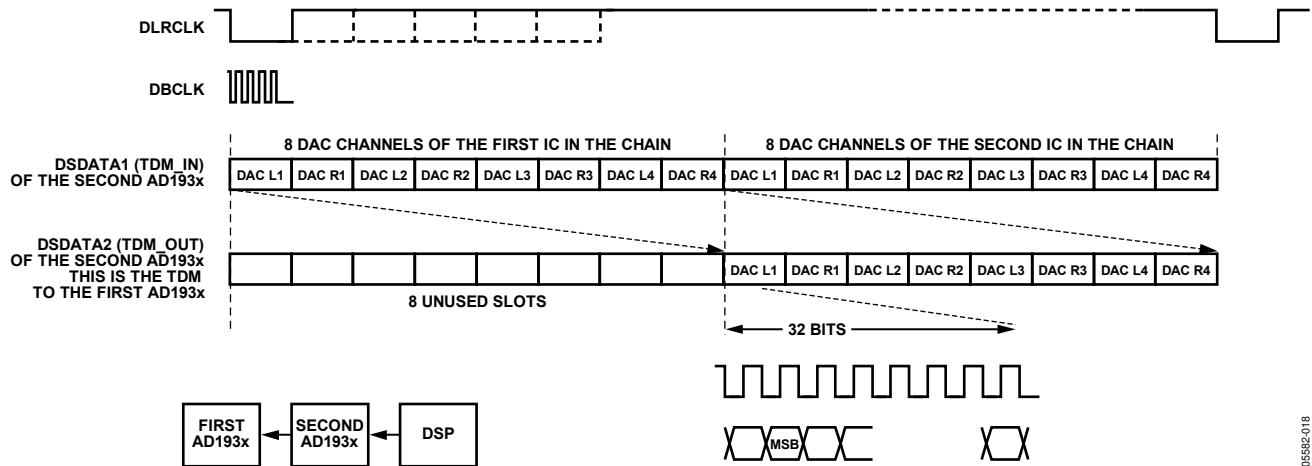

Figure 18. Single-Line DAC TDM Daisy-Chain Mode (Applicable to 48 kHz Sample Rate, 16-Channel, Two-AD1938 Daisy Chain)

05582-018

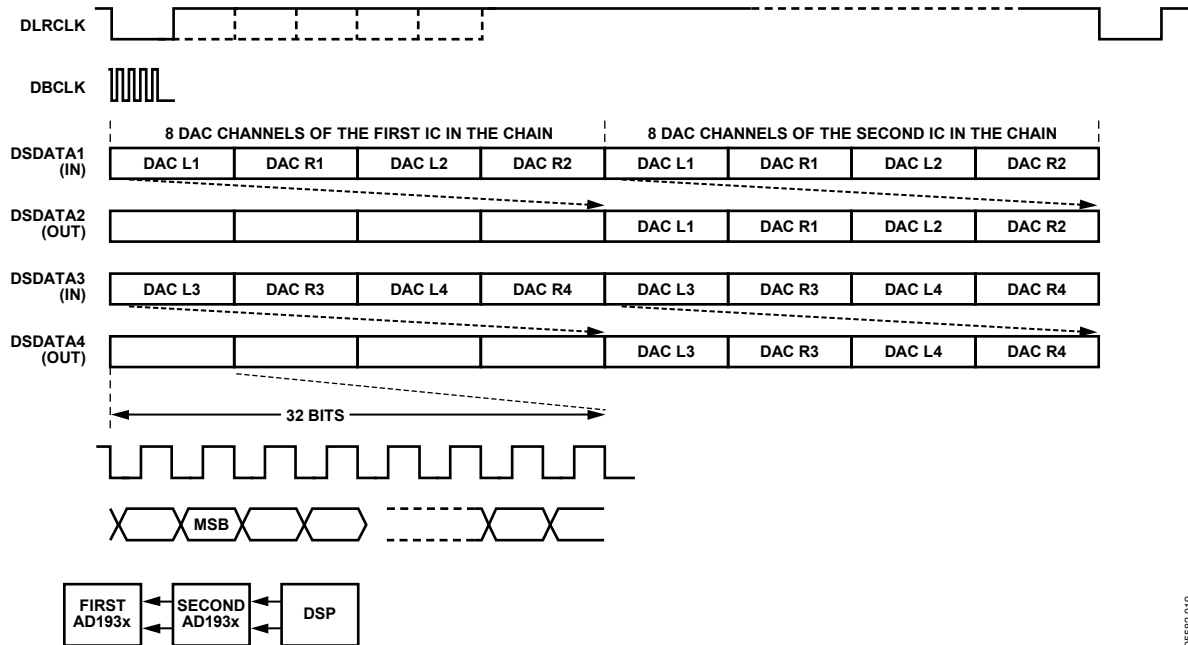

Figure 19. Dual-Line DAC TDM Mode (Applicable to 96 kHz Sample Rate, 16-Channel, Two-AD1938 Daisy Chain); DSDATA3 and DSDATA4 Are the Daisy Chain

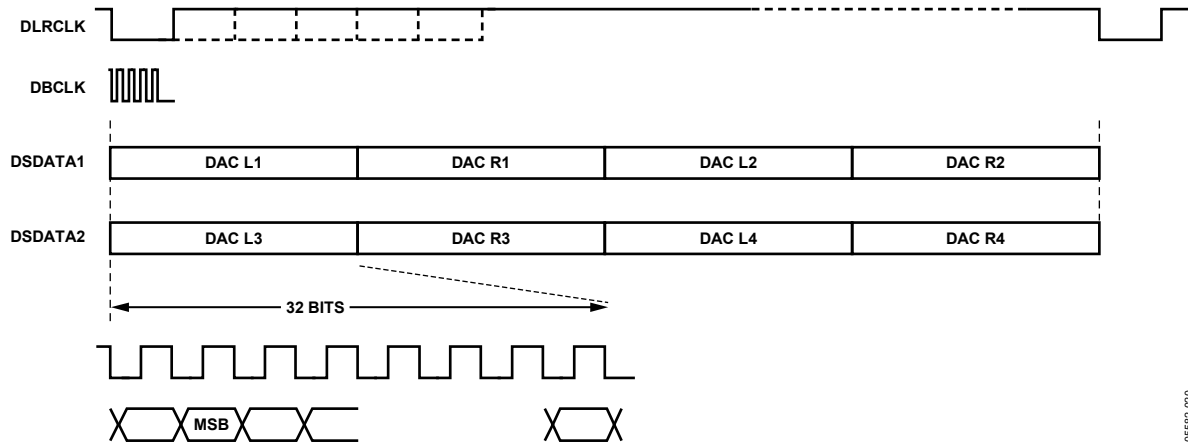

Figure 20. Dual-Line DAC TDM Mode (Applicable to 192 kHz Sample Rate, 8-Channel Mode)

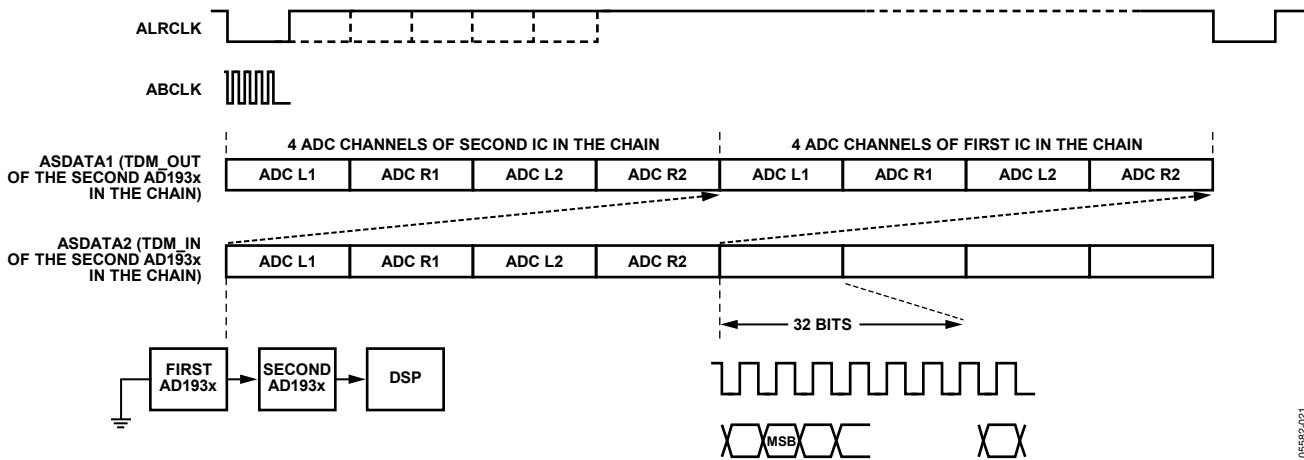

Figure 21. ADC TDM Daisy-Chain Mode (256 fs BCLK, Two-AD193x Daisy Chain)

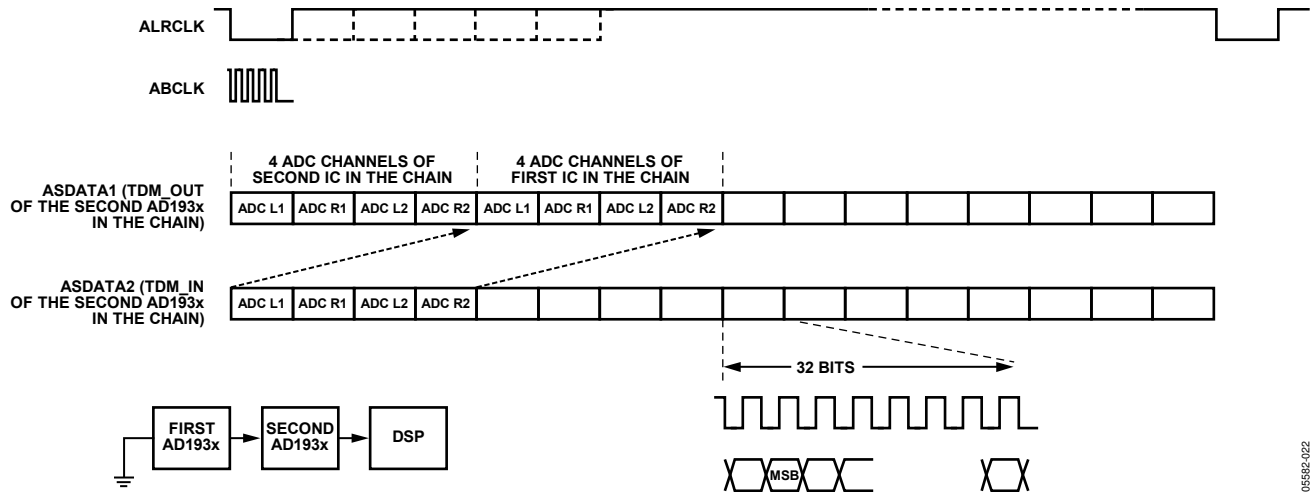
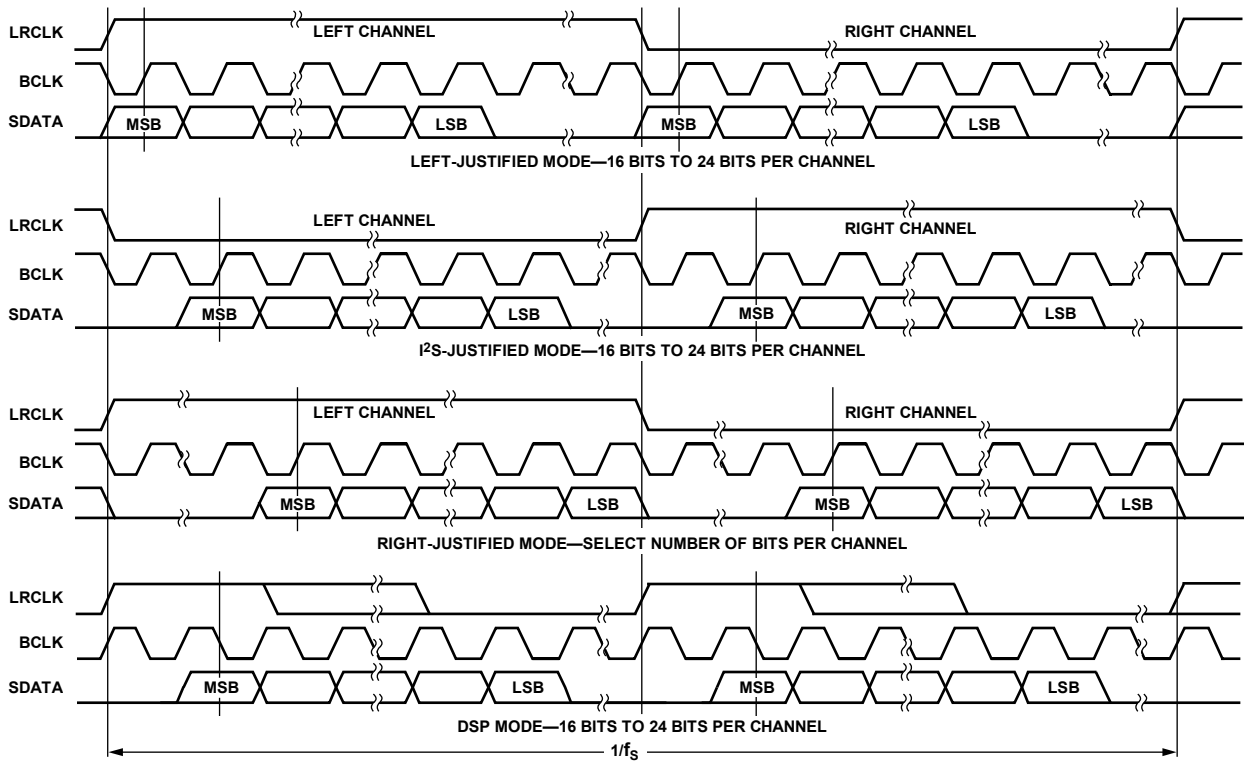

Figure 22. ADC TDM Daisy-Chain Mode (512  $f_s$  BCLK, Two-AD193x Daisy Chain)



NOTES

1. DSP MODE DOES NOT IDENTIFY CHANNEL.
2. LRCLK NORMALLY OPERATES AT  $f_s$  EXCEPT FOR DSP MODE WHICH IS  $2 \times f_s$ .
3. BCLK FREQUENCY IS NORMALLY  $64 \times$  LRCLK BUT MAY BE OPERATED IN BURST MODE.

Figure 23. Stereo Serial Modes

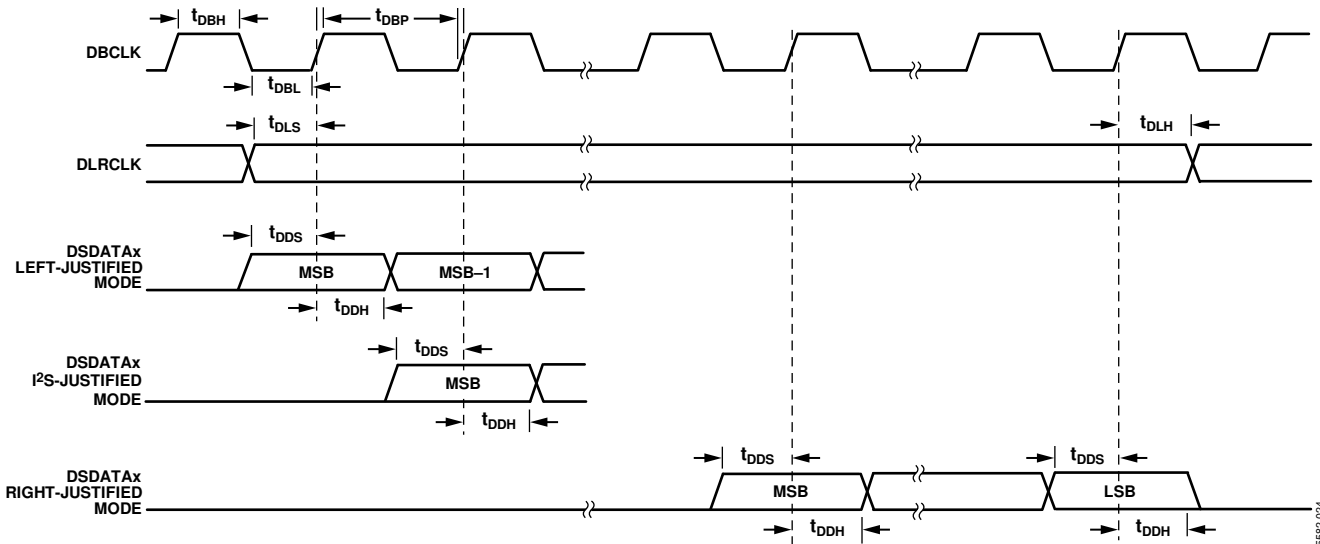

Figure 24. DAC Serial Timing

05582-024

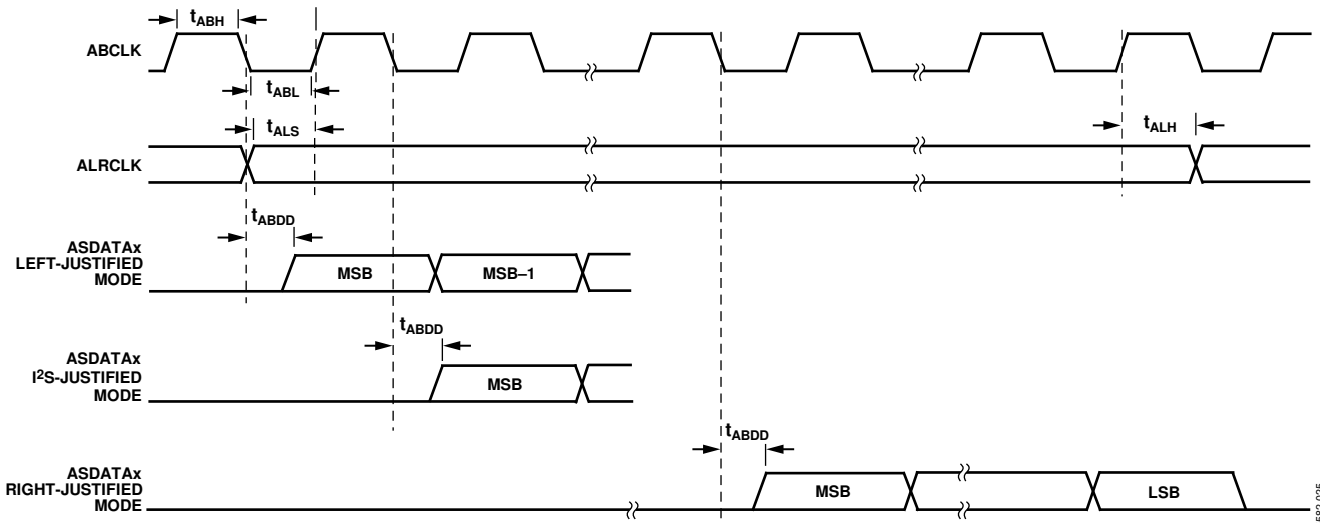

Figure 25. ADC Serial Timing

05582-025



Table 13. Pin Function Changes in TDM and AUX Modes (Replication of Table 12)

Mnemonic	Stereo Modes	TDM Modes	AUX Modes
ASDATA1	ADC1 Data Out	ADC TDM Data Out	TDM Data Out
ASDATA2	ADC2 Data Out	ADC TDM Data In	AUX Data Out 1 (to Ext. DAC 1)
DSDATA1	DAC1 Data In	DAC TDM Data In	TDM Data In
DSDATA2	DAC2 Data In	DAC TDM Data Out	AUX Data In 1 (from Ext. ADC 1)
DSDATA3	DAC3 Data In	DAC TDM Data In 2 (Dual-Line Mode)	AUX Data In 2 (from Ext. ADC 2)
DSDATA4	DAC4 Data In	DAC TDM Data Out 2 (Dual-Line Mode)	AUX Data Out 2 (to Ext. DAC 2)
ALRCLK	ADC LRCLK In/ADC LRCLK Out	ADC TDM Frame Sync In/DC TDM Frame Sync Out	TDM Frame Sync In/TDM Frame Sync Out
ABCLK	ADC BCLK In/ADC BCLK Out	ADC TDM BCLK In/ADC TDM BCLK Out	TDM BCLK In/TDM BCLK Out
DLRCLK	DAC LRCLK In/DAC LRCLK Out	DAC TDM Frame Sync In/DAC TDM Frame Sync Out	AUX LRCLK In/AUX LRCLK Out
DBCLK	DAC BCLK In/DAC BCLK Out	DAC TDM BCLK In/DAC TDM BCLK Out	AUX BCLK In/AUX BCLK Out

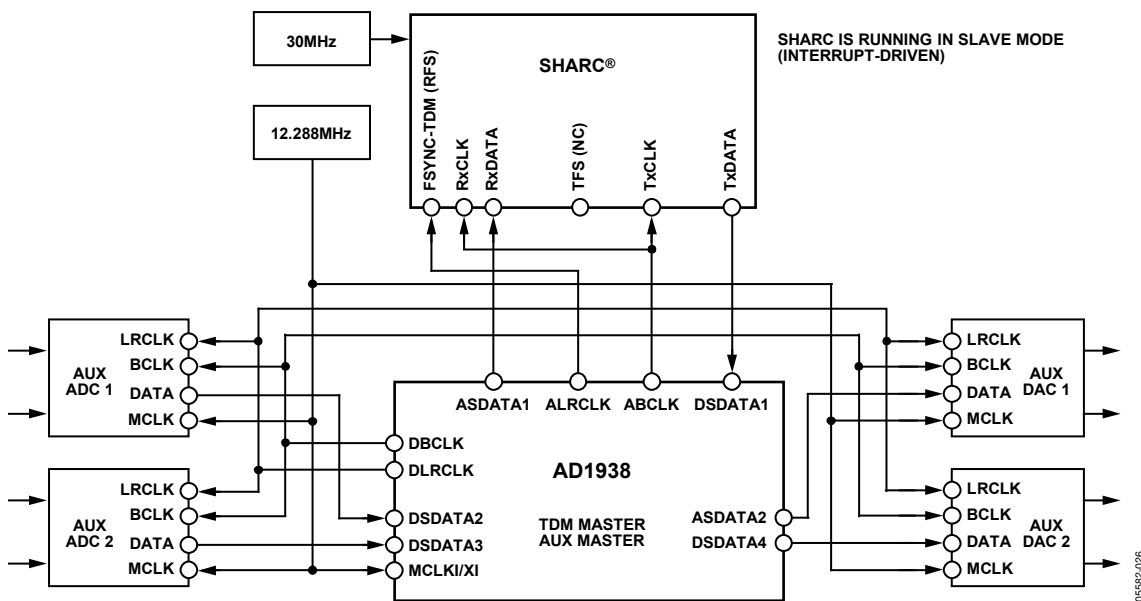

Figure 26. Example of AUX Mode Connection to SHARC (AD1938 as TDM Master/AUX Master Shown)

## CONTROL REGISTERS

### DEFINITIONS

The global address for the AD1938 is 0x04, shifted left one bit due to the  $\overline{R/W}$  bit. All registers are reset to 0, except for the DAC volume registers that are set to full volume.

Note that the first setting in each control register parameter is the default setting.

**Table 14. Register Format**

	Global Address	R/W	Register Address	Data
Bit	23:17	16	15:8	7:0

**Table 15. Register Addresses and Functions**

Address	Function
0	PLL and Clock Control 0
1	PLL and Clock Control 1
2	DAC Control 0
3	DAC Control 1
4	DAC Control 2
5	DAC individual channel mutes
6	DAC L1 volume control
7	DAC R1 volume control
8	DAC L2 volume control
9	DAC R2 volume control
10	DAC L3 volume control
11	DAC R3 volume control
12	DAC L4 volume control
13	DAC R4 volume control
14	ADC Control 0
15	ADC Control 1
16	ADC Control 2

### PLL AND CLOCK CONTROL REGISTERS

**Table 16. PLL and Clock Control Register 0**

Bit	Value	Function	Description
0	0	Normal operation	PLL power-down
	1	Power-down	
2:1	00	INPUT 256 ( $\times 44.1$ kHz or 48 kHz)	MCLKI/XI pin functionality (PLL active), master clock rate setting
	01	INPUT 384 ( $\times 44.1$ kHz or 48 kHz)	
	10	INPUT 512 ( $\times 44.1$ kHz or 48 kHz)	
	11	INPUT 768 ( $\times 44.1$ kHz or 48 kHz)	
4:3	00	XTAL oscillator enabled	MCLKO/XO pin, master clock rate setting
	01	$256 \times f_s$ VCO output	
	10	$512 \times f_s$ VCO output	
	11	Off	
6:5	00	MCLKI/XI	PLL input
	01	DLRCLK	
	10	ALRCLK	
	11	Reserved	
7	0	Disable: ADC and DAC idle	Internal master clock enable
	1	Enable: ADC and DAC active	