



Chipsmall Limited consists of a professional team with an average of over 10 year of expertise in the distribution of electronic components. Based in Hongkong, we have already established firm and mutual-benefit business relationships with customers from,Europe,America and south Asia,supplying obsolete and hard-to-find components to meet their specific needs.

With the principle of "Quality Parts,Customers Priority,Honest Operation,and Considerate Service",our business mainly focus on the distribution of electronic components. Line cards we deal with include Microchip,ALPS,ROHM,Xilinx,Pulse,ON,Everlight and Freescale. Main products comprise IC,Modules,Potentiometer,IC Socket,Relay,Connector.Our parts cover such applications as commercial,industrial, and automotives areas.

We are looking forward to setting up business relationship with you and hope to provide you with the best service and solution. Let us make a better world for our industry!



Contact us

Tel: +86-755-8981 8866 Fax: +86-755-8427 6832

Email & Skype: info@chipsmall.com Web: www.chipsmall.com

Address: A1208, Overseas Decoration Building, #122 Zhenhua RD., Futian, Shenzhen, China



FEATURES

Four 8-Bit DACs with Output Amplifiers
Skinny 20-Lead DIP, SOIC, SSOP, and PLCC Packages
Microprocessor-Compatible
TTL/CMOS-Compatible
No User Trims
Extended Temperature Range Operation
Single Supply Operation Possible

APPLICATIONS

Process Control
Automatic Test Equipment
Automatic Calibration of Large System Parameters,
e.g., Gain/Offset

FUNCTIONAL BLOCK DIAGRAM

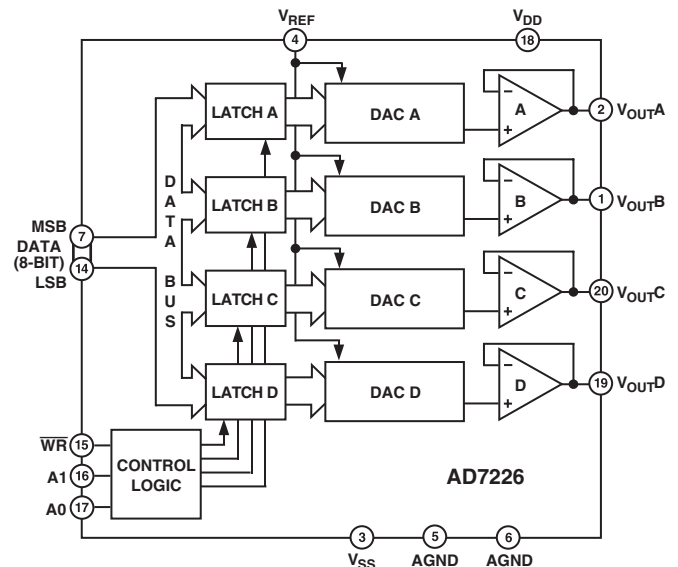

GENERAL DESCRIPTION

The AD7226 contains four 8-bit voltage-output digital-to-analog converters, with output buffer amplifiers and interface logic on a single monolithic chip. No external trims are required to achieve full specified performance for the part.

Separate on-chip latches are provided for each of the four D/A converters. Data is transferred into one of these data latches through a common 8-bit TTL/CMOS (5 V) compatible input port. Control inputs A0 and A1 determine which DAC is loaded when \overline{WR} goes low. The control logic is speed-compatible with most 8-bit microprocessors.

Each D/A converter includes an output buffer amplifier capable of driving up to 5 mA of output current. The amplifiers' offsets are laser-trimmed during manufacture, thereby eliminating any requirement for offset nulling.

Specified performance is guaranteed for input reference voltages from 2 V to 12.5 V with dual supplies. The part is also specified for single supply operation at a reference of 10 V.

The AD7226 is fabricated in an all ion-implanted high speed Linear Compatible CMOS (LC²MOS) process, which has been specifically developed to allow high speed digital logic circuits and precision analog circuits to be integrated on the same chip.

REV. D

Information furnished by Analog Devices is believed to be accurate and reliable. However, no responsibility is assumed by Analog Devices for its use, nor for any infringements of patents or other rights of third parties that may result from its use. No license is granted by implication or otherwise under any patent or patent rights of Analog Devices. Trademarks and registered trademarks are the property of their respective companies.

PRODUCT HIGHLIGHTS

- 1. DAC-to-DAC Matching**
Since all four DACs are fabricated on the same chip at the same time, precise matching and tracking between the DACs is inherent.
- 2. Single-Supply Operation**
The voltage mode configuration of the DACs allows the AD7226 to be operated from a single power supply rail.
- 3. Microprocessor Compatibility**
The AD7226 has a common 8-bit data bus with individual DAC latches, providing a versatile control architecture for simple interface to microprocessors. All latch enable signals are level triggered.
- 4. Small Size**
Combining four DACs and four op amps plus interface logic into a 20-pin package allows a dramatic reduction in board space requirements and offers increased reliability in systems using multiple converters. Its pinout is aimed at optimizing board layout with all the analog inputs and outputs at one end of the package and all the digital inputs at the other.

AD7226* PRODUCT PAGE QUICK LINKS

Last Content Update: 02/23/2017

COMPARABLE PARTS

View a parametric search of comparable parts.

DOCUMENTATION

Application Notes

- AN-317: Circuit Applications of the AD7226 Quad CMOS DAC
- AN-321: 3-Phase Sine Wave Generation Using the AD7226 Quad DAC

Data Sheet

- AD7226: Military Data Sheet
- AD7226: LC²MOS Quad 8-Bit D/A Converter Data Sheet

REFERENCE MATERIALS

Solutions Bulletins & Brochures

- Digital to Analog Converters ICs Solutions Bulletin

DESIGN RESOURCES

- AD7226 Material Declaration
- PCN-PDN Information
- Quality And Reliability
- Symbols and Footprints

DISCUSSIONS

View all AD7226 EngineerZone Discussions.

SAMPLE AND BUY

Visit the product page to see pricing options.

TECHNICAL SUPPORT

Submit a technical question or find your regional support number.

DOCUMENT FEEDBACK

Submit feedback for this data sheet.

AD7226—SPECIFICATIONS ($V_{DD} = 11.4\text{ V to }16.5\text{ V}$, $V_{SS} = -5\text{ V} \pm 10\%$, $AGND = DGND = 0\text{ V}$; $V_{REF} = +2\text{ V to } (V_{DD} - 4\text{ V})^1$, unless otherwise noted. All Specifications T_{MIN} to T_{MAX} unless otherwise noted.)

DUAL SUPPLY

Parameter	K, B Versions ²	Unit	Conditions/Comments
STATIC PERFORMANCE			
Resolution	8	Bits	$V_{DD} = 15\text{ V} \pm 5\%$, $V_{REF} = 10\text{ V}$
Total Unadjusted Error	± 1	LSB max	
Relative Accuracy	± 0.5	LSB max	Guaranteed Monotonic
Differential Nonlinearity	± 1	LSB max	
Full-Scale Error	± 0.5	LSB max	$V_{DD} = 14\text{ V to }16.5\text{ V}$, $V_{REF} = +10\text{ V}$
Full-Scale Temperature Coefficient	± 20	ppm/ $^{\circ}\text{C}$ typ	
Zero Code Error	± 20	mV max	
Zero Code Error Temperature Coefficient	± 50	$\mu\text{V}/^{\circ}\text{C}$ typ	
REFERENCE INPUT			
Voltage Range	2 to $(V_{DD} - 4)$	V min to V max	Occurs when each DAC is loaded with all 0s. Occurs when each DAC is loaded with all 1s.
Input Resistance	2	k Ω min	
Input Capacitance ³	50 200	pF min pF max	
DIGITAL INPUTS			
Input High Voltage, V_{INH}	2.4	V min	$V_{IN} = 0\text{ V or }V_{DD}$
Input Low Voltage, V_{INL}	0.8	V max	
Input Leakage Current	± 1	μA max	
Input Capacitance	8	pF max	
Input Coding	Binary		
DYNAMIC PERFORMANCE			
Voltage Output Slew Rate ⁴	2.5	V/ μs min	$V_{REF} = 10\text{ V}$; Settling Time to $\pm 1/2$ LSB
Voltage Output Settling Time ⁴	4	μs max	
Digital Crosstalk	10	nV secs typ	$V_{OUT} = 10\text{ V}$
Minimum Load Resistance	2	k Ω min	
POWER SUPPLIES			
V_{DD} Range	11.4/16.5	V min/V max	For Specified Performance Outputs Unloaded; $V_{IN} = V_{INL}$ or V_{INH} Outputs Unloaded; $V_{IN} = V_{INL}$ or V_{INH}
I_{DD}	13	mA max	
I_{SS}	11	mA max	
SWITCHING CHARACTERISTICS^{4, 5}			
Address to Write Setup Time, t_{AS}	0	ns min	
Address to Write Hold Time, t_{AH}	0	ns min	
Data Valid to Write Setup Time, t_{DS}	50	ns min	
Data Valid to Write Hold Time, t_{DH}	0	ns min	
Write Pulsewidth, t_{WR}	50	ns min	

NOTES

¹Maximum possible reference voltage.

²Temperature ranges are as follows:

K Version: $-40^{\circ}\text{C to }+85^{\circ}\text{C}$

B Version: $-40^{\circ}\text{C to }+85^{\circ}\text{C}$

³Guaranteed by design. Not production tested.

⁴Sample Tested at 25°C to ensure compliance.

⁵Switching Characteristics apply for single and dual supply operation.

Specifications subject to change without notice.

SINGLE SUPPLY

($V_{DD} = 15\text{ V} \pm 5\%$, $V_{SS} = \text{AGND} = \text{DGND} = 0\text{ V}$; $V_{REF} = 10\text{ V}^1$ unless otherwise noted.
All specifications T_{MIN} to T_{MAX} unless otherwise noted.)

Parameter	K, B Versions ²	Unit	Conditions/Comments
STATIC PERFORMANCE			
Resolution	8	Bits	Guaranteed Monotonic
Total Unadjusted Error	± 2	LSB max	
Differential Nonlinearity	± 1	LSB max	
REFERENCE INPUT			
Input Resistance	2	k Ω min	Occurs when each DAC is loaded with all 0s. Occurs when each DAC is loaded with all 1s.
Input Capacitance ³	50 200	pF min pF max	
DIGITAL INPUTS			
Input High Voltage, V_{INH}	2.4	V min	$V_{IN} = 0\text{ V}$ or V_{DD}
Input Low Voltage, V_{INL}	0.8	V max	
Input Leakage Current	± 1	μA max	
Input Capacitance	8	pF max	
Input Coding	Binary		
DYNAMIC PERFORMANCE			
Voltage Output Slew Rate ⁴	2	V/ μs min	Settling Time to $\pm 1/2$ LSB $V_{OUT} = +10\text{ V}$
Voltage Output Settling Time ⁴	4	μs max	
Digital Crosstalk	10	nV secs typ	
Minimum Load Resistance	2	k Ω min	
POWER SUPPLIES			
V_{DD} Range	14.25/15.75	V min/V max	For Specified Performance Outputs Unloaded; $V_{IN} = V_{INL}$ or V_{INH}
I_{DD}	13	mA max	

NOTES

¹Maximum possible reference voltage.²Temperature ranges are as follows:K Version: -40°C to $+85^{\circ}\text{C}$ B Version: -40°C to $+85^{\circ}\text{C}$ ³Guaranteed by design. Not production tested.⁴Sample Tested at 25°C to ensure compliance.
Specifications subject to change without notice.**ABSOLUTE MAXIMUM RATINGS¹**

V_{DD} to AGND	-0.3 V , $+17\text{ V}$
V_{DD} to DGND	-0.3 V , $+17\text{ V}$
V_{SS} to AGND	-7 V , V_{DD}
V_{SS} to DGND	-7 V , V_{DD}
V_{DD} to V_{SS}	-0.3 V , $+24\text{ V}$
AGND to DGND	-0.3 V , V_{DD}
Digital Input Voltage to DGND	-0.3 V , $V_{DD} + 0.3\text{ V}$
V_{REF} to AGND	-0.3 V , V_{DD}
V_{OUT} to AGND ²	V_{SS} , V_{DD}
Power Dissipation (Any Package) to 75°C	500 mW
Derates above 75°C by	2.0 mW/ $^{\circ}\text{C}$
Operating Temperature	
Commercial (K Version)	-40°C to $+85^{\circ}\text{C}$
Industrial (B Version)	-40°C to $+85^{\circ}\text{C}$
Storage Temperature	-65°C to $+150^{\circ}\text{C}$
Lead Temperature (Soldering, 10 secs)	300°C

NOTES

¹Stresses above those listed under Absolute Maximum Ratings may cause permanent damage to the device. This is a stress rating only, functional operation of the device at these or any other conditions above those indicated in the operational sections of this specification is not implied. Exposure to absolute maximum rating conditions for extended periods may affect device reliability.²Outputs may be shorted to AGND provided that the power dissipation of the package is not exceeded. Typically short circuit current to AGND is 50 mA.**CAUTION**

ESD (electrostatic discharge) sensitive device. Electrostatic charges as high as 4000 V readily accumulate on the human body and test equipment and can discharge without detection. Although the AD7226 features proprietary ESD protection circuitry, permanent damage may occur on devices subjected to high energy electrostatic discharges. Therefore, proper ESD precautions are recommended to avoid performance degradation or loss of functionality.



PIN CONFIGURATIONS

DIP and SOIC/SSOP

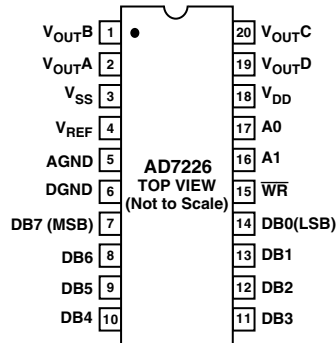

PLCC

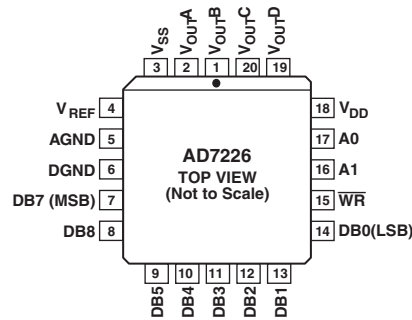

TERMINOLOGY

TOTAL UNADJUSTED ERROR

This is a comprehensive specification that includes full-scale error, relative accuracy and zero code error. Maximum output voltage is $V_{REF} - 1 \text{ LSB}$ (ideal), where 1 LSB (ideal) is $V_{REF}/256$. The LSB size will vary over the V_{REF} range. Hence the zero code error will, relative to the LSB size, increase as V_{REF} decreases. Accordingly, the total unadjusted error, which includes the zero code error, will also vary in terms of LSB's over the V_{REF} range. As a result, total unadjusted error is specified for a fixed reference voltage of 10 V.

RELATIVE ACCURACY

Relative Accuracy or endpoint nonlinearity, is a measure of the maximum deviation from a straight line passing through the endpoints of the DAC transfer function. It is measured after allowing for zero and full-scale error and is normally expressed in LSB's or as a percentage of full-scale reading.

DIFFERENTIAL NONLINEARITY

Differential Nonlinearity is the difference between the measured change and the ideal 1 LSB change between any two adjacent codes. A specified differential nonlinearity of $\pm 1 \text{ LSB}$ max over the operating temperature range ensures monotonicity.

DIGITAL CROSSTALK

The glitch impulse transferred to the output of one converter due to a change in the digital input code to another of the converters. It is specified in nV secs and is measured at $V_{REF} = 0 \text{ V}$.

FULL SCALE ERROR

Full-Scale Error is defined as:

$$\text{Measured Value} - \text{Zero Code Error} - \text{Ideal Value}$$

CIRCUIT INFORMATION

D/A SECTION

The AD7226 contains four identical, 8-bit, voltage mode digital-to-analog converters. The output voltages from the converters have the same polarity as the reference voltage allowing single supply operation. A novel DAC switch pair arrangement on the AD7226 allows a reference voltage range from 2 V to 12.5 V.

Each DAC consists of a highly stable, thin-film, R-2R ladder and eight high speed NMOS, single-pole, double-throw switches. The simplified circuit diagram for one channel is shown in Figure 1. Note that V_{REF} (Pin 4) and AGND (Pin 5) are common to all four DACs.

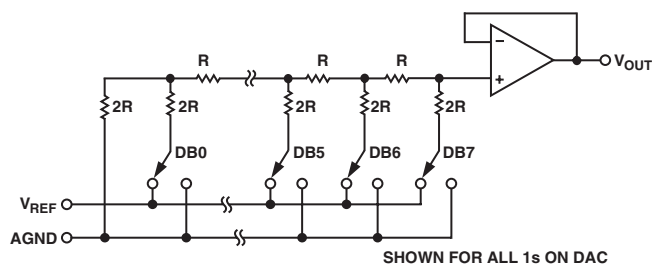

Figure 1. D/A Simplified Circuit Diagram

The input impedance at the V_{REF} pin of the AD7226 is the parallel combination of the four individual DAC reference input impedances. It is code dependent and can vary from 2 k Ω to infinity. The lowest input impedance (i.e., 2 k Ω) occurs when all four DACs are loaded with the digital code 01010101. Therefore, it is important that the reference presents a low output impedance under changing load conditions. The nodal capacitance at the reference terminals is also code dependent and typically varies from 100 pF to 250 pF.

Each V_{OUT} pin can be considered as a digitally programmable voltage source with an output voltage of:

$$V_{OUTX} = D_X V_{REF} \quad (1)$$

where D_X is fractional representation of the digital input code and can vary from 0 to 255/256.

The source impedance is the output resistance of the buffer amplifier.

OP AMP SECTION

Each voltage-mode D/A converter output is buffered by a unity gain, noninverting CMOS amplifier. This buffer amplifier is capable of developing 10 V across a 2 k Ω load and can drive capacitive loads of 3300 pF. The output stage of this amplifier consists of a bipolar transistor from the V_{DD} line and a current load to the V_{SS} , the negative supply for the output amplifiers. This output stage is shown in Figure 2.

The NPN transistor supplies the required output current drive (up to 5 mA). The current load consists of NMOS transistors which normally act as a constant current sink of 400 μ A to V_{SS} , giving each output a current sink capability of approximately 400 μ A if required.

The AD7226 can be operated single or dual supply resulting in different performance in some parameters from the output amplifiers.

In single supply operation ($V_{SS} = 0$ V = AGND), with the output approaching AGND (i.e., digital code approaching all 0s)

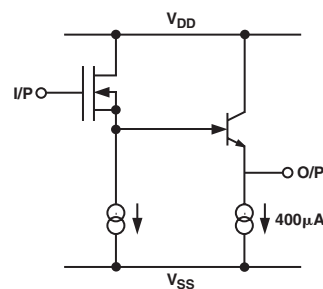

Figure 2. Amplifier Output Stage

the current load ceases to act as a current sink and begins to act as a resistive load of approximately 2 k Ω to AGND. This occurs as the NMOS transistors come out of saturation. This means that, in single supply operation, the sink capability of the amplifiers is reduced when the output voltage is at or near AGND. A typical plot of the variation of current sink capability with output voltage is shown in Figure 3.

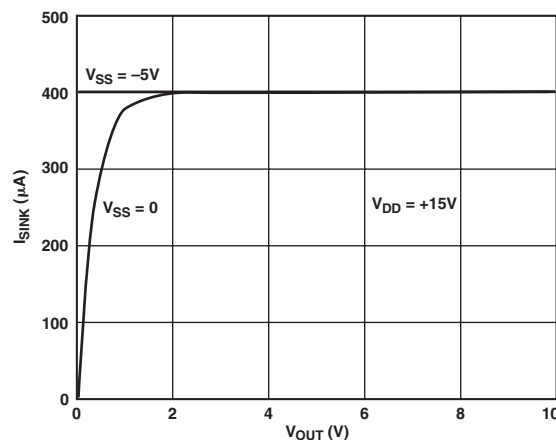

Figure 3. Variation of I_{SINK} with V_{OUT}

If the full sink capability is required with output voltages at or near AGND (= 0 V), then V_{SS} can be brought below 0 V by 5 V and thereby maintain the 400 μ A current sink as indicated in Figure 3. Biasing V_{SS} below 0 V also gives additional headroom in the output amplifier which allows for better zero code error performance on each output. Also improved is the slew rate and negative-going settling time of the amplifiers (discussed later).

Each amplifier offset is laser trimmed during manufacture to eliminate any requirement for offset nulling.

DIGITAL SECTION

The digital inputs of the AD7226 are both TTL and CMOS (5 V) compatible from $V_{DD} = 11.4$ V to 16.5 V. All logic inputs are static protected MOS gates with typical input currents of less than 1 nA. Internal input protection is achieved by an on-chip distributed diode from DGND to each MOS gate. To minimize power supply currents, it is recommended that the digital input voltages be driven as close to the supply rails (V_{DD} and DGND) as practically possible.

AD7226

INTERFACE LOGIC INFORMATION

Address lines A0 and A1 select which DAC will accept data from the input port. Table I shows the selection table for the four DACs with Figure 4 showing the input control logic. When the \overline{WR} signal is LOW, the input latches of the selected DAC are transparent and its output responds to activity on the data bus. The data is latched into the addressed DAC latch on the rising edge of \overline{WR} . While \overline{WR} is high the analog outputs remain at the value corresponding to the data held in their respective latches.

Table I. AD7226 Truth Table

AD7226 Control Inputs			AD7226 Operation
\overline{WR}	A1	A0	
H	X	X	No Operation Device Not Selected
L	L	L	DAC A Transparent
\nearrow	L	L	DAC A Latched
L	L	H	DAC B Transparent
\nearrow	L	H	DAC B Latched
L	H	L	DAC C Transparent
\nearrow	H	L	DAC C Latched
L	H	H	DAC D Transparent
\nearrow	H	H	DAC D Latched

L = Low State, H = High State, X = Don't Care

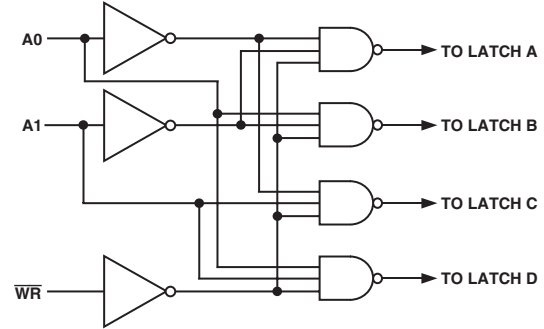
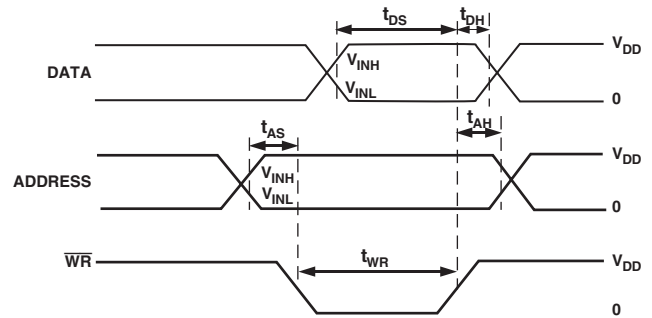

Figure 4. Input Control Logic



NOTES

- ALL INPUT SIGNAL RISE AND FALL TIMES MEASURED FROM 10% TO 90% OF V_{DD} .
 $t_r = t_f = 20\text{ns}$ OVER V_{DD} RANGE.
- TIMING MEASUREMENT REFERENCE LEVEL IS
$$\frac{V_{INH} + V_{INL}}{2}$$
- SELECTED INPUT LATCH IS TRANSPARENT WHILE \overline{WR} IS LOW, THUS INVALID DATA DURING THIS TIME CAN CAUSE SPURIOUS OUTPUTS.

Figure 5. Write Cycle Timing Diagram

Typical Performance Characteristics—AD7226

($T_A = 25^\circ\text{C}$, $V_{DD} = 15\text{ V}$, $V_{SS} = -5\text{ V}$)

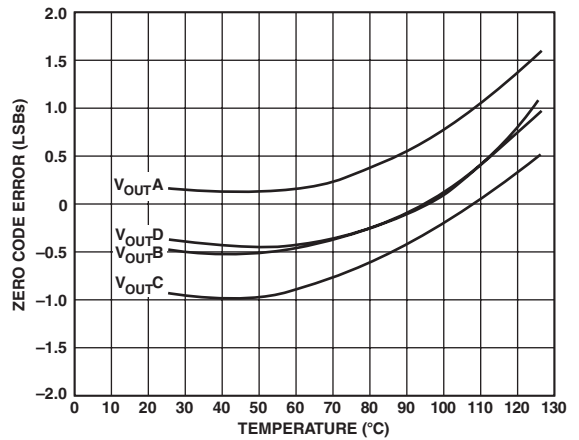
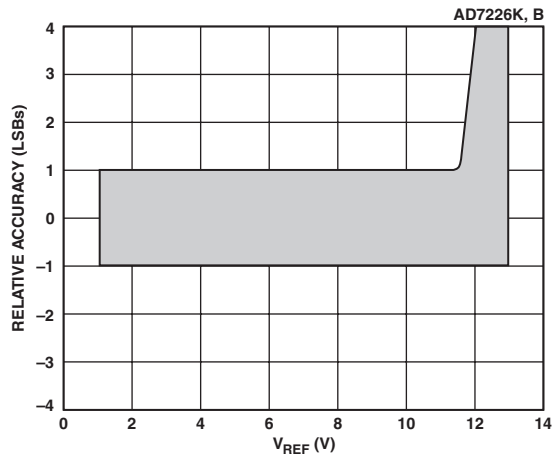
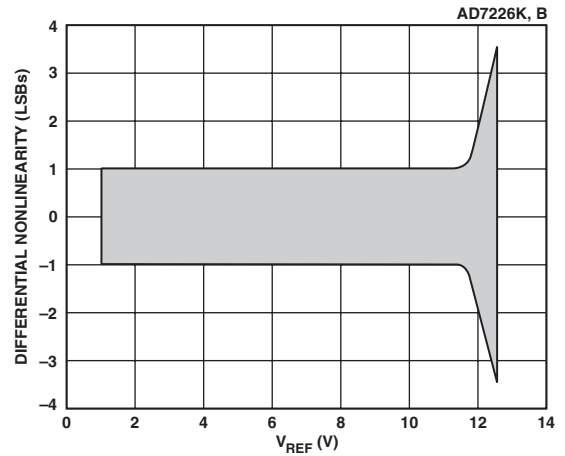
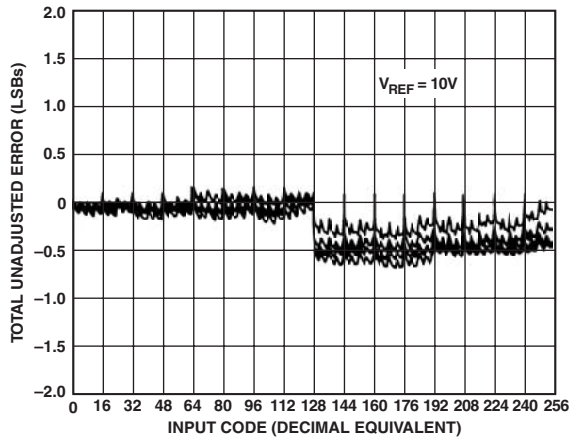

AD7226

SPECIFICATION RANGES

In order for the DACs to operate to their specifications, the reference voltage must be at least 4 V below the V_{DD} power supply voltage. This voltage differential is required for correct generation of bias voltages for the DAC switches.

The AD7226 is specified to operate over a V_{DD} range from $+12\text{ V} \pm 5\%$ to $+15\text{ V} \pm 10\%$ (i.e., from $+11.4\text{ V}$ to $+16.5\text{ V}$) with a V_{SS} of $-5\text{ V} \pm 10\%$. Operation is also specified for a single $+15\text{ V} \pm 5\%$ V_{DD} supply. Applying a V_{SS} of -5 V results in improved zero code error, improved output sink capability with outputs near AGND and improved negative-going settling time.

Performance is specified over a wide range of reference voltages from 2 V to $(V_{DD} - 4\text{ V})$ with dual supplies. This allows a range of standard reference generators to be used such as the AD780, a 2.5 V band gap reference and the AD584, a precision 10 V reference. Note that in order to achieve an output voltage range of 0 V to 10 V a nominal $15\text{ V} \pm 5\%$ power supply voltage is required by the AD7226.

SETTLING TIME

The output stage of the buffer amplifiers consists of a bipolar NPN transistor from the V_{DD} line and a constant current load to V_{SS} . V_{SS} is the negative power supply for the output buffer amplifiers. As mentioned in the op amp section, in single supply operation the NMOS transistor will come out of saturation as the output voltage approaches AGND and will act as a resistive load of approximately $2\text{ k}\Omega$ to AGND. As a result, the settling time for negative-going signals approaching AGND in single supply operation will be longer than for dual supply operation where the current load of $400\text{ }\mu\text{A}$ is maintained all the way down to AGND. Positive-going settling-time is not affected by V_{SS} .

The settling-time for the AD7226 is limited by the slew-rate of the output buffer amplifiers. This can be seen from Figure 6 which shows the dynamic response for the AD7226 for a full scale change. Figures 7a and 7b show expanded settling-time photographs with the output waveforms derived from a differential input to an oscilloscope. Figure 7a shows the settling time for a positive-going step and Figure 7b shows the settling time for a negative-going output step.

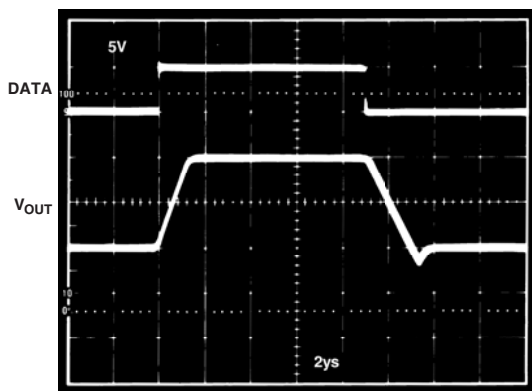

Figure 6. Dynamic Response ($V_{SS} = -5\text{ V}$)

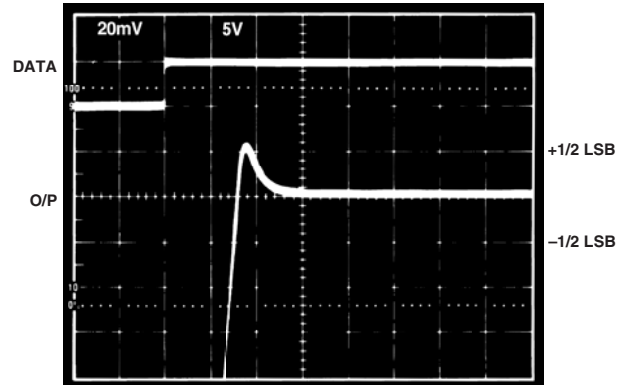

Figure 7a. Positive Step Settling Time ($V_{SS} = -5\text{ V}$)

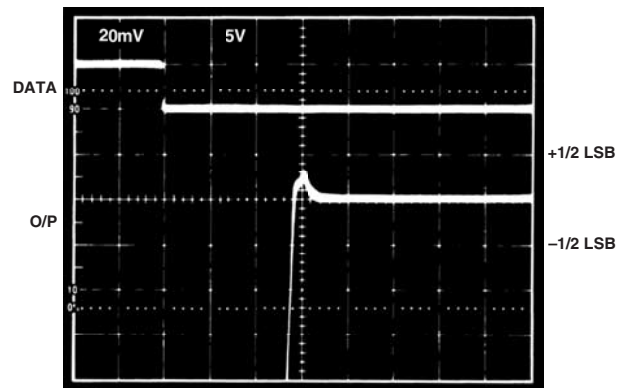

Figure 7b. Negative Step Settling Time ($V_{SS} = -5\text{ V}$)

GROUND MANAGEMENT

AC or transient voltages between AGND and DGND can cause noise at the analog output. This is especially true in microprocessor systems where digital noise is prevalent. The simplest method of ensuring that voltages at AGND and DGND are equal is to tie AGND and DGND together at the AD7226. In more complex systems where the AGND and DGND intertie is on the backplane, it is recommended that two diodes be connected in inverse parallel between the AD7226 AGND and DGND pins (IN914 or equivalent).

Unipolar Output Operation

This is the basic mode of operation for each channel of the AD7226, with the output voltage having the same positive polarity as $+V_{REF}$. The AD7226 can be operated single supply ($V_{SS} = \text{AGND}$) or with positive/negative supplies (see op amp section which outlines the advantages of having negative V_{SS}). The code table for unipolar output operation is shown in Table II. Note that the voltage at V_{REF} must never be negative with respect to DGND in order to prevent parasitic transistor turn-on. Connections for the unipolar output operation are shown in Figure 8.

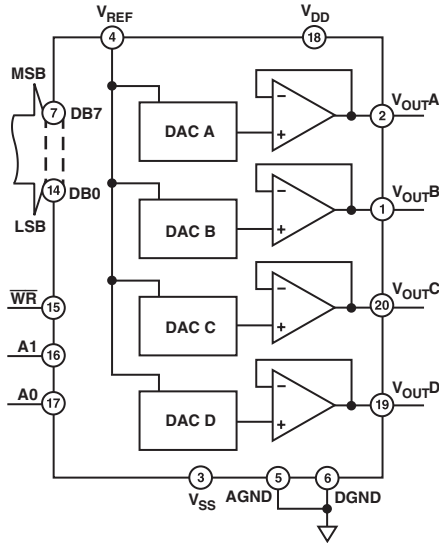

Figure 8. AD7226 Unipolar Output Circuit

Table II. Unipolar Code Table

DAC Latch Contents MSB	LSB	Analog Output
1 1 1 1	1 1 1 1	$+V_{REF} \left(\frac{255}{256} \right)$
1 0 0 0	0 0 0 1	$+V_{REF} \left(\frac{129}{256} \right)$
1 0 0 0	0 0 0 0	$+V_{REF} \left(\frac{128}{256} \right) = +\frac{V_{REF}}{2}$
0 1 1 1	1 1 1 1	$+V_{REF} \left(\frac{127}{256} \right)$
0 0 0 0	0 0 0 1	$+V_{REF} \left(\frac{1}{256} \right)$
0 0 0 0	0 0 0 0	0 V

Note: $LSB = (V_{REF})(2^{-8}) = V_{REF} \left(\frac{1}{256} \right)$ (2)

Bipolar Output Operation

Each of the DACs of the AD7226 can be individually configured to provide bipolar output operation. This is possible using one external amplifier and two resistors per channel. Figure 9 shows a circuit used to implement offset binary coding (bipolar operation) with DAC A of the AD7226. In this case

$$V_{OUT} = \left(1 + \frac{R2}{R1} \right) \times (D_A V_{REF}) - \left(\frac{R2}{R1} \right) \times (V_{REF}) \quad (3)$$

With $R1 = R2$

$$V_{OUT} = (2D_A - 1) \times V_{REF} \quad (4)$$

where D_A is a fractional representation of the digital word in latch A. Mismatch between $R1$ and $R2$ causes gain and offset errors and therefore these resistors must match and track over temperature. Once again the AD7226 can be operated in single supply or from positive/negative supplies. Table III shows the digital code versus output voltage relationship for the circuit of Figure 9 with $R1 = R2$.

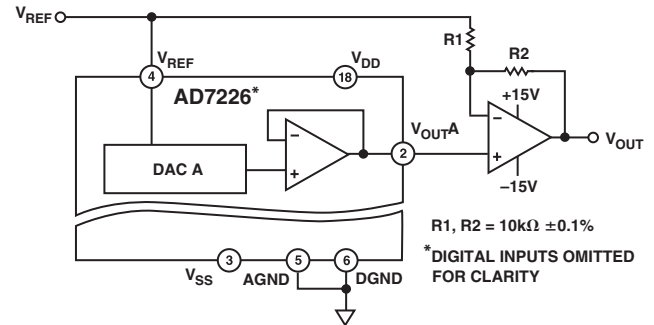

Figure 9. AD7226 Bipolar Output Circuit

Table III. Bipolar (Offset Binary) Code Table

DAC Latch Contents MSB	LSB	Analog Output
1 1 1 1	1 1 1 1	$+V_{REF} \left(\frac{127}{128} \right)$
1 0 0 0	0 0 0 1	$+V_{REF} \left(\frac{1}{128} \right)$
1 0 0 0	0 0 0 0	0 V
0 1 1 1	1 1 1 1	$-V_{REF} \left(\frac{1}{128} \right)$
0 0 0 0	0 0 0 1	$-V_{REF} \left(\frac{127}{128} \right)$
0 0 0 0	0 0 0 0	$-V_{REF} \left(\frac{128}{128} \right) = -V_{REF}$

AGND BIAS

The AD7226 AGND pin can be biased above system GND (AD7226 DGND) to provide an offset “zero” analog output voltage level. Figure 10 shows a circuit configuration to achieve this for channel A of the AD7226. The output voltage, V_{OUTA} , can be expressed as:

$$V_{OUTA} = V_{BIAS} + D_A (V_{IN}) \quad (5)$$

where D_A is a fractional representation of the digital input word ($0 \leq D \leq 255/256$).

AD7226

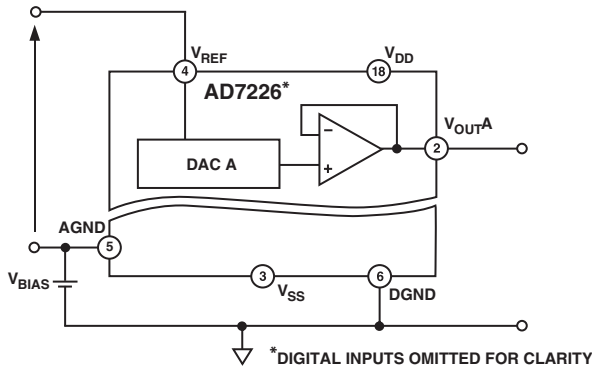

Figure 10. AGND Bias Circuit

For a given V_{IN} , increasing AGND above system GND will reduce the effective $V_{DD}-V_{REF}$ which must be at least 4 V to ensure specified operation. Note that because the AGND pin is common to all four DACs, this method biases up the output voltages of all the DACs in the AD7226. Note that V_{DD} and V_{SS} of the AD7226 should be referenced to DGND.

3-PHASE SINE WAVE

The circuit of Figure 11 shows an application of the AD7226 in the generation of 3-phase sine waves which can be used to control small 3-phase motors. The proper codes for synthesizing a full sine wave are stored in EPROM, with the required phase-shift of 120° between the three D/A converter outputs being generated in software.

Data is loaded into the three D/A converters from the sine EPROM via the microprocessor or control logic. Three loops are

generated in software with each D/A converter being loaded from a separate loop. The loops run through the look-up table producing successive triads of sinusoidal values with 120° separation which are loaded to the D/A converters producing three sine wave voltages 120° apart. A complete sine wave cycle is generated by stepping through the full look-up table. If a 256-element sine wave table is used then the resolution of the circuit will be 1.4° ($360^\circ/256$). Figure 13 shows typical resulting waveforms. The sine waves can be smoothed by filtering the D/A converter outputs.

The fourth D/A converter of the AD7226, DAC D, may be used in a feedback configuration to provide a programmable reference voltage for itself and the other three converters. This configuration is shown in Figure 11. The relationship of V_{REF} to V_{IN} is dependent upon digital code and upon the ratio of R_F to R and is given by the formula.

$$V_{REF} = \frac{(1+G)}{(1+G \times D_D)} \times V_{IN} \quad (6)$$

where $G = R_F/R$

and D_D is a fractional representation of the digital word in latch D.

Alternatively, for a given V_{IN} and resistance ratio, the required value of D_D for a given value of V_{REF} can be determined from the expression

$$D_D = (1 + R/R_F) \times \frac{V_{IN}}{V_{REF}} - \frac{R}{R_F} \quad (7)$$

Figure 12 shows typical plots of V_{REF} versus digital code for three different values of R_F . With $V_{IN} = 2.5$ V and $R_F = 3R$ the peak-to-peak sine wave voltage from the converter outputs will vary between 2.5 V and 10 V over the digital input code range of 0 to 255.

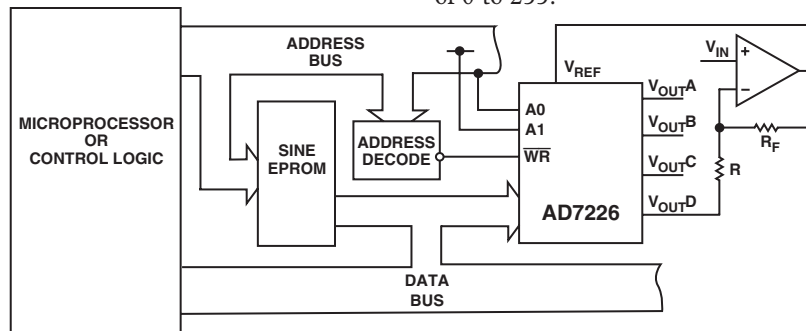

Figure 11. 3-Phase Sine Wave Generation Circuit

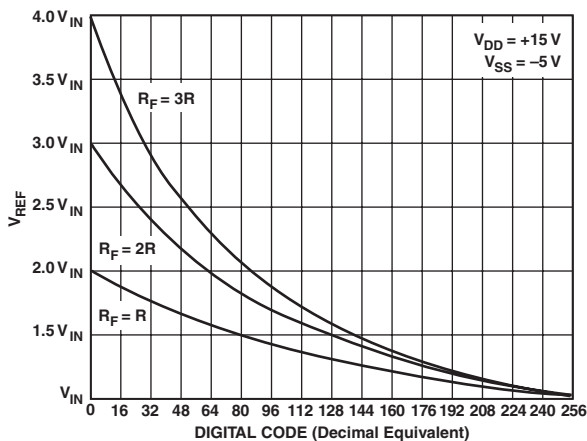

Figure 12. Variation of V_{REF} with Feedback Configuration

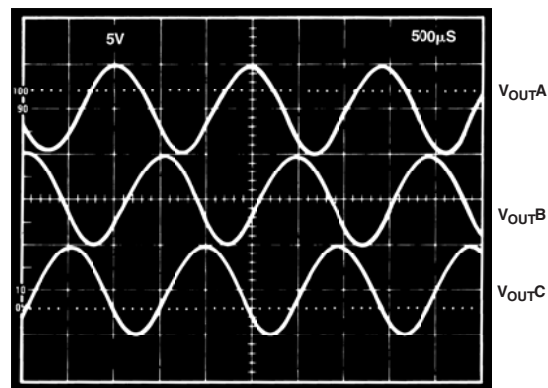

Figure 13. 3-Phase Sine Wave Output

STAIRCASE WINDOW COMPARATOR

In many test systems, it is important to be able to determine whether some parameter lies within defined limits. The staircase window comparator of Figure 14a is a circuit that can be used, for example, to measure the V_{OH} and V_{OL} thresholds of a TTL device under test. Upper and lower limits on both V_{OH} and V_{OL} can be programmably set using the AD7226. Each adjacent pair of comparators forms a window of programmable size. If V_{TEST} lies within a window, then the output for that window will be high. With a reference of 2.56 V applied to the V_{REF} input, the minimum window size is 10 mV.

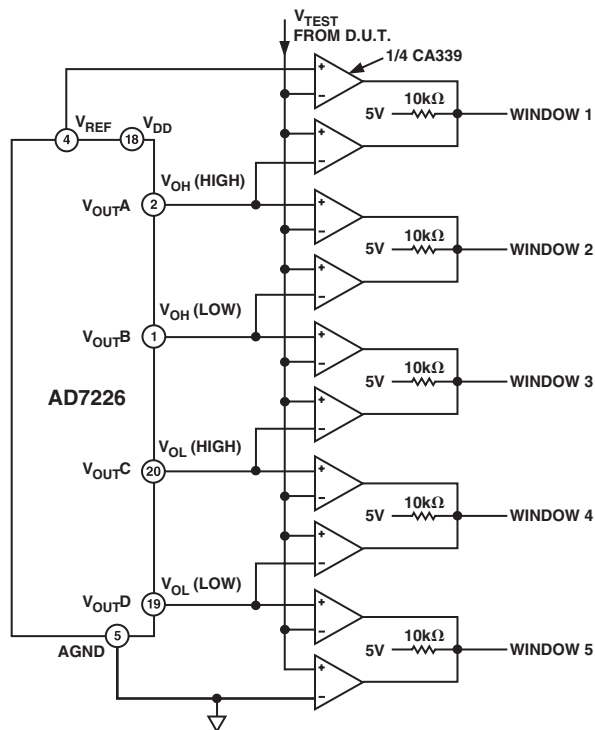

Figure 14a. Logic Level Measurement

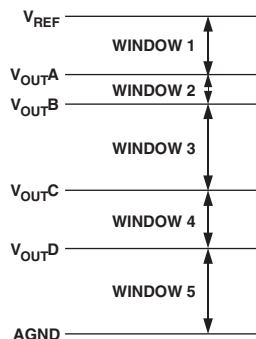

Figure 14b. Window Structure

The circuit can easily be adapted to allow for overlapping of windows as shown in Figure 15a. If the three outputs from this circuit are decoded then five different nonoverlapping programmable windows can again be defined.

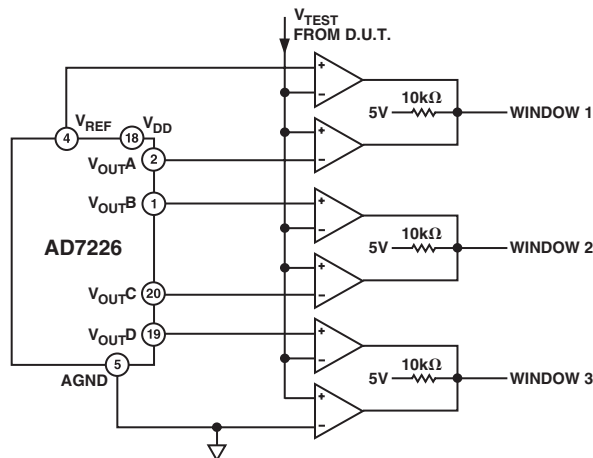

Figure 15a. Overlapping Windows

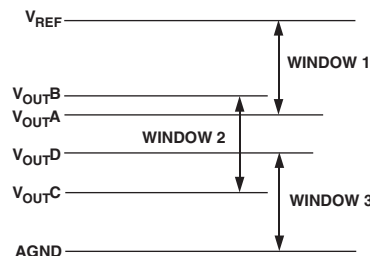

Figure 15b. Window Structure

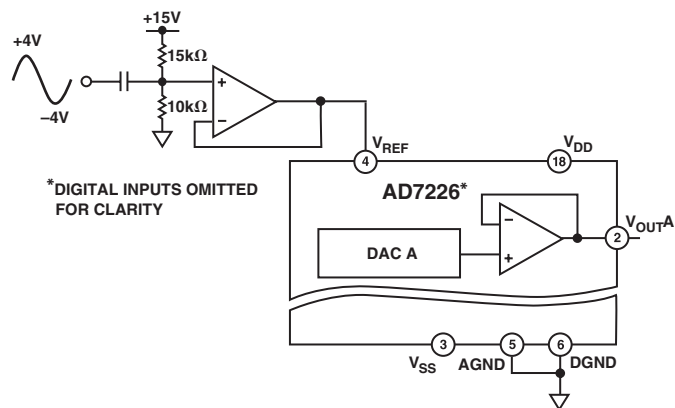

Figure 16. Varying Reference Signal

VARYING REFERENCE SIGNAL

In some applications, it may be desirable to have a varying signal applied to the reference input of the AD7226. The AD7226 has multiplying capability within upper and lower limits of reference voltage when operated with dual supplies. The upper and lower limits are those required by the AD7226 to achieve its linearity specification. Figure 16 shows a sine wave signal applied to the reference input of the AD7226. For input signal frequencies up to 50 kHz, the output distortion typically remains less than 0.1%. Typical 3 dB bandwidth figure is 700 kHz.

AD7226

OFFSET ADJUST

Figure 17 shows how the AD7226 can be used to provide programmable input offset voltage adjustment for the AD544 op amp. Each output of the AD7226 can be used to trim the input offset voltage on one AD544. The 620 kΩ resistor tied to 10 V provides a fixed bias current to one offset node. For symmetrical adjustment, this bias current should equal the current in the other offset node with the half-full scale code (i.e., 10000000) on the DAC. Changing the code on the DAC varies the bias current and hence provides offset adjust for the AD544. For example, the input offset voltage on the AD544J, which has a maximum of ±2 mV, can be programmably trimmed to ±10 μV.

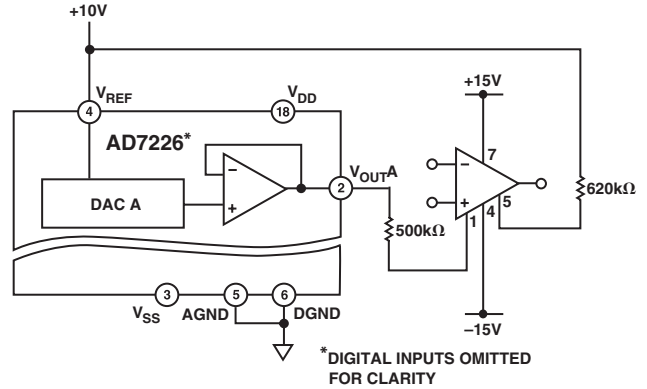

Figure 17. Offset Adjust for AD544

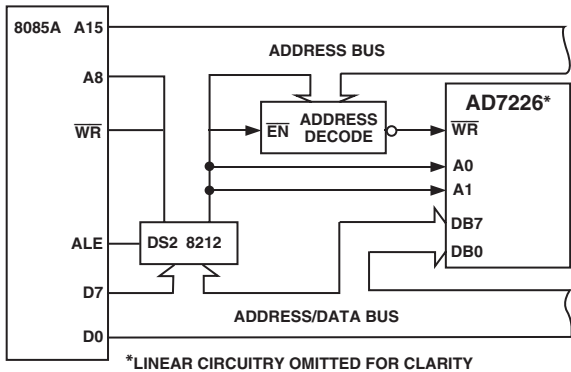

Figure 18. AD7226 to 8085A Interface

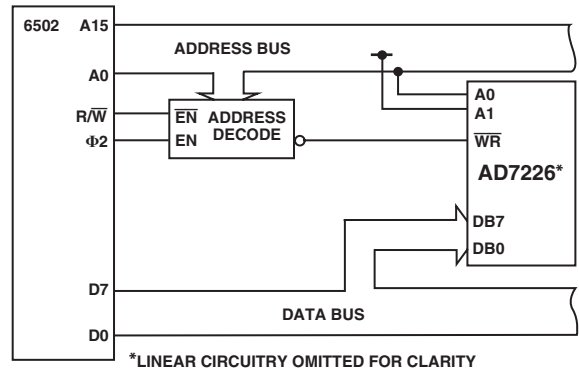

Figure 20. AD7226 to 6502 Interface

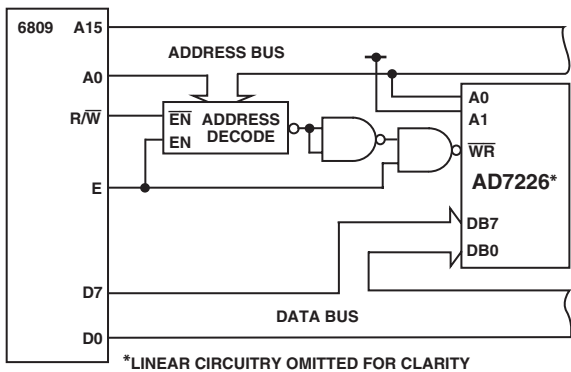

Figure 19. AD7226 to 6809 Interface

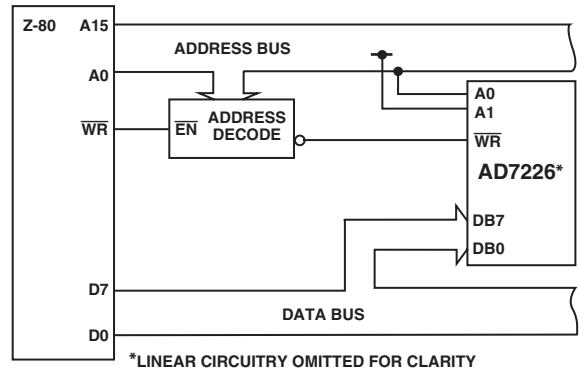
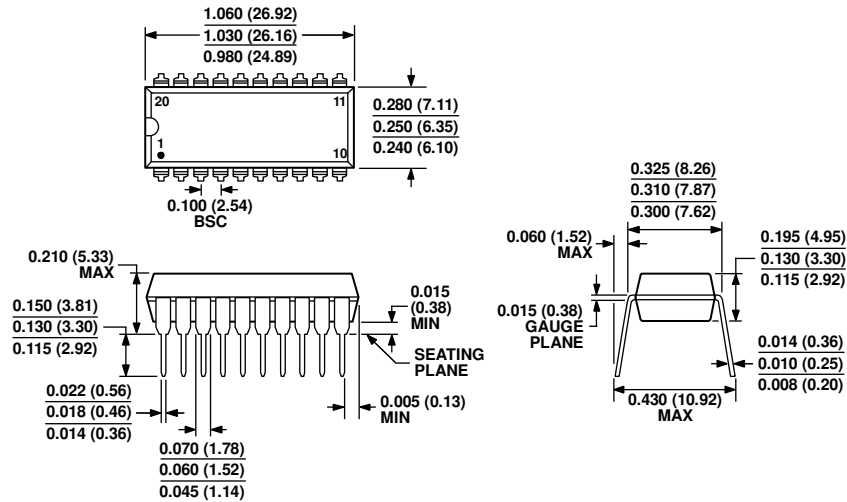

Figure 21. AD7226 to Z-80 Interface

OUTLINE DIMENSIONS



COMPLIANT TO JEDEC STANDARDS MS-001
 CONTROLLING DIMENSIONS ARE IN INCHES; MILLIMETER DIMENSIONS (IN PARENTHESES) ARE ROUNDED-OFF INCH EQUIVALENTS FOR REFERENCE ONLY AND ARE NOT APPROPRIATE FOR USE IN DESIGN. CORNER LEADS MAY BE CONFIGURED AS WHOLE OR HALF LEADS.

Figure 1. 20-Lead Plastic Dual In-Line Package [PDIP] Narrow Body (N-20)

Dimensions shown in inches and (millimeters)

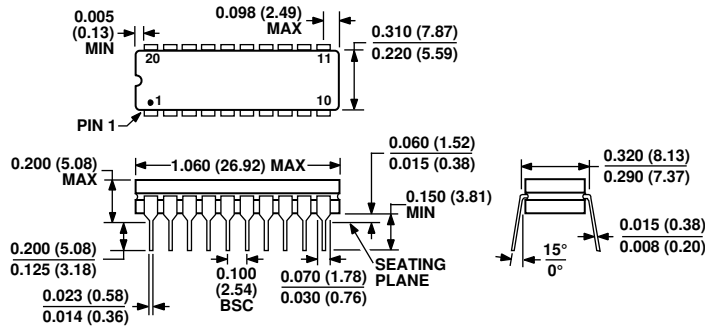

CONTROLLING DIMENSIONS ARE IN INCHES; MILLIMETER DIMENSIONS (IN PARENTHESES) ARE ROUNDED-OFF INCH EQUIVALENTS FOR REFERENCE ONLY AND ARE NOT APPROPRIATE FOR USE IN DESIGN.

Figure 2. 20-Lead Ceramic Dual In-Line Package [CERDIP] (Q-20)

Dimensions shown in inches and (millimeters)

070706-A

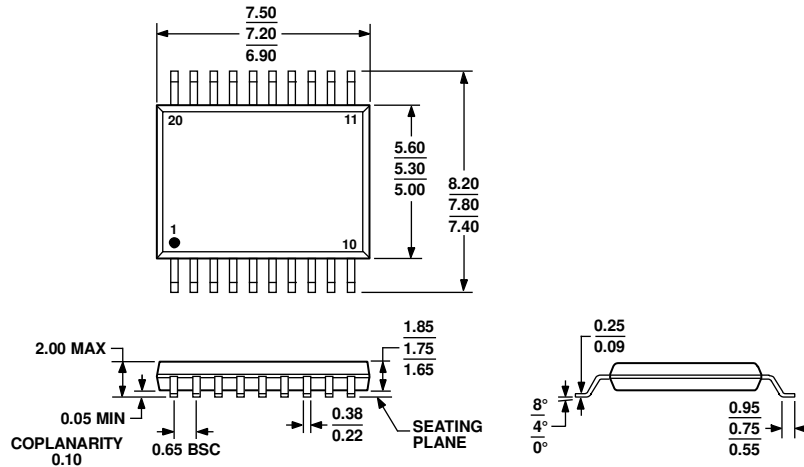

COMPLIANT TO JEDEC STANDARDS MO-150-AE

Figure 3. 20-Lead Shrink Small Outline Package [SSOP] (RS-20)

Dimensions shown in millimeters

060106-A

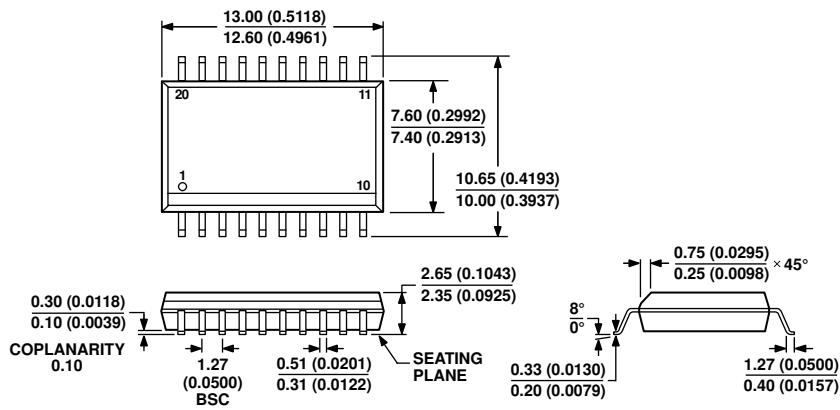

COMPLIANT TO JEDEC STANDARDS MS-013-AC

CONTROLLING DIMENSIONS ARE IN MILLIMETERS; INCH DIMENSIONS (IN PARENTHESES) ARE ROUNDED-OFF MILLIMETER EQUIVALENTS FOR REFERENCE ONLY AND ARE NOT APPROPRIATE FOR USE IN DESIGN.

Figure 4. 20-Lead Standard Small Outline Package [SOIC_W] Wide Body (RW-20)

Dimensions shown in millimeters and (inches)

06-07-2006-A

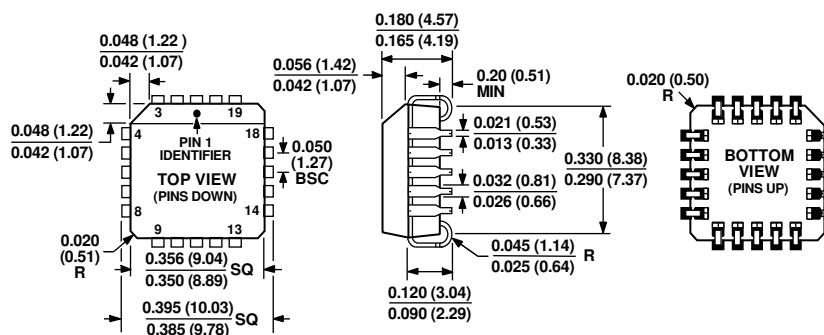

COMPLIANT TO JEDEC STANDARDS MO-047-AA
 CONTROLLING DIMENSIONS ARE IN INCHES; MILLIMETER DIMENSIONS
 (IN PARENTHESES) ARE ROUNDED-OFF INCH EQUIVALENTS FOR
 REFERENCE ONLY AND ARE NOT APPROPRIATE FOR USE IN DESIGN.

Figure 5. 20-Lead Plastic Leaded Chip Carrier (PLCC)

(P-20A)

Dimensions shown in inches and (millimeters)

ORDERING GUIDE

Model ¹	Temperature Range	Total Unadjusted Error ²	Package Description	Package Option ³
AD7226BQ	-40°C to +85°C	±1 LSB	20 Lead CERDIP	Q-20
AD7226BRSZ	-40°C to +85°C	±1 LSB	20 Lead SSOP	RS-20
AD7226KN	-40°C to +85°C	±1 LSB	20 Lead PDIP	N-20
AD7226KNZ	-40°C to +85°C	±1 LSB	20 Lead PDIP	N-20
AD7226KP	-40°C to +85°C	±1 LSB	20 Lead PLCC	P-20A
AD7226KP-REEL	-40°C to +85°C	±1 LSB	20 Lead PLCC	P-20A
AD7226KPZ	-40°C to +85°C	±1 LSB	20 Lead PLCC	P-20A
AD7226KPZ-REEL	-40°C to +85°C	±1 LSB	20 Lead PLCC	P-20A
AD7226KR	-40°C to +85°C	±1 LSB	20 Lead SOIC - Wide	RW-20
AD7226KR-REEL	-40°C to +85°C	±1 LSB	20 Lead SOIC - Wide	RW-20
AD7226KRZ	-40°C to +85°C	±1 LSB	20 Lead SOIC - Wide	RW-20
AD7226KRZ-REEL	-40°C to +85°C	±1 LSB	20 Lead SOIC - Wide	RW-20
AD7226BCHIPS	-40°C to +85°C	±1 LSB	Chips or Die	

¹ Z = ROHS Compliant Part.

² Dual supply operation.

³ N = plastic DIP; P = plastic leaded chip carrier; Q = CERDIP; RW = SPIC; RS = SSOP.

REVISION HISTORY

1/11—Rev. C to Rev. D

Changes to Ordering Guide.....15

3/03—Rev. B to Rev. C

Title Revision1

3/03—Rev. A to Rev. B

Edits to Features1

Edits to Specifications.....2

Edits to Ordering Guide.....3

Edits to Absolute Maximum Ratings.....3

Edits to Pin Configurations4

Edits to Specifications Ranges8

Outline Dimensions Updated.....13

RS-20 Package Added.....13

Updated RS-20 Package Outline Dimensions.....13

AD7226

NOTES