



Chipsmall Limited consists of a professional team with an average of over 10 year of expertise in the distribution of electronic components. Based in Hongkong, we have already established firm and mutual-benefit business relationships with customers from,Europe,America and south Asia,supplying obsolete and hard-to-find components to meet their specific needs.

With the principle of "Quality Parts,Customers Priority,Honest Operation,and Considerate Service",our business mainly focus on the distribution of electronic components. Line cards we deal with include Microchip,ALPS,ROHM,Xilinx,Pulse,ON,Everlight and Freescale. Main products comprise IC,Modules,Potentiometer,IC Socket,Relay,Connector.Our parts cover such applications as commercial,industrial, and automotives areas.

We are looking forward to setting up business relationship with you and hope to provide you with the best service and solution. Let us make a better world for our industry!



Contact us

Tel: +86-755-8981 8866 Fax: +86-755-8427 6832

Email & Skype: info@chipsmall.com Web: www.chipsmall.com

Address: A1208, Overseas Decoration Building, #122 Zhenhua RD., Futian, Shenzhen, China



FEATURES

Dual simultaneous sampling 12-bit, 2-channel analog-to-digital converter (ADC)

True differential analog inputs

Programmable gain stage: $\times 1, \times 2, \times 3, \times 4, \times 6, \times 8, \times 12, \times 16, \times 24, \times 32, \times 48, \times 64, \times 96, \times 128$

Throughput rate per ADC

1 MSPS for **AD7262**

500 kSPS for **AD7262-5**

Analog input impedance: $>1\text{ G}\Omega$

Wide input bandwidth

-3 dB bandwidth: 1.7 MHz at gain = 2

4 on-chip comparators

SNR: 73 dB typical at gain = 2, 66 dB typical at gain = 32

Device offset calibration, system gain calibration

On-chip reference: 2.5 V

-40°C to $+105^\circ\text{C}$ operation

High speed serial interface

SPI/QSPI™/MICROWIRE/DSP compatible

48-lead LFCSP and LQFP

GENERAL DESCRIPTION

The **AD7262/AD7262-5** are dual, 12-bit, high speed, low power, successive approximation ADCs that operate from a single 5 V power supply. The **AD7262** features throughput rates of up to 1 MSPS per on-chip ADC. The **AD7262-5** features throughput rates of up to 500 kSPS. Two complete ADC functions allow simultaneous sampling and conversion of two channels. Each ADC is preceded by a true differential analog input with a PGA. There are 14 gain settings available: $\times 1, \times 2, \times 3, \times 4, \times 6, \times 8, \times 12, \times 16, \times 24, \times 32, \times 48, \times 64, \times 96, \text{ and } \times 128$.

The **AD7262/AD7262-5** contain four comparators. Comparator A and Comparator B are optimized for low power, while Comparator C and Comparator D have fast propagation delays. The **AD7262/AD7262-5** feature a calibration function to remove any device offset error and programmable gain adjust registers to allow for input path (for example, sensor) offset and gain compensation. The **AD7262/AD7262-5** have an on-chip 2.5 V reference that can be disabled if an external reference is preferred.

The **AD7262/AD7262-5** are ideally suited for monitoring small amplitude signals from a variety of sensors. They include all the functionality needed for monitoring the position feedback signals from a variety of analog encoders used in motor control systems.

FUNCTIONAL BLOCK DIAGRAM

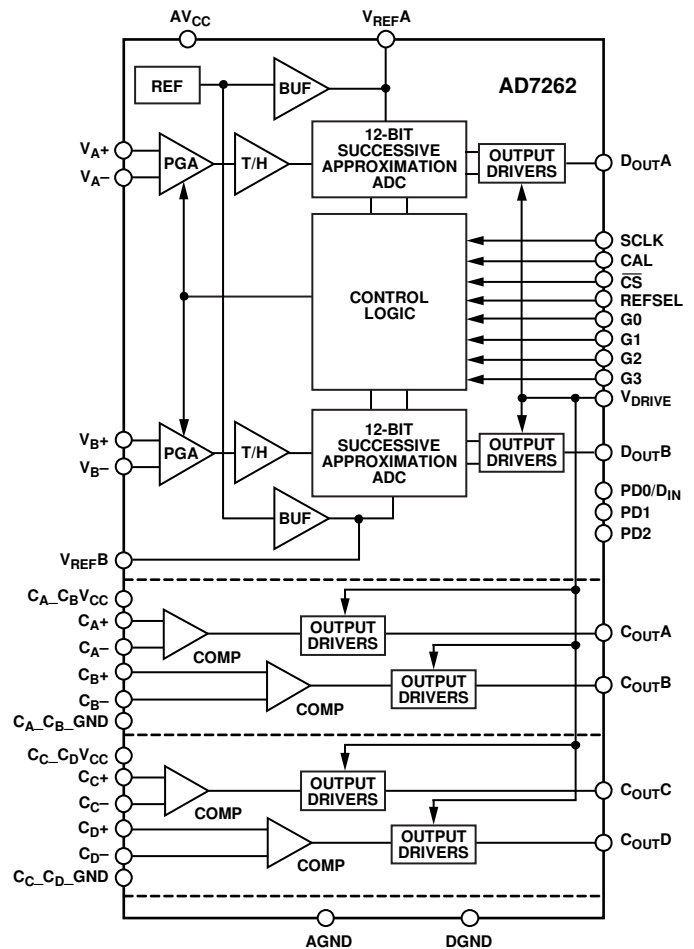

Figure 1.

PRODUCT HIGHLIGHTS

1. Integrated PGA with a variety of flexible gain settings to allow detection and conversion of low level analog signals.
2. Each PGA is followed by a dual simultaneous sampling ADC, featuring throughput rates of 1 MSPS per ADC for the **AD7262**. The conversion results of both ADCs are simultaneously available on separate datalines or in succession on one data line if only one serial port is available.
3. Four integrated comparators that can be used to count signals from pole sensors in motor control applications.
4. Internal 2.5 V reference.

AD7262* PRODUCT PAGE QUICK LINKS

Last Content Update: 02/23/2017

COMPARABLE PARTS

View a parametric search of comparable parts.

EVALUATION KITS

- AD7262 Evaluation Board

DOCUMENTATION

Data Sheet

- AD7262: 1 MSPS, 12-Bit, Simultaneous Sampling SAR ADC with PGA and Four Comparators Data Sheet

SOFTWARE AND SYSTEMS REQUIREMENTS

- CED1Z FPGA Project for AD7262 with Nios driver

REFERENCE MATERIALS

Technical Articles

- MS-2210: Designing Power Supplies for High Speed ADC

DESIGN RESOURCES

- AD7262 Material Declaration
- PCN-PDN Information
- Quality And Reliability
- Symbols and Footprints

DISCUSSIONS

View all AD7262 EngineerZone Discussions.

SAMPLE AND BUY

Visit the product page to see pricing options.

TECHNICAL SUPPORT

Submit a technical question or find your regional support number.

DOCUMENT FEEDBACK

Submit feedback for this data sheet.

TABLE OF CONTENTS

Features	1	Application Details.....	20
General Description	1	Modes of Operation	22
Functional Block Diagram	1	Pin-Driven Mode	22
Product Highlights	1	Gain Selection.....	22
Revision History	2	Power-Down Modes	22
Specifications.....	3	Control Register	23
Timing Specifications	6	On-Chip Registers.....	24
Timing Diagram	6	Serial Interface	25
Absolute Maximum Ratings.....	7	Calibration.....	27
ESD Caution.....	7	Internal Offset Calibration.....	27
Pin Configurations and Function Descriptions	8	Adjusting the Offset Calibration Registers.....	28
Typical Performance Characteristics	10	System Gain Calibration.....	28
Terminology	14	Microprocessor Interfacing.....	29
Theory of Operation	15	AD7262/AD7262-5 to ADSP-BF531	29
Circuit Information.....	15	Application Hints	30
Comparators.....	15	Grounding and Layout	30
Operation.....	15	PCB Design Guidelines for LFCSP	30
Analog Inputs.....	15	Outline Dimensions	31
V _{DRIVE}	16	Ordering Guide	31
Reference	17		
Typical Connection Diagrams	17		

REVISION HISTORY

11/2016—Rev. A to Rev. B

Change to Figure 4	8	Changes to Table 4.....	9
Change to Pin 31, 32 Description, Table 4	9	Change to Serial Interface Section	25
Changes to Serial Interface Section.....	25	Changes to Figure 34 and Figure 34 Caption	26
Changes to Figure 34 and Figure 34 Caption	26	Change to Microprocessor Interfacing Section and Figure 37	29
Updated Outline Dimensions	31	Changes to AD7262/AD7262-5 to ADSP-BF531 Section.....	29
Changes to Ordering Guide	31	Updated Outline Dimensions.....	31

8/2015—Rev. 0 to Rev. A

Changed ADSP-BF53x to ADSP-BF531	Throughout
--	------------

7/2008—Revision 0: Initial Version

SPECIFICATIONS

$V_{CC} = 4.75\text{ V to }5.25\text{ V}$, $C_A_C_B V_{CC} = C_C_C_D V_{CC} = 2.7\text{ V to }5.25\text{ V}$, $V_{DRIVE} = 2.7\text{ V to }5.25\text{ V}$, $f_{SAMPLE} = 1\text{ MSPS}$ and $f_{SCLK} = 40\text{ MHz}$ for AD7262, $f_{SAMPLE} = 500\text{ kSPS}$ and $f_{SCLK} = 20\text{ MHz}$ for AD7262-5, $V_{REF} = 2.5\text{ V internal/external}$; $T_A = -40^\circ\text{C to }+105^\circ\text{C}$, unless otherwise noted.

Table 1.

Parameter	Min	Typ	Max	Unit	Test Conditions/Comments
DYNAMIC PERFORMANCE¹					
Signal-to-Noise Ratio (SNR) ²	70	73		dB	$f_{IN} = 100\text{ kHz}$ sine wave PGA gain setting = 2
Signal-to-(Noise + Distortion) Ratio (SINAD) ²	70	72		dB	
Total Harmonic Distortion (THD) ²		-85	-77	dB	
Spurious-Free Dynamic Range (SFDR) ²		-97		dB	
Common-Mode Rejection Ratio (CMRR) ³		-76		dB	For PGA gain setting = 2, ripple frequency of 50 Hz/60 Hz; see Figure 17 and Figure 18
ADC-to-ADC Isolation ³		-90		dB	
Bandwidth ³		1.2		MHz	@ -3 dB; PGA gain setting = 128
		1.7		MHz	@ -3 dB; PGA gain setting = 2
DC ACCURACY					
Resolution			12	Bits	
Integral Nonlinearity ²		±0.5	±1	LSB	
Differential Nonlinearity ²		±0.5	±0.99	LSB	Guaranteed no missed codes to 12 bits
Positive Full-Scale Error ²		±0.122	±0.305	% FSR	Pregain calibration
		±0.018		% FSR	Postgain calibration
Positive Full-Scale Error Match		±0.061		% FSR	
Zero Code Error ²		±0.092	±0.244	% FSR	Preoffset and pregain calibration
		±0.012		% FSR	Postoffset and postgain calibration
Zero Code Error Match		±0.061		% FSR	
Negative Full-Scale Error ²		±0.122	±0.305	% FSR	Pregain calibration
		±0.018		% FSR	Postgain calibration
Negative Full-Scale Error Match		±0.061		% FSR	
Zero Code Error Drift		2.5		μV/°C	
ANALOG INPUT					
Input Voltage Range, V_{IN+} and V_{IN-}		$V_{CM} \pm \frac{V_{REF}}{2 \times \text{Gain}}$		V	$V_{CM} = AV_{CC}/2$; PGA gain setting ≥ 2
Common-Mode Voltage Range, V_{CM}	$V_{CM} - 100\text{ mV}$		$V_{CM} + 100\text{ mV}$	V	$V_{CM} = 2$; PGA gain setting = 1; see Figure 19 ⁴
	$(V_{CC}/2) - 0.4$		$(V_{CC}/2) + 0.2$	V	$V_{CM} = AV_{CC}/2$; PGA gain setting = 2
	$(V_{CC}/2) - 0.4$		$(V_{CC}/2) + 0.4$	V	$V_{CM} = AV_{CC}/2$; $3 \leq \text{PGA gain setting} \leq 32$
	$(V_{CC}/2) - 0.6$		$(V_{CC}/2) + 0.8$	V	$V_{CM} = AV_{CC}/2$; PGA gain setting ≥ 48
DC Leakage Current		±0.001	±1	μA	
Input Capacitance ³		5		pF	
Input Impedance ³		1		GΩ	
REFERENCE INPUT/OUTPUT					
Reference Output Voltage ⁵	2.495	2.5	2.505	V	$2.5\text{ V} \pm 5\text{ mV max @ }25^\circ\text{C}$
Reference Input Voltage Range		2.5		V	
DC Leakage Current		±0.3	±1	μA	External reference applied to Pin V_{REFA} /Pin V_{REFB}
Input Capacitance ³		20		pF	
V_{REFA} , V_{REFB} Output Impedance ³		4		Ω	
Reference Temperature Coefficient		20		ppm/°C	
V_{REF} Noise ³		20		μV rms	

Parameter	Min	Typ	Max	Unit	Test Conditions/Comments
LOGIC INPUTS					
Input High Voltage, V_{INH}	$0.7 \times V_{DRIVE}$			V	$V_{IN} = 0 \text{ V or } V_{DRIVE}$
Input Low Voltage, V_{INL}			0.8	V	
Input Current, I_{IN}			± 1	μA	
Input Capacitance, C_{IN}^3		4		pF	
LOGIC OUTPUTS					
Output High Voltage, V_{OH}	$V_{DRIVE} - 0.2$			V	
Output Low Voltage, V_{OL}			0.4	V	
Floating State Leakage Current			± 1	μA	
Floating State Output Capacitance ³		5		pF	
Output Coding		Twos complement			
CONVERSION RATE					
Conversion Time			$19 \times t_{SCLK}$	ns	AD7262 AD7262-5
Track-and-Hold Acquisition Time	400			ns	
Throughput Rate			1 500	MSPS KSPS	
COMPARATORS					
Input Offset					$T_A = 25^\circ\text{C to } 105^\circ\text{C only}$
Comparator A and Comparator B		± 2	± 4	mV	
Comparator C and Comparator D		± 2	± 4	mV	
Offset Voltage Drift		0.5		$\mu\text{V}/^\circ\text{C}$	All comparators
Input Common-Mode Range ³		0 to 4		V	$C_{A_CB} V_{CC} = 5 \text{ V}$
		0 to 1.7		V	$C_{A_CB} V_{CC} = 2.7 \text{ V}$
Input Capacitance ³		4		pF	25 pF load, $C_{OUTX} = 0 \text{ V}$, $V_{CM} = AV_{CC}/2$, $V_{OVERDRIVE} = 200 \text{ mV differential}$
Input Impedance ³		1		G Ω	
I_{DD} Normal Mode (Static) ⁶					
Comparator A and Comparator B		3		μA	
		6	8.5	μA	
Comparator C and Comparator D		60		μA	
		120	170	μA	
Propagation Delay Time					
High to Low, t_{PHL}					
Comparator A and Comparator B		1.4	3.5	μs	
		0.95		μs	
Comparator C and Comparator D		0.20	0.32	μs	
		0.13		μs	
Low to High, t_{PLH}					
Comparator A and Comparator B		2	4	μs	
		0.93		μs	
Comparator C and Comparator D		0.18	0.28	μs	
		0.12		μs	
Delay Matching					
Comparator A and Comparator B		± 250		ns	
Comparator C and Comparator D		± 10		ns	

Parameter	Min	Typ	Max	Unit	Test Conditions/Comments
POWER REQUIREMENTS					Digital inputs = 0 V or V_{DRIVE}
$A_{V_{CC}}$	4.75		5.25	V	
$C_A_C_B V_{CC}, C_C_C_D V_{CC}$	2.7		5.25	V	
V_{DRIVE}	2.7		5.25	V	
I_{DD}					
ADC Normal Mode (Static)		20	31.5	mA	$A_{V_{CC}} = 5.25$ V
ADC Normal Mode (Dynamic)		23	33.3	mA	$A_{V_{CC}} = 5.25$ V
Shutdown Mode		0.5	1	μ A	$A_{V_{CC}} = 5.25$ V, ADCs and comparators powered down
Power Dissipation					
ADC Normal Mode (Static)		105	165	mW	
ADC Normal Mode (Dynamic)		120	175	mW	
Shutdown Mode		2.625	5.25	μ W	

¹ These specifications were determined without the use of the gain calibration feature.

² See the Terminology section.

³ Samples tested during initial release to ensure compliance; they are not subject to production testing.

⁴ For PGA gain = 1; to use the full analog input range ($V_{CM} \pm V_{REF}/2$) of the AD7262, the V_{CM} voltage should be dropped to lie within a range from 1.95 V to 2.05 V.

⁵ Refers to Pin V_{REFA} or Pin V_{REFB} .

⁶ This specification includes the I_{DD} for both comparators. The I_{DD} per comparator is the specified value divided by two.

TIMING SPECIFICATIONS

$AV_{CC} = 4.75\text{ V to }5.25\text{ V}$, $C_{A_CB}V_{CC} = C_{C_CD}V_{CC} = 2.7\text{ V to }5.25\text{ V}$, $V_{REF} = 2.5\text{ V}$ internal/external; $T_A = T_{MIN}$ to T_{MAX} , unless otherwise noted.¹

Table 2.

Parameter	Limit at T_{MIN} , T_{MAX}		Unit	Description
	$2.7\text{ V} \leq V_{DRIVE} \leq 3.6\text{ V}$	$4.75\text{ V} \leq V_{DRIVE} \leq 5.25\text{ V}$		
f_{SCLK}	200	200	kHz min	AD7262 ² AD7262 ² AD7262-5
	40	40	MHz max	
	32	32	MHz typ	
	20	20	MHz max	
$t_{CONVERT}$	$19 \times t_{SCLK}$	$19 \times t_{SCLK}$	ns max	$t_{SCLK} = 1/f_{SCLK}$
	475	475	ns max	AD7262
	950	950	ns max	AD7262-5
t_{QUIET}	13	13	ns min	Minimum time between end of serial read/bus relinquish and next falling edge of \overline{CS}
t_2	10	10	ns min	\overline{CS} to SCLK setup time
t_3^3	15	15	ns max	Delay from 19 th SCLK falling edge until D_{OUTA} and D_{OUTB} are three-state disabled
t_4	29	23	ns max	Data access time after SCLK falling edge
t_5	15	13	ns min	SCLK to data valid hold time
t_6	$0.4 \times t_{SCLK}$	$0.4 \times t_{SCLK}$	ns min	SCLK high pulse width
t_7	$0.4 \times t_{SCLK}$	$0.4 \times t_{SCLK}$	ns min	SCLK low pulse width
t_8	13	13	ns min	\overline{CS} rising edge to falling edge pulse width
t_9	13	13	ns max	\overline{CS} rising edge to D_{OUTA} , D_{OUTB} , high impedance/bus relinquish
t_{10}	5	5	ns min	SCLK falling edge to D_{OUTA} , D_{OUTB} , high impedance
	35	35	ns max	SCLK falling edge to D_{OUTA} , D_{OUTB} , high impedance
t_{11}	2	2	μs min	Minimum CAL pin high time
t_{12}	2	2	μs min	Minimum time between the CAL pin high and the \overline{CS} falling edge
t_{13}	3	3	ns min	D_{IN} setup time prior to SCLK falling edge
t_{14}	3	3	ns min	D_{IN} hold time after SCLK falling edge
$t_{POWER-UP}$	240	240	μs max	Internal reference, with a $1\text{ }\mu\text{F}$ decoupling capacitor
	15	15	μs max	With an external reference, $10\text{ }\mu\text{s}$ typical

¹ Sample tested during initial release to ensure compliance. All input signals are specified with $t_R = t_F = 5\text{ ns}$ (10% to 90% of AV_{CC}) and timed from a voltage level of 1.6 V. All timing specifications given are with a 25 pF load capacitance. With a load capacitance greater than this value, a digital buffer or latch must be used. See the Terminology section.

² See the Serial Interface section.

³ The time required for the output to cross 0.4 V or 2.4 V.

TIMING DIAGRAM

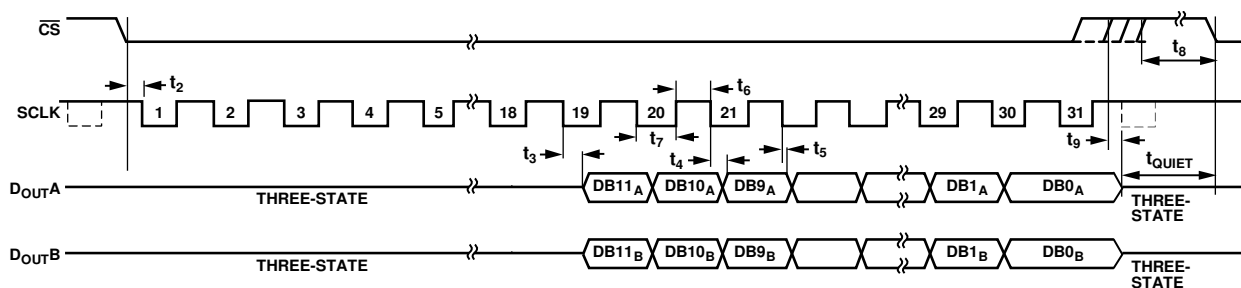

Figure 2. Serial Interface Timing Diagram

07606-002

ABSOLUTE MAXIMUM RATINGS

Table 3.

Parameter	Rating
V _{DRIVE} to DGND	−0.3 V to AV _{CC}
V _{DRIVE} to AGND	−0.3 V to AV _{CC}
AV _{CC} to AGND/DGND	−0.3 V to +7 V
C _A _C _B V _{CC} to C _A _C _B _GND	−0.3 V to +7 V
C _C _C _D V _{CC} to C _C _C _D _GND	−0.3 V to +7 V
AGND to DGND	−0.3 V to +0.3 V
C _A _C _B _GND/C _C _C _D _GND to DGND	−0.3 V to +0.3 V
Analog Input Voltage to AGND	−0.3 V to AV _{CC} + 0.3 V
Digital Input Voltage to DGND	−0.3 V to +7 V
Digital Output Voltage to GND	−0.3 V to V _{DRIVE} + 0.3 V
V _{REFA} /V _{REFB} Input to AGND	−0.3 V to AV _{CC} + 0.3 V
C _{OUTA} /C _{OUTB} /C _{OUTC} /C _{OUTD} to GND	−0.3 V to V _{DRIVE} + 0.3 V
C _A ±/C _B ±/C _C ±/ C _D ± to C _A _C _B _GND/C _C _C _D _GND	−0.3 V to C _A _C _B V _{CC} /C _C _C _D V _{CC} + 0.3 V
Operating Temperature Range	−40°C to +105°C
Storage Temperature Range	−65°C to +150°C
Junction Temperature	150°C
LFCSP	
θ _{JA} Thermal Impedance	30°C/W
θ _{JC} Thermal Impedance	3°C/W
LQFP	
θ _{JA} Thermal Impedance	55°C/W
θ _{JC} Thermal Impedance	16°C/W
Pb-Free Temperature, Soldering	
Reflow	255°C
ESD	2 kV

Stresses at or above those listed under Absolute Maximum Ratings may cause permanent damage to the product. This is a stress rating only; functional operation of the product at these or any other conditions above those indicated in the operational section of this specification is not implied. Operation beyond the maximum operating conditions for extended periods may affect product reliability.

ESD CAUTION



ESD (electrostatic discharge) sensitive device. Charged devices and circuit boards can discharge without detection. Although this product features patented or proprietary protection circuitry, damage may occur on devices subjected to high energy ESD. Therefore, proper ESD precautions should be taken to avoid performance degradation or loss of functionality.

PIN CONFIGURATIONS AND FUNCTION DESCRIPTIONS

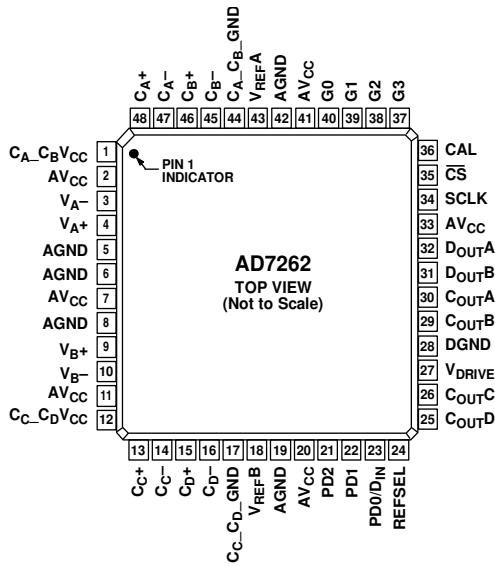
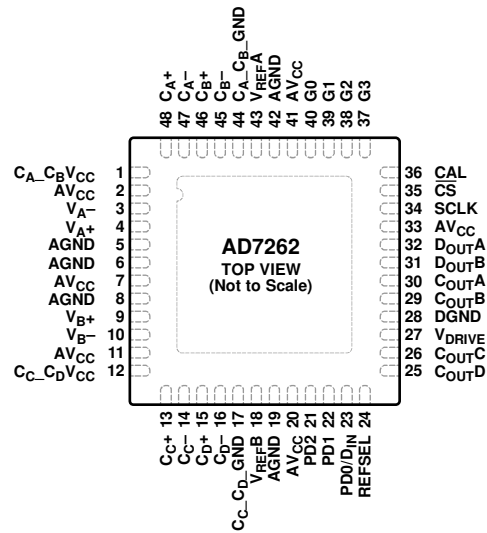

Figure 3. 48-Lead LQFP Pin Configuration



NOTES
 1. THE EXPOSED METAL PADDLE ON THE BOTTOM OF THE LFCSP PACKAGE MUST BE SOLDERED TO PCB GROUND FOR PROPER HEAT DISSIPATION AND ALSO FOR NOISE AND MECHANICAL STRENGTH BENEFITS.

Figure 4. 48-Lead LFCSP Pin Configuration

Table 4. Pin Function Descriptions

Pin No.	Mnemonic	Description
2, 7, 11, 20, 33, 41	AVCC	Analog Supply Voltage, 4.75 V to 5.25 V. This is the supply voltage for the analog circuitry on the AD7262/AD7262-5. All AVCC pins can be tied together. Decouple this supply to AGND with a 100 nF ceramic capacitor per supply and a 10 μF tantalum capacitor.
1	CA_CBVCC	Comparator Supply Voltage, 2.7 V to 5.25 V. This is the supply voltage for Comparator A and Comparator B. Decouple this supply to CA_CB_GND. AVCC, CC_CDVCC, and CA_CBVCC can be tied together.
12	CC_CDVCC	Comparator Supply Voltage, 2.7 V to 5.25 V. This is the supply voltage for Comparator C and Comparator D. Decouple this supply to CC_CD_GND. AVCC, CC_CDVCC, and CA_CBVCC can be tied together.
4, 3	VA+, VA-	Analog Inputs of ADC A. True differential input pair.
9, 10	VB+, VB-	Analog Inputs of ADC B. True differential input pair.
43, 18	VREFA, VREFB	Reference Input/Output. Decoupling capacitors connect to these pins to decouple the internal reference buffer for each respective ADC. Typically, 1 μF capacitors are required to decouple the reference. Provided the output is buffered, the on-chip reference can be taken from these pins and applied externally to the rest of a system.
34	SCLK	Serial Clock. Logic input. A serial clock input provides the SCLK for accessing the data from the AD7262/AD7262-5. This clock is also used as the clock source for the conversion process. A minimum of 31 clocks is required to perform the conversion and access the 12-bit result.
36	CAL	Logic Input. Initiates an internal offset calibration.
21	PD2	Logic Input. Places the AD7262/AD7262-5 in selected shutdown mode in conjunction with the PD1 and PD0 pins (see Table 7).
22	PD1	Logic Input. Places the AD7262/AD7262-5 in selected shutdown mode in conjunction with the PD2 and PD0 pins (see Table 7).

Pin No.	Mnemonic	Description
23	PD0/D _{IN}	Logic Input/Data Input. Places the AD7262/AD7262-5 in selected shutdown mode in conjunction with the PD2 and PD1 pins (see Table 7). If all gain selection pins, G0 to G3, are tied low, this pin acts as the data input pin, and all programming is via the control register (see Table 8). Data to be written to the AD7262/AD7262-5 control register is provided on this input and is clocked into the register on the falling edge of SCLK.
35	$\overline{\text{CS}}$	Chip Select. Active low logic input. This input initiates conversions on the AD7262/AD7262-5 .
48, 47, 46, 45	C _{A+} , C _{A-} , C _{B+} , C _{B-}	Comparator Inputs. These pins are the inverting and noninverting analog inputs for Comparator A and Comparator B. These two comparators have very low power consumption.
13, 14, 15, 16	C _{C+} , C _{C-} , C _{D+} , C _{D-}	Comparator Inputs. These pins are the inverting and noninverting analog inputs for Comparator C and Comparator D. This pair of comparators offers very fast propagation delays.
5, 6, 8, 19, 42	AGND	Analog Ground. Ground reference point for all analog circuitry on the AD7262/AD7262-5 . Refer all analog input signals and any external reference signal to this AGND voltage. All AGND pins should connect to the AGND plane of a system. The AGND, DGND, C _{A-CB_GND} , and C _{C-CD_GND} voltages ideally should be at the same potential and must not be more than 0.3 V apart, even on a transient basis. C _{A-CB_GND} and C _{C-CD_GND} can be tied to AGND.
28	DGND	Digital Ground. This is the ground reference point for all digital circuitry on the AD7262/AD7262-5 . Connect the DGND pin to the DGND plane of a system. The DGND and AGND voltages should ideally be at the same potential and must not be more than 0.3 V apart, even on a transient basis.
30, 29, 26, 25	C _{OUTA} , C _{OUTB} , C _{OUTC} , C _{OUTD}	Comparator Outputs. These pins provide a CMOS (push-pull) output from each respective comparator. These are digital output pins with logic levels determined by the V _{DRIVE} supply.
32, 31	D _{OUTA} , D _{OUTB}	Serial Data Outputs. The data output from the AD7262/AD7262-5 is supplied to each pin as a serial data stream in twos complement format. The bits are clocked out on the falling edge of the SCLK input. A total of 31 SCLKs is required to perform the conversion and access the 12-bit data. During the conversion process, the data output pins are in three-state and, when the conversion is completed, the 19 th SCLK edge clocks out the MSB. The data simultaneously appears on both pins from the simultaneous conversions of both ADCs. The data is provided MSB first. If $\overline{\text{CS}}$ is held low for an additional 14 SCLK cycles on either D _{OUTA} or D _{OUTB} following the initial 31 SCLKs, the data from the other ADC follows on the D _{OUT} pin. This allows data from a simultaneous conversion on both ADCs to be gathered in serial format on either D _{OUTA} or D _{OUTB} using only one serial port.
40, 39, 38, 37	G0, G1, G2, G3	Logic Inputs. These pins program the gain setting of the front-end amplifiers. If all four pins are tied low, the PD0 pin acts as a data input pin, D _{IN} , and all programming is made via the control register (see Table 6).
27	V _{DRIVE}	Logic Power Supply Input, 2.7 V to 5.25 V. The voltage supplied at this pin determines at what voltage the interface operates, including the comparator outputs. Decouple this pin to DGND.
44, 17	C _{A-CB_GND} , C _{C-CD_GND}	Comparator Ground. This is the ground reference point for all comparator circuitry on the AD7262/AD7262-5 . Both the C _{A-CB_GND} pin and the C _{C-CD_GND} pin must connect to the GND plane of a system and can be tied to AGND. The DGND, AGND, C _{A-CB_GND} , and C _{C-CD_GND} voltages should ideally be at the same potential and must not be more than 0.3 V apart, even on a transient basis.
24	REFSEL	Internal/External Reference Selection. Logic input. If this pin is tied to a logic high voltage, the on-chip 2.5 V reference is used as the reference source for both ADC A and ADC B. If the REFSEL pin is tied to GND, an external reference can be supplied to the AD7262/AD7262-5 through the V _{REFA} and/or V _{REFB} pin.
	EPAD	Exposed Metal Paddle. The exposed metal paddle on the bottom of the LFCSP package must be soldered to PCB ground for proper heat dissipation and also for noise and mechanical strength benefits.

TYPICAL PERFORMANCE CHARACTERISTICS

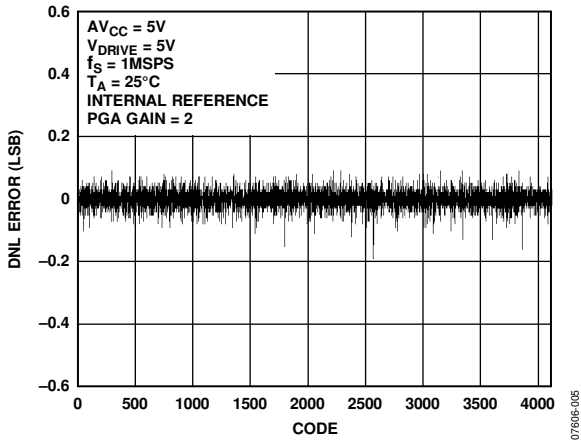

Figure 5. Typical DNL at Gain of 2

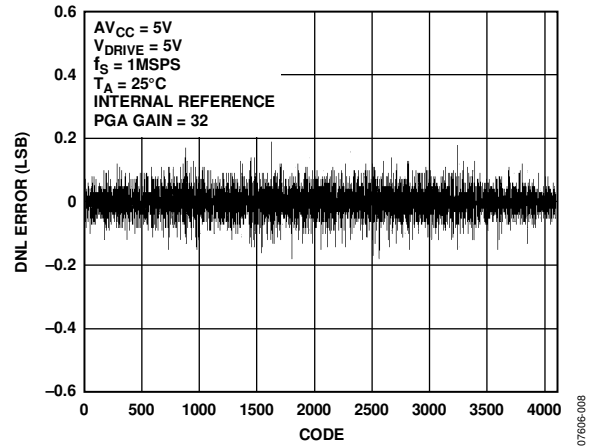

Figure 8. Typical DNL at Gain of 32

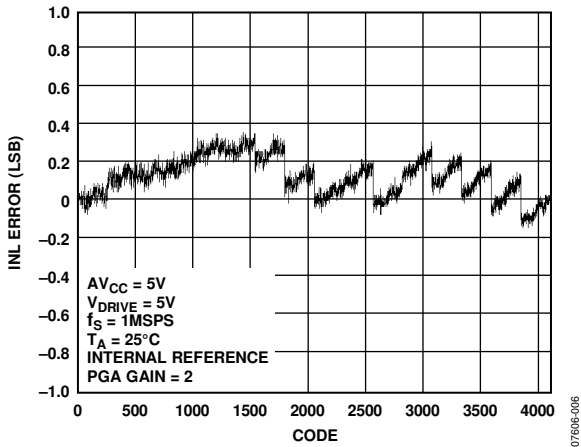

Figure 6. Typical INL at Gain of 2

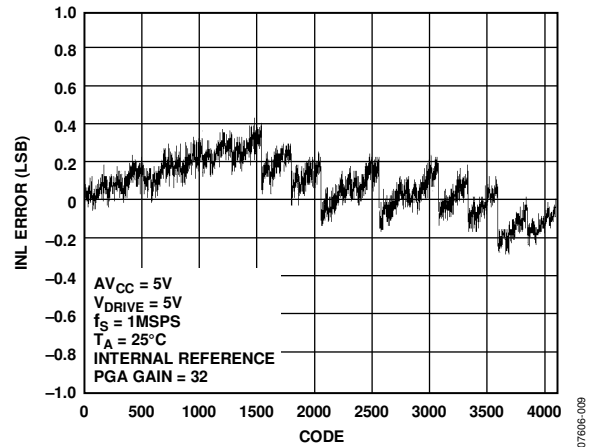

Figure 9. Typical INL at Gain of 32

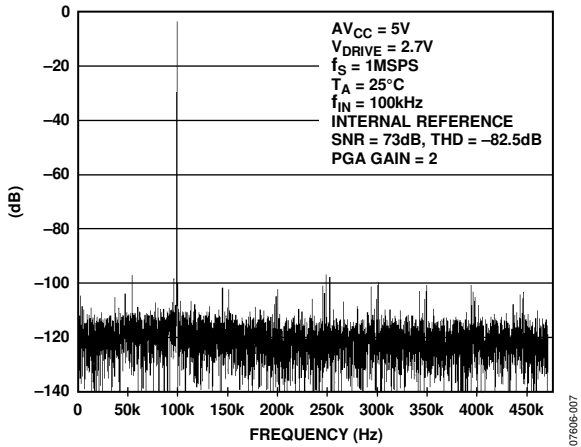

Figure 7. 3 dB Typical FFT at Gain of 2

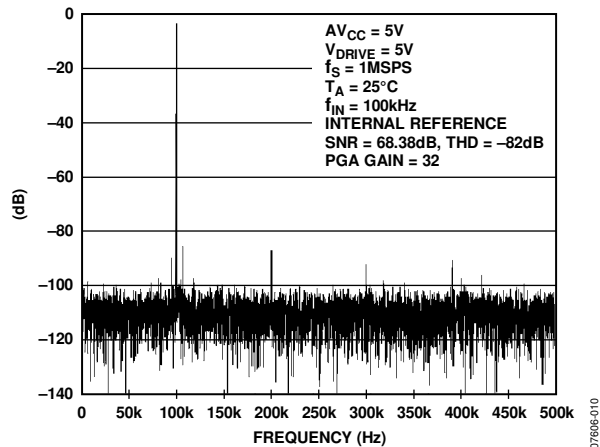

Figure 10. Typical FFT at Gain of 32

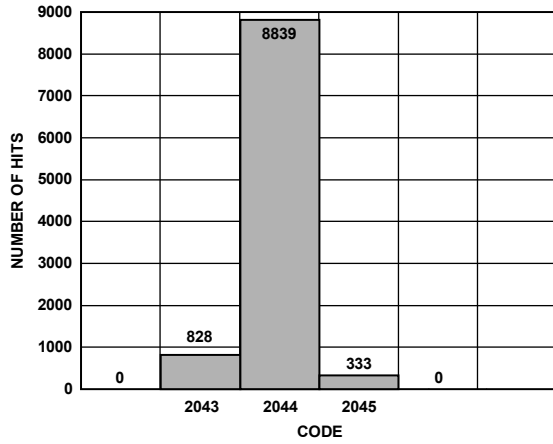

Figure 11. Histogram of Codes for 10k Samples at Gain of 2

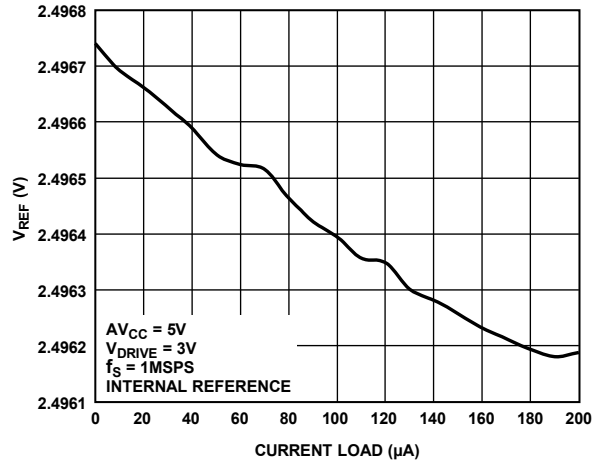

Figure 14. V_{REF} vs. Reference Output Current Load

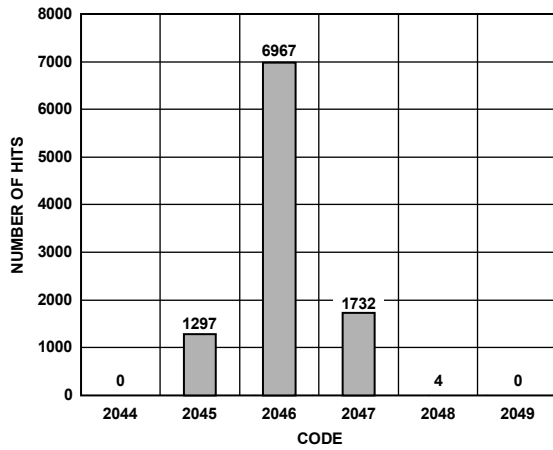

Figure 12. Histogram of Codes for 10k Samples at Gain of 32

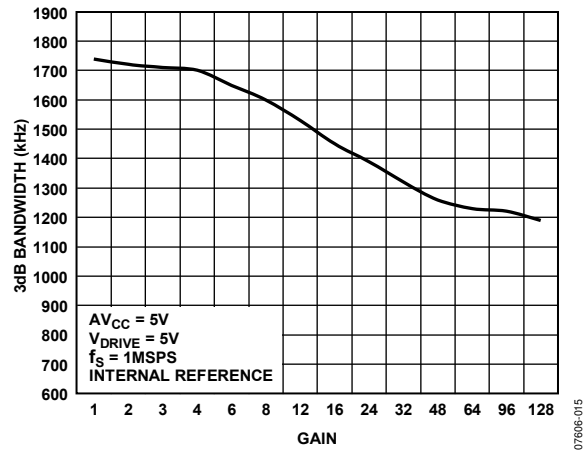

Figure 15. 3 dB Bandwidth vs. Gain

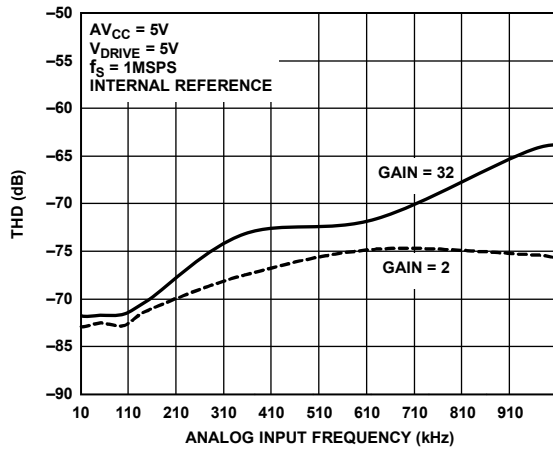

Figure 13. THD vs. Analog Input Frequency up to 1 MHz at Gain of 2 and 32

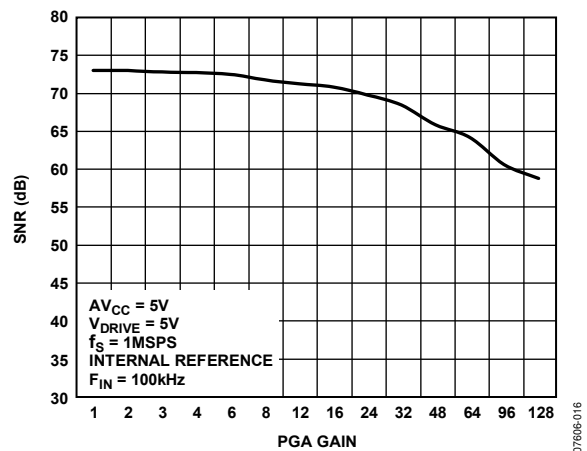

Figure 16. SNR vs. PGA Gain for an Analog Input Tone of 100 kHz

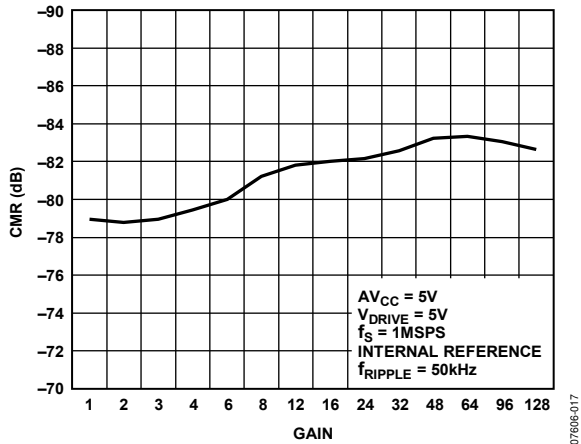

Figure 17. Common-Mode Rejection vs. Gain

07606-017

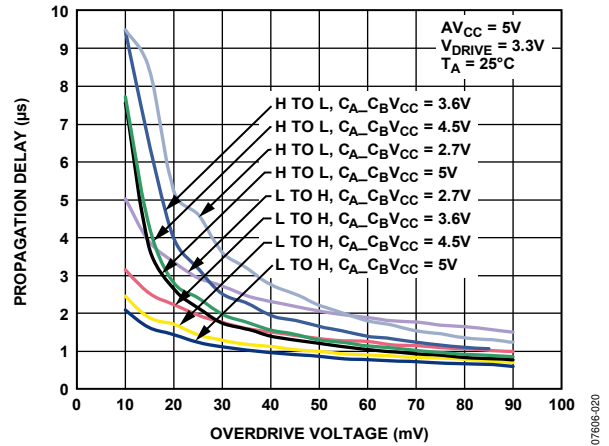

Figure 20. Propagation Delay for Comparator A and Comparator B vs. Overdrive Voltage for Various Supply Voltages

07606-020

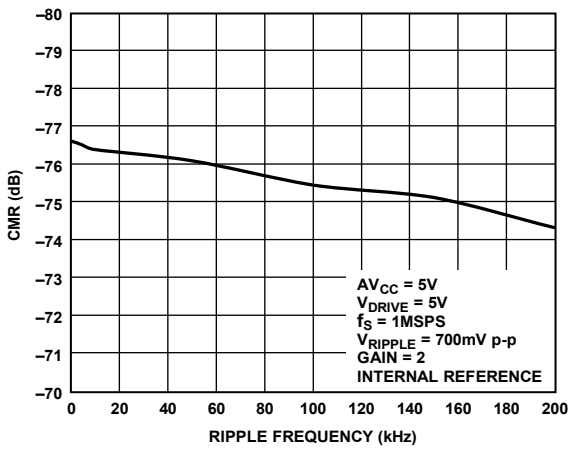

Figure 18. Common-Mode Rejection vs. Common-Mode Ripple Frequency

07606-018

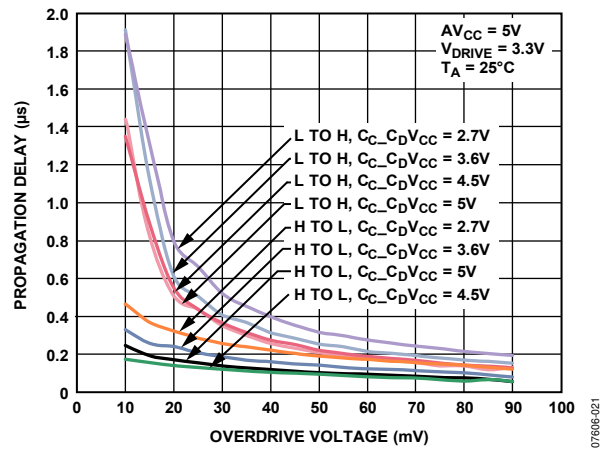

Figure 21. Propagation Delay for Comparator C and Comparator D vs. Overdrive Voltage for Various Supply Voltages

07606-021

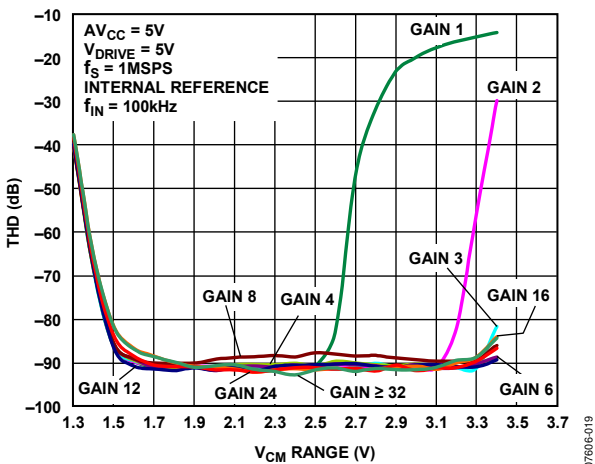

Figure 19. THD vs. Common-Mode Range for Various PGA Gain Settings

07606-019

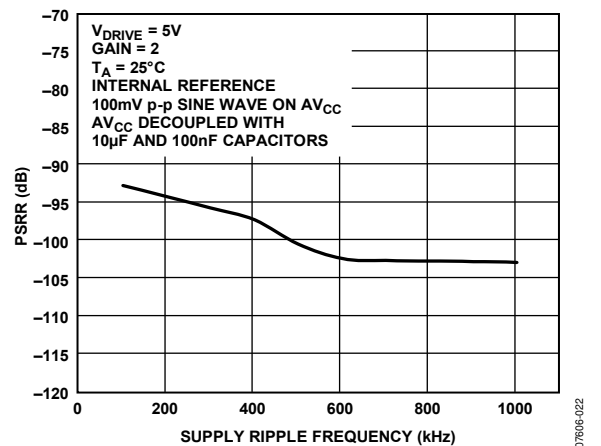

Figure 22. Power Supply Rejection Ratio vs. Supply Ripple Frequency?

07606-022

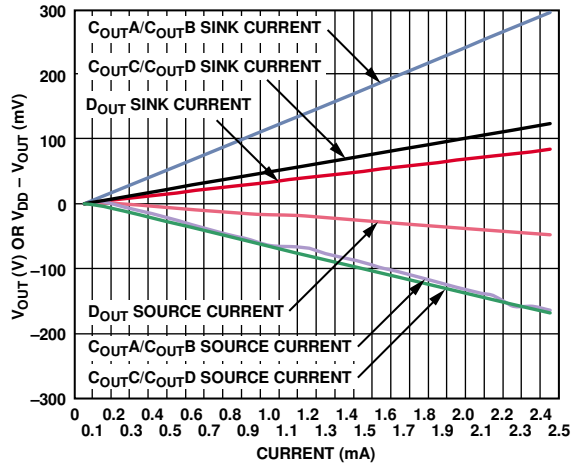

Figure 23. D_{OUT} and C_{OUT} Source and Sink Current

TERMINOLOGY

Differential Nonlinearity (DNL)

Differential nonlinearity is the difference between the measured and the ideal 1 LSB change between any two adjacent codes in the ADC.

Integral Nonlinearity (INL)

Integral nonlinearity is the maximum deviation from a straight line passing through the endpoints of the ADC transfer function. The endpoints of the transfer function are zero scale, a single (1) LSB point below the first code transition, and full scale, a single (1) LSB point above the last code transition.

Zero Code Error

This is the deviation of the midscale transition (all 1s to all 0s) from the ideal V_{IN} voltage, that is, $V_{CM} - \frac{1}{2}$ LSB.

Positive Full-Scale Error

This is the deviation of the last code transition (011 ... 110) to (011 ... 111) from the ideal, that is,

$$V_{CM} + \left(\frac{V_{REF}}{2 \times Gain} \right) - 1 \text{ LSB}$$

after the zero code error has been adjusted out.

Negative Full-Scale Error

This is the deviation of the first code transition (10 ... 000) to (10 ... 001) from the ideal, that is,

$$V_{CM} - \left(\frac{V_{REF}}{2 \times Gain} \right) + 1 \text{ LSB}$$

after the zero code error has been adjusted out.

Zero Code Error Match

This is the difference in zero code error across both ADCs.

Positive Full-Scale Error Match

This is the difference in positive full-scale error across both ADCs.

Negative Full-Scale Error Match

This is the difference in negative full-scale error across both ADCs.

Track-and-Hold Acquisition Time

The track-and-hold amplifier returns to track mode at the end of a conversion. Track-and-hold acquisition time is the time required for the output of the track-and-hold amplifier to reach its final value, within $\pm 1/2$ LSB, after the end of a conversion.

Signal-to-(Noise + Distortion) Ratio

This ratio is the measured ratio of signal-to-(noise + distortion) at the output of the analog-to-digital converter. The signal is the rms amplitude of the fundamental. Noise is the sum of all non-fundamental signals up to half the sampling frequency ($f_S/2$), excluding dc. The ratio is dependent on the number of quantization levels in the digitization process; the more levels, the smaller the quantization noise.

The theoretical signal-to-(noise + distortion) ratio for an ideal N-bit converter with a sine wave input is given by

$$\text{Signal-to-(Noise + Distortion)} = (6.02N + 1.76) \text{ dB}$$

Thus for a 12-bit converter, this is 86 dB.

Total Harmonic Distortion (THD)

Total harmonic distortion is the ratio of the rms sum of harmonics to the fundamental. For the AD7262/AD7262-5, it is defined as

$$\text{THD(dB)} = 20 \log \frac{\sqrt{V_2^2 + V_3^2 + V_4^2 + V_5^2 + V_6^2}}{V_1}$$

where V_1 is the rms amplitude of the fundamental, and V_2 , V_3 , V_4 , V_5 , and V_6 are the rms amplitudes of the second through the sixth harmonics.

Peak Harmonic or Spurious Noise

Peak harmonic, or spurious noise, is defined as the ratio of the rms value of the next largest component in the ADC output spectrum (up to $f_S/2$, excluding dc) to the rms value of the fundamental. Normally, the value of this specification is determined by the largest harmonic in the spectrum, but for ADCs where the harmonics are buried in the noise floor, it is a noise peak.

ADC-to-ADC Isolation

ADC-to-ADC isolation is a measure of the level of crosstalk between the ADC A and ADC B. It is measured by applying a full-scale, 100 kHz sine wave signal to all unselected input channels and determining how much that signal is attenuated in the selected channel with a 40 kHz signal. The figure given is the worst case.

PSRR (Power Supply Rejection)

Variations in power supply affect the full-scale transition but not the linearity of the converter. Power supply rejection is the maximum change in the full-scale transition point due to a change in power supply voltage from the nominal value (see Figure 22).

Propagation Delay Time, Low to High (t_{PLH})

Propagation delay time from low to high is defined as the time taken from the 50% point on a low to high input signal until the digital output signal reaches 50% of its final low value.

Propagation Delay Time, High to Low (t_{PHL})

Propagation delay time from high to low is defined as the time taken from the 50% point on a high to low input signal until the digital output signal reaches 50% of its final high value.

Comparator Offset

Comparator offset is the measure of the density of digital 1s and 0s in the comparator output when the negative analog terminal of the comparator input is held at a static potential and the analog input to the positive terminal of the comparators is varied proportionally about the static negative terminal voltage.

THEORY OF OPERATION

CIRCUIT INFORMATION

The AD7262/AD7262-5 are fast, dual, simultaneous sampling, differential, 12-bit, serial ADCs. The AD7262/AD7262-5 contain two on-chip differential programmable gain amplifiers, two track-and-hold amplifiers, and two successive approximation analog-to-digital converters with a serial interface with two separate data output pins. The AD7262/AD7262-5 also include four on-chip comparators. They are housed in a 48-lead LFCSP and in a 48-lead LQFP, offering the user considerable space-saving advantages over alternative solutions. The AD7262/AD7262-5 require a low voltage $5\text{ V} \pm 5\%$ V_{CC} to power the ADC core and supply the digital power, a 5.25 V to 2.7 V $C_{A_CB}V_{CC}$, $C_{C_CD}V_{CC}$ supply for the comparators, and a 2.7 V to 5.25 V V_{DRIVE} supply for interface power.

The on-board PGA allows the user to select from 14 programmable gain stages: $\times 1$, $\times 2$, $\times 3$, $\times 4$, $\times 6$, $\times 8$, $\times 12$, $\times 16$, $\times 24$, $\times 32$, $\times 48$, $\times 64$, $\times 96$, and $\times 128$. The PGA accepts fully differential analog signals. The gain can be selected either by setting the logic state of the G0 to G3 pins or by programming the control register.

The serial clock input accesses data from the part while also providing the clock source for each successive approximation ADC. The AD7262/AD7262-5 have an on-chip 2.5 V reference that can be disabled when an external reference is preferred. If the internal reference is used elsewhere in a system, the output from V_{REFA} and V_{REFB} must first be buffered. If the internal reference is the preferred option, the user must tie the REFSEL pin to a logic high voltage. Alternatively, if the REFSEL pin is tied to GND, an external reference can be supplied to both ADCs through the V_{REFA} and V_{REFB} pins (see the Reference section).

The AD7262/AD7262-5 also feature a range of power-down options to allow the user great flexibility with the independent circuit components while allowing for power savings between conversions. The power-down feature is implemented via the control register or the PD0 to PD2 pins, as described in the Control Register section.

COMPARATORS

The AD7262/AD7262-5 have four on-chip comparators. Comparator A and Comparator B have ultralow power consumption, with static power consumption typically less than $10\text{ }\mu\text{W}$ with a 3.3 V supply. Comparator C and Comparator D feature very fast propagation delays of 130 ns for a 200 mV differential overdrive. These comparators have push-pull output stages that operate from the V_{DRIVE} supply. This feature allows operation with a minimum amount of power consumption.

Each pair of comparators operates from its own independent supply, $C_{A_CB}V_{CC}$ and $C_{C_CD}V_{CC}$. The comparators are specified for supply voltages from 2.7 V to 5.25 V . If desired, $C_{A_CB}V_{CC}$ and $C_{C_CD}V_{CC}$ can be tied to the AV_{CC} supply. The four comparators on the AD7262/AD7262-5 are functional with $C_{A_CB}V_{CC}/C_{C_CD}V_{CC}$ greater than or equal to 1.8 V . However, no specifications are guaranteed for comparator supplies less than 2.7 V . The wide range of supply voltages ensures that the comparators can be used in a variety of battery backup modes.

The four on-chip comparators on the AD7262/AD7262-5 are ideally suited for monitoring signals from pole sensors in motor control systems. The comparators can be used to monitor signals from Hall effect sensors or the inner tracks from an optical encoder. One of the comparators can be used to count the index marker or z marker, which is used on startup to place the motor in a known position.

OPERATION

The AD7262/AD7262-5 have two successive approximation ADCs, each based around two capacitive DACs and two programmable gate amplifiers.

The ADC itself comprises control logic, a SAR, and two capacitive DACs. The control logic and the charge redistribution DACs are used to add and subtract fixed amounts of charge from the sampling capacitor amplifiers to bring the comparator back into a balanced condition. When the comparator is rebalanced, the conversion is complete. The control logic generates the ADC output code.

Each ADC is preceded by its own programmable gain stage. The PGA features high analog input impedance, true differential analog inputs that allow the output from any source or sensor to be connected directly to the PGA inputs without any requirement for additional external buffering. The variable gain settings ensure that the device can be used for amplifying signals from a variety of sources. The AD7262/AD7262-5 offer the flexibility to choose the most appropriate gain setting to use the wide dynamic range of the device.

ANALOG INPUTS

Each ADC in the AD7262/AD7262-5 has two high impedance differential analog inputs. Figure 24 shows the equivalent circuit of the analog input structure of the AD7262/AD7262-5. It consists of a fully differential input amplifier that buffers the analog input signal and provides the gain selected by using the gain pins or the control register.

The two diodes provide ESD protection. Care must be taken to ensure that the analog input signals never exceed the supply rails by more than 300 mV. Exceeding 300 mV causes these diodes to become forward-biased and to start conducting current into the substrate. These diodes can conduct up to 10 mA without causing irreversible damage to the part. The C1 capacitors in Figure 24 are typically 5 pF and can primarily be attributed to pin capacitance.

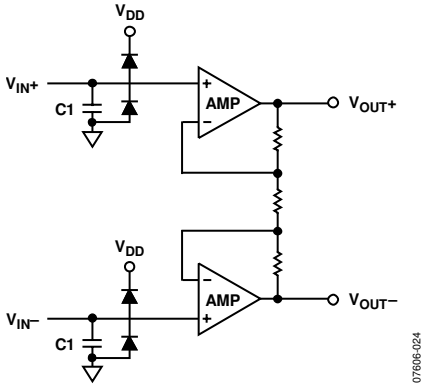

Figure 24. Analog Input Structure

The AD7262/AD7262-5 can accept differential analog inputs from

$$V_{CM} - \left(\frac{V_{REF}}{2 \times Gain} \right) \text{ to } V_{CM} + \left(\frac{V_{REF}}{2 \times Gain} \right)$$

Table 5 details the analog input range for the AD7262/AD7262-5 for the various PGA gain settings. Here, $V_{REF} = 2.5 \text{ V}$ and $V_{CM} = 2.5 \text{ V}$ ($AV_{CC}/2$, with $AV_{CC} = 5 \text{ V}$).

Table 5. Analog Input Range for Various PGA Gain Settings

PGA Gain Setting	Analog Input Range for V_{IN+} and V_{IN-}
1	0.75 V to 3.25 V ¹
2	1.875 V to 3.125 V
3	2.083 V to 2.916 V
4	2.187 V to 2.813 V
6	2.292 V to 2.708 V
8	2.344 V to 2.656 V
12	2.396 V to 2.604 V
16	2.422 V to 2.578 V
24	2.448 V to 2.552 V
32	2.461 V to 2.539 V
48	2.474 V to 2.526 V
64	2.480 V to 2.520 V
96	2.487 V to 2.513 V
128	2.490 V to 2.510 V

¹ For $V_{CM} = 2 \text{ V}$. If $V_{CM} = AV_{CC}/2$, the analog input range for V_{IN+} and V_{IN-} is 1.6 V to 3.4 V.

When a full-scale step input is applied to either differential input on the AD7262/AD7262-5 while the other analog input is held at a constant voltage, 3 μs of settling time is typically required prior to capturing a stable digital output code.

Transfer Function

The AD7262/AD7262-5 output is twos complement, and the ideal transfer characteristic is shown in Figure 25. The designed code transitions occur at successive integer LSB values (that is, 1 LSB, 2 LSB, and so on). The LSB size is dependent on the analog input range selected. The LSB size for the AD7262/AD7262-5 is shown in the following equation:

$$2 \times \left(\frac{\left(V_{CM} + \left(\frac{V_{REF}}{2 \times Gain} \right) \right) - \left(V_{CM} - \left(\frac{V_{REF}}{2 \times Gain} \right) \right)}{4096} \right)$$

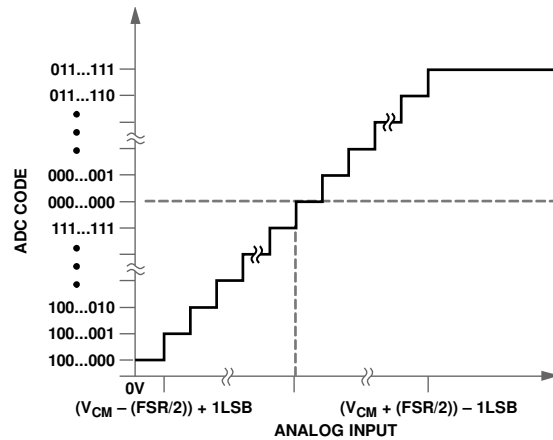

NOTES
1. FULL-SCALE RANGE (FSR) = $V_{IN+} - V_{IN-}$

Figure 25. Twos Complement Transfer Function

V_{DRIVE}

The AD7262/AD7262-5 have a V_{DRIVE} feature to control the voltage at which the serial interface operates. V_{DRIVE} allows the ADC and the comparators to interface easily to both 3 V and 5 V processors. For example, when the AD7262/AD7262-5 are operated with $AV_{CC} = 5 \text{ V}$, the V_{DRIVE} pin can be powered from a 3 V supply, allowing a large analog input range with low voltage digital processors.

REFERENCE

The AD7262/AD7262-5 can operate with either the internal 2.5 V on-chip reference or an externally applied reference. The logic state of the REFSEL pin determines whether the internal reference is used. The internal reference is selected for both ADCs when the REFSEL pin is tied to logic high. If the REFSEL pin is tied to AGND, an external reference can be supplied through the V_{REFA} and/or V_{REFB} pins. On power-up, the REFSEL pin must be tied to either a low or high logic state for the part to operate. Suitable reference sources for the AD7262/AD7262-5 include AD780, AD1582, ADR431, REF193, and ADR391.

The internal reference circuitry consists of a 2.5 V band gap reference and a reference buffer. When the AD7262/AD7262-5 are operated in internal reference mode, the 2.5 V internal reference is available at the V_{REFA} and V_{REFB} pins, which should be decoupled to AGND using a 1 μ F capacitor. It is recommended that the internal reference be buffered before applying it elsewhere in the system. The internal reference is capable of sourcing up to 90 μ A of current when the converter is static. If the internal reference operation is required for the ADC conversion, the REFSEL pin must be tied to logic high on power-up. The reference buffer requires 240 μ s to power up and charge the 1 μ F decoupling capacitor during the power-up time.

TYPICAL CONNECTION DIAGRAMS

Figure 26 and Figure 27 are typical connection diagrams for the AD7262/AD7262-5. In these configurations, the AGND pin is connected to the analog ground plane of the system, and the DGND pin is connected to the digital ground plane of the system. The analog inputs on the AD7262/AD7262-5 are true differential and have an input impedance in excess of 1 G Ω ; thus, no driving op amps are required. The AD7262/AD7262-5 can operate with either an internal or an external reference. In Figure 26, the AD7262/AD7262-5 are configured to operate in control register mode; thus, G0 to G3, PD1, and PD2 can be connected to ground (low logic state). Figure 27 has the gain pins configured for a gain of 2 setup; thus, the device is in pin-driven mode. Both circuit configurations illustrate the use of the internal 2.5 V reference

The $C_{A_C_B}V_{CC}$ and the $C_{C_C_D}V_{CC}$ pins can be connected to either a 3 V or a 5 V supply voltage. The AV_{CC} pin must be connected to a 5 V supply. All supplies should be decoupled with a 100 nF capacitor at the device pin, and some supply sources may require a 10 μ F capacitor where the source is supplied to the circuit board. The V_{DRIVE} pin is connected to the supply voltage of the microprocessor. The voltage applied to the V_{DRIVE} input controls the voltage of the serial interface. V_{DRIVE} can be set to 3 V or 5 V.

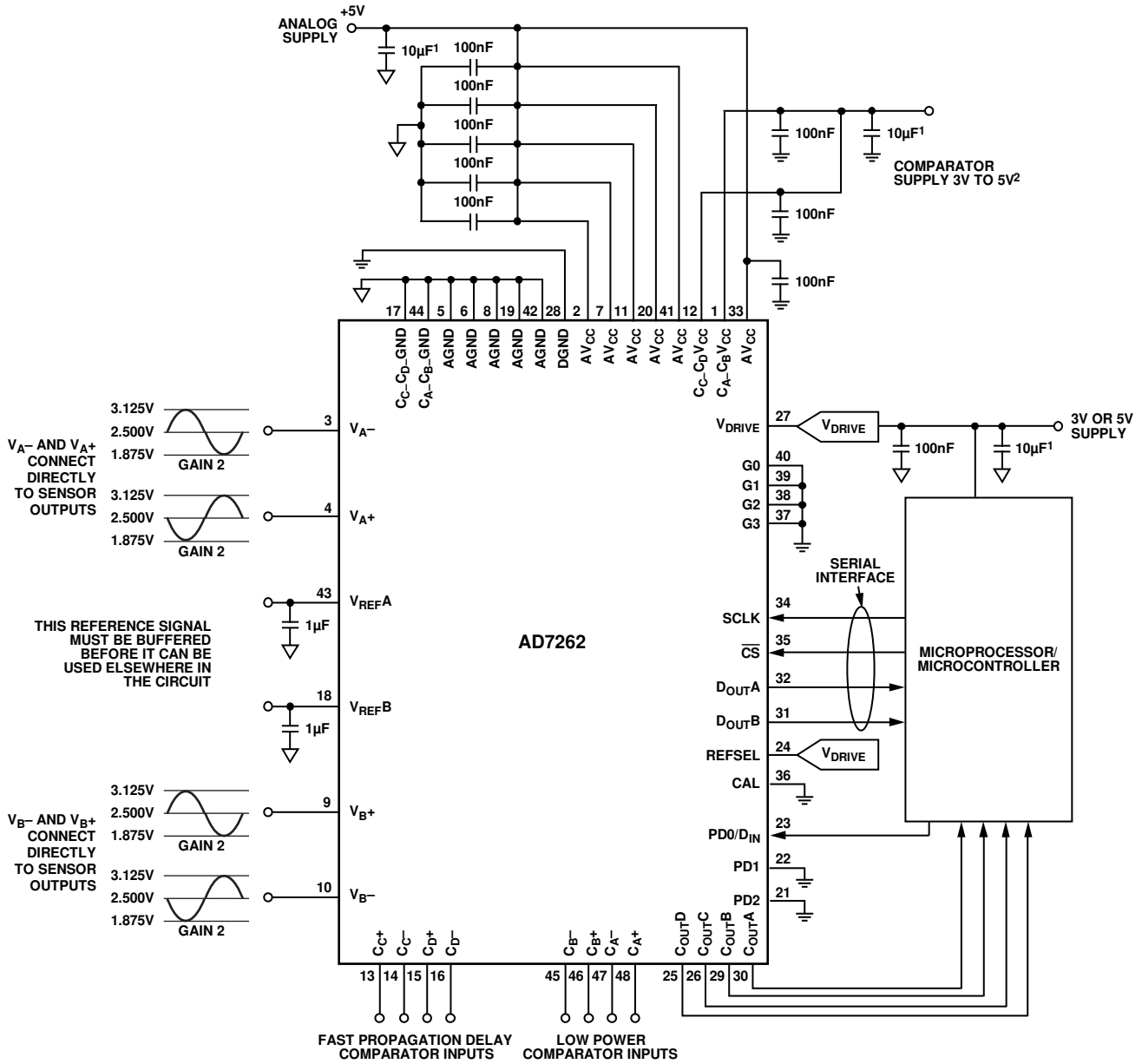

¹THESE CAPACITORS ARE PLACED AT THE SUPPLY SOURCE AND MAY NOT BE REQUIRED IN ALL SYSTEMS.
²THIS SUPPLY CAN BE CONNECTED TO THE ANALOG 5V SUPPLY IF REQUIRED.

Figure 26. Typical Connection Diagram for the AD7262/AD7262-5 in Control Register Mode (All Gain Pins Tied to Ground) Configured for a PGA Gain of 2

07606-026

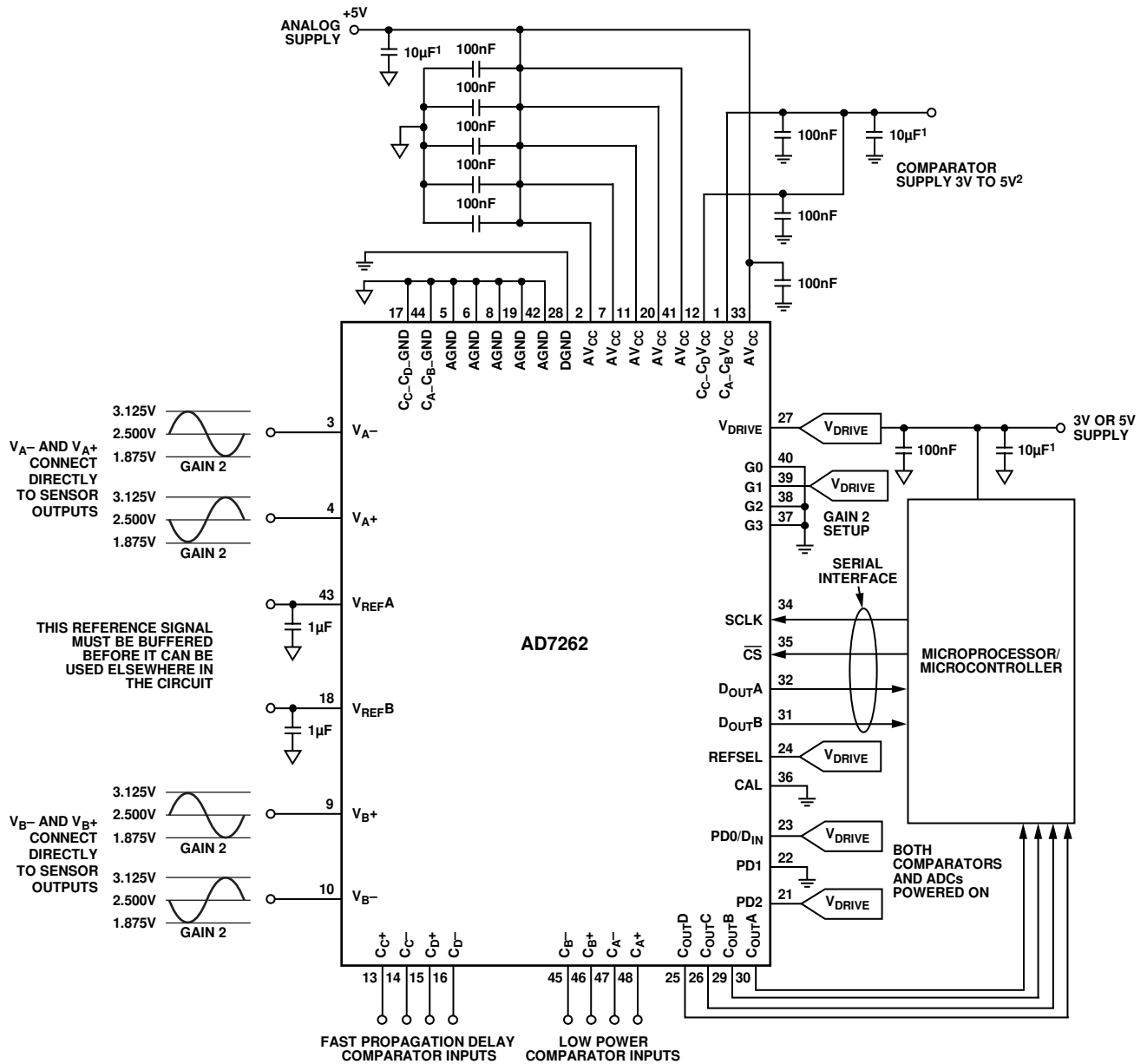

¹THESE CAPACITORS ARE PLACED AT THE SUPPLY SOURCE AND MAY NOT BE REQUIRED IN ALL SYSTEMS.
²THIS SUPPLY CAN BE CONNECTED TO THE ANALOG 5V SUPPLY IF REQUIRED.

Figure 27. Typical Connection Diagram for the AD7262/AD7262-5 in Pin-Driven Mode with Gain of 2 and Both ADCs and Comparators Fully Powered On

07806-027

Comparator Application Details

The comparators on the AD7262/AD7262-5 have been designed with no internal hysteresis, allowing users the flexibility to add external hysteresis if required for systems operating in noisy environments. If the comparators on the AD7262/AD7262-5 are used with external hysteresis, some external resistors and capacitors are required, as shown in Figure 28. The value of R_F and R_S , the external resistors, can be determined using the following equation, depending on the amount of hysteresis required in the application:

$$V_{HYS} = \frac{R_S}{R_S + R_F} \times C_x - C_x V_{CC}$$

where $C_x \times C_x V_{CC} = C_{A_CB} V_{CC}$ or $C_{C_CD} V_{CC}$.

The amount of hysteresis chosen must be sufficient to eliminate the effects of analog noise at the comparator inputs, which may affect the stability of the comparator outputs. The level of hysteresis required in any system depends on the noise in the system; thus, the values of R_F and R_S need to be carefully selected to eliminate any noise effects. To increase the level of hysteresis in the system, increase the value of R_S or R_F . For example, $R_F = 10 \text{ M}\Omega$, $R_S = 1 \text{ k}\Omega$ give $330 \text{ }\mu\text{V}$ of hysteresis with a $C_x \times C_x V_{CC}$ of 3.3 V ; if hysteresis is increased to 1 mV , $R_S = 3.1 \text{ k}\Omega$. In certain applications, a load capacitor (100 pF) may be required on the comparator outputs to suppress high frequency transient glitches.

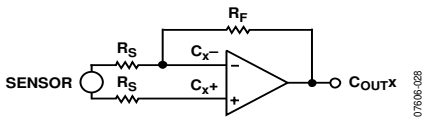

Figure 28. Recommended Comparator Connection Diagram

APPLICATION DETAILS

The AD7262/AD7262-5 have been specifically designed to meet the requirements of any motor control shaft position feedback loop. The devices can interface directly to multiple sensor types, including optical encoders, magneto resistive sensors, and Hall effect sensors. Flexible analog inputs that incorporate program-mable gain ensure that identical board design can be used for a variety of sensors, which results in reduced design cycles and costs.

The two simultaneous sampling ADCs are used to sample the sine and cosine outputs from the sensor. No external buffering is required between the sensor/transducer and the analog inputs of the AD7262/AD7262-5. The on-chip comparators can be used to monitor the pole sensors, which can be Hall effect sensors or the inner tracks from an optical encoder.

Figure 29 shows how the AD7262/AD7262-5 can be used in a typical application. An optical encoder is shown in Figure 29, but other sensor types could as easily be used. Figure 29 indicates a typical application configuration only, and there are several other configurations that render equally effective results.

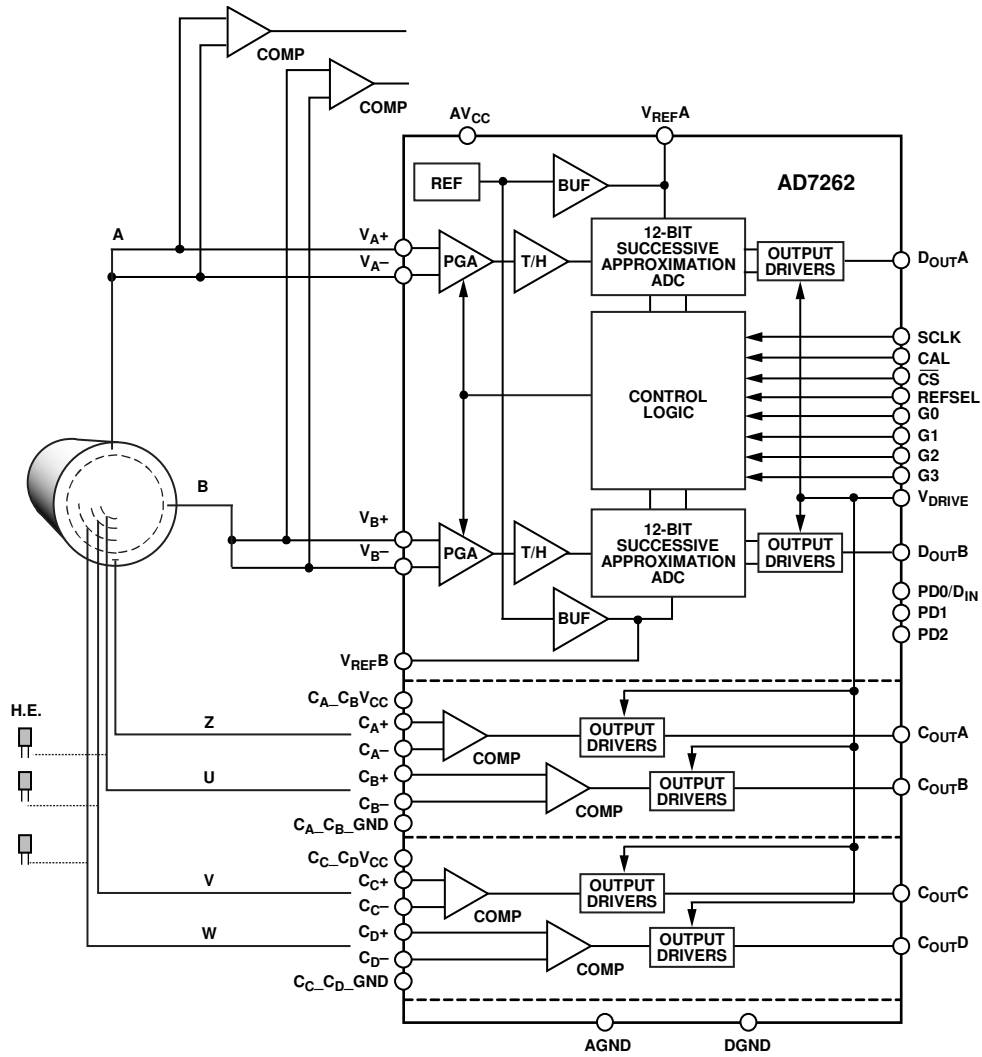

Figure 29. Typical System Connection Diagram with Optical Encoder

07996-029

MODES OF OPERATION

The [AD7262/AD7262-5](#) allow the user to choose between two modes of operation, pin-driven mode and control register mode.

PIN-DRIVEN MODE

In pin-driven mode, the user can select the gain of the PGA, the power-down mode, internal or external reference, and initiate a calibration of the offset for both ADC A and ADC B. These functions are implemented by setting the logic levels on the gain pins (G3 to G0), the power-down pins (PD2 to PD0), the REFSEL pin, and the CAL pin, respectively.

The logic state of Pin G3 to Pin G0 determines which mode of operation is selected. Pin-driven mode is selected if at least one of the gain pins is set to a logic high state. Alternatively, if all four gain pins are connected to a logic low, the control register mode of operation is selected.

GAIN SELECTION

The on-board PGA allows the user to select from 14 programmable gain stages: $\times 1$, $\times 2$, $\times 3$, $\times 4$, $\times 6$, $\times 8$, $\times 12$, $\times 16$, $\times 24$, $\times 32$, $\times 48$, $\times 64$, $\times 96$, and $\times 128$. The PGA accepts fully differential analog signals and provides three key functions, which include selecting gains for small amplitude input signals, driving the ADCs switched capacitive load, and buffering the source from the switching effects of the SAR ADCs. The [AD7262/AD7262-5](#) offer the user great flexibility in user interface, providing gain selection via the control register or by driving the gain pins to the desired logic state. The [AD7262/AD7262-5](#) have four gain pins, G3, G2, G1 and G0, as shown in Figure 3. Each gain setting is selected by setting up the appropriate logic state on each of the four gain pins, as outlined in Table 6. If all four gain pins are connected to a logic low level, the part is put in control register mode and the gain settings are selected via the control register.

Table 6. Gain Selection

G3	G2	G1	G0	Gain
0	0	0	0	Software control via control register
0	0	0	1	1
0	0	1	0	2
0	0	1	1	3
0	1	0	0	4
0	1	0	1	6
0	1	1	0	8
0	1	1	1	12
1	0	0	0	16
1	0	0	1	24
1	0	1	0	32
1	0	1	1	48
1	1	0	0	64
1	1	0	1	96
1	1	1	0	128

POWER-DOWN MODES

The [AD7262/AD7262-5](#) offer the user a number of power-down options to enable individual device components to be powered down independently. These options can be chosen to optimize the power dissipation for different application requirements. The power-down modes can be selected by either programming the device via the control register or by driving the PD pins to the appropriate logic levels. By setting the PD pins to a logic low level when in pin-driven mode, all four comparators and both ADCs can be powered down. The PD2 and PD0 pins must be set to logic high and the PD1 pin set to logic low to power up all circuitry on the [AD7262/AD7262-5](#). The PD pin configurations for the various power-down options are outlined in Table 7.

Table 7. Power-Down Modes

PD2	PD1	PD0	Comparator A, Comparator B	Comparator C, Comparator D	ADC A, ADC B
0	0	0	Off	Off	Off
0	0	1	Off	Off	On
0	1	0	Off	On	Off
0	1	1	On	Off	Off
1	0	0	On	On	Off
1	0	1	On	On	On
1 ¹	1 ¹	1 ¹	Off	Off	Off

¹ PD2 = PD1 = PD0 = 1 resets the [AD7262/AD7262-5](#) when in pin-driven mode only.

The AV_{CC} and V_{DRIVE} supplies must continue to be supplied to the [AD7262/AD7262-5](#) when the comparators are powered up but the ADCs are powered-down. External diodes can be used from the $C_{A_CB}V_{CC}/C_{C_CD}V_{CC}$ to both the AV_{CC} and the V_{DRIVE} supplies to ensure they retain a supply at all instances.

The [AD7262/AD7262-5](#) can be reset in pin-driven mode only by setting the PDx pins to a logic high state. When the device is reset, all the registers are cleared and the four comparators and the two ADCs are left powered down.

In normal mode of operation with the ADCs and comparators powered on, the $C_{A_CB}V_{CC}/C_{C_CD}V_{CC}$ supply and the AV_{CC} supply can be at different voltage levels, as indicated in Table 1. When the comparators on the [AD7262/AD7262-5](#) are in power-down mode, and the $C_{A_CB}V_{CC}/C_{C_CD}V_{CC}$ supplies are at a potential 0.3 V greater than or less than the AV_{CC} supply, the supplies consume more current than would be the case if both sets of supplies were at the same potential. This configuration does not damage the [AD7262/AD7262-5](#) but results in additional current flowing in any or all of the [AD7262/AD7262-5](#) supply pins. This is due to ESD protection diodes within the device. In applications where power consumption in power-down mode is critical, it is recommended that the $C_{A_CB}V_{CC}/C_{C_CD}V_{CC}$ supply and the AV_{CC} supply be held at the same potential.

Power-Up Conditions

On power-up, the status of the gain pins determine which mode of operation is selected, as outlined in the Gain Selection section. All registers are set to 0 by default.

If the AD7262/AD7262-5 are powered up in pin-driven mode, the gain pins and the PDx pins should be configured to the appropriate logic states and a calibration initiated if required.

Alternatively, if the AD7262/AD7262-5 are powered up in control register mode, the comparators and ADCs are powered down and the default gain is 1. Thus, powering up in control register mode requires a write to the device to power up the comparators and the ADCs.

It takes 15 μ s to power up the AD7262/AD7262-5 when using an external reference. When the internal reference is used, 240 μ s are required to power up the AD7262/AD7262-5 with a 1 μ F decoupling capacitor.

CONTROL REGISTER

The control register on the AD7262/AD7262-5 is a 12-bit read and write register, which is used to control the device when not in pin-driven mode. The PD0/D_{IN} pin serves as the serial D_{IN} pin for the AD7262/AD7262-5 when the gain pins are set to 0 (that is, the part is not in pin-driven mode). The control register can be used to select the gain of the PGAs, the power-down modes, and the calibration of the offset for both ADC A and ADC B. When operating in the control register mode, PD1 and PD2 should be connected to a low logic state.

These functions can also be implemented by setting the logic levels on the gain pins, the power-down pins, and the CAL pin, respectively. The control register can also be used to read the offset and gain registers.

Data is loaded from the PD0/D_{IN} pin of the AD7262/AD7262-5 on the falling edge of SCLK when \overline{CS} is in a logic low state. The control register is selected by first writing the appropriate four WR bits, as outlined in Table 10. The 12 data bits must then be clocked into the control register of the device. Thus, on the 16th falling SCLK edge, the LSB is clocked into the device. One more SCLK cycle is then required to write to the internal device registers. In total, 17 SCLK cycles are required to successfully write to the AD7262/AD7262-5. The data is transferred on the PD0/D_{IN} line while the conversion result is being processed. The data transferred on the D_{IN} line corresponds to the AD7262/AD7262-5 configuration for the next conversion.

Only the information provided on the 12 falling clock edges after the \overline{CS} falling edge and the initial four write address bits is loaded to the control register. The PD0/D_{IN} pin should have a logic low state for the four bits RD3 to RD0 when using the control register to select the power-down modes or gain setting or when initializing a calibration. The RD bits should also be set to a logic low level to access the ADC results from both D_{OUTA} and D_{OUTB}.

The power-up status of all bits is 0 and the MSB denotes the first bit in the data stream. The bit functions are outlined in Table 8 and Table 9.

Table 8. Control Register Bits

MSB											LSB
Bit 11	Bit 10	Bit 9	Bit 8	Bit 7	Bit 6	Bit 5	Bit 4	Bit 3	Bit 2	Bit 1	Bit 0
RD3	RD2	RD1	RD0	CAL	PD2	PD1	PD0	G3	G2	G1	G0

Table 9. Control Register Bit Function Description

Bits	Mnemonic	Description
11 to 8	RD3 to RD0	Register address bits. These bits select which register the subsequent read is from. See Table 11.
7	CAL	Setting this bit high initiates an internal offset calibration. Once the calibration is completed, this pin can be reset low, and the internal offset, which is stored in the on-chip offset registers, is automatically removed from the ADC results.
6 to 4	PD2 to PD0	Power-down bits. These bits select which power-down mode is programmed. See Table 7.
3 to 0	G3 to G0	Gain selection bits. These bits select which gain setting is used on the front-end PGA. See Table 6.

Table 10. Write Address Bits

WR3	WR2	WR1	WR0	Read Register Addressed
0	0	0	1	Control register

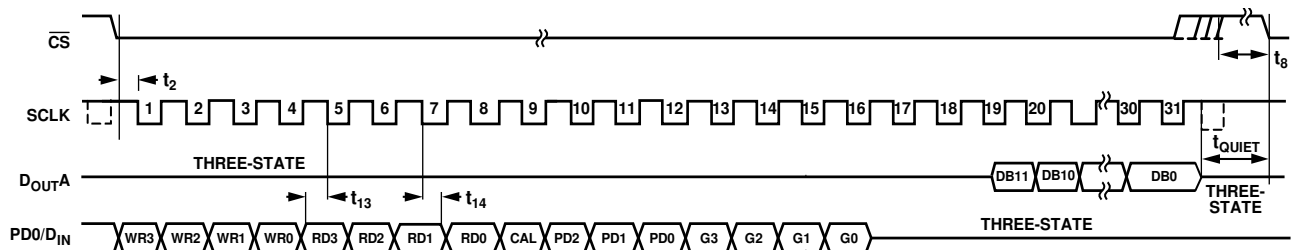

Figure 30. Timing Diagram for a Write Operation to the Control Register

ON-CHIP REGISTERS

The AD7262/AD7262-5 contain a control register, two offset registers for storing the offsets for each ADC, and two external gain registers for storing the gain error. The control register and the offset and gain registers are read and write registers. On power-up, all registers in the AD7262/AD7262-5 are set to 0.

Addressing the On-Chip Registers

Writing to a Register

Data is loaded from the PD0/D_{IN} pin of the AD7262/AD7262-5 on the falling edge of SCLK when CS is in a logic low state. Four address bits and 12 data bits must be clocked into the device. Thus, on the 16th falling SCLK edge, the LSB is clocked into the AD7262/AD7262-5. One more SCLK cycle is then required to write to the internal device registers. In total, 17 SCLK cycles are required to successfully write to the AD7262/AD7262-5. The control and offset registers are 12-bits registers; the gain registers are 7-bit registers.

When writing to a register, the user must first write the address bits corresponding to the selected register. Table 11 shows the decoding of the address bits. The four RD bits are written MSB first, that is, RD3 followed by RD2, RD1, and RD0. The AD7262/AD7262-5 decodes these bits to determine which register is being addressed. The subsequent 12 bits of data are written to the addressed register.

When writing to the external gain registers, the seven bits of data immediately after the four address bits are written to the register. However, 17 SCLK cycles are still required, and the PD0/D_{IN} pin of the AD7262/AD7262-5 should be tied low for the five additional clock cycles.

Table 11. Read and Write Register Addresses

RD3	RD2	RD1	RD0	Comment
0	0	0	0	ADC result (default)
0	0	0	1	Control register
0	0	1	0	Offset ADC A internal
0	0	1	1	Offset ADC B internal
0	1	0	0	Gain ADC A external
0	1	0	1	Gain ADC B external

Reading from a Register

The internal offset of the device, which has been measured by the AD7262/AD7262-5 and stored in the on-chip registers during the calibration, can be read back by the user. The content of the external gain registers can also be read. To read the content of any register, the user must first write to the control register by writing 0001 to the WR3 to WR0 bits via the PD0/D_{IN} pin, as outlined in Table 10. The next four bits in the control register are the RD bits, which are used to select the desired register from which to read. The appropriate 4-bit address for each of the offset and gain registers is outlined in Table 11. The remaining eight SCLK cycles bits are used to set the remaining bits in the control register to the desired state for the next ADC conversion.

The 19th SCLK falling edge clocks out the first data bit of the digital code corresponding to the value stored in the selected internal device register on the D_{OUTA} pin. D_{OUTB} outputs the conversion result from ADC B. Once the selected register has been read, the control register must be reset to output the ADC results for future conversions. This is achieved by writing 0001 to the WR3 to WR0 bits, followed by 0000 to the RD bits. The remaining eight bits in the control register should then be set to the required configuration for the next ADC conversion.

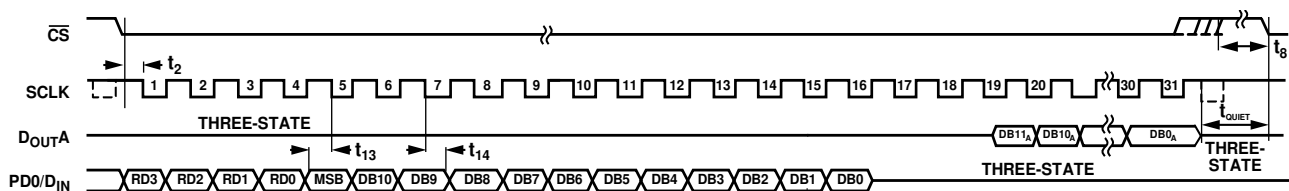

Figure 31. Timing Diagram for Writing to a Register

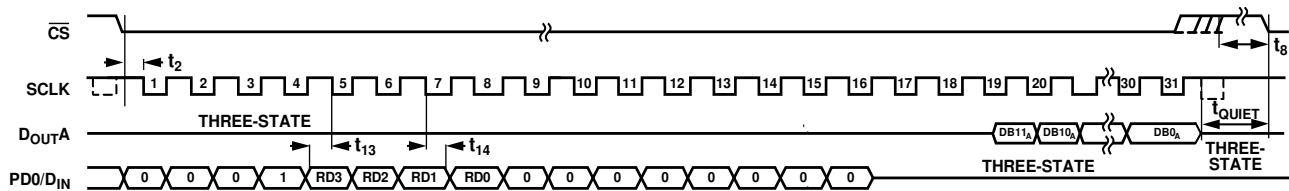

Figure 32. Timing Diagram for a Read Operation with PD0/D_{IN} as an Input