



Chipsmall Limited consists of a professional team with an average of over 10 year of expertise in the distribution of electronic components. Based in Hongkong, we have already established firm and mutual-benefit business relationships with customers from,Europe,America and south Asia,supplying obsolete and hard-to-find components to meet their specific needs.

With the principle of “Quality Parts,Customers Priority,Honest Operation,and Considerate Service”,our business mainly focus on the distribution of electronic components. Line cards we deal with include Microchip,ALPS,ROHM,Xilinx,Pulse,ON,Everlight and Freescale. Main products comprise IC,Modules,Potentiometer,IC Socket,Relay,Connector.Our parts cover such applications as commercial,industrial, and automotives areas.

We are looking forward to setting up business relationship with you and hope to provide you with the best service and solution. Let us make a better world for our industry!



## Contact us

Tel: +86-755-8981 8866 Fax: +86-755-8427 6832

Email & Skype: info@chipsmall.com Web: www.chipsmall.com

Address: A1208, Overseas Decoration Building, #122 Zhenhua RD., Futian, Shenzhen, China



### FEATURES

- 12-Bit Resolution
- Low Gain TC: 2 ppm/°C typ
- Fast TTL Compatible Data Latches
- Single +5 V to +15 V Supply
- Small 20-Lead 0.3" DIP and 20-Terminal Surface Mount Packages
- Latch Free (Schottky Protection Diode Not Required)
- Low Cost
- Ideal for Battery Operated Equipment

### FUNCTIONAL BLOCK DIAGRAM

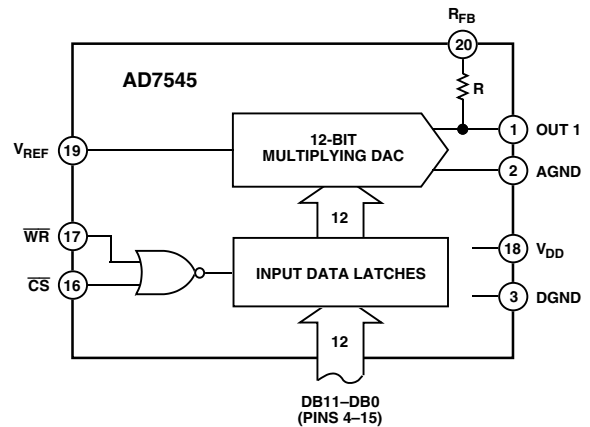

### GENERAL DESCRIPTION

The AD7545 is a monolithic 12-bit CMOS multiplying DAC with onboard data latches. It is loaded by a single 12-bit wide word and directly interfaces to most 12- and 16-bit bus systems. Data is loaded into the input latches under the control of the  $\overline{CS}$  and  $\overline{WR}$  inputs; tying these control inputs low makes the input latches transparent, allowing direct unbuffered operation of the DAC.

The AD7545 is particularly suitable for single supply operation and applications with wide temperature variations.

The AD7545 can be used with any supply voltage from +5 V to +15 V. With CMOS logic levels at the inputs the device dissipates less than 0.5 mW for  $V_{DD} = +5$  V.

### PIN CONFIGURATIONS

#### DIP

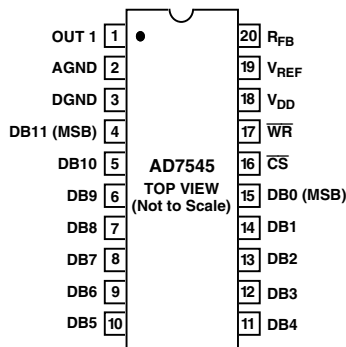

#### LCCC

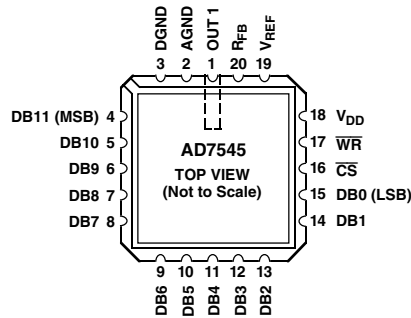

#### PLCC

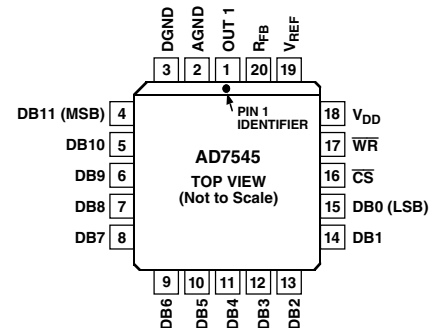

### REV. A

Information furnished by Analog Devices is believed to be accurate and reliable. However, no responsibility is assumed by Analog Devices for its use, nor for any infringements of patents or other rights of third parties which may result from its use. No license is granted by implication or otherwise under any patent or patent rights of Analog Devices.

# AD7545\* PRODUCT PAGE QUICK LINKS

Last Content Update: 02/23/2017

---

## COMPARABLE PARTS

View a parametric search of comparable parts.

## DOCUMENTATION

### Application Notes

- AN-225: 12-Bit Voltage-Output DACs for Single-Supply 5V and 12V Systems

### Data Sheet

- AD7545: CMOS 12-Bit Buffered Multiplying DAC Data Sheet
- AD7545: Military Data Sheet

## REFERENCE MATERIALS

### Solutions Bulletins & Brochures

- Digital to Analog Converters ICs Solutions Bulletin

## DESIGN RESOURCES

- AD7545 Material Declaration
- PCN-PDN Information
- Quality And Reliability
- Symbols and Footprints

## DISCUSSIONS

View all AD7545 EngineerZone Discussions.

## SAMPLE AND BUY

Visit the product page to see pricing options.

## TECHNICAL SUPPORT

Submit a technical question or find your regional support number.

## DOCUMENT FEEDBACK

Submit feedback for this data sheet.

---

# AD7545—SPECIFICATIONS (V<sub>REF</sub> = +10 V, V<sub>OUT1</sub> = 0 V, AGND = DGND unless otherwise noted)

Parameter	Version	V <sub>DD</sub> = +5 V Limits		V <sub>DD</sub> = +15 V Limits		Units	Test Conditions/Comments
		T <sub>A</sub> = +25°C	T <sub>MIN</sub> , T <sub>MAX</sub> <sup>1</sup>	T <sub>A</sub> = +25°C	T <sub>MIN</sub> , T <sub>MAX</sub> <sup>1</sup>		
<b>STATIC PERFORMANCE</b>							
Resolution	All	12	12	12	12	Bits	
	J, A, S	±2	±2	±2	±2	LSB max	
	K, B, T	±1	±1	±1	±1	LSB max	
	L, C, U	±1/2	±1/2	±1/2	±1/2	LSB max	
	GL, GC, GU	±1/2	±1/2	±1/2	±1/2	LSB max	
Differential Nonlinearity	J, A, S	±4	±4	±4	±4	LSB max	10-Bit Monotonic T <sub>MIN</sub> to T <sub>MAX</sub>
	K, B, T	±1	±1	±1	±1	LSB max	12-Bit Monotonic T <sub>MIN</sub> to T <sub>MAX</sub>
	L, C, U	±1	±1	±1	±1	LSB max	12-Bit Monotonic T <sub>MIN</sub> to T <sub>MAX</sub>
	GL, GC, GU	±1	±1	±1	±1	LSB max	12-Bit Monotonic T <sub>MIN</sub> to T <sub>MAX</sub>
Gain Error (Using Internal RFB) <sup>2</sup>	J, A, S	±20	±20	±25	±25	LSB max	DAC Register Loaded with 1111 1111 1111
	K, B, T	±10	±10	±15	±15	LSB max	Gain Error Is Adjustable Using the Circuits of Figures 4, 5, and 6
	L, C, U	±5	±6	±10	±10	LSB max	
	GL, GC, GU	±1	±2	±6	±7	LSB max	
Gain Temperature Coefficient <sup>3</sup> ΔGain/ΔTemperature	All	±5	±5	±10	±10	ppm/°C max	Typical Value is 2 ppm/°C for V <sub>DD</sub> = +5 V
DC Supply Rejection <sup>3</sup> ΔGain/ΔV <sub>DD</sub>	All	0.015	0.03	0.01	0.02	% per % max	ΔV <sub>DD</sub> = ±5%
Output Leakage Current at OUT1	J, K, L, GL	10	50	10	50	nA max	DB0–DB11 = 0 V; $\overline{WR}$ , $\overline{CS}$ = 0 V
	A, B, C, GC	10	50	10	50	nA max	
	S, T, U, GU	10	200	10	200	nA max	
<b>DYNAMIC PERFORMANCE</b>							
Current Settling Time <sup>3</sup>	All	2	2	2	2	μs max	To 1/2 LSB. OUT1 Load = 100 Ω. DAC Output Measured from Falling Edge of $\overline{WR}$ , $\overline{CS}$ = 0.
Propagation Delay <sup>3</sup> (from Digital Input Change to 90% of Final Analog Output)	All	300	–	250	–	ns max	OUT1 Load = 100 Ω, C <sub>EXT</sub> = 13 pF <sup>4</sup>
Digital-to-Analog Glitch Impulse AC Feedthrough <sup>5</sup> At OUT1	All	400	–	250	–	nV sec typ	V <sub>REF</sub> = AGND
	All	5	5	5	5	mV p-p typ	V <sub>REF</sub> = ±10 V, 10 kHz Sinewave
<b>REFERENCE INPUT</b>							
Input Resistance (Pin 19 to GND)	All	7	7	7	7	kΩ min	Input Resistance TC = –300 ppm/°C typ
		25	25	25	25	kΩ max	Typical Input Resistance = 11 kΩ
<b>ANALOG OUTPUT</b>							
Output Capacitance <sup>3</sup> C <sub>OUT1</sub>	All	70	70	70	70	pF max	DB0–DB11 = 0 V, $\overline{WR}$ , $\overline{CS}$ = 0 V
C <sub>OUT1</sub>		200	200	200	200	pF max	DB0–DB11 = V <sub>DD</sub> , $\overline{WR}$ , $\overline{CS}$ = 0 V
<b>DIGITAL INPUTS</b>							
Input High Voltage V <sub>IH</sub>	All	2.4	2.4	13.5	13.5	V min	
Input Low Voltage V <sub>IL</sub>	All	0.8	0.8	1.5	1.5	V max	
Input Current <sup>6</sup> I <sub>IN</sub>	All	±1	±10	±1	±10	μA max	V <sub>IN</sub> = 0 or V <sub>DD</sub>
Input Capacitance <sup>3</sup> DB0–DB11	All	5	5	5	5	pF max	V <sub>IN</sub> = 0
$\overline{WR}$ , $\overline{CS}$	All	20	20	20	20	pF max	V <sub>IN</sub> = 0
<b>SWITCHING CHARACTERISTICS<sup>7</sup></b>							
Chip Select to Write Setup Time t <sub>CS</sub>	All	280	380	180	200	ns min	See Timing Diagram
		200	270	120	150	ns typ	
Chip Select to Write Hold Time t <sub>CH</sub>	All	0	0	0	0	ns min	
Write Pulse Width t <sub>WR</sub>	All	250	400	160	240	ns min	t <sub>CS</sub> ≥ t <sub>WR</sub> , t <sub>CH</sub> ≥ 0
		175	280	100	170	ns typ	
Data Setup Time t <sub>DS</sub>	All	140	210	90	120	ns min	
		100	150	60	80	ns typ	
Data Hold Time t <sub>DH</sub>	All	10	10	10	10	ns min	
<b>POWER SUPPLY</b>							
I <sub>DD</sub>	All	2	2	2	2	mA max	All Digital Inputs V <sub>IL</sub> or V <sub>IH</sub>
		100	500	100	500	μA max	All Digital Inputs 0 V to V <sub>DD</sub>
		10	10	10	10	μA typ	All Digital Inputs 0 V to V <sub>DD</sub>

## NOTES

<sup>1</sup>Temperature range as follows: J, K, L, GL versions, 0°C to +70°C; A, B, C, GC versions, –25°C to +85°C; S, T, U GU versions, –55°C to +125°C.

<sup>2</sup>This includes the effect of 5 ppm max gain TC.

<sup>3</sup>Guaranteed but not tested.

<sup>4</sup>DB0–DB11 = 0 V to V<sub>DD</sub> or V<sub>DD</sub> to 0 V.

<sup>5</sup>Feedthrough can be further reduced by connecting the metal lid on the ceramic package (Suffix D) to DGND.

<sup>6</sup>Logic inputs are MOS gates. Typical input current (+25°C) is less than 1 nA.

<sup>7</sup>Sample tested at +25°C to ensure compliance.

Specifications subject to change without notice.

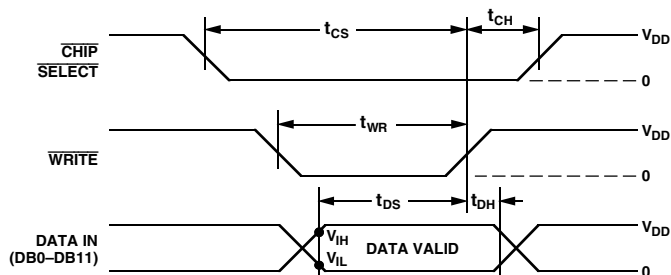

Write Cycle Timing Diagram

MODE SELECTION	
<b>WRITE MODE:</b>	<b>HOLD MODE:</b>
$\overline{CS}$ AND $\overline{WR}$ LOW, DAC RESPONDS TO DATA BUS (DB0-DB11) INPUTS.	EITHER $\overline{CS}$ OR $\overline{WR}$ HIGH, DATA BUS (DB0-DB11) IS LOCKED OUT; DAC HOLDS LAST DATA PRESENT WHEN $\overline{WR}$ OR $\overline{CS}$ ASSUMED HIGH STATE.

NOTES:  
 $V_{DD} = +5V$ ;  $t_r = t_f = 20ns$   
 $V_{DD} = +15V$ ;  $t_r = t_f = 40ns$   
 ALL INPUT SIGNAL RISE AND FALL TIMES MEASURED FROM 10% TO 90% OF  $V_{DD}$ .  
 TIMING MEASUREMENT REFERENCE LEVEL IS  $V_{IH} + V_{IL}/2$ .

### ABSOLUTE MAXIMUM RATINGS\*

( $T_A = +25^\circ C$  unless otherwise noted)

$V_{DD}$ to DGND	−0.3, +17 V
Digital Input Voltage to DGND	−0.3 V, $V_{DD} + 0.3$ V
$V_{RFB}$ , $V_{REF}$ to DGND	±25 V
$V_{PIN1}$ to DGND	−0.3 V, $V_{DD} + 0.3$ V
AGND to DGND	−0.3 V, $V_{DD} + 0.3$ V
Power Dissipation (Any Package) to $+75^\circ C$	450 mW
Derates above $+75^\circ C$	6 mW/ $^\circ C$
Operating Temperature	

Commercial (J, K, L, GL) Grades	0°C to +70°C
Industrial (A, B, C, GC) Grades	−25°C to +85°C
Extended (S, T, U, GU) Grades	−55°C to +125°C
Storage Temperature	−65°C to +150°C
Lead Temperature (Soldering, 10 secs)	+300°C

\*Stresses above those listed under Absolute Maximum Ratings may cause permanent damage to the device. This is a stress rating only; functional operation of the device at these or any other conditions above those indicated in the operational sections of this specification is not implied. Exposure to absolute maximum rating conditions for extended periods may affect device reliability.

### CAUTION

ESD (electrostatic discharge) sensitive device. Electrostatic charges as high as 4000 V readily accumulate on the human body and test equipment and can discharge without detection. Although the AD7545 features proprietary ESD protection circuitry, permanent damage may occur on devices subjected to high energy electrostatic discharges. Therefore, proper ESD precautions are recommended to avoid performance degradation or loss of functionality.



### TERMINOLOGY

#### RELATIVE ACCURACY

The amount by which the D/A converter transfer function differs from the ideal transfer function after the zero and full-scale points have been adjusted. This is an endpoint linearity measurement.

#### DIFFERENTIAL NONLINEARITY

The difference between the measured change and the ideal change between any two adjacent codes. If a device has a differential nonlinearity of less than 1 LSB it will be monotonic, i.e., the output will always increase for an increase in digital code applied to the D/A converter.

#### PROPAGATION DELAY

This is a measure of the internal delay of the circuit and is measured from the time a digital input changes to the point at which the analog output at OUT1 reaches 90% of its final value.

#### DIGITAL-TO-ANALOG GLITCH IMPULSE

This is a measure of the amount of charge injected from the digital inputs to the analog outputs when the inputs change state. It is usually specified as the area of the glitch in nV secs and is measured with  $V_{REF} = AGND$  and an ADLH0032CG as the output op amp, C1 (phase compensation) = 33 pF.

### ORDERING GUIDE<sup>1</sup>

Model <sup>2</sup>	Temperature Range	Relative Accuracy	Maximum Gain Error $T_A = +25^\circ C$ $V_{DD} = +5 V$	Package Options <sup>3</sup>
AD7545JN	0°C to +70°C	±2 LSB	±20 LSB	N-20
AD7545AQ	−25°C to +85°C	±2 LSB	±20 LSB	Q-20
AD7545SQ	−55°C to +125°C	±2 LSB	±20 LSB	Q-20
AD7545KN	0°C to +70°C	±1 LSB	±10 LSB	N-20
AD7545BQ	−25°C to +85°C	±1 LSB	±10 LSB	Q-20
AD7545TQ	−55°C to +125°C	±1 LSB	±10 LSB	Q-20
AD7545LN	0°C to +70°C	±1/2 LSB	±5 LSB	N-20
AD7545CQ	−25°C to +85°C	±1/2 LSB	±5 LSB	Q-20
AD7545UQ	−55°C to +125°C	±1/2 LSB	±5 LSB	Q-20
AD7545GLN	0°C to +70°C	±1/2 LSB	±1 LSB	N-20
AD7545GCQ	−25°C to +85°C	±1/2 LSB	±1 LSB	Q-20
AD7545GUQ	−55°C to +125°C	±1/2 LSB	±1 LSB	Q-20
AD7545JP	0°C to +70°C	±2 LSB	±20 LSB	P-20A
AD7545SE	−55°C to +125°C	±2 LSB	±20 LSB	E-20A
AD7545KP	0°C to +70°C	±1 LSB	±10 LSB	P-20A
AD7545TE	−55°C to +125°C	±1 LSB	±10 LSB	E-20A
AD7545LP	0°C to +70°C	±1/2 LSB	±5 LSB	P-20A
AD7545UE	−55°C to +125°C	±1/2 LSB	±5 LSB	E-20A
AD7545GLP	0°C to +70°C	±1/2 LSB	±1 LSB	P-20A
AD7545GUE	−55°C to +125°C	±1/2 LSB	±1 LSB	E-20A

#### NOTES

<sup>1</sup>Analog Devices reserves the right to ship either ceramic (D-20) in lieu of cerdip packages (Q-20).

<sup>2</sup>To order MIL-STD-883, Class B process parts, add /883B to part number. Contact local sales office for military data sheet. For U.S. Standard Military DRAWING (SMD) see DESC drawing 5962-87702.

<sup>3</sup>E = Leadless Ceramic Chip Carrier; N = Plastic DIP; P = Plastic Leaded Chip Carrier; Q = Cerdip.

# AD7545

## CIRCUIT INFORMATION—D/A CONVERTER SECTION

Figure 1 shows a simplified circuit of the D/A converter section of the AD7545 and Figure 2 gives an approximate equivalent circuit. Note that the ladder termination resistor is connected to AGND. R is typically 11 kΩ.

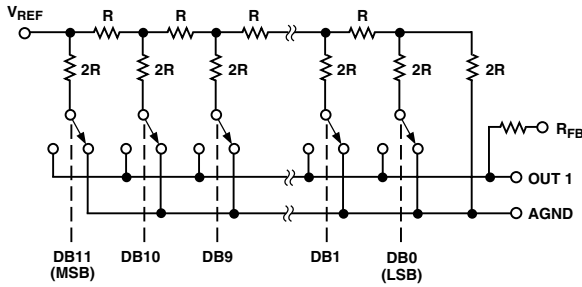

Figure 1. Simplified D/A Circuit of AD7545

The binary weighted currents are switched between the OUT1 bus line and AGND by N-channel switches, thus maintaining a constant current in each ladder leg independent of the switch state.

The capacitance at the OUT1 bus line,  $C_{OUT1}$ , is code dependent and varies from 70 pF (all switches to AGND) to 200 pF (all switches to OUT1).

One of the current switches is shown in Figure 2. The input resistance at  $V_{REF}$  (Figure 1) is always equal to  $R_{LDR}$  ( $R_{LDR}$  is the  $R/2R$  ladder characteristic resistance and is equal to value “R”). Since  $R_{IN}$  at the  $V_{REF}$  pin is constant, the reference terminal can be driven by a reference voltage or a reference current, ac or dc, of positive or negative polarity. (If a current source is used, a low temperature coefficient external  $R_{FB}$  is recommended to define scale factor.)

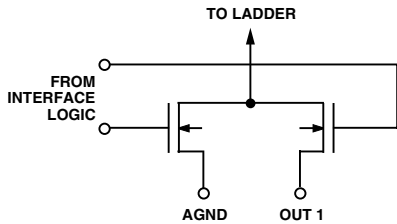

Figure 2. N-Channel Current Steering Switch

## CIRCUIT INFORMATION—DIGITAL SECTION

Figure 3 shows the digital structure for one bit.

The digital signals CONTROL and  $\overline{\text{CONTROL}}$  are generated from  $\overline{\text{CS}}$  and  $\overline{\text{WR}}$ .

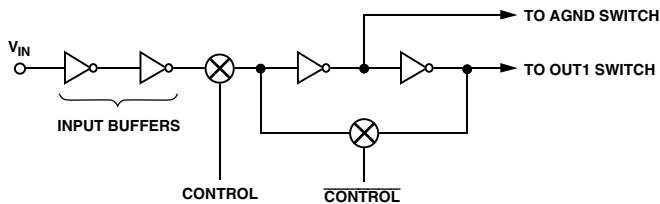

Figure 3. Digital Input Structure

The input buffers are simple CMOS inverters designed so that when the AD7545 is operated with  $V_{DD} = 5$  V, the buffers convert TTL input levels (2.4 V and 0.8 V) into CMOS logic levels. When  $V_{IN}$  is in the region of 2.0 volts to 3.5 volts, the input buffers operate in their linear region and draw current from the

power supply. To minimize power supply currents it is recommended that the digital input voltages be as close as practically possible to the supply rails ( $V_{DD}$  and DGND).

The AD7545 may be operated with any supply voltage in the range  $5 \leq V_{DD} \leq 15$  volts. With  $V_{DD} = +15$  V the input logic levels are CMOS compatible only, i.e., 1.5 V and 13.5 V.

## BASIC APPLICATIONS

Figures 4 and 5 show simple unipolar and bipolar circuits using the AD7545. Resistor R1 is used to trim for full scale. The “G” versions (AD7545GLN, AD7545GCQ, AD7545GUD) have a guaranteed maximum gain error of  $\pm 1$  LSB at  $+25^\circ\text{C}$  ( $V_{DD} = +5$  V), and in many applications it should be possible to dispense with gain trim resistors altogether. Capacitor C1 provides phase compensation and helps prevent overshoot and ringing when using high speed op amps. Note that all the circuits of Figures 4, 5 and 6 have constant input impedance at the  $V_{REF}$  terminal.

The circuit of Figure 1 can either be used as a fixed reference D/A converter so that it provides an analog output voltage in the range 0 to  $-V_{IN}$  (note the inversion introduced by the op amp), or  $V_{IN}$  can be an ac signal in which case the circuit behaves as an attenuator (2-Quadrant Multiplier).  $V_{IN}$  can be any voltage in the range  $-20 \leq V_{IN} \leq +20$  volts (provided the op amp can handle such voltages) since  $V_{REF}$  is permitted to exceed  $V_{DD}$ . Table II shows the code relationship for the circuit of Figure 4.

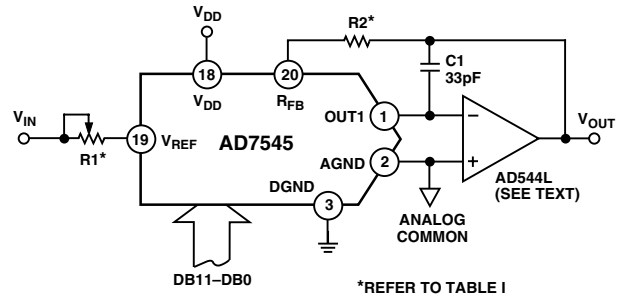

Figure 4. Unipolar Binary Operation

Table I. Recommended Trim Resistor Values vs. Grades for  $V_{DD} = +5$  V

Trim Resistor	J/A/S	K/B/T	L/C/U	GL/GC/GU
R1	500 Ω	200 Ω	100 Ω	20 Ω
R2	150 Ω	68 Ω	33 Ω	6.8 Ω

Table II. Unipolar Binary Code Table for Circuit of Figure 4

Binary Number in DAC Register	Analog Output
1 1 1 1    1 1 1 1    1 1 1 1	$-V_{IN} \left( \frac{4095}{4096} \right)$
1 0 0 0    0 0 0 0    0 0 0 0	$-V_{IN} \left( \frac{2048}{4096} \right) = -1/2 V_{IN}$
0 0 0 0    0 0 0 0    0 0 0 1	$-V_{IN} \left( \frac{1}{4096} \right)$
0 0 0 0    0 0 0 0    0 0 0 0	0 Volts

Figure 5 and Table III illustrate the recommended circuit and code relationship for bipolar operation. The D/A function itself uses offset binary code and inverter U<sub>1</sub> on the MSB line converts twos complement input code to offset binary code. If appropriate; inversion of the MSB may be done in software using an exclusive-OR instruction and the inverter omitted. R<sub>3</sub>, R<sub>4</sub> and R<sub>5</sub> must be selected to match within 0.01% and they should be the same type of resistor (preferably wire-wound or metal foil), so their temperature coefficients match. Mismatch of R<sub>3</sub> value to R<sub>4</sub> causes both offset and full-scale error. Mismatch of R<sub>5</sub> and R<sub>4</sub> and R<sub>3</sub> causes full-scale error.

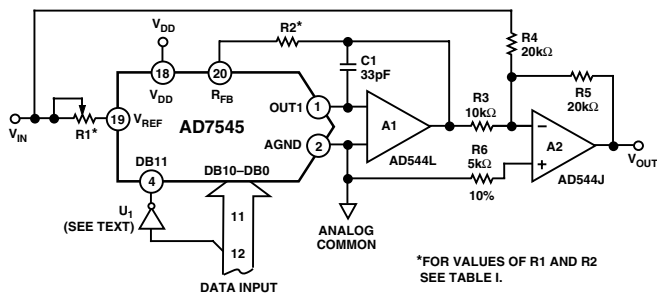

Figure 5. Bipolar Operation (Twos Complement Code)

Table III. Twos Complement Code Table for Circuit of Figure 5

Data Input	Analog Output
0 1 1 1    1 1 1 1    1 1 1 1	$+V_{IN} \times \left( \frac{2047}{2048} \right)$
0 0 0 0    0 0 0 0    0 0 0 1	$+V_{IN} \times \left( \frac{1}{2048} \right)$
0 0 0 0    0 0 0 0    0 0 0 0	0 Volts
1 1 1 1    1 1 1 1    1 1 1 1	$-V_{IN} \times \left( \frac{1}{2048} \right)$
1 0 0 0    0 0 0 0    0 0 0 0	$-V_{IN} \times \left( \frac{2048}{2048} \right)$

Figure 6 shows an alternative method of achieving bipolar output. The circuit operates with sign plus magnitude code and has the advantage of giving 12-bit resolution in each quadrant, compared with 11-bit resolution per quadrant for the circuit of Figure 5. The AD7592 is a fully protected CMOS change-over switch with data latches. R<sub>4</sub> and R<sub>5</sub> should match each other to 0.01% to maintain the accuracy of the D/A converter. Mismatch between R<sub>4</sub> and R<sub>5</sub> introduces a gain error.

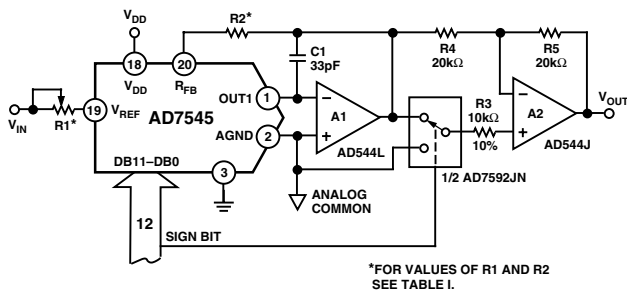

Figure 6. 12-Bit Plus Sign Magnitude D/A Converter

Table IV. 12-Plus Sign Magnitude Code Table for Circuit of Figure 6

Sign Bit	Binary Number in DAC MSB                      LSB	Analog Output, V <sub>OUT</sub>
0	1 1 1 1    1 1 1 1    1 1 1 1	$+V_{IN} \times \left( \frac{4095}{4096} \right)$
0	0 0 0 0    0 0 0 0    0 0 0 0	0 Volts
1	0 0 0 0    0 0 0 0    0 0 0 0	0 Volts
1	1 1 1 1    1 1 1 1    1 1 1 1	$-V_{IN} \times \left( \frac{4095}{4096} \right)$

Note: Sign bit of "0" connects R<sub>3</sub> to GND.

APPLICATIONS HINTS

**Output Offset:** (CMOS D/A converters exhibit a code dependent output resistance which, in turn, causes a code dependent amplifier noise gain. The effect is a code dependent differential nonlinearity term at the amplifier output that depends on V<sub>OS</sub> where V<sub>OS</sub> is the amplifier input offset voltage. To maintain monotonic operation it is recommended that V<sub>OS</sub> be no greater than  $25 \times 10^{-6}$  (V<sub>REF</sub>) over the temperature range of operation. Suitable op amps are AD517L and AD544L. The AD517L is best suited for fixed reference applications with low bandwidth requirements: it has extremely low offset (50 μV) and in most applications will not require an offset trim. The AD544L has a much wider bandwidth and higher slew rate and is recommended for multiplying and other applications requiring fast settling. An offset trim on the AD544L may be necessary in some circuits.

**General Ground Management:** AC or transient voltages between AGND and DGND can cause noise injection into the analog output. The simplest method of ensuring that voltages at AGND and DGND are equal is to tie AGND and DGND together at the AD7545. In more complex systems where the AGND and DGND intertie is on the backplane, it is recommended that two diodes be connected in inverse parallel between the AD7545 AGND and DGND pins (IN914 or equivalent).

**Digital Glitches:** When WR and CS are both low the latches are transparent and the D/A converter inputs follow the data inputs. In some bus systems, data on the data bus is not always valid for the whole period during which WR is low and as a result invalid data can briefly occur at the D/A converter inputs during a write cycle. Such invalid data can cause unwanted glitches at the output of the D/A converter. The solution to this problem, if it occurs, is to retime the write pulse WR so that it only occurs when data is valid.

Another cause of digital glitches is capacitive coupling from the digital lines to the OUT1 and AGND terminals. This should be minimized by screening the analog pins of the AD7545 (Pins 1, 2, 19, 20) from the digital pins by a ground track run between Pins 2 and 3 and between Pins 18 and 19 of the AD7545. Note how the analog pins are at one end of the package and separated from the digital pins by V<sub>DD</sub> and DGND to aid screening at the board level. On-chip capacitive coupling can also give rise to crosstalk from the digital-to-analog sections of the AD7545, particularly in circuits with high currents and fast rise and fall times. This type of crosstalk is minimized by using

# AD7545

$V_{DD} = +5$  volts. However, great care should be taken to ensure that the +5 V used to power the AD7545 is free from digitally induced noise.

**Temperature Coefficients:** The gain temperature coefficient of the AD7545 has a maximum value of 5 ppm/°C and a typical value of 2 ppm/°C. This corresponds to worst case gain shifts of 2 LSBs and 0.8 LSBs respectively over a 100°C temperature range. When trim resistors R1 and R2 are used to adjust full-scale range, the temperature coefficient of R1 and R2 should also be taken into account. The reader is referred to Analog Devices Application Note “Gain Error and Gain Temperature Coefficient of CMOS Multiplying DACs,” Publication Number E630-10-6/81.

## SINGLE SUPPLY OPERATION

The ladder termination resistor of the AD7545 (Figure 1) is connected to AGND. This arrangement is particularly suitable for single supply operation because OUT1 and AGND may be biased at any voltage between DGND and  $V_{DD}$ . OUT1 and AGND should never go more than 0.3 volts less than DGND or an internal diode will be turned on and a heavy current may flow which will damage the device. (The AD7545 is, however, protected from the SCR latch-up phenomenon prevalent in many CMOS devices.)

Figure 7 shows the AD7545 connected in a voltage switching mode. OUT1 is connected to the reference voltage and AGND is connected to DGND. The D/A converter output voltage is available at the  $V_{REF}$  pin and has a constant output impedance equal to R.  $R_{FB}$  is not used in this circuit.

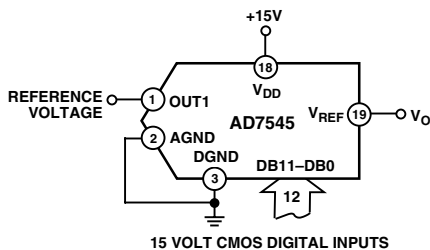

Figure 7. Single Supply Operation Using Voltage Switching Mode

The loading on the reference voltage source is code dependent and the response time of the circuit is often determined by the behavior of the reference voltage with changing load conditions.

To maintain linearity, the voltages at OUT1 and AGND should remain within 2.5 volts of each other, for a  $V_{DD}$  of 15 volts. If  $V_{DD}$  is reduced from 15 V, or the differential voltage between OUT1 and AGND is increased to more than 2.5 V, the differential nonlinearity of the DAC will increase and the linearity of the DAC will be degraded. Figures 8 and 9 show typical curves illustrating this effect for various values of reference voltage and  $V_{DD}$ . If the output voltage is required to be offset from ground by some value, then OUT1 and AGND may be biased up. The effect on linearity and differential nonlinearity will be the same as reducing  $V_{DD}$  by the amount of the offset.

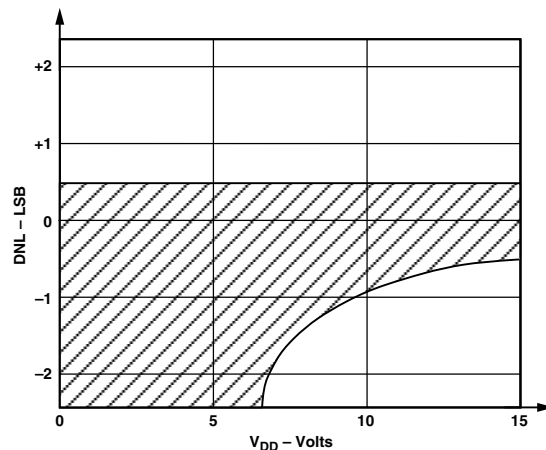

Figure 8. Differential Nonlinearity vs.  $V_{DD}$  for Figure 7 Circuit. Reference Voltage = 2.5 Volts. Shaded Area Shows Range of Values of Differential Nonlinearity that Typically Occur for L, C and U Grades.

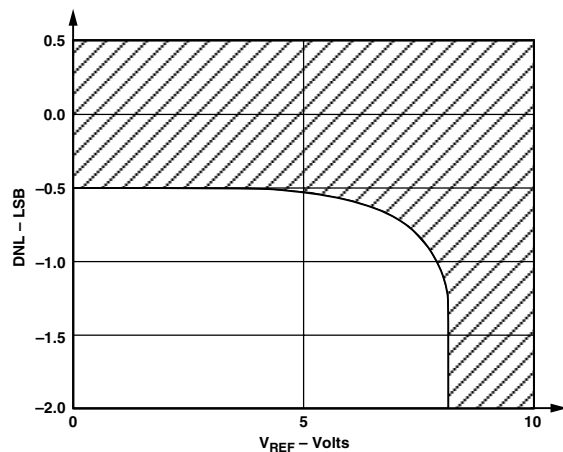

Figure 9. Differential Nonlinearity vs. Reference Voltage for Figure 7 Circuit.  $V_{DD} = 15$  Volts. Shaded Area Shows Range of Values of Differential Nonlinearity that Typically Occur for L, C and U Grades.

The circuits of Figures 4, 5 and 6 can all be converted to single supply operation by biasing AGND to some voltage between  $V_{DD}$  and DGND. Figure 10 shows the two complement bipolar circuit of Figure 5 modified to give a range from +2 V to +8 V about a “pseudo-analog ground” of 5 V. This voltage range would allow operation from a single  $V_{DD}$  of +10 V to +15 V. The AD584 pin-programmable reference fixes AGND at +5 V.  $V_{IN}$  is set at +2 V by means of the series resistors R1 and R2. There is no need to buffer the  $V_{REF}$  input to the AD7545 with an amplifier because the input impedance of the D/A converter is constant. Note, however, that since the temperature coefficient of the D/A reference input resistance is typically -300 ppm/°C; applications that experience wide temperature variations may require a buffer amplifier to generate the +2.0 V at the AD7545  $V_{REF}$  pin. Other output voltage ranges can be obtained by changing R4 to shift the zero point and (R1 + R2) to change the slope, or gain, of the D/A transfer function.  $V_{DD}$  must be kept at least 5 V above OUT1 to ensure that linearity is preserved.



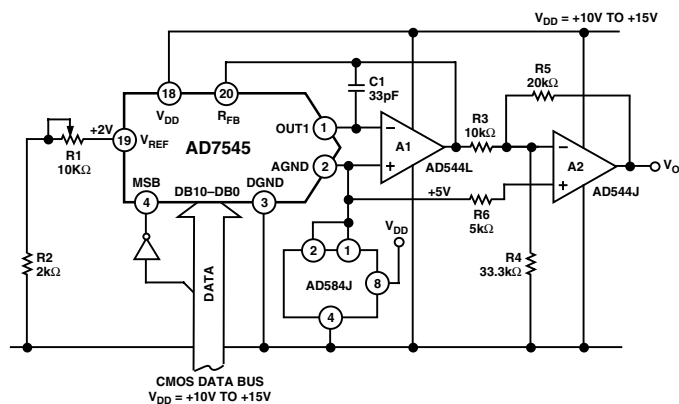

Figure 10. Single Supply "Bipolar" Twos Complement D/A Converter

### MICROPROCESSOR INTERFACING OF THE AD7545

The AD7545 can directly interface to both 8- and 16-bit microprocessors via its 12-bit wide data latch using standard CS and WR control signals.

A typical interface circuit for an 8-bit processor is shown in Figure 11. This arrangement uses two memory addresses, one for the lower eight bits of data to the DAC and one for the upper four bits of data into the DAC via the latch.

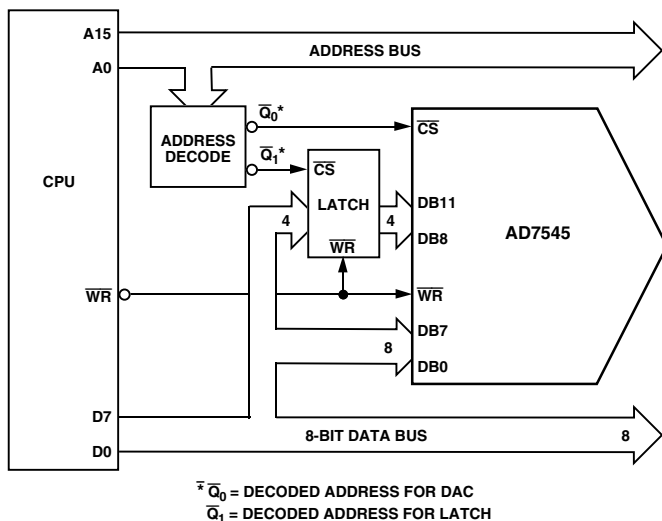

Figure 11. 8-Bit Processor to AD7545 Interface

Figure 12 shows an alternative approach for use with 8-bit processors which have a full 16-bit wide address bus such as 6800, 8080, Z80. This technique uses the 12 lower address lines of the processor address bus to supply data to the DAC, thus each AD7545 connected in this way uses 4k bytes of address locations. Data is written to the DAC using a single memory write instruction. The address field of the instruction is organized so that the lower 12 bits contain the data for the DAC and the upper 4 bits contain the address of the 4k block at which the DAC resides.

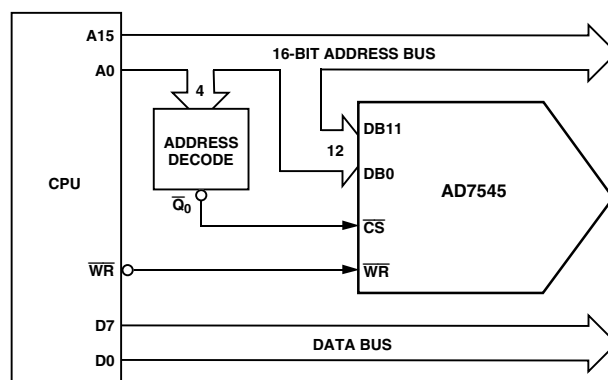

Figure 12. Connecting the AD7545 to 8-Bit Processors via the Address Bus

### SUPPLEMENTAL APPLICATION MATERIAL

For further information on CMOS multiplying D/A converters the reader is referred to the following texts:

Application Guide to CMOS Multiplying D/A converters available from Analog Devices, Publication Number G479.

Gain Error and Gain Temperature Coefficient of CMOS Multiplying DACs—Application Note, Publication Number E630-10-6/81 available from Analog Devices.

## OUTLINE DIMENSIONS

Dimensions shown in inches and (mm).

### 20-Lead Plastic DIP (N-20)

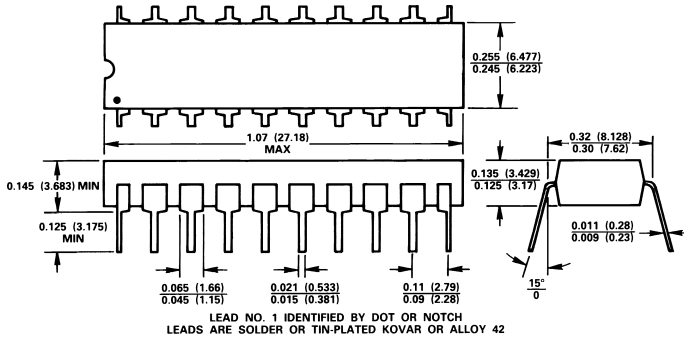

### 20-Lead Cerdip (Q-20)

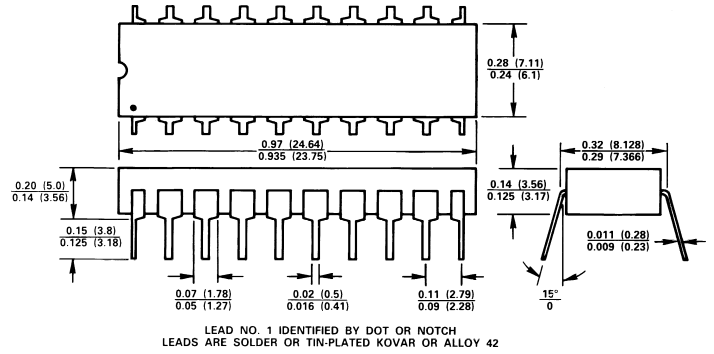

### 20-Terminal Leadless Ceramic Chip Carrier (LCCC) (E-20A)

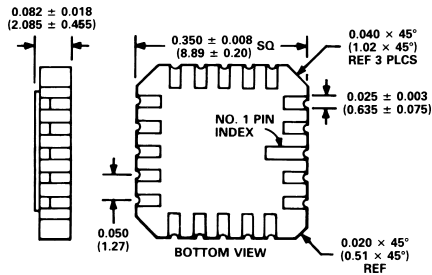

### 20-Lead Plastic Leaded Chip Carrier (PLCC) (P-20A)

