



Chipsmall Limited consists of a professional team with an average of over 10 year of expertise in the distribution of electronic components. Based in Hongkong, we have already established firm and mutual-benefit business relationships with customers from,Europe,America and south Asia,supplying obsolete and hard-to-find components to meet their specific needs.

With the principle of “Quality Parts,Customers Priority,Honest Operation,and Considerate Service”,our business mainly focus on the distribution of electronic components. Line cards we deal with include Microchip,ALPS,ROHM,Xilinx,Pulse,ON,Everlight and Freescale. Main products comprise IC,Modules,Potentiometer,IC Socket,Relay,Connector.Our parts cover such applications as commercial,industrial, and automotives areas.

We are looking forward to setting up business relationship with you and hope to provide you with the best service and solution. Let us make a better world for our industry!



Contact us

Tel: +86-755-8981 8866 Fax: +86-755-8427 6832

Email & Skype: info@chipsmall.com Web: www.chipsmall.com

Address: A1208, Overseas Decoration Building, #122 Zhenhua RD., Futian, Shenzhen, China





FEATURES

- 120 dB dynamic range at 78 kHz output data rate
- 109 dB dynamic range at 625 kHz output data rate
- 112 dB SNR at 78 kHz output data rate
- 106 dB SNR at 625 kHz output data rate
- 625 kHz maximum fully filtered output word rate
- Programmable over-sampling rate (32× to 256×)
- Fully differential modulator input
- On-chip differential amplifier for signal buffering
- Low-pass finite impulse response (FIR) filter with default or user-programmable coefficients
- Overrange alert bit
- Digital offset and gain correction registers
- Filter bypass modes
- Low power and power-down modes
- Synchronization of multiple devices via SYNC pin

APPLICATIONS

- Data acquisition systems
- Vibration analysis
- Instrumentation

GENERAL DESCRIPTION

The AD7762 is a high performance, 24-bit Σ - Δ analog-to-digital converter (ADC). It combines wide input bandwidth and high speed with the benefits of Σ - Δ conversion with a performance of 106 dB SNR at 625 kSPS, making it ideal for high speed data acquisition. Wide dynamic range combined with significantly reduced antialiasing requirements simplify the design process. An integrated buffer to drive the reference, a differential amplifier for signal buffering and level shifting, an overrange flag, internal gain and offset registers, and a low-pass digital FIR filter make the AD7762 a compact, highly integrated data acquisition device requiring minimal peripheral component selection. In addition, the device offers programmable decimation rates, and the digital FIR filter can be adjusted if the default characteristics are not appropriate to the application. The AD7762 is ideal for applications demanding high SNR without a complex front end signal processing design.

The differential input is sampled at up to 40 MSPS by an analog modulator. The modulator output is processed by a series of low-pass filters, the final filter having default or user-programmable

FUNCTIONAL BLOCK DIAGRAM

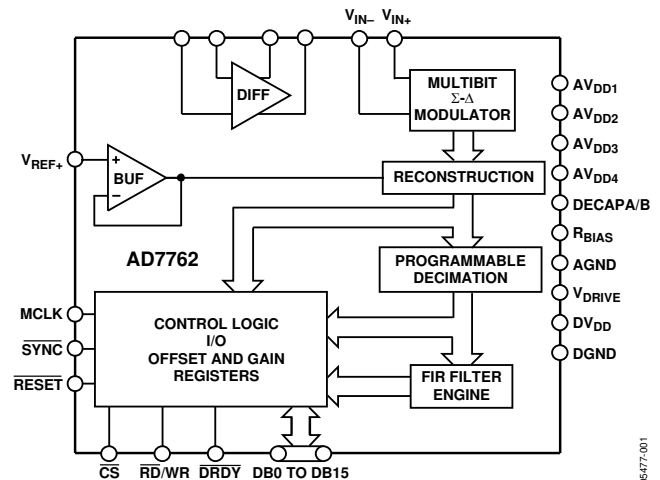

Figure 1.

coefficients. The sample rate, filter corner frequencies, and output word rate are set by a combination of the external clock frequency and the configuration registers of the AD7762.

The reference voltage supplied to the AD7762 determines the analog input range. With a 4 V reference, the analog input range is ± 3.2 V differential biased around a common mode of 2 V. This common-mode biasing can be achieved using the on-chip differential amplifier, further reducing the external signal conditioning requirements.

The AD7762 is available in an exposed paddle, 64-lead TQFP and is specified over the industrial temperature range from -40°C to $+85^{\circ}\text{C}$.

Table 1. Related Devices

| Part No. | Description |
|----------|---|
| AD7760 | 24-bit, 2.5 MSPS, 100 dB Σ - Δ , parallel interface |
| AD7763 | 24-bit, 625 kSPS, 109 dB Σ - Δ , serial interface |

AD7762* PRODUCT PAGE QUICK LINKS

Last Content Update: 02/23/2017

COMPARABLE PARTS

View a parametric search of comparable parts.

EVALUATION KITS

- AD7760 / AD7762 Evaluation Board

DOCUMENTATION

Application Notes

- AN-280: Mixed Signal Circuit Technologies
- AN-282: Fundamentals of Sampled Data Systems
- AN-283: Sigma-Delta ADCs and DACs
- AN-311: How to Reliably Protect CMOS Circuits Against Power Supply Overvoltage
- AN-342: Analog Signal-Handling for High Speed and Accuracy
- AN-388: Using Sigma-Delta Converters-Part 1
- AN-389: Using Sigma-Delta Converters-Part 2

Data Sheet

- AD7762: 625 kSPS, 24-Bit, 109 dB Sigma-Delta ADC With On-Chip Buffer Data Sheet

User Guides

- UG-593: Evaluating the AD7760 and AD7762 Using the EVAL-CED1Z

TOOLS AND SIMULATIONS

- Sigma-Delta ADC Tutorial

REFERENCE MATERIALS

Technical Articles

- MS-2210: Designing Power Supplies for High Speed ADC
- Vibration Analysis Using ADCs Keeps Industrial Equipment Working

DESIGN RESOURCES

- AD7762 Material Declaration
- PCN-PDN Information
- Quality And Reliability
- Symbols and Footprints

DISCUSSIONS

View all AD7762 EngineerZone Discussions.

SAMPLE AND BUY

Visit the product page to see pricing options.

TECHNICAL SUPPORT

Submit a technical question or find your regional support number.

DOCUMENT FEEDBACK

Submit feedback for this data sheet.

TABLE OF CONTENTS

| | | | |
|--|----|--|----|
| Features | 1 | Driving the AD7762..... | 16 |
| Applications..... | 1 | Using the AD7762 | 17 |
| Functional Block Diagram | 1 | Bias Resistor Selection | 17 |
| General Description | 1 | Decoupling and Layout Recommendations..... | 18 |
| Revision History | 2 | Supply Decoupling | 19 |
| Specifications..... | 3 | Additional Decoupling | 19 |
| Timing Specifications..... | 5 | Reference Voltage Filtering | 19 |
| Timing Diagrams..... | 5 | Differential Amplifier Components | 19 |
| Absolute Maximum Ratings..... | 6 | Layout Considerations..... | 19 |
| ESD Caution..... | 6 | Programmable FIR Filter | 20 |
| Pin Configuration and Function Descriptions..... | 7 | Downloading a User-Defined Filter | 21 |
| Terminology | 9 | Example Filter Download | 21 |
| Typical Performance Characteristics | 10 | AD7762 Registers | 23 |
| Theory of Operation | 13 | Control Register 1—Reg 0x0001 | 23 |
| AD7762 Interface..... | 14 | Control Register 2—Address 0x0002 | 23 |
| Reading Data..... | 14 | Status Register (Read Only) | 24 |
| Sharing the Parallel Bus..... | 14 | Offset Register—Address 0x0003..... | 24 |
| Writing to the AD7762 | 14 | Gain Register—Address 0x0004..... | 24 |
| Reading Status and Other Registers..... | 14 | Ovrrange Register—Address 0x0005..... | 24 |
| Clocking the AD7762 | 15 | Outline Dimensions | 25 |
| Example 1 | 15 | Ordering Guide | 25 |
| Example 2 | 15 | | |

REVISION HISTORY

1/14—Rev. 0 to Rev. A

| | |
|---|----|
| Added Exposed Pad Notation, Figure 4 and Table 5..... | 7 |
| Change to Figure 31..... | 20 |
| Updated Outline Dimensions..... | 25 |

8/05—Revision 0: Initial Version

SPECIFICATIONS

$AV_{DD1} = DV_{DD} = V_{DRIVE} = 2.5\text{ V}$, $AV_{DD2} = AV_{DD3} = AV_{DD4} = 5\text{ V}$, $V_{REF} = 4.096\text{ V}$, MCLK amplitude = 5 V, $T_A = 25^\circ\text{C}$, normal mode, using on-chip amplifier with components as shown in Table 8, unless otherwise noted.¹

Table 2.

| Parameter | Test Conditions/Comments | Specification | Unit |
|--|--|---------------|----------------|
| DYNAMIC PERFORMANCE | | | |
| Decimate by 256 Dynamic Range | MCLK = 40 MHz, ODR = 78 kHz, FIN = 1 kHz Modulator inputs shorted | 119 | dB min |
| | | 120.5 | dB typ |
| Signal-to-Noise Ratio (SNR) ² | Input amplitude = -0.5 dBFS Input amplitude = -60 dBFS | 112 | dB typ |
| | | 59 | dB typ |
| Spurious-Free Dynamic Range (SFDR) | Nonharmonic, input amplitude = -6 dBFS Input amplitude = -60 dBFS | 126 | dBc typ |
| | | 77 | dBc typ |
| Total Harmonic Distortion (THD) | Input amplitude = -0.5 dBFS Input amplitude = -6 dBFS Input amplitude = -60 dBFS | -105 | dB typ |
| | | -106 | dB typ |
| | | -75 | dB typ |
| Decimate by 64 Dynamic Range | MCLK = 40 MHz, ODR = 312.5 kHz, FIN = 1 kHz Modulator inputs shorted | 112 | dB min |
| | | 114 | dB typ |
| Signal-to-Noise Ratio (SNR) ² | Input amplitude = -0.5 dBFS | 109.5 | dB typ |
| Spurious-Free Dynamic Range (SFDR) | Nonharmonic, input amplitude = -6 dBFS | 126 | dBc typ |
| Decimate by 32 Dynamic Range | MCLK = 40 MHz, ODR = 625 kHz, FIN = 100 kHz Modulator inputs shorted | 108 | dB min |
| | | 109.5 | dB typ |
| Signal-to-Noise Ratio (SNR) ² | Input amplitude = -0.5 dBFS | 107 | dB typ |
| Spurious-Free Dynamic Range (SFDR) | Nonharmonic, input amplitude = -6 dBFS | 120 | dBc typ |
| Total Harmonic Distortion (THD) | Input amplitude = -0.5 dBFS Input amplitude = -6 dBFS | -108 | dB typ |
| | | -106 | dB typ |
| DC ACCURACY | | | |
| Resolution | Guaranteed monotonic to 24 bits | 24 | Bits |
| Differential Nonlinearity | | 0.00076 | % typ |
| Integral Nonlinearity | | | % typ |
| Zero Error | | | % max |
| Gain Error | | 0.015 | % typ |
| Zero Error Drift | | 0.019 | %/°C typ |
| Gain Error Drift | | 0.0002 | %/°C typ |
| DIGITAL FILTER RESPONSE | | | |
| Decimate by 32 Group Delay | MCLK = 40 MHz | 47 | μs typ |
| | | 91.5 | μs typ |
| Decimate by 64 Group Delay | MCLK = 40 MHz | | |
| Decimate by 256 Group Delay | MCLK = 40 MHz | 358 | μs typ |
| ANALOG INPUT | | | |
| Differential Input Voltage | $V_{IN(+)} - V_{IN(-)}$, $V_{REF} = 2.5\text{ V}$ $V_{IN(+)} - V_{IN(-)}$, $V_{REF} = 4.096\text{ V}$ | ±2 ±3.25 | V p-p V p-p |
| Input Capacitance | At internal buffer inputs | 5 | pF typ |
| | At modulator inputs | 55 | pF typ |

| Parameter | Test Conditions/Comments | Specification | Unit |
|--------------------------------------|--|------------------------|-------------------|
| REFERENCE INPUT/OUTPUT | | | |
| V_{REF} Input Voltage | $V_{DD3} = 3.3\text{ V} \pm 5\%$ $V_{DD3} = 5\text{ V} \pm 5\%$ | +2.5 +4.096 | V max V max |
| V_{REF} Input DC Leakage Current | | ± 6 | μA max |
| V_{REF} Input Capacitance | | 5 | pF max |
| POWER DISSIPATION | | | |
| Total Power Dissipation | Normal mode Low power mode | 958 661 | mW max mW max |
| Standby Mode | Clock stopped | 6.35 | mW max |
| POWER REQUIREMENTS | | | |
| AV_{DD1} (Modulator Supply) | $\pm 5\%$ | +2.5 | V |
| AV_{DD2} (General Supply) | $\pm 5\%$ | +5 | V |
| AV_{DD3} (Diff Amp Supply) | | +3.15/+5.25 | V min/max |
| AV_{DD4} (Ref Buffer Supply) | | +3.15/+5.25 | V min/max |
| DV_{DD} | $\pm 5\%$ | +2.5 | V |
| V_{DRIVE} | | +1.65/+2.7 | V min/max |
| Normal Mode | | | |
| AI_{DD1} (Modulator) | | 49/51 | mA typ/max |
| AI_{DD2} (General) | | 40/42 | mA typ/max |
| AI_{DD4} (Reference Buffer) | $AV_{DD4} = 5\text{ V}$ | 34/36 | mA typ/max |
| Low Power Mode | | | |
| AI_{DD1} (Modulator) | | 26/28 | mA typ/max |
| AI_{DD2} (General) | | 20/23 | mA typ/max |
| AI_{DD4} (Reference Buffer) | $AV_{DD4} = 5\text{ V}$ | 9/10 | mA typ/max |
| AI_{DD3} (Diff Amp) | $AV_{DD3} = 5\text{ V}$, both modes | 41/44 | mA typ/max |
| DI_{DD} | Both modes | 63/70 | mA typ/max |
| DIGITAL I/O | | | |
| MCLK Input Amplitude ³ | | 5 | V typ |
| Input Capacitance | | 7.3 | pF typ |
| Input Leakage Current | | ± 5 | μA max |
| Three-State Leakage Current (D15:D0) | | ± 5 | μA max |
| V_{INH} | | $0.7 \times V_{DRIVE}$ | V min |
| V_{INL} | | $0.3 \times V_{DRIVE}$ | V max |
| V_{OH} ⁴ | | 1.5 | V min |
| V_{OL} ⁴ | | 0.1 | V max |

¹ See the Terminology section.

² SNR specifications in dBs are referred to a full-scale input, FS. Tested with an input signal at 0.5 dB below full scale, unless otherwise specified.

³ While the AD7762 can function with an MCLK amplitude of less than 5 V, this is the recommended amplitude to achieve the performance as stated.

⁴ Tested with a 400 μA load current.

TIMING SPECIFICATIONS

$AV_{DD1} = DV_{DD} = V_{DRIVE} = 2.5\text{ V}$, $AV_{DD2} = AV_{DD3} = AV_{DD4} = 5\text{ V}$, $T_A = 25^\circ\text{C}$, normal mode, unless otherwise noted.

Table 3.

| Parameter | Limit at T_{MIN} , T_{MAX} | Unit | Description |
|-------------|--|--------------------|--|
| f_{MCLK} | 1 40 | MHz min MHz max | Applied master clock frequency |
| f_{ICLK} | 500 20 | kHz min MHz max | Internal modulator clock derived from MCLK |
| $t_1^{1,2}$ | $0.5 \times t_{ICLK}$ | typ | \overline{DRDY} pulse width |
| t_2 | 10 | ns min | \overline{DRDY} falling edge to \overline{CS} falling edge |
| t_3 | 3 | ns min | $\overline{RD}/\overline{WR}$ setup time to \overline{CS} falling edge |
| t_4 | $(0.5 \times t_{ICLK}) + 16\text{ ns}$ | max | Data access time |
| t_5 | t_{ICLK} | min | \overline{CS} low read pulse width |
| t_6 | t_{ICLK} | min | \overline{CS} high pulse width between reads |
| t_7 | 3 | ns min | $\overline{RD}/\overline{WR}$ hold time to \overline{CS} rising edge |
| t_8 | 11 | ns max | Bus relinquish time |
| t_9 | $4 \times t_{ICLK}$ | min | \overline{CS} low write pulse width |
| t_{10} | $4 \times t_{ICLK}$ | min | \overline{CS} high period between address and data |
| t_{11} | 5 | ns min | Data setup time |
| t_{12} | 0 | ns min | Data hold time |

¹ $t_{ICLK} = 1/f_{ICLK}$.

² When $ICLK = MCLK$, \overline{DRDY} pulse width depends on the mark/space ratio of applied MCLK.

TIMING DIAGRAMS

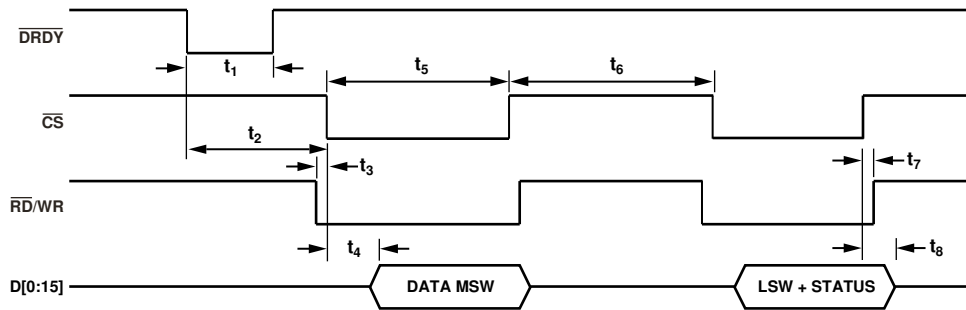

Figure 2. Parallel Interface Timing Diagram

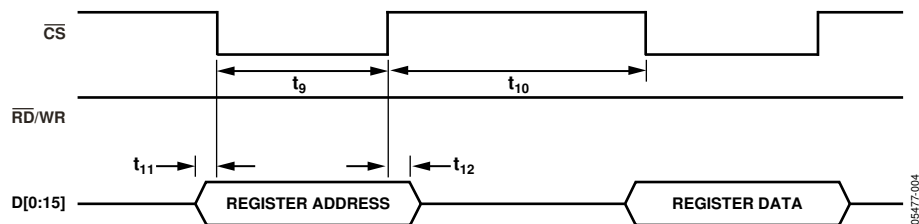

Figure 3. AD7762 Register Write

ABSOLUTE MAXIMUM RATINGS

$T_A = 25^\circ\text{C}$, unless otherwise noted.

Table 4.

| Parameters | Rating |
|--|------------------------------|
| AV_{DD1} to GND | -0.3 V to +3 V |
| AV_{DD2} - AV_{DD4} to GND | -0.3 V to +6 V |
| DV_{DD} to GND | -0.3 V to +3 V |
| V_{DRIVE} to GND | -0.3 V to +3 V |
| V_{IN+} , V_{IN-} to GND | -0.3 V to +6 V |
| Digital input voltage to GND ¹ | -0.3 V to $DV_{DD} + 0.3$ V |
| MCLK to MCLKGND | -0.3 V to +6 V |
| V_{REF} to GND ² | -0.3 V to $AV_{DD4} + 0.3$ V |
| AGND to DGND | -0.3 V to +0.3 V |
| Input Current to Any Pin Except Supplies ³ | ± 10 mA |
| Operating Temperature Range Commercial | -40°C to +85°C |
| Storage Temperature Range | -65°C to +150°C |
| Junction Temperature | 150°C |
| TQFP Exposed Paddle Package | |
| θ_{JA} Thermal Impedance | 92.7°C/W |
| θ_{JC} Thermal Impedance | 5.1°C/W |
| Lead Temperature, Soldering | |
| Vapor Phase (60 sec) | 215°C |
| Infrared (15 sec) | 220°C |
| ESD | 600 V |

¹ Absolute maximum voltage on digital inputs is 3.0 V or $DV_{DD} + 0.3$ V, whichever is lower.

² Absolute maximum voltage on V_{REF} input is 6.0 V or $AV_{DD4} + 0.3$ V, whichever is lower.

³ Transient currents of up to 200 mA do not cause SCR latch-up.

Stresses above those listed under Absolute Maximum Ratings may cause permanent damage to the device. This is a stress rating only; functional operation of the device at these or any other conditions above those listed in the operational sections of this specification is not implied. Exposure to absolute maximum rating conditions for extended periods may affect device reliability.

ESD CAUTION



ESD (electrostatic discharge) sensitive device.

Charged devices and circuit boards can discharge without detection. Although this product features patented or proprietary protection circuitry, damage may occur on devices subjected to high energy ESD. Therefore, proper ESD precautions should be taken to avoid performance degradation or loss of functionality.

PIN CONFIGURATION AND FUNCTION DESCRIPTIONS

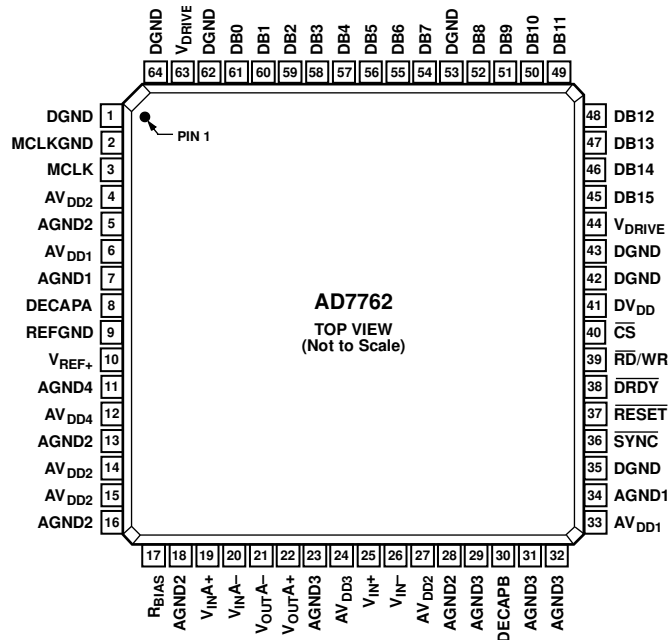

- NOTES**
 1. CONNECT THE EXPOSED PAD TO AGNDx WITH SIX TO EIGHT VIAS.

05477-005

Figure 4. 64-Lead TQFP Pin Configuration

Table 5. Pin Function Descriptions

| Pin No. | Mnemonic | Description |
|---------------------------|--------------------|--|
| 6, 33 | AV _{DD1} | 2.5 V Power Supply for Modulator. These pins should be decoupled to AGND1 with 100 nF and 10 μF capacitors on each pin. |
| 4, 14, 15, 27 | AV _{DD2} | 5 V Power Supply. These pins should be decoupled to AGND2 with 100 nF capacitors on each of Pin 4, Pin 14, and Pin 15. Pin 27 should be connected to Pin 14 via a 15 nH inductor. |
| 24 | AV _{DD3} | 3.3 V to 5 V Power Supply for Differential Amplifier. These pins should be decoupled to AGND3 with a 100 nF capacitor. |
| 12 | AV _{DD4} | 3.3 V to 5 V Power Supply for Reference Buffer. This pin should be decoupled to AGND4 with a 10 nF capacitor in series with a 10 Ω resistor. |
| 7, 34 | AGND1 | Power Supply Ground for Analog Circuitry Powered by AV _{DD1} . |
| 5, 13, 16, 18, 28 | AGND2 | Power Supply Ground for Analog Circuitry Powered by AV _{DD2} . |
| 23, 29, 31, 32 | AGND3 | Power Supply Ground for Analog Circuitry Powered by AV _{DD3} . |
| 11 | AGND4 | Power Supply Ground for Analog Circuitry Powered by AV _{DD4} . |
| 9 | REFGND | Reference Ground. Ground connection for the reference voltage. |
| 41 | DV _{DD} | 2.5 V Power Supply for Digital Circuitry and FIR Filter. This pin should be decoupled to DGND with a 100 nF capacitor. |
| 44, 63 | V _{DRIVE} | Logic Power Supply Input, 1.8 V to 2.5 V. The voltage supplied at these pins determines the operating voltage of the logic interface. Both these pins must be connected together and tied to the same supply. Each pin should also be decoupled to DGND with a 100 nF capacitor. |
| 1, 35, 42, 43, 53, 62, 64 | DGND | Ground Reference for Digital Circuitry. |
| 19 | V _{INA+} | Positive Input to Differential Amplifier. |
| 20 | V _{INA-} | Negative Input to Differential Amplifier. |
| 21 | V _{OUTA-} | Negative Output from Differential Amplifier. |
| 22 | V _{OUTA+} | Positive Output from Differential Amplifier. |
| 25 | V _{IN+} | Positive Input to the Modulator. |
| 26 | V _{IN-} | Negative Input to the Modulator. |

| Pin No. | Mnemonic | Description |
|-----------------------|---------------------------|--|
| 10 | V _{REF+} | Reference Input. The input range of this pin is determined by the reference buffer supply voltage (AV _{DD4}). See the Reference Voltage Filtering section for more details. |
| 8 | DECAPA | Decoupling Pin. A 100 nF capacitor must be inserted between this pin and AGND1. |
| 30 | DECAPB | Decoupling Pin. A 33 pF capacitor must be inserted between this pin and AGND3. |
| 17 | R _{BIAS} | Bias Current Setting Pin. A resistor must be inserted between this pin and AGND1. For more details, see the Bias Resistor Selection section. |
| 45 to 52, 54 to 61 | DB15 to DB8 DB7 to DB0 | 16-Bit Bidirectional Data Bus. These are three-state pins that are controlled by the \overline{CS} pin and the $\overline{RD/WR}$ pin. The operating voltage for these pins is determined by the V _{DRIVE} voltage. See the AD7762 Interface section for more details. |
| 37 | \overline{RESET} | A falling edge on this pin resets all internal digital circuitry and powers down the part. Holding this pin low keeps the AD7762 in a reset state. |
| 3 | MCLK | Master Clock Input. A low jitter digital clock must be applied to this pin. The output data rate depends on the frequency of this clock. See the section Clocking the AD7762 for more details. |
| 2 | MCLKGND | Master Clock Ground Sensing Pin. |
| 36 | \overline{SYNC} | Synchronization Input. A falling edge on this pin resets the internal filter. This can be used to synchronize multiple devices in a system. |
| 39 | $\overline{RD/WR}$ | Read/Write Input. This pin, in conjunction with the chip select pin, is used to read and write data to and from the AD7762. If this pin is low when \overline{CS} is low, a read takes place. If this pin is high and \overline{CS} is low, a write occurs. See the AD7762 Interface section for more details. |
| 38 | \overline{DRDY} | Data Ready Output. Each time that new conversion data is available, an active low pulse, ½ ICLK period wide, is produced on this pin. See the AD7762 Interface section for more details. |
| 40 | \overline{CS} | Chip Select Input. Used in conjunction with the $\overline{RD/WR}$ pin to read and write data to and from the AD7762. See the AD7762 Interface section for more details. |
| | EPAD | Exposed pad. Connect the exposed pad to AGNDx with six to eight vias. |

TERMINOLOGY

Signal-to-Noise Ratio (SNR)

SNR is the ratio of the rms value of the actual input signal to the rms sum of all other spectral components below the Nyquist frequency, excluding harmonics and dc. The value for SNR is expressed in decibels.

Total Harmonic Distortion (THD)

The ratio of the rms sum of harmonics to the fundamental. For the AD7762, it is defined as

$$THD(\text{dB}) = 20 \log \frac{\sqrt{V_2^2 + V_3^2 + V_4^2 + V_5^2 + V_6^2}}{V_1}$$

where:

V_1 is the rms amplitude of the fundamental.

$V_2, V_3, V_4, V_5,$ and V_6 are the rms amplitudes of the second to the sixth harmonics.

Nonharmonic Spurious-Free Dynamic Range (SFDR)

The ratio of the rms signal amplitude to the rms value of the peak spurious spectral component, excluding harmonics.

Dynamic Range

Dynamic range is the ratio of the rms value of the full scale to the rms noise measured with the inputs shorted together. The value for dynamic range is expressed in decibels.

Integral Nonlinearity (INL)

The maximum deviation from a straight line passing through the endpoints of the ADC transfer function.

Differential Nonlinearity (DNL)

The difference between the measured and the ideal 1-LSB change between any two adjacent codes in the ADC.

Zero Error

The zero error is the difference between the ideal midscale input voltage (0 V) and the actual voltage producing the midscale output code.

Zero Error Drift

The change in the actual zero error value due to a temperature change of 1°C. It is expressed as a percentage of the zero error at room temperature.

Gain Error

The first transition (from 100...000 to 100...001) should occur for an analog voltage 1/2 LSB above the nominal negative full scale. The last transition (from 011...110 to 011...111) should occur for an analog voltage 1 1/2 LSB below the nominal full scale. The gain error is the deviation of the difference between the actual level of the last transition and the actual level of the first transition, from the difference between the ideal levels.

Gain Error Drift

The change in the actual gain error value due to a temperature change of 1°C. It is expressed as a percentage of the gain error at room temperature.

TYPICAL PERFORMANCE CHARACTERISTICS

$AV_{DD1} = DV_{DD} = V_{DRIVE} = 2.5\text{ V}$, $AV_{DD2} = AV_{DD3} = AV_{DD4} = 5\text{ V}$, $V_{REF} = 4.096\text{ V}$, $T_A = 25^\circ\text{C}$, normal mode, unless otherwise noted. All FFTs are generated from 65,536 samples using a 7-term Blackman-Harris window.

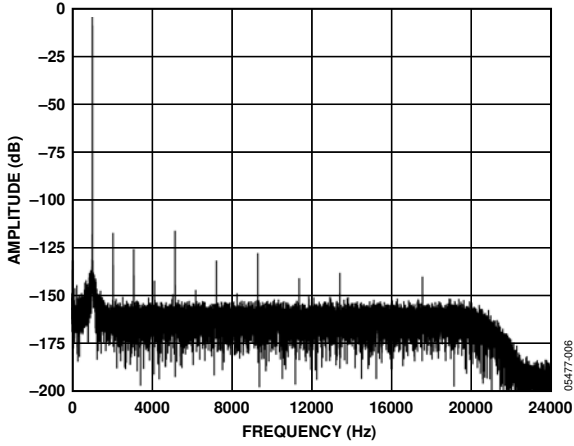

Figure 5. Normal Mode FFT, 1 kHz, -0.5 dB Input Tone, 256x Decimation

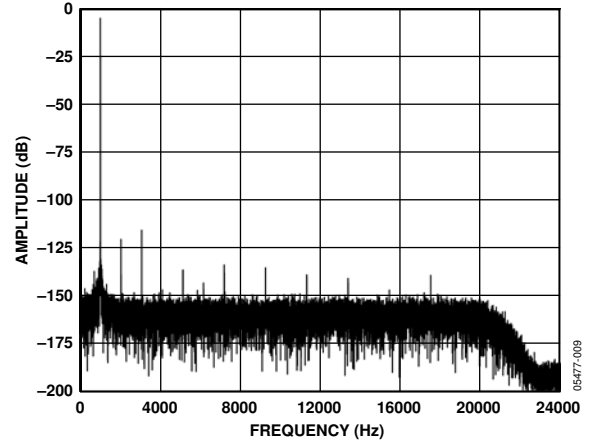

Figure 8. Low Power FFT, 1 kHz, -0.5 dB Input Tone, 256x Decimation

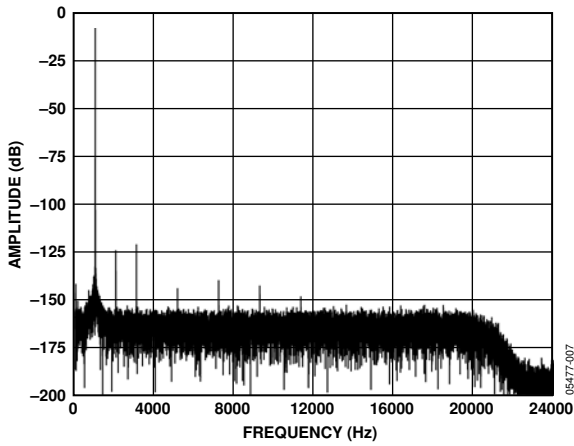

Figure 6. Normal Mode FFT, 1 kHz, -6 dB Input Tone, 256x Decimation

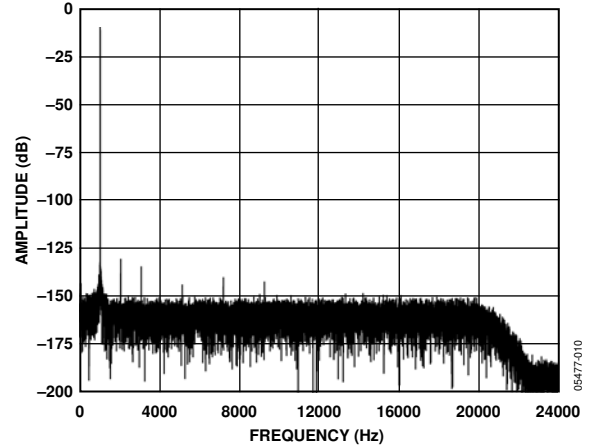

Figure 9. Low Power FFT, 1 kHz, -6 dB Input Tone, 256x Decimation

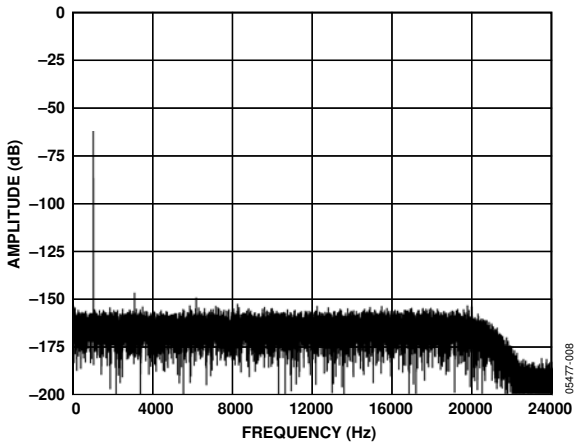

Figure 7. Normal Mode FFT, 1 kHz, -60 dB Input Tone, 256x Decimation

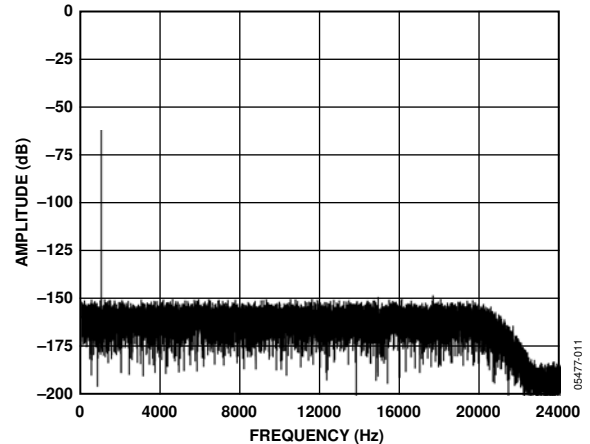

Figure 10. Low Power FFT, 1 kHz, -60 dB Input Tone, 256x Decimation

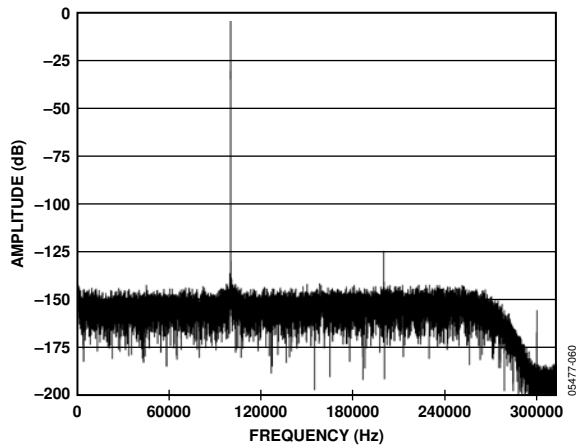

Figure 11. Normal Mode FFT, 100 kHz, -0.5 dB Input Tone, 32x Decimation

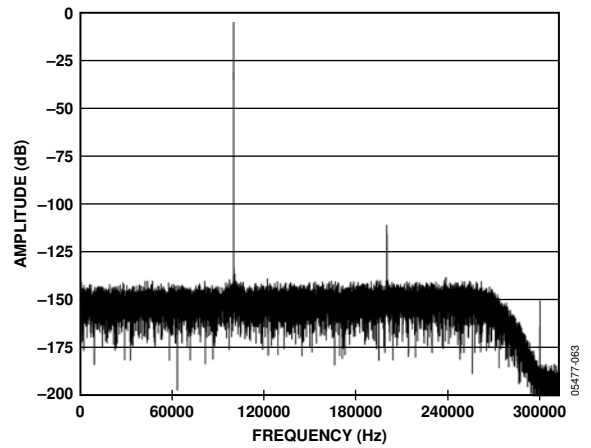

Figure 14. Low Power FFT, 100 kHz, -0.5 dB Input Tone, 32x Decimation

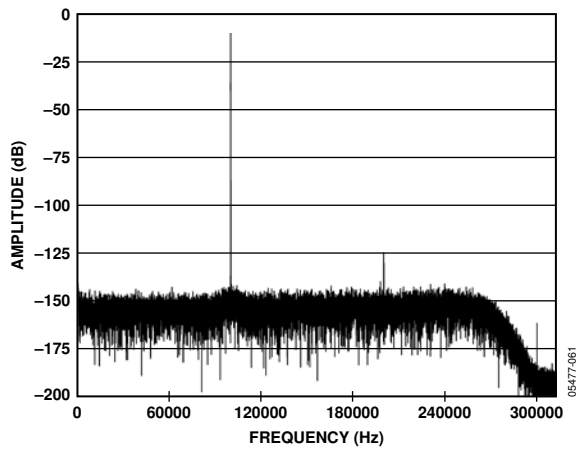

Figure 12. Normal Mode FFT, 100 kHz, -6 dB Input Tone, 32x Decimation

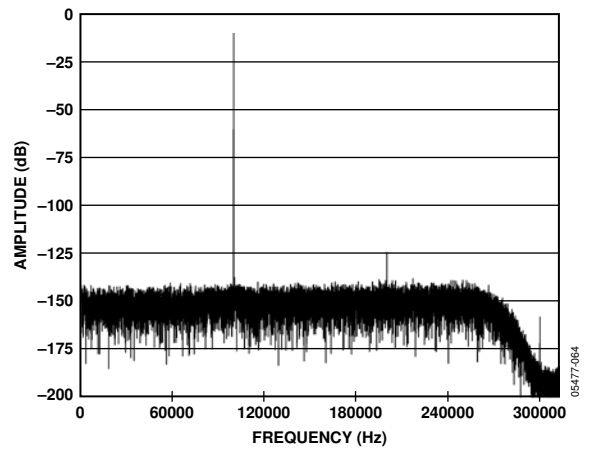

Figure 15. Low Power FFT, 100 kHz, -6 dB Input Tone, 32x Decimation

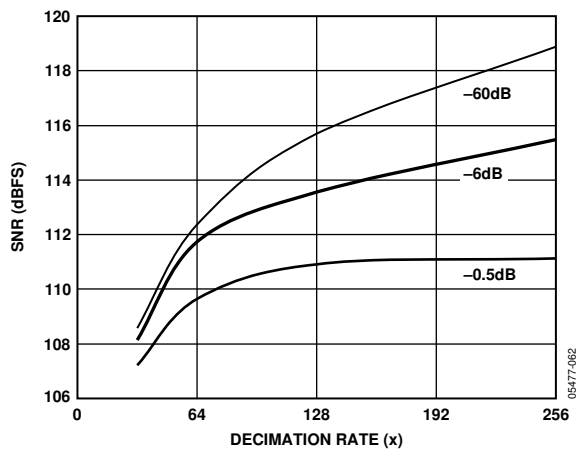

Figure 13. Normal Mode SNR vs. Decimation Rate, 1 kHz Input Tone

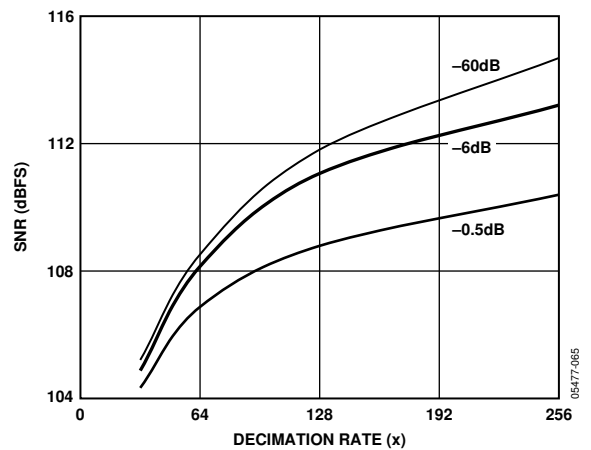

Figure 16. Low Power SNR vs. Decimation Rate, 1 kHz Input Tone

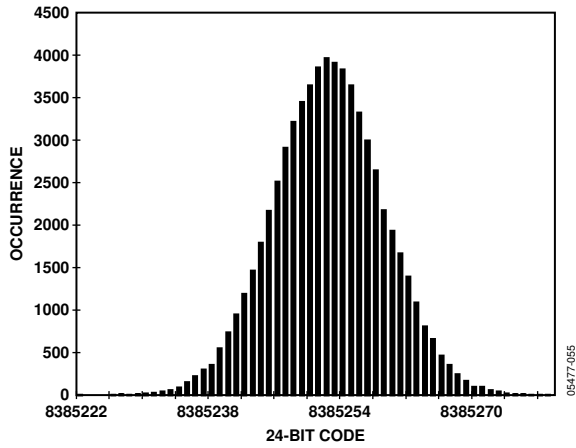

Figure 17. Normal Mode, 24-Bit Histogram, 256x Decimation

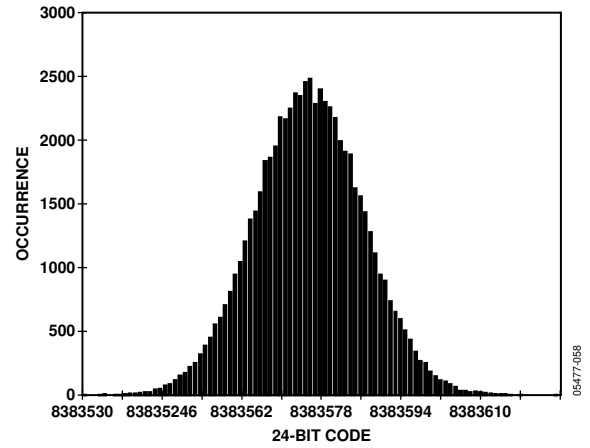

Figure 20. Low Power, 24-Bit Histogram, 256x Decimation

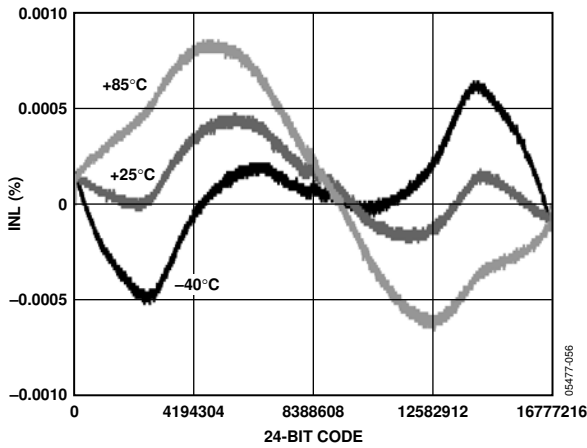

Figure 18. 24-Bit INL, Normal Mode

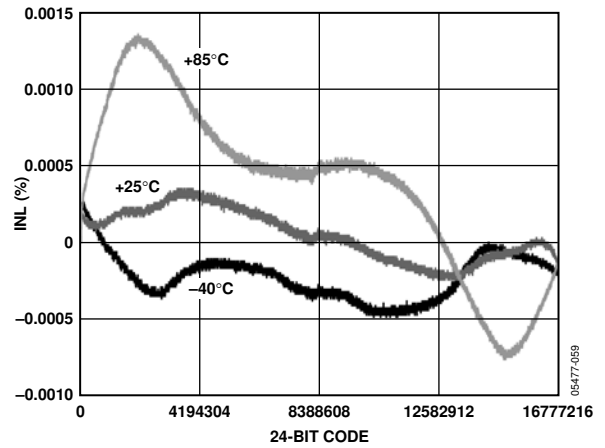

Figure 21. 24-Bit INL, Low Power Mode

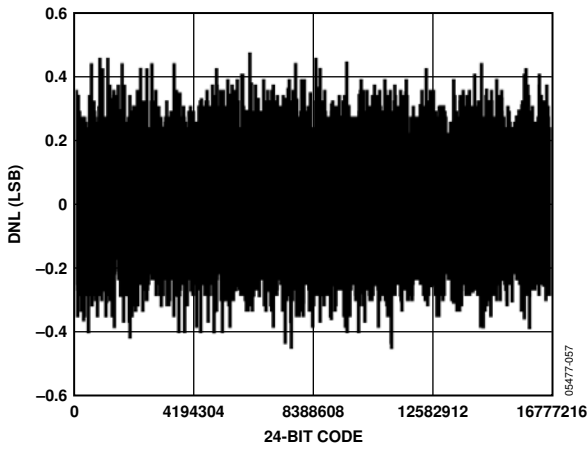

Figure 19. 24-Bit DNL

THEORY OF OPERATION

The AD7762 employs a Σ - Δ conversion technique to convert the analog input into an equivalent digital word. The modulator samples the input waveform and outputs an equivalent digital word to the digital filter at a rate equal to ICLK.

Due to the high oversampling rate, that spreads the quantization noise from 0 to f_{ICLK} , the noise energy contained in the band of interest is reduced (Figure 22 a). To further reduce the quantization noise, a high order modulator is employed to shape the noise spectrum; so that most of the noise energy is shifted out of the band of interest (Figure 22 b).

The digital filtering that follows the modulator removes the large out-of-band quantization noise (Figure 22 c) while also reducing the data rate from f_{ICLK} at the input of the filter to $f_{\text{ICLK}}/8$ or less at the output of the filter, depending on the decimation rate used.

Digital filtering has certain advantages over analog filtering. It does not introduce significant noise or distortion and can be made perfectly linear phase.

The AD7762 employs three FIR filters in series. By using different combinations of decimation ratios and filter selection and bypassing, data can be obtained from the AD7762 at a large range of data rates. The first filter receives data from the modulator at ICLK MHz where it is decimated by four to output data at ICLK/4 MHz. This partially filtered data can also be output at this stage. The second filter allows the decimation

rate to be chosen from 4 \times to 32 \times . The third filter has a fixed decimation rate of 2 \times , is user programmable, and has a default configuration. It is described in detail in the Programmable FIR Filter section. This filter can be bypassed.

Table 6 lists some characteristics of the default filter. The group delay of the filter is defined to be the delay to the center of the impulse response and is equal to the computation + filter delays. The delay until valid data is available (the DVALID status bit is set) is equal to 2 \times the filter delay + the computation delay.

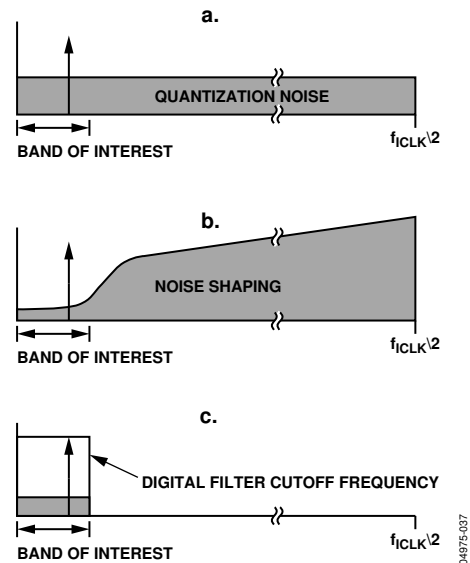

Figure 22. Σ - Δ ADC

Table 6. Configuration with Default Filter

| ICLK Frequency | Filter 1 | Filter 2 | Filter 3 | Data State | Computation Delay | Filter Delay | Pass-Band Bandwidth | Output Data Rate (ODR) |
|----------------|------------|-------------|------------|--------------------|-------------------|---------------|---------------------|------------------------|
| 20 MHz | 4 \times | 4 \times | 2 \times | Fully filtered | 1.775 μ s | 44.4 μ s | 250 kHz | 625 kHz |
| 20 MHz | 4 \times | 8 \times | Bypassed | Partially filtered | 2.6 μ s | 10.8 μ s | 140.625 kHz | 625 kHz |
| 20 MHz | 4 \times | 8 \times | 2 \times | Fully filtered | 2.25 μ s | 87.6 μ s | 125 kHz | 312.5 kHz |
| 20 MHz | 4 \times | 16 \times | Bypassed | Partially filtered | 4.175 μ s | 20.4 μ s | 70.3125 kHz | 312.5 kHz |
| 20 MHz | 4 \times | 16 \times | 2 \times | Fully filtered | 3.1 μ s | 174 μ s | 62.5 kHz | 156.25 kHz |
| 20 MHz | 4 \times | 32 \times | Bypassed | Partially filtered | 7.325 μ s | 39.6 μ s | 35.156 kHz | 156.25 kHz |
| 20 MHz | 4 \times | 32 \times | 2 \times | Fully filtered | 4.65 μ s | 346.8 μ s | 31.25 kHz | 78.125 kHz |
| 12.288 MHz | 4 \times | 8 \times | 2 \times | Fully filtered | 3.66 μ s | 142.6 μ s | 76.8 kHz | 192 kHz |
| 12.288 MHz | 4 \times | 16 \times | 2 \times | Fully filtered | 5.05 μ s | 283.2 μ s | 38.4 kHz | 96 kHz |
| 12.288 MHz | 4 \times | 32 \times | Bypassed | Partially filtered | 11.92 μ s | 64.45 μ s | 21.6 kHz | 96 kHz |
| 12.288 MHz | 4 \times | 32 \times | 2 \times | Fully filtered | 7.57 μ s | 564.5 μ s | 19.2 kHz | 48 kHz |

AD7762 INTERFACE

READING DATA

The AD7762 uses a 16-bit bidirectional parallel interface. This interface is controlled by the $\overline{\text{RD}}/\overline{\text{WR}}$ and $\overline{\text{CS}}$ pins.

When a new conversion result is available, an active low pulse is output on the $\overline{\text{DRDY}}$ pin. To read a conversion result from the AD7762, two 16-bit read operations are performed. The $\overline{\text{DRDY}}$ pulse indicates that a new conversion result is available. Both $\overline{\text{RD}}/\overline{\text{WR}}$ and $\overline{\text{CS}}$ go low to perform the first read operation. Shortly after both these lines go low, the data bus becomes active and the 16 most significant bits (MSBs) of the conversion result are output. The $\overline{\text{RD}}/\overline{\text{WR}}$ and $\overline{\text{CS}}$ lines must return high for a full ICLK period before the second read is performed. This second read contains the 8 least significant bits (LSBs) of the conversion result along with 6 status bits. These status bits are shown in Table 7. Descriptions of the other status bits are in Table 15.

Table 7. Status Bits During Data Read

| D7 | | | | | | | D0 | |
|--------|-----|-------|------|--------|------|---|----|--|
| DValid | Ovr | UFilt | LPwr | FiltOk | DLOk | 0 | 0 | |

Shortly after $\overline{\text{RD}}/\overline{\text{WR}}$ and $\overline{\text{CS}}$ return high, the data bus returns to a high impedance state. Both read operations must be completed before a new conversion result is available because the new result overwrites the contents on the output register. If a $\overline{\text{DRDY}}$ pulse occurs during a read operation, the data read is invalid.

SHARING THE PARALLEL BUS

By its nature, the high accuracy of the AD7762 makes it sensitive to external noise sources. These include digital activity on the parallel bus. For this reason, it is recommended that the AD7762 data lines are isolated from the system data bus by means of a latch or buffer to ensure that there is no digital activity on the D0 to D15 pins that is not controlled by the AD7762. If multiple, synchronized AD7762 parts that share a properly distributed common MCLK signal exist in a system, these parts can share a common bus without being isolated from each other. This bus can then be isolated from the system bus by a single latch or buffer.

WRITING TO THE AD7762

While the AD7762 is configured to convert analog signals with the default settings on reset, there are many features and parameters on this part that the user can change by writing to the device. Because some of the programmable registers are 16 bits wide, two write operations are required to program a register. The first write contains the register address while the second write contains the register data. An exception is when a user filter is being downloaded to the AD7762. This is described in detail in the Downloading a User-Defined Filter section. The AD7762 Registers section contains the register addresses and more details.

Figure 3 shows a write operation to the AD7762. The $\overline{\text{RD}}/\overline{\text{WR}}$ line is held high while the $\overline{\text{CS}}$ line is brought low for a minimum of 4 ICLK periods. The register address is latched during this period. The $\overline{\text{CS}}$ line is brought high again for a minimum of 4 ICLK periods before the register data is put onto the data bus. If a read operation occurs between the writing of the register address and the register data, the register address is cleared and the next write must be the register address again. This also provides a method to get back to a known situation if the user forgets whether the next write is an address or data.

Generally, the AD7762 is written to and configured on power-up and very infrequently, if at all, after that. Following any write operation, the full group delay of the filter must pass before valid data is output from the AD7762.

READING STATUS AND OTHER REGISTERS

The AD7762 features a number of programmable registers. To read back the contents of these registers or the status register, the user must first write to the control register of the device, setting a bit corresponding to the register to be read. The next read operation outputs the contents of the selected register instead of a conversion result. The AD7762 Registers section provides more information on the relevant bits in the control register.

CLOCKING THE AD7762

The AD7762 requires an external low jitter clock source. This signal is applied to the MCLK pin, and the MCLKGND pin is used to sense the ground from the clock source. An internal clock signal (ICLK) is derived from the MCLK input signal. The ICLK controls the internal operations of the AD7762. The maximum ICLK frequency is 20 MHz, but due to an internal clock divider, a range of MCLK frequencies can be used. There are two ways to generate the ICLK:

$$ICLK = MCLK (\overline{CDIV} = 1)$$

$$ICLK = MCLK/2 (\overline{CDIV} = 0)$$

These options are selected from the control register (see the AD7762 Registers section for more details). On power-up, the default is $ICLK = MCLK/2$ to ensure that the part can handle the maximum MCLK frequency of 40 MHz. For output data rates equal to those used in audio systems, a 12.288 MHz ICLK frequency can be used. As shown in Table 6, output data rates of 192 kHz, 96 kHz, and 48 kHz are achievable with this ICLK frequency. As mentioned previously, this ICLK frequency can be derived from different MCLK frequencies.

The MCLK jitter requirements depend on a number of factors and are given by

$$t_{j(rms)} = \frac{\sqrt{OSR}}{2 \times \pi \times f_{IN} \times 10^{\frac{SNR(dB)}{20}}}$$

where:

$$OSR = \text{Over-sampling ratio} = \frac{f_{ICLK}}{ODR}$$

f_{IN} = Maximum input frequency

SNR(dB) = Target SNR

EXAMPLE 1

This example can be taken from Table 6, where:

$$ODR = 625 \text{ kHz}$$

$$f_{ICLK} = 20 \text{ MHz}$$

$$f_{IN} (\text{max}) = 250 \text{ kHz}$$

$$SNR = 108 \text{ dB}$$

$$t_{j(rms)} = \frac{\sqrt{32}}{2 \times \pi \times 250 \times 10^3 \times 10^6} = 3.6 \text{ ps}$$

This is the maximum allowable clock jitter for a full-scale, 250 kHz input tone with the given ICLK and output data rate.

EXAMPLE 2

Take a second example from Table 6, where:

$$ODR = 48 \text{ kHz}$$

$$f_{ICLK} = 12.288 \text{ MHz}$$

$$f_{IN} (\text{max}) = 19.2 \text{ kHz}$$

$$SNR = 120 \text{ dB}$$

$$t_{j(rms)} = \frac{\sqrt{256}}{2 \times \pi \times 19.2 \times 10^3 \times 10^6} = 133 \text{ ps}$$

The input amplitude also has an effect on these jitter figures. If, for example, the input level was 3 dB below full scale, the allowable jitter would be increased by a factor of $\sqrt{2}$, increasing the first example to 2.53 ps rms. This happens when the maximum slew rate is decreased by a reduction in amplitude. Figure 23 and Figure 24 illustrate this point, showing the maximum slew rate of a sine wave of the same frequency but with different amplitudes.

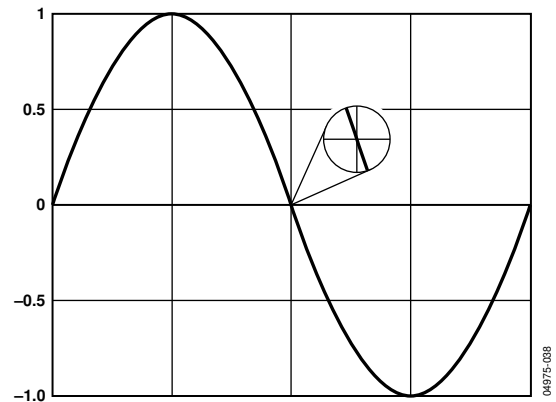

Figure 23. Maximum Slew Rate of Sine Wave with Amplitude of 2 V p-p

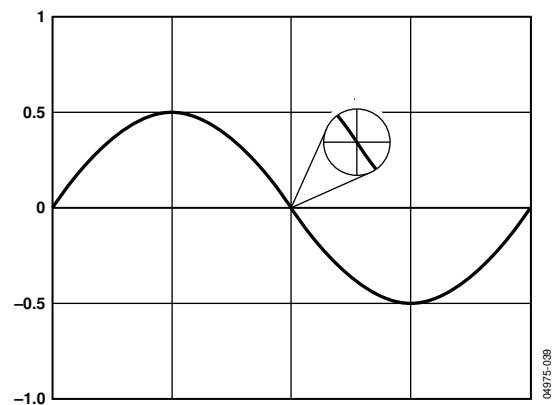

Figure 24. Maximum Slew Rate of Same Frequency Sine Wave with Amplitude of 1 V p-p

DRIVING THE AD7762

The AD7762 has an on-chip differential amplifier that operates with a supply voltage (AV_{DD3}) from 3.15 V to 5.25 V. For a 4.096 V reference, the supply voltage must be 5 V.

To achieve the specified performance in normal mode, the differential amplifier should be configured as a first-order antialias filter, as shown in Figure 25. Any additional filtering should be carried out in previous stages using low noise, high performance op amps, such as the AD8021.

Suitable component values for the first-order filter are listed in Table 8. The values in Table 8 yield a 10 dB attenuation at the first alias point of 19 MHz.

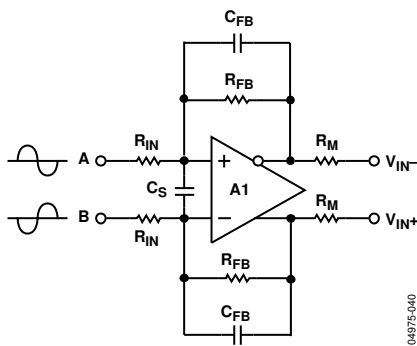

Figure 25. Differential Amplifier Configuration

Table 8. Normal Mode Component Values

| V_{REF} | R_{IN} | R_{FB} | R_M | C_S | C_{FB} |
|-----------|--------------|--------------|-------------|--------|----------|
| 4.096 V | 1 k Ω | 655 Ω | 18 Ω | 5.6 pF | 33 pF |

Figure 26 shows the signal conditioning that occurs using the circuit in Figure 25 with a ± 2.5 V input signal biased around ground and having the component values and conditions in Table 8. The differential amplifier always biases the output signal to sit on the optimum common mode of $V_{REF}/2$, in this case 2.048 V. The signal is also scaled to give the maximum allowable voltage swing with this reference value. This is calculated as 80% of V_{REF} , that is, $0.8 \times 4.096 \text{ V} \approx 3.275 \text{ V p-p}$ on each input.

To obtain maximum performance from the AD7762, it is advisable to drive the ADC with differential signals. Figure 27 shows how a bipolar, single-ended signal biased around ground can drive the AD7762 with the use of an external op amp, such as the AD8021.

With a 4.096 V reference, a 5 V supply must be provided to the reference buffer (AV_{DD4}). With a 2.5 V reference, a 3.3 V supply must be provided to AV_{DD4} .

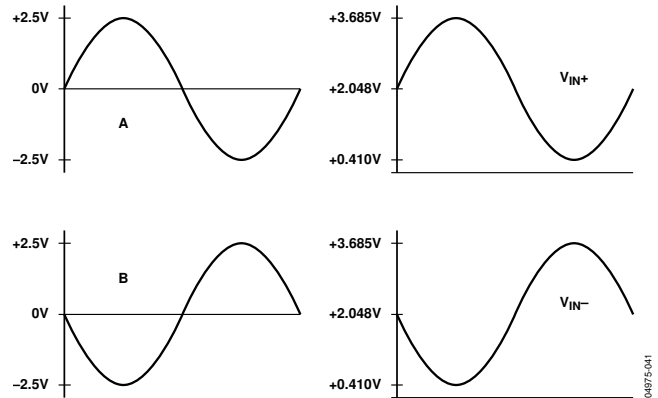

Figure 26. Differential Amplifier Signal Conditioning

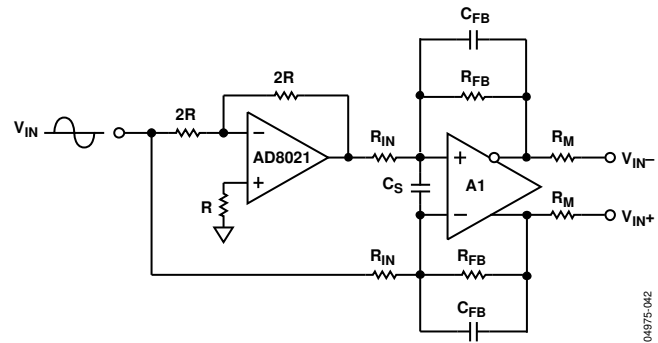

Figure 27. Single-Ended-to-Differential Conversion

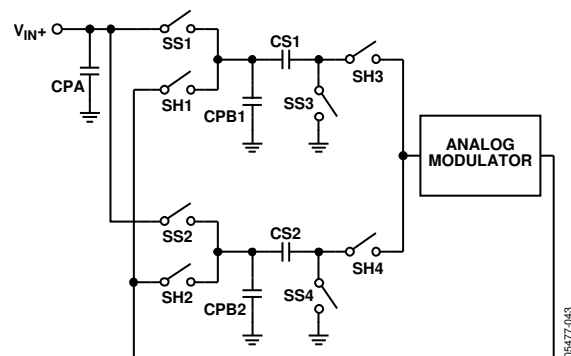

Figure 28. Equivalent Input Circuit

The AD7762 employs a double sampling front end, as shown in Figure 28. For simplicity, only the equivalent input circuit for V_{IN+} is shown. The equivalent input circuitry for V_{IN-} is the same.

The sampling switches SS1 and SS3 are driven by $\overline{\text{ICLK}}$, whereas the sampling switches SS2 and SS4 are driven by ICLK . When ICLK is high, the analog input voltage is connected to CS1. On the falling edge of ICLK , the SS1 and SS3 switches open, and the analog input is sampled on CS1. Similarly, when ICLK is low, the analog input voltage is connected to CS2. On the rising edge of ICLK , the SS2 and SS4 switches open, and the analog input is sampled on CS2.

Capacitors CPA, CPB1, and CPB2 represent parasitic capacitances that include the junction capacitances associated with the MOS switches.

Table 9. Equivalent Component Values

| Mode | CS1 | CS2 | CPA | CPB1/2 |
|-----------|-------|-------|-------|--------|
| Normal | 51 pF | 51 pF | 12 pF | 20 pF |
| Low Power | 13 pF | 13 pF | 12 pF | 5 pF |

USING THE AD7762

The following is the recommended sequence for powering up and using the AD7762.

1. Apply power.
2. Start the clock oscillator, applying MCLK.
3. Take $\overline{\text{RESET}}$ low for a minimum of 1 MCLK cycle.
4. Wait a minimum of 2 MCLK cycles after $\overline{\text{RESET}}$ has been released.
5. Write to Control Register 2 to power up the ADC and the differential amplifier as required. The correct clock divider ($\overline{\text{CDIV}}$) ratio should be programmed now.
6. Write to Control Register 1 to set the output data rate.
7. Wait a minimum of 5 MCLK cycles after $\overline{\text{CS}}$ has been released.
8. Take $\overline{\text{SYNC}}$ low for a minimum of 4 MCLK cycles, if required, to synchronize multiple parts.

Data can then be read from the part using the default filter, offset, gain, and overrange threshold values. The conversion data read is not valid, however, until the group delay of the filter has passed. When this has occurred, the DVALID bit read with the data LSW is set, indicating that the data is indeed valid.

The user can then download a different filter, if required (see Downloading a User-Defined Filter). Values for gain, offset, and overrange threshold registers can be written or read at this stage.

BIAS RESISTOR SELECTION

The AD7762 requires a resistor to be connected between the R_{BIAS} pin and AGND1. The value for this resistor is dependant on the reference voltage being applied to the device. The resistor value should be selected to give a current of 25 μA through the resistor to ground. For a 2.5 V reference voltage, the correct resistor value is 100 k Ω and for a 4.096 V reference, the correct resistor value is 160 k Ω .

DECOUPLING AND LAYOUT RECOMMENDATIONS

Due to the high performance nature of the AD7762, correct decoupling and layout techniques are required to obtain the performance as stated within this datasheet. Figure 29 shows a simplified connection diagram for the AD7762.

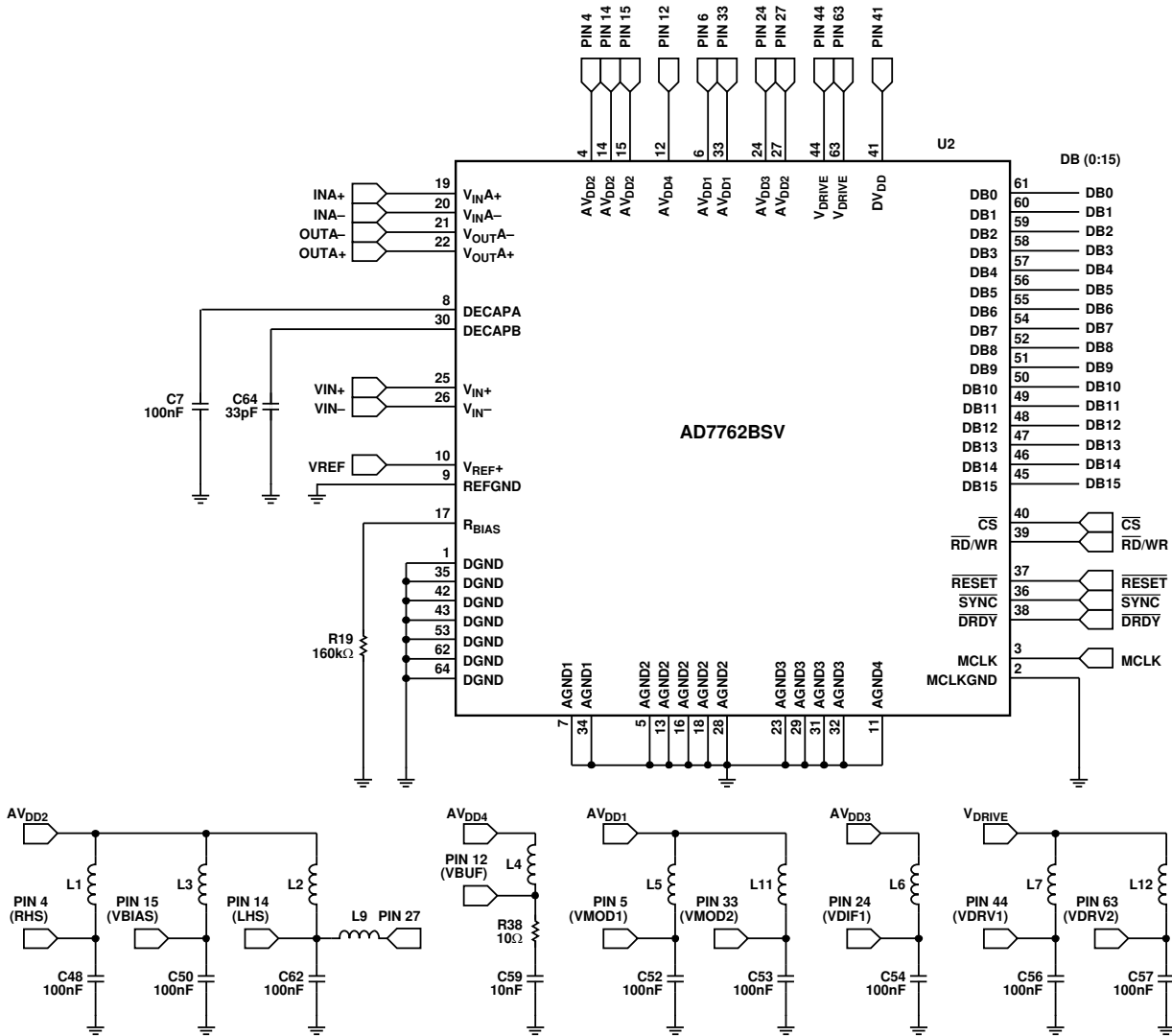

Figure 29. Simplified Connection Diagram

SUPPLY DECOUPLING

Every supply pin must be connected to the appropriate supply via a ferrite bead and decoupled to the correct ground pin with a 100 nF, 0603 case size, X7R dielectric capacitor. There are two exceptions to this:

- Pin 12 (AV_{DD4}) must have a 10 Ω resistor inserted between the pin and a 10 nF decoupling capacitor.
- Pin 27 (AV_{DD2}) does not require a separate decoupling capacitor or a direct connection to the supply, but instead is connected to Pin 14 via a 15 nH inductor.

ADDITIONAL DECOUPLING

There are two other decoupling pins on the AD7762—Pin 8 (DECAPA) and Pin 30 (DECAPB). Pin 8 should be decoupled with a 100 nF capacitor, and Pin 30 requires a 33 pF capacitor.

REFERENCE VOLTAGE FILTERING

A low noise reference source, such as the ADR431 (2.5 V) or ADR434 (4.096 V), is suitable for use with the AD7762. The reference voltage supplied to the AD7762 should be decoupled and filtered, as shown in Figure 30.

The recommended scheme for the reference voltage supply is a 100 Ω series resistor connected to a 100 μ F tantalum capacitor, followed by series resistor of 10 Ω , and finally a 10 nF decoupling capacitor very close to the V_{REF+} pin.

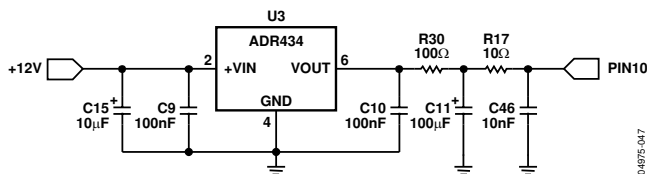

Figure 30. Reference Connection

DIFFERENTIAL AMPLIFIER COMPONENTS

The correct components for use around the on-chip differential amplifier are detailed in Table 8. Matching the components on both sides of the differential amplifier is important to minimize distortion of the signal applied to the amplifier. A tolerance of 0.1% or better is required for these components. Symmetrical routing of the tracks on both sides of the differential amplifier also assists in achieving stated performance.

LAYOUT CONSIDERATIONS

While using the correct components is essential to achieve optimum performance, the correct layout is just as important. The Design Tools section of the AD7762 product page on the Analog Devices website contains the gerber files for the AD7762 evaluation board. These files should be used as a reference when designing any system using the AD7762.

The location and orientation of some of the components mentioned in previous sections is critical, and particular attention must be paid to the components which are located close to the AD7762. Locating these components further away from the devices can have a direct impact on the maximum performance achievable.

The use of ground planes also should be carefully considered. To ensure that the return currents through the decoupling capacitors are flowing to the correct ground pin, the ground side of the capacitors should be as close to the ground pin associated with that supply. A ground plane should not be relied on as the sole return path for decoupling capacitors because the return current path using ground planes is not easily predictable.

PROGRAMMABLE FIR FILTER

As previously mentioned, the third FIR filter on the AD7762 is user programmable. The default coefficients that are loaded on reset are given in Table 10 and the frequency responses are shown in Figure 31. The frequencies quoted in Figure 31 scale directly with the output data rate.

Table 10. Default Filter Coefficients

| No. | Dec. Value | Hex Value | No. | Dec. Value | Hex Value |
|-----|------------|-----------|-----|------------|-----------|
| 0 | 53656736 | 332BCA0 | 24 | 700847 | AB1AF |
| 1 | 25142688 | 17FA5A0 | 25 | -70922 | 401150A |
| 2 | -4497814 | 444A196 | 26 | -583959 | 408E917 |
| 3 | -11935847 | 4B62067 | 27 | -175934 | 402AF3E |
| 4 | -1313841 | 4140C31 | 28 | 388667 | 5EE3B |
| 5 | 6976334 | 6A734E | 29 | 294000 | 47C70 |
| 6 | 3268059 | 31DDDB | 30 | -183250 | 402CBD2 |
| 7 | -3794610 | 439E6B2 | 31 | -302597 | 4049E05 |
| 8 | -3747402 | 4392E4A | 32 | 16034 | 3EA2 |
| 9 | 1509849 | 1709D9 | 33 | 238315 | 3A2EB |
| 10 | 3428088 | 344EF8 | 34 | 88266 | 158CA |
| 11 | 80255 | 1397F | 35 | -143205 | 4022F65 |
| 12 | -2672124 | 428C5FC | 36 | -128919 | 401F797 |
| 13 | -1056628 | 4101F74 | 37 | 51794 | CA52 |
| 14 | 1741563 | 1A92FB | 38 | 121875 | 1DC13 |
| 15 | 1502200 | 16EBF8 | 39 | 16426 | 402A |
| 16 | -835960 | 40CC178 | 40 | -90524 | 401619C |
| 17 | -1528400 | 4175250 | 41 | -63899 | 400F99B |
| 18 | 93626 | 16DBA | 42 | 45234 | B0B2 |
| 19 | 1269502 | 135EFE | 43 | 114720 | 1C020 |
| 20 | 411245 | 6466D | 44 | 102357 | 18FD5 |
| 21 | -864038 | 40D2F26 | 45 | 52669 | CDBD |
| 22 | -664622 | 40A242E | 46 | 15559 | 3CC7 |
| 23 | 434489 | 6A139 | 47 | 1963 | 7AB |

The default filter should be sufficient for almost all applications. It is a standard brick wall filter with a symmetrical impulse response. The default filter has a length of 96 taps in non-aliasing with 120 dB of attenuation at Nyquist. This filter not only performs signal antialiasing, but also suppresses out-of-band quantization noise produced by the analog-to-digital conversion process. Any significant relaxation in the stop-band attenuation or transition bandwidth relative to the default filter can result in a failure to meet the SNR specifications.

To create a filter, note the following:

- The filter must be even, symmetrical FIR.
- The coefficients are in sign-and-magnitude format with 26 magnitude bits and sign coded as positive = 0.
- The filter length must be between 12 taps and 96 taps in steps of 12.
- Because the filter is symmetrical, the number of coefficients that must be downloaded is half the filter length. The default filter coefficients exemplify this with only 48 coefficients listed for a 96-tap filter.
- Coefficients are written from the center of impulse response (adjacent to the point of symmetry) outwards.
- The coefficients are scaled so that the in-band gain of the filter is equal to 134217726 with the coefficients rounded to the nearest integer. For a low-pass filter, this is the equivalent of having the coefficients sum arithmetically (including sign) to a 67108863 (0x3FF FFFF) positive value over the half-impulse response coefficient set (maximum 48 coefficients). Any deviation from this introduces a gain error.

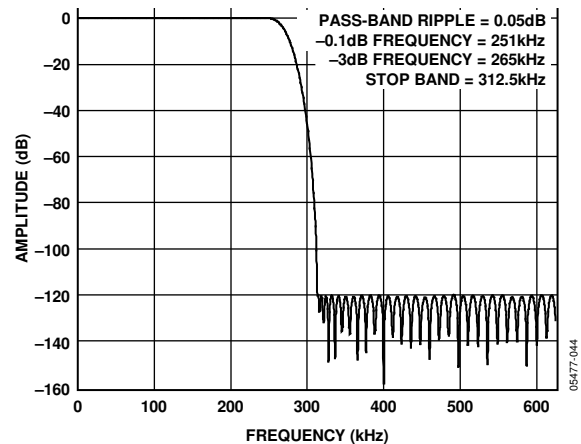

Figure 31. Default Filter Frequency Response (625 kHz ODR)

The procedure for downloading a user-defined filter is detailed in the Downloading a User-Defined Filter section.

DOWNLOADING A USER-DEFINED FILTER

As previously mentioned, the filter coefficients are 27 bits in length; 1 sign and 26 magnitude bits. Because the AD7762 has a 16-bit parallel bus, the coefficients are padded with 5 MSB 0s to generate a 32-bit word and split into two 16-bit words for downloading. The first 16-bit word for each coefficient becomes (00000, Sign bit, Magnitude [25:16]), while the second word becomes (Magnitude [15:0]). To ensure that a filter is down-loaded correctly, a checksum must also be generated and then downloaded following the final coefficient. The checksum is a 16-bit word generated by splitting each 32-bit word into 4 bytes and summing all bytes from all coefficients up to a maximum of 192 bytes (48 coefficients × 4 bytes). The same checksum is generated internally in the AD7762 and compared with the checksum downloaded. The DL_OK bit in the status register is set if these two checksums agree.

To download a user filter:

1. Write to Control Register 1, setting the DL_Filt bit and also the correct filter length bits corresponding to the length of the filter to be downloaded (see Table 11).
2. Write the first half of the current coefficient data (00000, Sign bit, Magnitude [25:16]). The first coefficient to be written must be the one adjacent to the point of filter symmetry.
3. Write the second half of the current coefficient data (Magnitude [15:0]).
4. Repeat Step 2 and Step 3 for each coefficient.
5. Write the 16-bit checksum.
6. Use these methods to verify that the filter coefficients are downloaded correctly:
 - a. Read the status register, checking the DL_OK bit.
 - b. Read data and observe the status of the DL_OK bit.

Note that because the user coefficients are stored in RAM, they are cleared after a RESET operation or a loss of power.

Table 11. Filter Length Values

| FLEN[3:0] | Number of Coefficients | Filter Length |
|-----------|------------------------|---------------|
| 0000 | Default | Default |
| 0001 | 6 | 12 |
| 0011 | 12 | 24 |
| 0101 | 18 | 36 |
| 0111 | 24 | 48 |
| 1001 | 30 | 60 |
| 1011 | 36 | 72 |
| 1101 | 42 | 84 |
| 1111 | 48 | 96 |

EXAMPLE FILTER DOWNLOAD

The following is an example of downloading a short user-defined filter with 24 taps. The frequency response is shown in Figure 32.

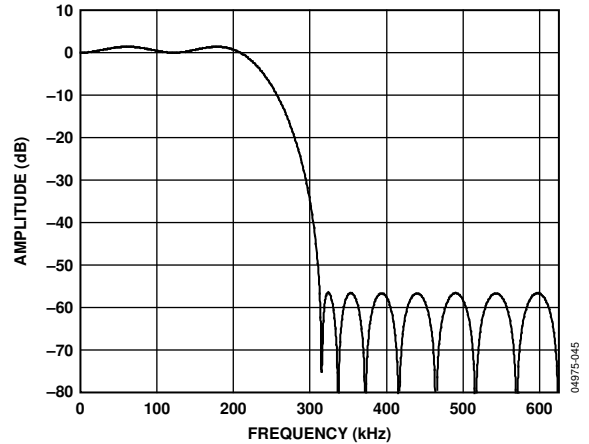

Figure 32. 24-Tap FIR Frequency Response

The coefficients for the filter are listed in Table 12 and are shown from the center of symmetry outwards. The raw coefficients were generated using a commercial filter design tool and scaled appropriately so their sum equals 67108863 (0x3FF FFFF).

Table 12. 24-Tap FIR Coefficients

| Coefficient | Raw | Scaled |
|-------------|--------------|-----------|
| 1 | 0.365481974 | 53188232 |
| 2 | 0.201339905 | 29300796 |
| 3 | 0.009636604 | 1402406 |
| 4 | -0.075708848 | -11017834 |
| 5 | -0.042856209 | -6236822 |
| 6 | 0.019944246 | 2902466 |
| 7 | 0.036437914 | 5302774 |
| 8 | 0.007592007 | 1104856 |
| 9 | -0.021556583 | -3137108 |
| 10 | -0.024888355 | -3621978 |
| 11 | -0.012379538 | -1801582 |
| 12 | -0.001905756 | -277343 |

Table 13 shows the hex values (in sign and magnitude format) that are downloaded to the [AD7762](#) to realize this filter. The table is also split into the bytes that are all summed to produce the checksum. The checksum generated from these coefficients is 0x0E6B.

Table 13. Filter Hex Values

| Coefficient | Word 1 | | Word 2 | |
|-------------|--------|--------|--------|--------|
| | Byte 1 | Byte 2 | Byte 3 | Byte 4 |
| 1 | 03 | 2B | 96 | 88 |
| 2 | 01 | BF | 18 | 3C |
| 3 | 00 | 15 | 66 | 26 |
| 4 | 04 | A8 | 1E | 6A |
| 5 | 04 | 5F | 2A | 96 |
| 6 | 00 | 2C | 49 | C2 |
| 7 | 00 | 50 | E9 | F6 |
| 8 | 00 | 10 | DB | D8 |
| 9 | 04 | 2F | DE | 54 |
| 10 | 04 | 37 | 44 | 5A |
| 11 | 04 | 1B | 7D | 6E |
| 12 | 04 | 04 | 3B | 5F |

Table 14 lists the 16-bit words the user would write to the [AD7762](#) to set up the ADC and download this filter, assuming an output data rate of 625 kHz has already been selected.

Table 14.

| Word | Description |
|--------|---|
| 0x0001 | Address of Control Register 1. |
| 0x8079 | Control register data. DL filter, set filter length = 24, set output data rate = 625 kHz. |
| 0x032B | First coefficient, Word 1. |
| 0x9688 | First coefficient, Word 2. |
| 0x01BF | Second coefficient, Word 1. |
| 0x183C | Second coefficient, Word 2. |
| ... | Other coefficients. |
| 0x0404 | Twelfth (final) coefficient, Word 1. |
| 0x3B5F | Final coefficient, Word 2. |
| 0x0E6B | Checksum. Wait $(0.5 \times t_{CLK} \times \text{Number of Unused Coefficients})$ for AD7762 to fill remaining unused coefficients with 0s. |
| 0x0001 | Address of control register. |
| 0x0879 | Control register data. Set read status and maintain filter length and decimation settings. Read contents of status register. Check Bit 7 (DL_OK) to determine that the filter was downloaded correctly. |

AD7762 REGISTERS

The AD7762 has a number of user-programmable registers. The control registers are used to set the decimation rate, the filter configuration, the clock divider, and so on. There are also digital gain, offset, and overrange threshold registers. Writing to these registers involves writing the register address first, then a 16-bit data-word. Register addresses, details of individual bits, and default values are given here.

CONTROL REGISTER 1—REG 0X0001

Default Value 0x001A

| MSB | | | | | | | | | | | LSB | | | | |
|---------|--------|---------|--------|---------|---|------|-------|-------|-------|-------|--------|---|------|------|------|
| DL_Filt | RD Ovr | RD Gain | RD Off | RD Stat | 0 | SYNC | FLEN3 | FLEN2 | FLEN1 | FLEN0 | BYP F3 | 1 | DEC2 | DEC1 | DEC0 |

Table 15.

| Bit | Mnemonic | Description |
|-----|------------------------|--|
| 15 | DL_Filt ¹ | Download Filter. Before downloading a user-defined filter, this bit must be set. The Filter Length bits must also be set at this time. The write operations that follow are interpreted as the user coefficients for the FIR filter until all the coefficients and the checksum have been written. |
| 14 | RD Ovr ^{1,2} | Read Overrange. If this bit has been set, the next read operation outputs the contents of the Overrange Threshold Register instead of a conversion result. |
| 13 | RD Gain ^{1,2} | Read Gain. If this bit has been set, the next read operation outputs the contents of the digital gain register. |
| 12 | RD Off ^{1,2} | Read Offset. If this bit has been set, the next read operation outputs the contents of the digital offset register. |
| 11 | RD Stat ^{1,2} | Read Status. If this bit has been set, the next read operation outputs the contents of the status register. |
| 10 | 0 | 0 must be written to this bit. |
| 9 | SYNC ¹ | Synchronize. Setting this bit initiates an internal synchronization routine. Setting this bit simultaneously on multiple devices synchronizes all filters. |
| 8-5 | FLEN3:0 | Filter Length Bits. These bits must be set when the DL Filt bit is set and before a user-defined filter is downloaded. |
| 4 | BYP F3 | Bypass Filter 3. If this bit is 0, Filter 3 (programmable FIR) is bypassed. |
| 3 | 1 | 1 must be written to this bit. |
| 2-0 | DEC2:0 | Decimation Rate. These bits set the decimation rate of Filter 2. All 0s implies that the filter is bypassed. A value of 1 corresponds to 2× decimation, a value of 2 corresponds to 4× decimation, and so on up to the maximum value of 5, corresponding to 32× decimation. |

¹ Bit 15 to Bit 9 are all self clearing bits.

² Only one of the bits from Bit 14 to Bit 11 can be set in any write operation because it determines the contents of the next read operation.

CONTROL REGISTER 2—ADDRESS 0X0002

Default Value 0x009B

| MSB | | | | | | | | | | | LSB | | | | | |
|-----|---|---|---|---|---|---|---|---|---|---|------|---|----|------|---|------|
| 0 | 0 | 0 | 0 | 0 | 0 | 0 | 0 | 0 | 0 | 0 | CDIV | 0 | PD | LPWR | 1 | D1PD |

Table 16.

| Bit | Mnemonic | Description |
|-----|----------|---|
| 5 | CDIV | Clock Divider Bit. This sets the divide ratio of the MCLK signal to produce the internal ICLK. Setting CDIV = 0 divides the MCLK by 2. If CDIV = 1, then the ICLK frequency is equal to the MCLK. |
| 3 | PD | Power Down. Setting this bit powers down the AD7762, reducing the power consumption to 6.35 mW. |
| 2 | LPWR | Low Power. If this bit is set, the AD7762 is operating in a low power mode. The power consumption is reduced for a 6 dB reduction in noise performance. |
| 1 | 1 | Write 1 to this bit. |
| 0 | D1PD | Differential Amplifier Power Down. Setting this bit powers down the on-chip differential amplifier. |

STATUS REGISTER (READ ONLY)

| MSB | | | | | | | | | | | LSB | | | | |
|--------|--------|-------|-------|-------|--------|------|-----|-------|-----------|----------|--------|---|------|------|------|
| PART 1 | PART 0 | DIE 2 | DIE 1 | DIE 0 | DVALID | LPWR | OVR | DL OK | Filter OK | U Filter | BYP F3 | 1 | DEC2 | DEC1 | DEC0 |

Table 17.

| Bit | Mnemonic | Comment |
|----------|-----------|--|
| 15, 14 | PART1:0 | Part Number. These bits are constant for the AD7762 . |
| 13 to 11 | DIE2:0 | Die Number. These bits reflect the current AD7762 die number for identification purposes within a system. |
| 10 | DVALID | Data Valid. This bit corresponds to the DVALID bit in the status word output in the second 16-bit read operation. |
| 9 | LPWR | Low Power. If the AD7762 is operating in low power mode, this bit is set to 1. |
| 8 | OVR | If the current analog input exceeds the current overrange threshold, this bit is set. |
| 7 | DL OK | When downloading a user filter to the AD7762 , a checksum is generated. This checksum is compared to the one downloaded following the coefficients. If these checksums agree, this bit is set. |
| 6 | Filter OK | When a user-defined filter is in use, a checksum is generated when the filter coefficients pass through the filter. This generated checksum is compared to the one downloaded. If they match, this bit is set. |
| 5 | U Filter | If a user-defined filter is in use, this bit is set. |
| 4 | BYP F3 | Bypass Filter 3. If Filter 3 is bypassed by setting the relevant bit in Control Register 1, this bit is also set. |
| 3 | 1 | This bit is always set. |
| 2-0 | DEC2:0 | Decimation Rate. These correspond to the bits set in Control Register 1. |

OFFSET REGISTER—ADDRESS 0X0003***Non-bitmapped, Default Value 0x0000***

The offset register uses twos complement notation and is scaled such that 0x7FFF (maximum positive value) and 0x8000 (maximum negative value) correspond to an offset of +0.78125% and -0.78125%, respectively. Offset correction is applied after any gain correction. Using the default gain value of 1.25 and assuming a reference voltage of 4.096 V, the offset correction range is approximately ± 25 mV.

GAIN REGISTER—ADDRESS 0X0004***Non-bitmapped, Default Value 0xA000***

The gain register is scaled such that 0x8000 corresponds to a gain of 1.0. The default value of this register is 1.25 (0xA000). This gives a full-scale digital output when the input is at 80% of V_{REF} . This ties in with the maximum analog input range of $\pm 80\%$ of V_{REF} p-p.

OVERRANGE REGISTER—ADDRESS 0X0005***Non-bitmapped, Default Value 0xCCCC***

The overrange register value is compared with the output of the first decimation filter to obtain an overload indication with minimum propagation delay. This is prior to any gain scaling or offset adjustment. The default value is 0xCCCC which corresponds to 80% of V_{REF} (the maximum permitted analog input voltage). Assuming $V_{REF} = 4.096$ V, the bit is then set when the input voltage exceeds approximately 6.55 V p-p differential. Note that the overrange bit is also set immediately if the analog input voltage exceeds 100% of V_{REF} for more than four consecutive samples at the modulator rate.