



Chipsmall Limited consists of a professional team with an average of over 10 year of expertise in the distribution of electronic components. Based in Hongkong, we have already established firm and mutual-benefit business relationships with customers from,Europe,America and south Asia,supplying obsolete and hard-to-find components to meet their specific needs.

With the principle of “Quality Parts,Customers Priority,Honest Operation,and Considerate Service”,our business mainly focus on the distribution of electronic components. Line cards we deal with include Microchip,ALPS,ROHM,Xilinx,Pulse,ON,Everlight and Freescale. Main products comprise IC,Modules,Potentiometer,IC Socket,Relay,Connector.Our parts cover such applications as commercial,industrial, and automotives areas.

We are looking forward to setting up business relationship with you and hope to provide you with the best service and solution. Let us make a better world for our industry!



Contact us

Tel: +86-755-8981 8866 Fax: +86-755-8427 6832

Email & Skype: info@chipsmall.com Web: www.chipsmall.com

Address: A1208, Overseas Decoration Building, #122 Zhenhua RD., Futian, Shenzhen, China



Evaluating the **AD8244** Quad FET Input Buffer

FEATURES

Enables quick evaluation of the **AD8244**

Enables quick prototyping

Allows for various circuit configurations

SMA/SMB or test loop inputs and outputs

Easy connection to test equipment and other circuits

RoHS compliant

GENERAL DESCRIPTION

The **AD8244-EVALZ** makes it easy for designers to obtain quick performance results for their particular application circuit using the **AD8244** quad, FET input, unity-gain buffer.

The evaluation board design is flexible to allow for common circuit options, including source impedance and space for output loading and filtering. Most resistors and capacitors use 0805 packages.

This 4-layer evaluation board comes installed with color-coded test loops, mainly intended for use with mini-clip type connectors. The board also has pads for end-launch SMA or SMB connectors on inputs and outputs, recommended for tests that require higher signal integrity than the mini-clip can provide. The inputs are guarded to avoid leakage and maximize the input impedance. The ground plane, component placement, and power supply bypassing have been optimized for maximum circuit flexibility and performance.

Figure 1 shows the primary side of the evaluation board. Figure 2 shows the evaluation board schematic.

The evaluation board accommodates the **AD8244** quad FET-input buffer in a 10-lead MSOP. The **AD8244** data sheet should be consulted in conjunction with this evaluation board user guide.

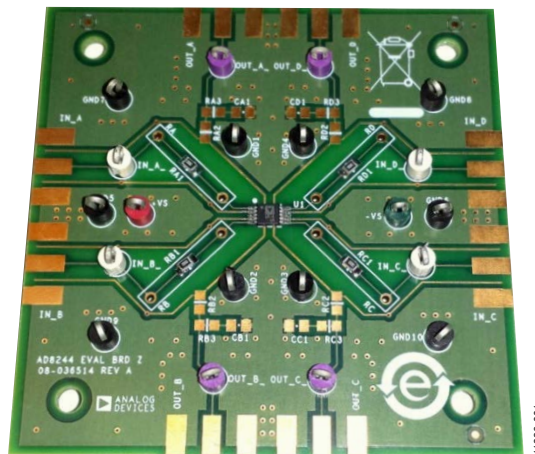

Figure 1. **AD8244-EVALZ** Primary Side

TABLE OF CONTENTS

Features	1	SMA Input/Output Connectors	3
General Description	1	Guarding.....	3
Revision History	2	Schematic.....	4
Evaluation Board Hardware.....	3	Ordering Information.....	5
Power Supplies	3	Bill of Materials.....	5
Board Options.....	3	Related Links.....	5

REVISION HISTORY

12/13—Revision 0: Initial Version

EVALUATION BOARD HARDWARE

POWER SUPPLIES

Power is applied to the board through test points +VS and –VS (see Figure 2). The board accommodates single or dual supplies. For single-supply operation, connect the negative supply to ground.

It is very important that the power supply pins of the [AD8244](#) have decoupling circuitry. The board layout facilitates this with 0.1 μ F, 0805 ceramic capacitors (C3 and C4) on each supply. Lower frequency decoupling is provided by C1 and C2, which are D-size, 10 μ F tantalum capacitors.

BOARD OPTIONS

The [AD8244-EVALZ](#) board comes installed with the default components listed in Table 1. The default configuration has no added source impedance or output load. In addition to the default, the board is easily configurable to test the [AD8244](#) with source impedance and load impedance.

The user may remove the zero Ω resistor in series with the [AD8244](#) input and install SMD or through-hole components to represent the source impedance.

The user may load the [AD8244](#) with resistance or capacitance using 0805 components at RX2 (which refers to RA2, RB2, RC2, and RD2 depending upon whether it is in channel A, B, C, or

D), RX3, and CX1. RX2 is in series with the outputs. RX3 and CX1 may be used to form a snubber, which is an RC network placed between the output of an amplifier and ground to improve step response and stability with capacitive loads.

Before installing any components at RX2 or at RX3, be sure to cut the short between the pads with a box cutter or similar tool.

SMA INPUT/OUTPUT CONNECTORS

The inputs and outputs of every channel have end-launch SMA connector footprints (which are also compatible with some SMB connector footprints) for convenient connection to coaxial cables. The recommended connectors are Johnson/Emerson 142-0701-851 (SMA jack), 142-0801-811 (SMA plug), 131-3701-801 (SMB jack), or equivalent footprint connectors.

GUARDING

The inputs of each channel of the [AD8244](#) are guarded to reduce leakage and parasitic capacitance at the inputs. In order for the guard to be effective against leakage contamination on the surface of the board, the solder mask is removed from the top of the guard traces. During rework, take care that the guard does not accidentally become shorted to a nearby node. See the [AD8244](#) data sheet for more information about guarding.

SCHEMATIC

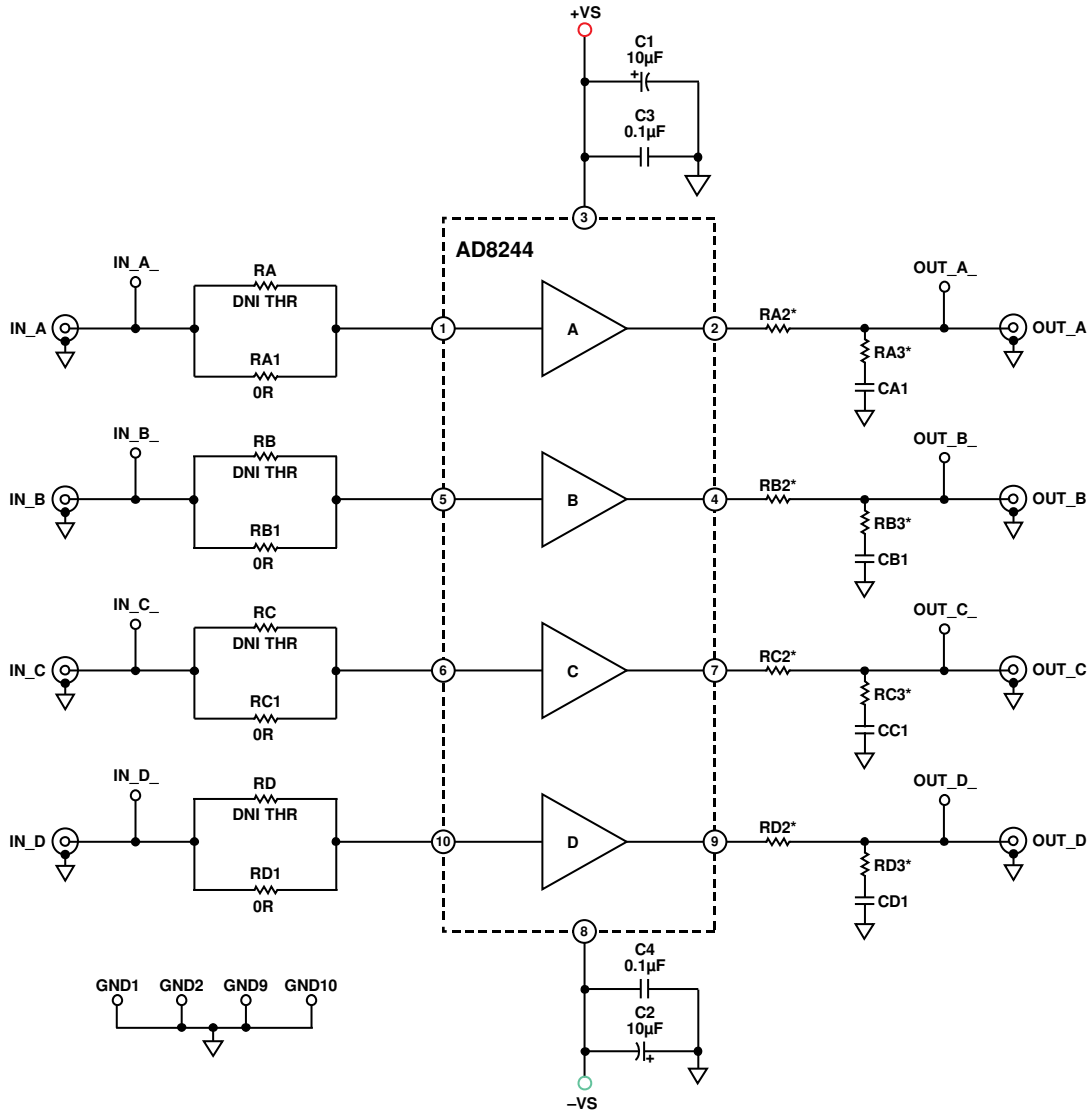

*THIS COMPONENT IS PRESHORTED. THE SHORT MUST BE CUT BEFORE INSTALLING A COMPONENT IN THIS LOCATION.

Figure 2. AD8244-EVALZ Schematic

11986-002

ORDERING INFORMATION

BILL OF MATERIALS

Table 1.

Qty	Reference Designator	Package	Description	Default
2	C1, C2	C7343	10 μ F capacitor, tantalum	Yes
2	C3, C4	C0805	Capacitor, 0.1 μ F, X7R	Yes
8	IN_A, IN_B, IN_C, IN_D, OUT_A, OUT_B, OUT_C, OUT_D	SMA/SMB PCM	SMA/SMB connector	No
4	RA1, RB1, RC1, RD1	R0805	Resistor, 0 Ω	Yes
8	RA2, RB2, RC2, RD2, RA3, RB3, RC3, RD3	R0805	Resistor, user defined value (pre-shortcd)	No
4	CA1, CB1, CC1, CD1	C0805	Capacitor, user defined value	No
20	+VS, -VS, IN_A_, IN_B_, IN_C_, IN_D_, OUT_A_, OUT_B_, OUT_C_, OUT_D_, GND1 to GND10	TP1	Test point	Yes
1	U1	10-lead MSOP	AD8244 ARMZ quad JFET-input buffer IC	Yes
1	—		PC board	N/A

RELATED LINKS

Table 2.

Resource	Description
AD8244	Product page; single supply, low power, precision FET input quad buffer

NOTES

NOTES

NOTES

**ESD Caution**

ESD (electrostatic discharge) sensitive device. Charged devices and circuit boards can discharge without detection. Although this product features patented or proprietary protection circuitry, damage may occur on devices subjected to high energy ESD. Therefore, proper ESD precautions should be taken to avoid performance degradation or loss of functionality.

Legal Terms and Conditions

By using the evaluation board discussed herein (together with any tools, components documentation or support materials, the "Evaluation Board"), you are agreeing to be bound by the terms and conditions set forth below ("Agreement") unless you have purchased the Evaluation Board, in which case the Analog Devices Standard Terms and Conditions of Sale shall govern. Do not use the Evaluation Board until you have read and agreed to the Agreement. Your use of the Evaluation Board shall signify your acceptance of the Agreement. This Agreement is made by and between you ("Customer") and Analog Devices, Inc. ("ADI"), with its principal place of business at One Technology Way, Norwood, MA 02062, USA. Subject to the terms and conditions of the Agreement, ADI hereby grants to Customer a free, limited, personal, temporary, non-exclusive, non-sublicensable, non-transferable license to use the Evaluation Board FOR EVALUATION PURPOSES ONLY. Customer understands and agrees that the Evaluation Board is provided for the sole and exclusive purpose referenced above, and agrees not to use the Evaluation Board for any other purpose. Furthermore, the license granted is expressly made subject to the following additional limitations: Customer shall not (i) rent, lease, display, sell, transfer, assign, sublicense, or distribute the Evaluation Board; and (ii) permit any Third Party to access the Evaluation Board. As used herein, the term "Third Party" includes any entity other than ADI, Customer, their employees, affiliates and in-house consultants. The Evaluation Board is NOT sold to Customer; all rights not expressly granted herein, including ownership of the Evaluation Board, are reserved by ADI. CONFIDENTIALITY. This Agreement and the Evaluation Board shall all be considered the confidential and proprietary information of ADI. Customer may not disclose or transfer any portion of the Evaluation Board to any other party for any reason. Upon discontinuation of use of the Evaluation Board or termination of this Agreement, Customer agrees to promptly return the Evaluation Board to ADI. ADDITIONAL RESTRICTIONS. Customer may not disassemble, decompile or reverse engineer chips on the Evaluation Board. Customer shall inform ADI of any occurred damages or any modifications or alterations it makes to the Evaluation Board, including but not limited to soldering or any other activity that affects the material content of the Evaluation Board. Modifications to the Evaluation Board must comply with applicable law, including but not limited to the RoHS Directive. TERMINATION. ADI may terminate this Agreement at any time upon giving written notice to Customer. Customer agrees to return to ADI the Evaluation Board at that time. LIMITATION OF LIABILITY. THE EVALUATION BOARD PROVIDED HEREUNDER IS PROVIDED "AS IS" AND ADI MAKES NO WARRANTIES OR REPRESENTATIONS OF ANY KIND WITH RESPECT TO IT. ADI SPECIFICALLY DISCLAIMS ANY REPRESENTATIONS, ENDORSEMENTS, GUARANTEES, OR WARRANTIES, EXPRESS OR IMPLIED, RELATED TO THE EVALUATION BOARD INCLUDING, BUT NOT LIMITED TO, THE IMPLIED WARRANTY OF MERCHANTABILITY, TITLE, FITNESS FOR A PARTICULAR PURPOSE OR NON-INFRINGEMENT OF INTELLECTUAL PROPERTY RIGHTS. IN NO EVENT WILL ADI AND ITS LICENSORS BE LIABLE FOR ANY INCIDENTAL, SPECIAL, INDIRECT, OR CONSEQUENTIAL DAMAGES RESULTING FROM CUSTOMER'S POSSESSION OR USE OF THE EVALUATION BOARD, INCLUDING BUT NOT LIMITED TO LOST PROFITS, DELAY COSTS, LABOR COSTS OR LOSS OF GOODWILL. ADI'S TOTAL LIABILITY FROM ANY AND ALL CAUSES SHALL BE LIMITED TO THE AMOUNT OF ONE HUNDRED US DOLLARS (\$100.00). EXPORT. Customer agrees that it will not directly or indirectly export the Evaluation Board to another country, and that it will comply with all applicable United States federal laws and regulations relating to exports. GOVERNING LAW. This Agreement shall be governed by and construed in accordance with the substantive laws of the Commonwealth of Massachusetts (excluding conflict of law rules). Any legal action regarding this Agreement will be heard in the state or federal courts having jurisdiction in Suffolk County, Massachusetts, and Customer hereby submits to the personal jurisdiction and venue of such courts. The United Nations Convention on Contracts for the International Sale of Goods shall not apply to this Agreement and is expressly disclaimed.