



Chipsmall Limited consists of a professional team with an average of over 10 year of expertise in the distribution of electronic components. Based in Hongkong, we have already established firm and mutual-benefit business relationships with customers from,Europe,America and south Asia,supplying obsolete and hard-to-find components to meet their specific needs.

With the principle of “Quality Parts,Customers Priority,Honest Operation,and Considerate Service”,our business mainly focus on the distribution of electronic components. Line cards we deal with include Microchip,ALPS,ROHM,Xilinx,Pulse,ON,Everlight and Freescale. Main products comprise IC,Modules,Potentiometer,IC Socket,Relay,Connector.Our parts cover such applications as commercial,industrial, and automotives areas.

We are looking forward to setting up business relationship with you and hope to provide you with the best service and solution. Let us make a better world for our industry!



## Contact us

Tel: +86-755-8981 8866 Fax: +86-755-8427 6832

Email & Skype: info@chipsmall.com Web: www.chipsmall.com

Address: A1208, Overseas Decoration Building, #122 Zhenhua RD., Futian, Shenzhen, China



## FEATURES

1.8 V analog supply operation

1.8 V to 3.3 V output supply

SNR

61.5 dBFS at 9.7 MHz input

61.0 dBFS at 200 MHz input

SFDR

75 dBc at 9.7 MHz input

73 dBc at 200 MHz input

Low power

45 mW at 20 MSPS

76 mW at 80 MSPS

Differential input with 700 MHz bandwidth

On-chip voltage reference and sample-and-hold circuit

2 V p-p differential analog input

DNL =  $\pm 0.10$  LSB

Serial port control options

Offset binary, gray code, or twos complement data format

Optional clock duty cycle stabilizer

Integer 1-to-8 input clock divider

Built-in selectable digital test pattern generation

Energy-saving power-down modes

Data clock out with programmable clock and data alignment

## APPLICATIONS

Communications

Diversity radio systems

Multimode digital receivers

GSM, EDGE, W-CDMA, LTE, CDMA2000, WiMAX, TD-SCDMA

Smart antenna systems

Battery-powered instruments

Handheld scope meters

Portable medical imaging

Ultrasound

Radar/LIDAR

PET/SPECT imaging

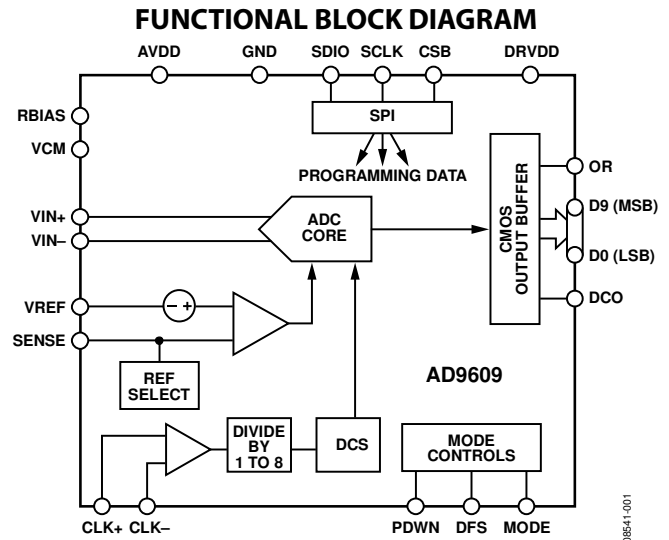

Figure 1.

## PRODUCT HIGHLIGHTS

1. The **AD9609** operates from a single 1.8 V analog power supply and features a separate digital output driver supply to accommodate 1.8 V to 3.3 V logic families.
2. The sample-and-hold circuit maintains excellent performance for input frequencies up to 200 MHz and is designed for low cost, low power, and ease of use.
3. A standard serial port interface supports various product features and functions, such as data output formatting, internal clock divider, power-down, DCO and data output (D9 to D0) timing and offset adjustments, and voltage reference modes.
4. The **AD9609** is packaged in a 32-lead RoHS compliant LFCSP that is pin compatible with the **AD9629** 12-bit ADC and the **AD9649** 14-bit ADC, enabling a simple migration path between 10-bit and 14-bit converters sampling from 20 MSPS to 80 MSPS.

Rev. B

[Document Feedback](#)

Information furnished by Analog Devices is believed to be accurate and reliable. However, no responsibility is assumed by Analog Devices for its use, nor for any infringements of patents or other rights of third parties that may result from its use. Specifications subject to change without notice. No license is granted by implication or otherwise under any patent or patent rights of Analog Devices. Trademarks and registered trademarks are the property of their respective owners.

# AD9609\* PRODUCT PAGE QUICK LINKS

Last Content Update: 02/23/2017

---

## COMPARABLE PARTS

View a parametric search of comparable parts.

## EVALUATION KITS

- AD9609 Evaluation Board

## DOCUMENTATION

### Application Notes

- AN-1142: Techniques for High Speed ADC PCB Layout
- AN-586: LVDS Outputs for High Speed A/D Converters
- AN-742: Frequency Domain Response of Switched-Capacitor ADCs
- AN-807: Multicarrier WCDMA Feasibility
- AN-808: Multicarrier CDMA2000 Feasibility
- AN-812: MicroController-Based Serial Port Interface (SPI) Boot Circuit
- AN-827: A Resonant Approach to Interfacing Amplifiers to Switched-Capacitor ADCs
- AN-878: High Speed ADC SPI Control Software
- AN-935: Designing an ADC Transformer-Coupled Front End

### Data Sheet

- AD9609: 10-Bit, 20 MSPS/40 MSPS/65 MSPS/80 MSPS, 1.8 V Analog-to-Digital Converter Data Sheet

### User Guides

- Evaluating the AD9266/AD9649/AD9629/AD9609 Analog-to-Digital Converters

## TOOLS AND SIMULATIONS

- Visual Analog
- AD9609 IBIS Model

## REFERENCE MATERIALS

### Technical Articles

- Improve The Design Of Your Passive Wideband ADC Front-End Network
- MS-2210: Designing Power Supplies for High Speed ADC

## DESIGN RESOURCES

- AD9609 Material Declaration
- PCN-PDN Information
- Quality And Reliability
- Symbols and Footprints

## DISCUSSIONS

View all AD9609 EngineerZone Discussions.

## SAMPLE AND BUY

Visit the product page to see pricing options.

## TECHNICAL SUPPORT

Submit a technical question or find your regional support number.

## DOCUMENT FEEDBACK

Submit feedback for this data sheet.

---



## TABLE OF CONTENTS

|   |    |   |    |
|---|----|---|----|
| Features .....                                    | 1  | Voltage Reference .....                         | 19 |
| Applications .....                                | 1  | Clock Input Considerations .....                | 20 |
| Functional Block Diagram .....                    | 1  | Power Dissipation and Standby Mode .....        | 22 |
| Product Highlights .....                          | 1  | Digital Outputs .....                           | 22 |
| Revision History .....                            | 2  | Timing .....                                    | 23 |
| General Description .....                         | 3  | Built-In Self-Test (BIST) and Output Test ..... | 24 |
| Specifications .....                              | 4  | Built-In Self-Test (BIST) .....                 | 24 |
| DC Specifications .....                           | 4  | Output Test Modes .....                         | 24 |
| AC Specifications .....                           | 5  | Serial Port Interface (SPI) .....               | 25 |
| Digital Specifications .....                      | 6  | Configuration Using the SPI .....               | 25 |
| Switching Specifications .....                    | 7  | Hardware Interface .....                        | 26 |
| Timing Specifications .....                       | 8  | Configuration Without the SPI .....             | 26 |
| Absolute Maximum Ratings .....                    | 9  | SPI Accessible Features .....                   | 26 |
| Thermal Characteristics .....                     | 9  | Memory Map .....                                | 27 |
| ESD Caution .....                                 | 9  | Reading the Memory Map Register Table .....     | 27 |
| Pin Configuration and Function Descriptions ..... | 10 | Open Locations .....                            | 27 |
| Typical Performance Characteristics .....         | 11 | Default Values .....                            | 27 |
| AD9609-80 .....                                   | 11 | Memory Map Register Table .....                 | 28 |
| AD9609-65 .....                                   | 13 | Memory Map Register Descriptions .....          | 30 |
| AD9609-40 .....                                   | 14 | Applications Information .....                  | 31 |
| AD9609-20 .....                                   | 15 | Design Guidelines .....                         | 31 |
| Equivalent Circuits .....                         | 16 | Outline Dimensions .....                        | 32 |
| Theory of Operation .....                         | 17 | Ordering Guide .....                            | 32 |
| Analog Input Considerations .....                 | 17 |   |    |

## REVISION HISTORY

### 2/2017—Rev. A to Rev. B

|   |    |
|---|----|
| Added Endnote 1, Table 17 .....                           | 28 |
| Changes to Power and Ground Recommendations Section ..... | 31 |
| Added Soft Reset Section .....                            | 31 |

### 6/2015—Rev. 0 to Rev. A

|  |    |
|--|----|
| Change to Product Highlights Section ..... | 1  |
| Changes to Figure 3 and Table 8 .....      | 10 |
| Updated Outline Dimensions .....           | 32 |
| Changes to Ordering Guide .....            | 32 |

### 10/2009—Revision 0: Initial Version

## GENERAL DESCRIPTION

The [AD9609](#) is a monolithic, single channel 1.8 V supply, 10-bit, 20/40/65/80 MSPS analog-to-digital converter (ADC). It features a high performance sample-and-hold circuit and on-chip voltage reference.

The product uses multistage differential pipeline architecture with output error correction logic to provide 10-bit accuracy at 80 MSPS data rates and to guarantee no missing codes over the full operating temperature range.

The ADC contains several features designed to maximize flexibility and minimize system cost, such as programmable clock and data alignment and programmable digital test pattern generation. The available digital test patterns include built-in deterministic and pseudorandom patterns, along with custom user-defined test patterns entered via the serial port interface (SPI).

A differential clock input with selectable internal 1 to 8 divide ratio controls all internal conversion cycles. An optional duty cycle stabilizer (DCS) compensates for wide variations in the clock duty cycle while maintaining excellent overall ADC performance.

The digital output data is presented in offset binary, gray code, or twos complement format. A data output clock (DCO) is provided to ensure proper latch timing with receiving logic. Both 1.8 V and 3.3 V CMOS levels are supported.

The [AD9609](#) is available in a 32-lead RoHS-compliant LFCSP and is specified over the industrial temperature range ( $-40^{\circ}\text{C}$  to  $+85^{\circ}\text{C}$ ).

## SPECIFICATIONS

### DC SPECIFICATIONS

AVDD = 1.8 V; DRVDD = 1.8 V, maximum sample rate, 2 V p-p differential input, 1.0 V internal reference; AIN = -1.0 dBFS, 50% duty cycle clock, DCS disabled, unless otherwise noted.

Table 1.

| Parameter                                    | Temp | AD9609-20/AD9609-40 |       |       | AD9609-65  |       |       | AD9609-80  |       |       | Unit    |      |    |    |
|--|------|---------------------|-------|-------|------------|-------|-------|------------|-------|-------|---------|------|----|----|
|  |      | Min                 | Typ   | Max   | Min        | Typ   | Max   | Min        | Typ   | Max   |         |      |    |    |
| RESOLUTION                                   | Full | 10                  |       |       | 10         |       |       | 10         |       |       | Bits    |      |    |    |
| ACCURACY                                     |      |                     |       |       |            |       |       |            |       |       |         |      |    |    |
| No Missing Codes                             | Full | Guaranteed          |       |       | Guaranteed |       |       | Guaranteed |       |       |         |      |    |    |
| Offset Error                                 | Full | -0.45               | +0.05 | +0.55 | -0.45      | +0.05 | +0.55 | -0.45      | +0.05 | +0.55 | % FSR   |      |    |    |
| Gain Error <sup>1</sup>                      | Full | -1.5                |       |       | -1.5       |       |       | -1.5       |       |       | % FSR   |      |    |    |
| Differential Nonlinearity (DNL) <sup>2</sup> | Full | ±0.15/±0.25         |       |       | ±0.25      |       |       | ±0.25      |       |       | LSB     |      |    |    |
|  | 25°C | ±0.05/±0.08         |       |       | ±0.15      |       |       | ±0.07      |       |       | LSB     |      |    |    |
| Integral Nonlinearity (INL) <sup>2</sup>     | Full | ±0.35               |       |       | ±0.45      |       |       | ±0.45      |       |       | LSB     |      |    |    |
|  | 25°C | ±0.15               |       |       | ±0.15      |       |       | ±0.15      |       |       | LSB     |      |    |    |
| TEMPERATURE DRIFT                            |      |                     |       |       |            |       |       |            |       |       |         |      |    |    |
| Offset Error                                 | Full | ±2                  |       |       | ±2         |       |       | ±2         |       |       | ppm/°C  |      |    |    |
| INTERNAL VOLTAGE REFERENCE                   |      |                     |       |       |            |       |       |            |       |       |         |      |    |    |
| Output Voltage (1 V Mode)                    | Full | 0.984               | 0.996 | 1.008 | 0.984      | 0.996 | 1.008 | 0.984      | 0.996 | 1.008 | V       |      |    |    |
| Load Regulation Error at 1.0 mA              | Full | 2                   |       |       | 2          |       |       | 2          |       |       | mV      |      |    |    |
| INPUT-REFERRED NOISE                         |      |                     |       |       |            |       |       |            |       |       |         |      |    |    |
| VREF = 1.0 V                                 | 25°C | 0.06                |       |       | 0.08       |       |       | 0.08       |       |       | LSB rms |      |    |    |
| ANALOG INPUT                                 |      |                     |       |       |            |       |       |            |       |       |         |      |    |    |
| Input Span, VREF = 1.0 V                     | Full | 2                   |       |       | 2          |       |       | 2          |       |       | V p-p   |      |    |    |
| Input Capacitance <sup>3</sup>               | Full | 6                   |       |       | 6          |       |       | 6          |       |       | pF      |      |    |    |
| Input Common-Mode Voltage                    | Full | 0.9                 |       |       | 0.9        |       |       | 0.9        |       |       | V       |      |    |    |
| Input Common-Mode Range                      | Full | 0.5                 |       | 1.3   | 0.5        |       | 1.3   | 0.5        |       | 1.3   | V       |      |    |    |
| REFERENCE INPUT RESISTANCE                   | Full | 7.5                 |       |       | 7.5        |       |       | 7.5        |       |       | kΩ      |      |    |    |
| POWER SUPPLIES                               |      |                     |       |       |            |       |       |            |       |       |         |      |    |    |
| Supply Voltage                               |      |                     |       |       |            |       |       |            |       |       |         |      |    |    |
| AVDD   | Full | 1.7                 | 1.8   | 1.9   | 1.7        | 1.8   | 1.9   | 1.7        | 1.8   | 1.9   | V       |      |    |    |
| DRVDD  | Full | 1.7                 |       | 3.6   | 1.7        |       | 3.6   | 1.7        |       | 3.6   | V       |      |    |    |
| Supply Current                               |      |                     |       |       |            |       |       |            |       |       |         |      |    |    |
| I <sub>AVDD</sub> <sup>2</sup>               | Full | 24.9/29.7           |       |       | 27.0/32.0  |       |       | 37.1       |       |       | 39.5    | 41.8 | 45 | mA |
| I <sub>DRVDD</sub> <sup>2</sup> (1.8 V)      | Full | 1.4/2.2             |       |       | 3.6        |       |       | 4.3        |       |       |         |      | mA |    |
| I <sub>DRVDD</sub> <sup>2</sup> (3.3 V)      | Full | 2.5/4.1             |       |       | 6.6        |       |       | 7.9        |       |       |         |      | mA |    |
| POWER CONSUMPTION                            |      |                     |       |       |            |       |       |            |       |       |         |      |    |    |
| DC Input                                     | Full | 45.2/54.7           |       |       | 67.7       |       |       | 76.3       |       |       |         | mW   |    |    |
| Sine Wave Input <sup>2</sup> (DRVDD = 1.8 V) | Full | 46.3/57.4           |       |       | 52.0/61.0  |       |       | 73.3       |       |       | 78.0    | 83.0 | 92 | mW |
| Sine Wave Input <sup>2</sup> (DRVDD = 3.3 V) | Full | 53.1/67.0           |       |       | 88.6       |       |       | 89.5       |       |       |         |      | mW |    |
| Standby Power <sup>4</sup>                   | Full | 34                  |       |       | 34         |       |       | 34         |       |       |         |      | mW |    |
| Power-Down Power                             | Full | 0.5                 |       |       | 0.5        |       |       | 0.5        |       |       |         |      | mW |    |

<sup>1</sup> Measured with 1.0 V external reference.

<sup>2</sup> Measured with a 10 MHz input frequency at rated sample rate, full-scale sine wave, with approximately 5 pF loading on each output bit.

<sup>3</sup> Input capacitance refers to the effective capacitance between one differential input pin and AGND.

<sup>4</sup> Standby power is measured with a dc input and the CLK active.

## AC SPECIFICATIONS

AVDD = 1.8 V; DRVDD = 1.8 V, maximum sample rate, 2 V p-p differential input, 1.0 V internal reference; AIN = -1.0 dBFS, 50% duty cycle clock, DCS disabled, unless otherwise noted.

Table 2.

| Parameter <sup>1</sup>                            | Temp                | AD9609-20/AD9609-40 |           |      | AD9609-65 |      |      | AD9609-80 |      |      | Unit |
|---|---------------------|---------------------|-----------|------|-----------|------|------|-----------|------|------|------|
|   |                     | Min                 | Typ       | Max  | Min       | Typ  | Max  | Min       | Typ  | Max  |      |
| SIGNAL-TO-NOISE RATIO (SNR)                       | $f_{IN} = 9.7$ MHz  |                     | 61.7      |      |           | 61.5 |      |           | 61.5 |      | dBFS |
|   | $f_{IN} = 30.5$ MHz |                     | 61.7      |      |           | 61.5 |      |           | 61.5 |      | dBFS |
|   |                     | Full                | 61.2      |      |           | 61.0 |      |           |      |      | dBFS |
|   | $f_{IN} = 70$ MHz   | 25°C                |           | 61.6 |           |      | 61.5 |           |      | 61.5 | dBFS |
|   |                     | Full                |           |      |           |      |      |           | 61.0 |      | dBFS |
| $f_{IN} = 200$ MHz                                | 25°C                |                     |           |      |           | 61.0 |      |           | 61.0 | dBFS |      |
| SIGNAL-TO-NOISE-AND-DISTORTION (SINAD)            | $f_{IN} = 9.7$ MHz  |                     | 61.6      |      |           | 61.4 |      |           | 61.4 |      | dBFS |
|   | $f_{IN} = 30.5$ MHz |                     | 61.5      |      |           | 61.3 |      |           | 61.4 |      | dBFS |
|   |                     | Full                | 60.7/60.9 |      |           | 60.5 |      |           |      |      | dBFS |
|   | $f_{IN} = 70$ MHz   | 25°C                |           | 61.5 |           |      | 61.4 |           |      | 61.4 | dBFS |
|   |                     | Full                |           |      |           |      |      |           | 60.5 |      | dBFS |
| $f_{IN} = 200$ MHz                                | 25°C                |                     |           |      |           | 60   |      |           | 60   | dBFS |      |
| EFFECTIVE NUMBER OF BITS (ENOB)                   | $f_{IN} = 9.7$ MHz  |                     | 9.9       |      |           | 9.9  |      |           | 9.9  |      | Bits |
|   | $f_{IN} = 30.5$ MHz |                     | 9.9       |      |           | 9.9  |      |           | 9.9  |      | Bits |
|   | $f_{IN} = 70$ MHz   |                     | 9.9       |      |           | 9.9  |      |           | 9.9  |      | Bits |
|   |                     | 25°C                |           |      |           |      |      |           |      |      | Bits |
|   | $f_{IN} = 200$ MHz  | 25°C                |           |      |           |      | 9.6  |           |      | 9.6  | Bits |
| WORST SECOND OR THIRD HARMONIC                    | $f_{IN} = 9.7$ MHz  |                     | -81       |      |           | -78  |      |           | -78  |      | dBc  |
|   | $f_{IN} = 30.5$ MHz |                     | -80       |      |           | -80  |      |           | -80  |      | dBc  |
|   |                     | Full                |           |      | -67       |      |      | -65.5     |      |      | dBc  |
|   | $f_{IN} = 70$ MHz   | 25°C                |           | -82  |           |      | -78  |           |      | -78  | dBc  |
|   |                     | Full                |           |      |           |      |      |           |      | -68  | dBc  |
| $f_{IN} = 200$ MHz                                | 25°C                |                     |           |      |           | -73  |      |           | -73  | dBc  |      |
| SPURIOUS-FREE DYNAMIC RANGE (SFDR)                | $f_{IN} = 9.7$ MHz  |                     | 78        |      |           | 75   |      |           | 75   |      | dBc  |
|   | $f_{IN} = 30.5$ MHz |                     | 80.5      |      |           | 75   |      |           | 75   |      | dBc  |
|   |                     | Full                | 67        |      |           | 65.5 |      |           |      |      | dBc  |
|   | $f_{IN} = 70$ MHz   | 25°C                |           | 78   |           |      | 75   |           |      | 75   | dBc  |
|   |                     | Full                |           |      |           |      |      |           | 68   |      | dBc  |
| $f_{IN} = 200$ MHz                                | 25°C                |                     |           |      |           | 73   |      |           | 73   | dBc  |      |
| WORST OTHER (HARMONIC OR SPUR)                    | $f_{IN} = 9.7$ MHz  |                     | -82       |      |           | -80  |      |           | -80  |      | dBc  |
|   | $f_{IN} = 30.5$ MHz |                     | -82       |      |           | -80  |      |           | -80  |      | dBc  |
|   |                     | Full                |           |      | -74       |      |      | -72       |      |      | dBc  |
|   | $f_{IN} = 70$ MHz   | 25°C                |           | -82  |           |      | -80  |           |      | -80  | dBc  |
|   |                     | Full                |           |      |           |      |      |           |      | -73  | dBc  |
| $f_{IN} = 200$ MHz                                | 25°C                |                     |           |      |           | -80  |      |           | -80  | dBc  |      |
| TWO-TONE SFDR                                     |                     |                     |           |      |           |      |      |           |      |      |      |
| $f_{IN} = 30.5$ MHz (-7 dBFS), 32.5 MHz (-7 dBFS) | 25°C                |                     |           |      |           | 78   |      |           | 78   |      | dBc  |
| ANALOG INPUT BANDWIDTH                            | 25°C                |                     | 700       |      |           | 700  |      |           | 700  |      | MHz  |

<sup>1</sup> See the [AN-835 Application Note](#), *Understanding High Speed ADC Testing and Evaluation*, for a complete set of definitions.

**DIGITAL SPECIFICATIONS**

AVDD = 1.8 V; DRVDD = 1.8 V, maximum sample rate, 2 V p-p differential input, 1.0 V internal reference; AIN = -1.0 dBFS, 50% duty cycle clock, DCS disabled, unless otherwise noted.

Table 3.

| Parameter   | Temp | AD9609-20/AD9609-40/AD9609-65/AD9609-80 |                  |             | Unit  |
|---|------|---|------------------|-------------|-------|
|   |      | Min                                     | Typ              | Max         |       |
| DIFFERENTIAL CLOCK INPUTS (CLK+, CLK-)                |      |   |                  |             |       |
| Logic Compliance                                      |      |   | CMOS/LVDS/LVPECL |             |       |
| Internal Common-Mode Bias                             | Full |   | 0.9              |             | V     |
| Differential Input Voltage                            | Full | 0.2                                     |                  | 3.6         | V p-p |
| Input Voltage Range                                   | Full | GND - 0.3                               |                  | AVDD + 0.2  | V     |
| High Level Input Current                              | Full | -10                                     |                  | +10         | μA    |
| Low Level Input Current                               | Full | -10                                     |                  | +10         | μA    |
| Input Resistance                                      | Full | 8                                       | 10               | 12          | kΩ    |
| Input Capacitance                                     | Full |   | 4                |             | pF    |
| LOGIC INPUTS (SCLK/DFS, MODE, SDIO/PDWN) <sup>1</sup> |      |   |                  |             |       |
| High Level Input Voltage                              | Full | 1.2                                     |                  | DRVDD + 0.3 | V     |
| Low Level Input Voltage                               | Full | 0                                       |                  | 0.8         | V     |
| High Level Input Current                              | Full | -50                                     |                  | -75         | μA    |
| Low Level Input Current                               | Full | -10                                     |                  | +10         | μA    |
| Input Resistance                                      | Full |   | 30               |             | kΩ    |
| Input Capacitance                                     | Full |   | 2                |             | pF    |
| LOGIC INPUTS (CSB) <sup>2</sup>                       |      |   |                  |             |       |
| High Level Input Voltage                              | Full | 1.2                                     |                  | DRVDD + 0.3 | V     |
| Low Level Input Voltage                               | Full | 0                                       |                  | 0.8         | V     |
| High Level Input Current                              | Full | -10                                     |                  | +10         | μA    |
| Low Level Input Current                               | Full | 40                                      |                  | 135         | μA    |
| Input Resistance                                      | Full |   | 26               |             | kΩ    |
| Input Capacitance                                     | Full |   | 2                |             | pF    |
| DIGITAL OUTPUTS                                       |      |   |                  |             |       |
| DRVDD = 3.3 V   |      |   |                  |             |       |
| High Level Output Voltage, I <sub>OH</sub> = 50 μA    | Full | 3.29                                    |                  |             | V     |
| High Level Output Voltage, I <sub>OH</sub> = 0.5 mA   | Full | 3.25                                    |                  |             | V     |
| Low Level Output Voltage, I <sub>OL</sub> = 1.6 mA    | Full |   |                  | 0.2         | V     |
| Low Level Output Voltage, I <sub>OL</sub> = 50 μA     | Full |   |                  | 0.05        | V     |
| DRVDD = 1.8 V   |      |   |                  |             |       |
| High Level Output Voltage, I <sub>OH</sub> = 50 μA    | Full | 1.79                                    |                  |             | V     |
| High Level Output Voltage, I <sub>OH</sub> = 0.5 mA   | Full | 1.75                                    |                  |             | V     |
| Low Level Output Voltage, I <sub>OL</sub> = 1.6 mA    | Full |   |                  | 0.2         | V     |
| Low Level Output Voltage, I <sub>OL</sub> = 50 μA     | Full |   |                  | 0.05        | V     |

<sup>1</sup> Internal 30 kΩ pull-down.

<sup>2</sup> Internal 30 kΩ pull-up.



**SWITCHING SPECIFICATIONS**

AVDD = 1.8 V; DRVDD = 1.8 V, maximum sample rate, 2 V p-p differential input, 1.0 V internal reference; AIN = -1.0 dBFS, 50% duty cycle clock, DCS disabled, unless otherwise noted.

Table 4.

| Parameter                                 | Temp | AD9609-20/AD9609-40 |           |       | AD9609-65 |      |     | AD9609-80 |      |     | Unit    |
|---|------|---------------------|-----------|-------|-----------|------|-----|-----------|------|-----|---------|
|   |      | Min                 | Typ       | Max   | Min       | Typ  | Max | Min       | Typ  | Max |         |
| <b>CLOCK INPUT PARAMETERS</b>             |      |                     |           |       |           |      |     |           |      |     |         |
| Input Clock Rate                          | Full |                     |           | 625   |           |      | 625 |           |      | 625 | MHz     |
| Conversion Rate <sup>1</sup>              | Full | 3                   |           | 20/40 | 3         |      | 65  | 3         |      | 80  | MSPS    |
| CLK Period—Divide-by-1 Mode ( $t_{CLK}$ ) | Full | 50/25               |           |       | 15.38     |      |     | 12.5      |      |     | ns      |
| CLK Pulse Width High ( $t_{CH}$ )         |      |                     | 25.0/12.5 |       |           | 7.69 |     |           | 6.25 |     | ns      |
| Aperture Delay ( $t_A$ )                  | Full |                     | 1.0       |       |           | 1.0  |     |           | 1.0  |     | ns      |
| Aperture Uncertainty (Jitter, $t_j$ )     | Full |                     | 0.1       |       |           | 0.1  |     |           | 0.1  |     | ps rms  |
| <b>DATA OUTPUT PARAMETERS</b>             |      |                     |           |       |           |      |     |           |      |     |         |
| Data Propagation Delay ( $t_{PD}$ )       | Full |                     | 3         |       |           | 3    |     |           | 3    |     | ns      |
| DCO Propagation Delay ( $t_{DCO}$ )       | Full |                     | 3         |       |           | 3    |     |           | 3    |     | ns      |
| DCO to Data Skew ( $t_{SKEW}$ )           | Full |                     | 0.1       |       |           | 0.1  |     |           | 0.1  |     | ns      |
| Pipeline Delay (Latency)                  | Full |                     | 8         |       |           | 8    |     |           | 8    |     | Cycles  |
| Wake-Up Time <sup>2</sup>                 | Full |                     | 350       |       |           | 350  |     |           | 350  |     | $\mu$ s |
| Standby                                   | Full |                     | 600/400   |       |           | 300  |     |           | 260  |     | ns      |
| <b>OUT-OF-RANGE RECOVERY TIME</b>         | Full |                     | 2         |       |           | 2    |     |           | 2    |     | Cycles  |

<sup>1</sup> Conversion rate is the clock rate after the CLK divider.

<sup>2</sup> Wake-up time is dependent on the value of the decoupling capacitors.

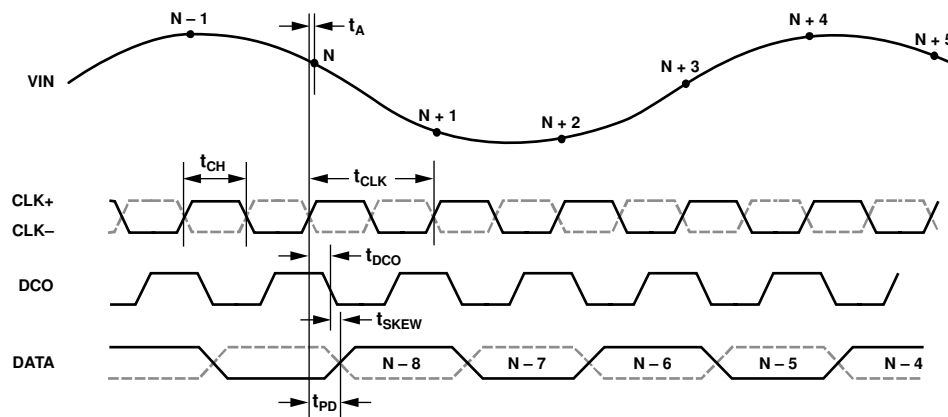

Figure 2. CMOS Output Data Timing

08541-002

## TIMING SPECIFICATIONS

Table 5.

| Parameter               | Conditions  | Min | Typ | Max | Unit |
|-------------------------|---|-----|-----|-----|------|
| SPI TIMING REQUIREMENTS |   |     |     |     |      |
| $t_{DS}$                | Setup time between the data and the rising edge of SCLK   | 2   |     |     | ns   |
| $t_{DH}$                | Hold time between the data and the rising edge of SCLK  | 2   |     |     | ns   |
| $t_{CLK}$               | Period of the SCLK  | 40  |     |     | ns   |
| $t_S$                   | Setup time between CSB and SCLK   | 2   |     |     | ns   |
| $t_H$                   | Hold time between CSB and SCLK  | 2   |     |     | ns   |
| $t_{HIGH}$              | SCLK pulse width high   | 10  |     |     | ns   |
| $t_{LOW}$               | SCLK pulse width low  | 10  |     |     | ns   |
| $t_{EN\_SDIO}$          | Time required for the SDIO pin to switch from an input to an output relative to the SCLK falling edge | 10  |     |     | ns   |
| $t_{DIS\_SDIO}$         | Time required for the SDIO pin to switch from an output to an input relative to the SCLK rising edge  | 10  |     |     | ns   |

## ABSOLUTE MAXIMUM RATINGS

Table 6.

| Parameter                               | Rating                  |
|---|-------------------------|
| AVDD to AGND                            | −0.3 V to +2.0 V        |
| DRVDD to AGND                           | −0.3 V to +3.9 V        |
| VIN+, VIN− to AGND                      | −0.3 V to AVDD + 0.2 V  |
| CLK+, CLK− to AGND                      | −0.3 V to AVDD + 0.2 V  |
| VREF to AGND                            | −0.3 V to AVDD + 0.2 V  |
| SENSE to AGND                           | −0.3 V to AVDD + 0.2 V  |
| VCM to AGND                             | −0.3 V to AVDD + 0.2 V  |
| RBIAS to AGND                           | −0.3 V to AVDD + 0.2 V  |
| CSB to AGND                             | −0.3 V to DRVDD + 0.3 V |
| SCLK/DFS to AGND                        | −0.3 V to DRVDD + 0.3 V |
| SDIO/PDWN to AGND                       | −0.3 V to DRVDD + 0.3 V |
| MODE/OR to AGND                         | −0.3 V to DRVDD + 0.3 V |
| D0 through D9 to AGND                   | −0.3 V to DRVDD + 0.3 V |
| DCO to AGND                             | −0.3 V to DRVDD + 0.3 V |
| Operating Temperature Range (Ambient)   | −40°C to +85°C          |
| Maximum Junction Temperature Under Bias | 150°C                   |
| Storage Temperature Range (Ambient)     | −65°C to +150°C         |

Stresses at or above those listed under Absolute Maximum Ratings may cause permanent damage to the product. This is a stress rating only; functional operation of the product at these or any other conditions above those indicated in the operational section of this specification is not implied. Operation beyond the maximum operating conditions for extended periods may affect product reliability.

## THERMAL CHARACTERISTICS

The exposed paddle is the only ground connection for the chip. The exposed paddle must be soldered to the AGND plane of the user's circuit board. Soldering the exposed paddle to the user's board also increases the reliability of the solder joints and maximizes the thermal capability of the package.

Table 7. Thermal Resistance

| Package Type                 | Airflow Velocity (m/sec) | $\theta_{JA}^{1,2}$ | $\theta_{JC}^{1,3}$ | $\theta_{JB}^{1,4}$ | $\Psi_{JT}^{1,2}$ | Unit |
|------------------------------|--------------------------|---------------------|---------------------|---------------------|-------------------|------|
| 32-Lead LFCSP<br>5 mm × 5 mm | 0                        | 37.1                | 3.1                 | 20.7                | 0.3               | °C/W |
|                              | 1.0                      | 32.4                |                     |                     | 0.5               | °C/W |
|                              | 2.5                      | 29.1                |                     |                     | 0.8               | °C/W |

<sup>1</sup> Per JEDEC 51-7, plus JEDEC 51-5 2S2P test board.

<sup>2</sup> Per JEDEC JESD51-2 (still air) or JEDEC JESD51-6 (moving air).

<sup>3</sup> Per MIL-Std 883, Method 1012.1.

<sup>4</sup> Per JEDEC JESD51-8 (still air).

Typical  $\theta_{JA}$  is specified for a 4-layer PCB with a solid ground plane. As shown in Table 7, airflow improves heat dissipation, which reduces  $\theta_{JA}$ . In addition, metal in direct contact with the package leads from metal traces, through holes, ground, and power planes, reduces the  $\theta_{JA}$ .

## ESD CAUTION



**ESD (electrostatic discharge) sensitive device.** Charged devices and circuit boards can discharge without detection. Although this product features patented or proprietary protection circuitry, damage may occur on devices subjected to high energy ESD. Therefore, proper ESD precautions should be taken to avoid performance degradation or loss of functionality.

## PIN CONFIGURATION AND FUNCTION DESCRIPTIONS

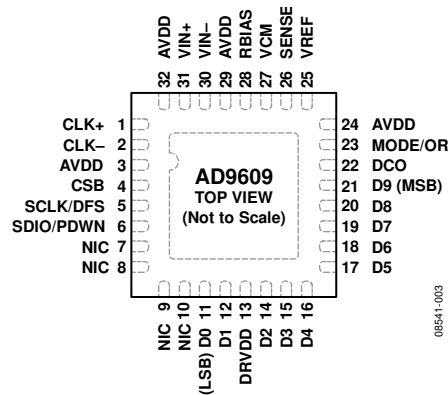

## NOTES

1. NIC = NO INTERNAL CONNECTION.
2. EXPOSED PADDLE. THE EXPOSED PADDLE IS THE ONLY GROUND CONNECTION. IT MUST BE SOLDERED TO THE ANALOG GROUND OF THE PCB TO ENSURE PROPER FUNCTIONALITY AND HEAT DISSIPATION, NOISE, AND MECHANICAL STRENGTH BENEFITS.

Figure 3. Pin Configuration

Table 8. Pin Function Descriptions

| Pin No.            | Mnemonic             | Description   |
|--------------------|----------------------|---|
| 0                  | EPAD                 | Exposed Paddle. The exposed paddle is the only ground connection. It must be soldered to the analog ground of the PCB to ensure proper functionality and heat dissipation, noise, and mechanical strength benefits.   |
| 1, 2               | CLK+, CLK-           | Differential Encode Clock for PECL, LVDS, or 1.8 V CMOS Inputs.   |
| 3, 24, 29, 32      | AVDD                 | 1.8 V Supply Pin for ADC Core Domain.   |
| 4                  | CSB                  | SPI Chip Select. Active low enable, 30 k $\Omega$ internal pull-up.   |
| 5                  | SCLK/DFS             | SPI Clock Input in SPI Mode (SCLK). 30 k $\Omega$ internal pull-down.<br>Data Format Select in Non-SPI Mode (DFS). Static control of data output format. 30 k $\Omega$ internal pull-down. DFS high = twos complement output; DFS low = offset binary output.   |
| 6                  | SDIO/PDWN            | SPI Data Input/Output (SDIO). Bidirectional SPI data I/O with 30 k $\Omega$ internal pull-down.<br>Non-SPI Mode Power-Down (PDWN). Static control of chip power-down with 30 k $\Omega$ internal pull-down. See Table 15 for details.   |
| 7 to 10            | NIC                  | No Internal Connection.   |
| 11 to 12, 14 to 21 | D0 (LSB) to D9 (MSB) | ADC Digital Outputs.  |
| 13                 | DRVDD                | 1.8 V to 3.3 V Supply Pin for Output Driver Domain.   |
| 22                 | DCO                  | Data Clock Digital Output.  |
| 23                 | MODE/OR              | Chip Mode Select Input (MODE)/Out-of-Range Digital Output in SPI Mode (OR).<br>Default = out-of-range (OR) digital output (SPI Register 0x2A, Bit 0 = 1).<br>Option = chip mode select input (SPI Register 0x2A, Bit 0 = 0).<br>Chip power-down (SPI Register 0x08, Bits[7:5] = 100b).<br>Chip stand-by (SPI Register 0x08, Bits[7:5] = 101b).<br>Normal operation, output disabled (SPI Register 0x08, Bits[7:5] = 110b).<br>Normal operation, output enabled (SPI Register 0x08, Bits[7:5] = 111b).<br>Out-of-range (OR) digital output only in non-SPI mode. |
| 25                 | VREF                 | 1.0 V Voltage Reference Input/Output. See Table 10.   |
| 26                 | SENSE                | Reference Mode Selection. See Table 10.   |
| 27                 | VCM                  | Analog Output Voltage at Mid AVDD Supply. Sets common mode of the analog inputs.  |
| 28                 | RBIAS                | Set Analog Current Bias. Connect to 10 k $\Omega$ (1% tolerance) resistor to ground.  |
| 30, 31             | VIN-, VIN+           | ADC Analog Inputs.  |

# TYPICAL PERFORMANCE CHARACTERISTICS

## AD9609-80

AVDD = 1.8 V; DRVDD = 1.8 V, maximum sample rate, 2 V p-p differential input, 1.0 V internal reference; AIN = -1.0 dBFS, 50% duty cycle clock, DCS disabled, unless otherwise noted.

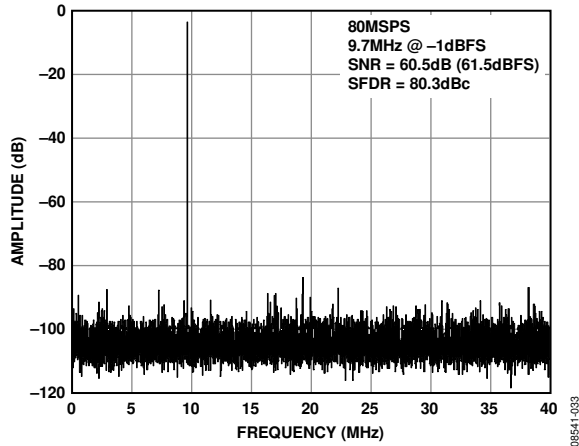

Figure 4. AD9609-80 Single-Tone FFT with  $f_{IN} = 9.7$  MHz

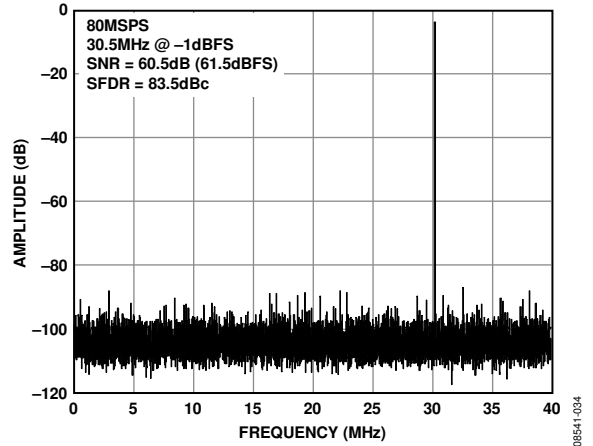

Figure 7. AD9609-80 Single-Tone FFT with  $f_{IN} = 30.5$  MHz

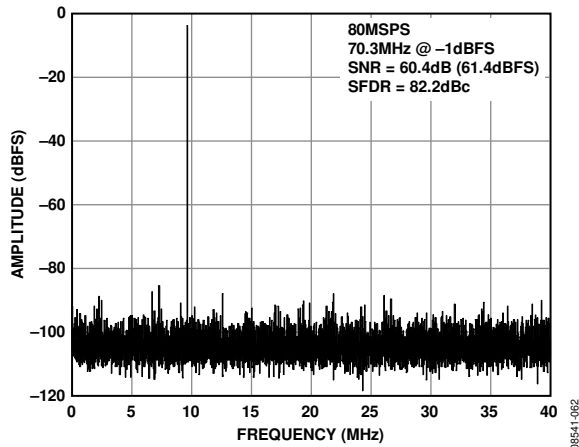

Figure 5. AD9609-80 Single-Tone FFT with  $f_{IN} = 70.3$  MHz

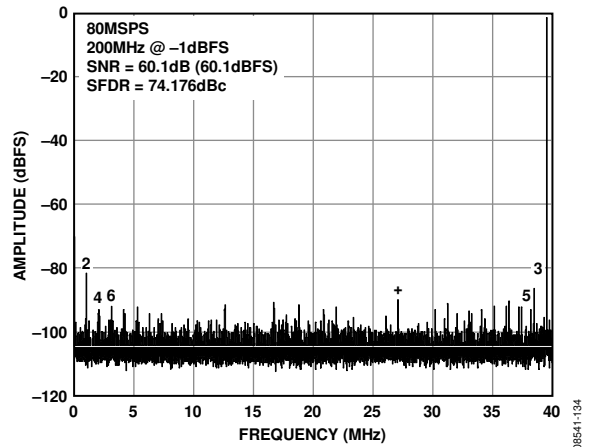

Figure 8. AD9609-80 Single-Tone FFT with  $f_{IN} = 200$  MHz

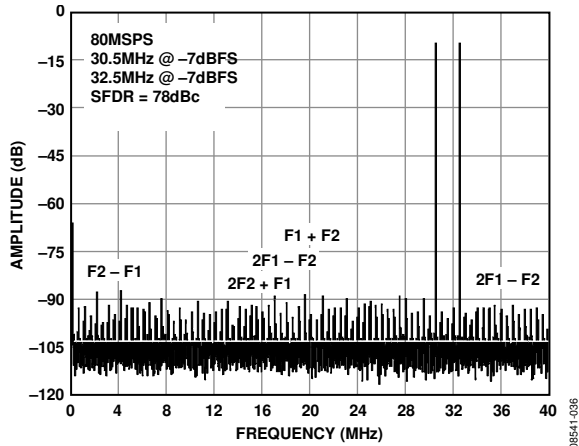

Figure 6. AD9609-80 Two-Tone FFT with  $f_{IN1} = 30.5$  MHz and  $f_{IN2} = 32.5$  MHz

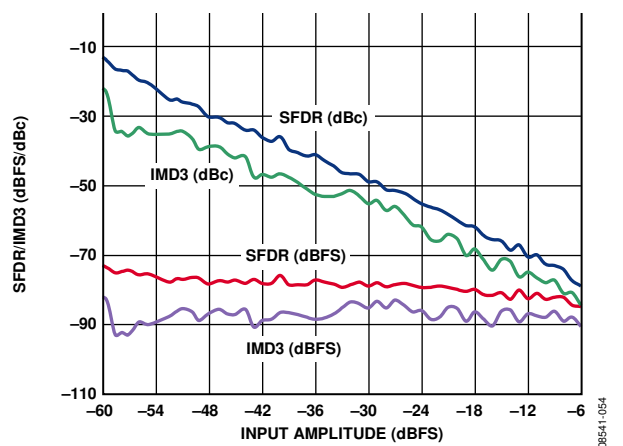

Figure 9. Two-Tone SFDR/IMD3 vs. Input Amplitude ( $A_{IN}$ ) with  $f_{IN1} = 30.5$  MHz and  $f_{IN2} = 32.5$  MHz

AVDD = 1.8 V; DRVDD = 1.8 V, maximum sample rate, 2 V p-p differential input, 1.0 V internal reference; AIN = -1.0 dBFS, 50% duty cycle clock, DCS disabled, unless otherwise noted.

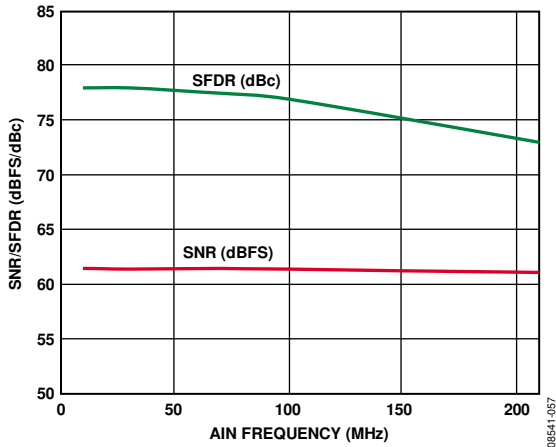

Figure 10. AD9609-80 SNR/SFDR vs. Input Frequency (AIN) with 2 V p-p Full Scale

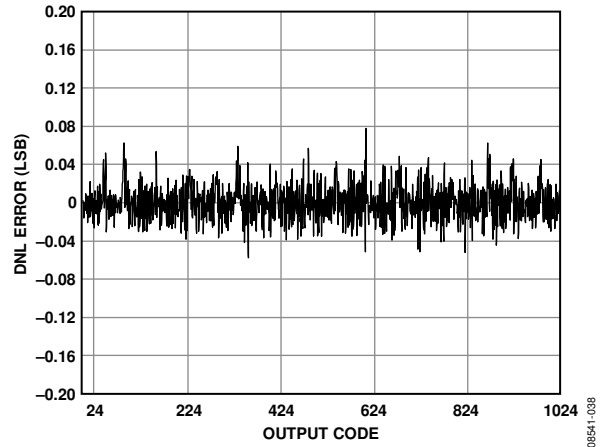

Figure 13. DNL Error with  $f_{IN} = 9.7$  MHz

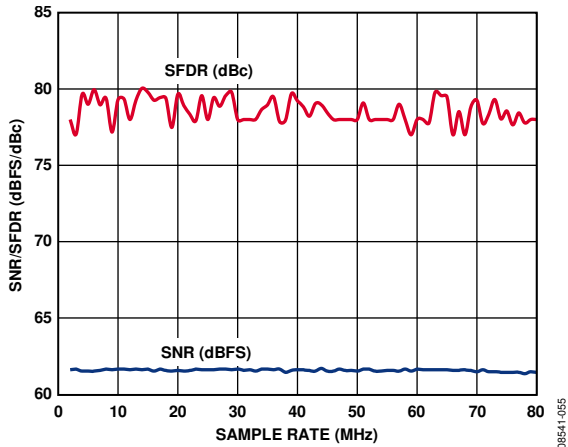

Figure 11. AD9609-80 SNR/SFDR vs. Sample Rate with AIN = 9.7 MHz

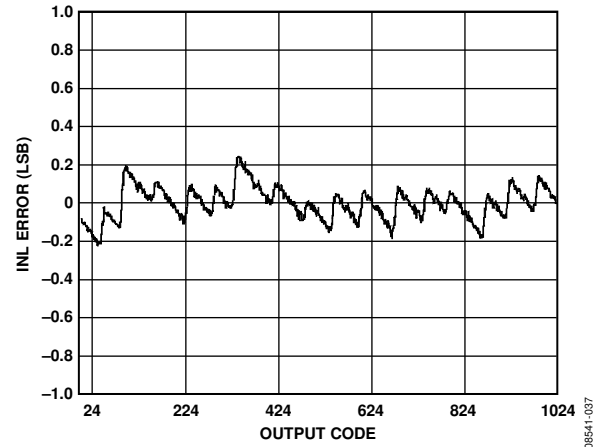

Figure 14. INL with  $f_{IN} = 9.7$  MHz

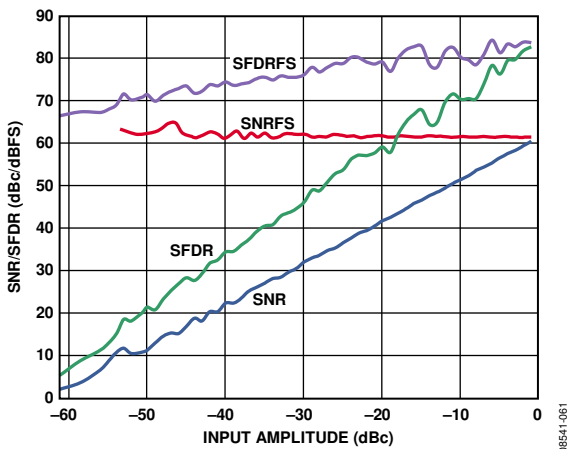

Figure 12. AD9609-80 SNR/SFDR vs. Input Amplitude (AIN) with  $f_{IN} = 9.7$  MHz



**AD9609-65**

AVDD = 1.8 V; DRVDD = 1.8 V, maximum sample rate, 2 V p-p differential input, 1.0 V internal reference; AIN = -1.0 dBFS, 50% duty cycle clock, DCS disabled, unless otherwise noted.

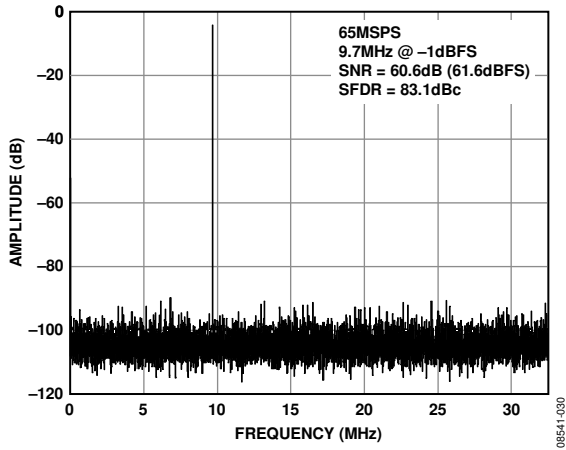

Figure 15. AD9609-65 Single-Tone FFT with  $f_{IN} = 9.7$  MHz

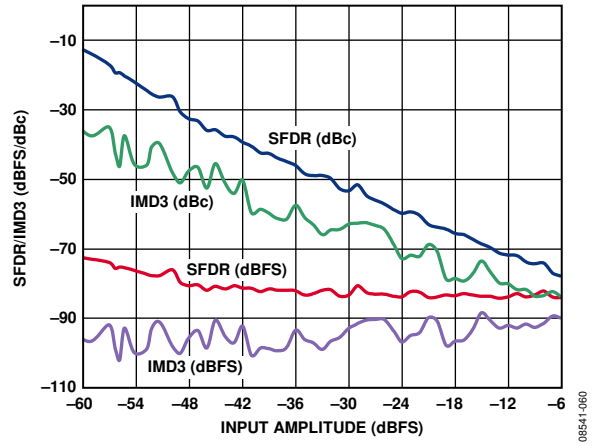

Figure 18. AD9609-65 SNR/SFDR vs. Input Amplitude (AIN) with  $f_{IN} = 9.7$  MHz

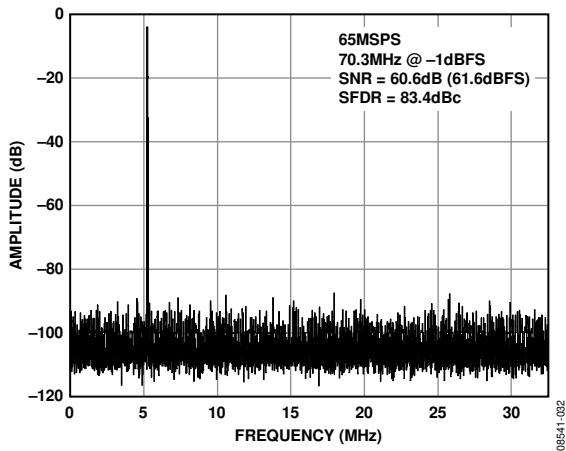

Figure 16. AD9609-65 Single-Tone FFT with  $f_{IN} = 70.3$  MHz

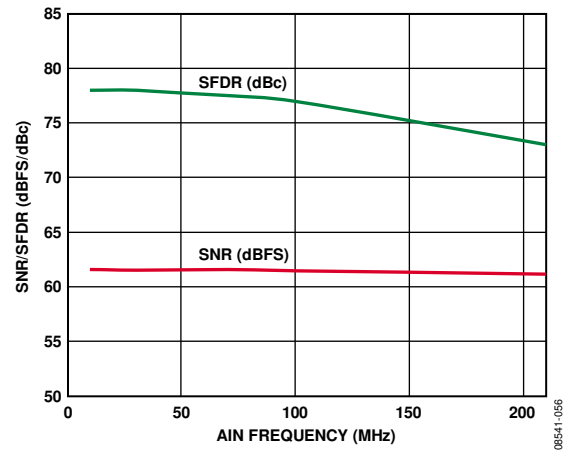

Figure 19. AD9609-65 SNR/SFDR vs. Input Frequency (AIN) with 2V p-p Full Scale

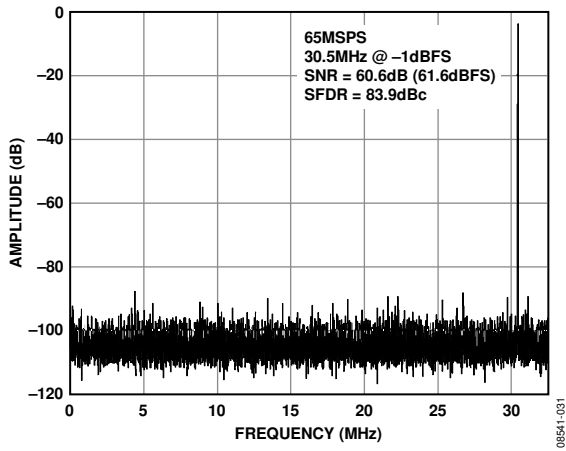

Figure 17. AD9609-65 Single-Tone FFT with  $f_{IN} = 30.5$  MHz

AD9609-40

AVDD = 1.8 V; DRVDD = 1.8 V, maximum sample rate, 2 V p-p differential input, 1.0 V internal reference; AIN = -1.0 dBFS, 50% duty cycle clock, DCS disabled, unless otherwise noted.

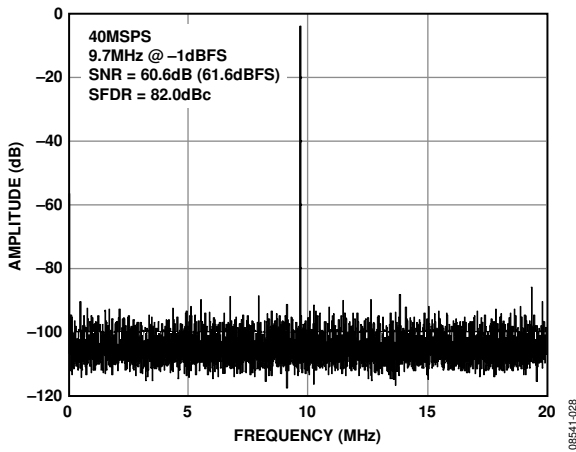

Figure 20. AD9609-40 Single-Tone FFT with  $f_{IN} = 9.7$  MHz

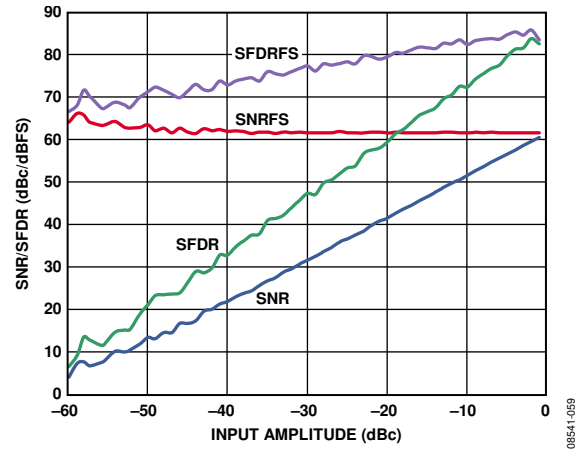

Figure 22. AD9609-40 SNR/SFDR vs. Input Amplitude (AIN) with  $f_{IN} = 9.7$  MHz

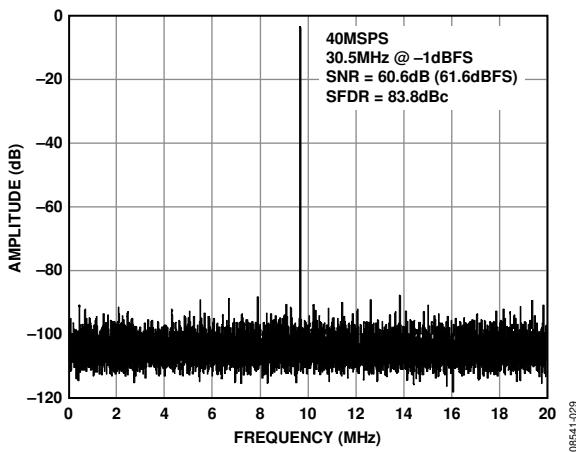

Figure 21. AD9609-40 Single-Tone FFT with  $f_{IN} = 30.5$  MHz

**AD9609-20**

AVDD = 1.8 V; DRVDD = 1.8 V, maximum sample rate, 2 V p-p differential input, 1.0 V internal reference; AIN = -1.0 dBFS, 50% duty cycle clock, DCS disabled, unless otherwise noted.

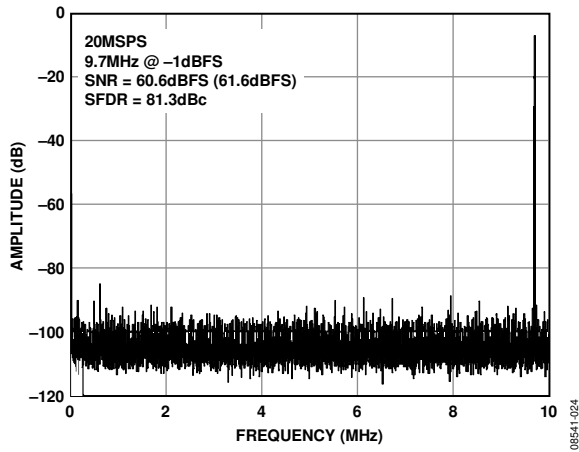

Figure 23. AD9609-20 Single-Tone FFT with  $f_{IN} = 9.7$  MHz

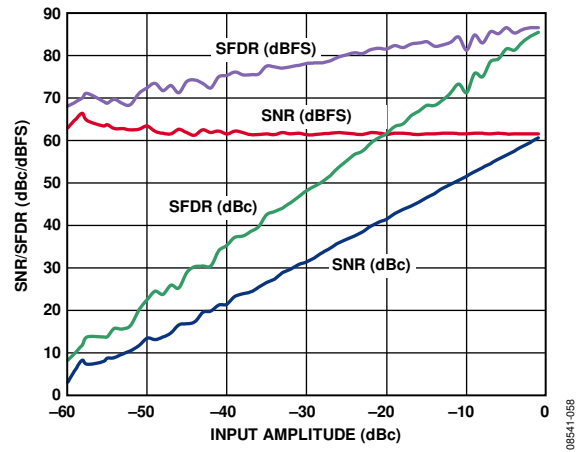

Figure 25. AD9609-20 SNR/SFDR vs. Input Amplitude (AIN) with  $f_{IN} = 9.7$  MHz

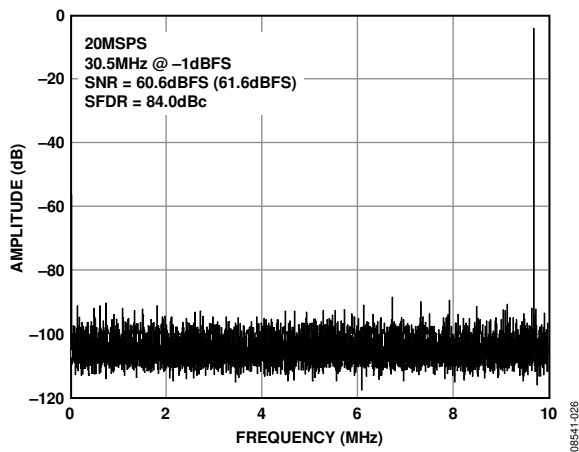

Figure 24. AD9609-20 Single-Tone FFT with  $f_{IN} = 30.5$  MHz

# EQUIVALENT CIRCUITS

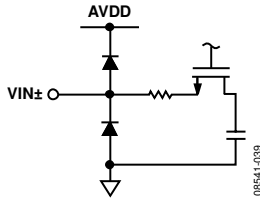

Figure 26. Equivalent Analog Input Circuit

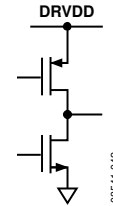

Figure 30. Equivalent D0 to D9 and OR Digital Output Circuit

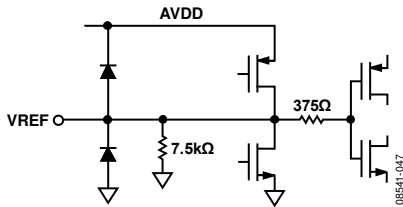

Figure 27. Equivalent VREF Circuit

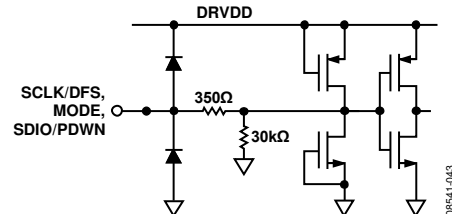

Figure 31. Equivalent SCLK/DFS, MODE, and SDIO/PDWN Input Circuit

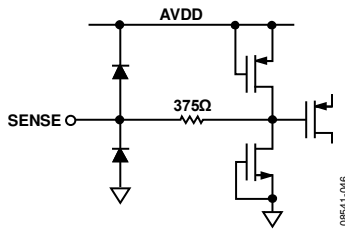

Figure 28. Equivalent SENSE Circuit

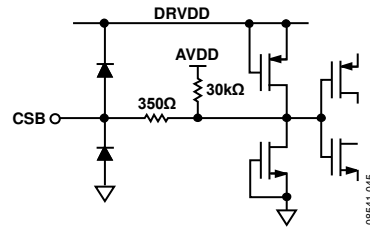

Figure 32. Equivalent CSB Input Circuit

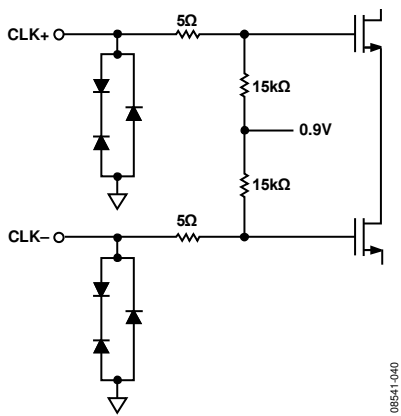

Figure 29. Equivalent Clock Input Circuit

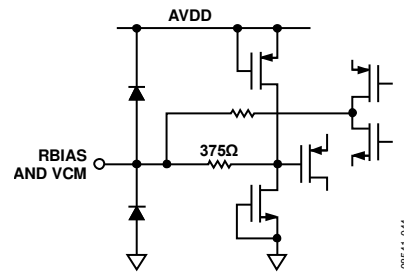

Figure 33. Equivalent RBIAS and VCM Circuit

## THEORY OF OPERATION

The AD9609 architecture consists of a multistage, pipelined ADC. Each stage provides sufficient overlap to correct for flash errors in the preceding stage. The quantized outputs from each stage are combined into a final 10-bit result in the digital correction logic. The pipelined architecture permits the first stage to operate with a new input sample while the remaining stages operate with preceding samples. Sampling occurs on the rising edge of the clock.

Each stage of the pipeline, excluding the last, consists of a low resolution flash ADC connected to a switched-capacitor DAC and an interstage residue amplifier (for example, a multiplying digital-to-analog converter (MDAC)). The residue amplifier magnifies the difference between the reconstructed DAC output and the flash input for the next stage in the pipeline. One bit of redundancy is used in each stage to facilitate digital correction of flash errors. The last stage simply consists of a flash ADC.

The output staging block aligns the data, corrects errors, and passes the data to the CMOS output buffers. The output buffers are powered from a separate (DRVDD) supply, allowing adjustment of the output voltage swing. During power-down, the output buffers go into a high impedance state.

### ANALOG INPUT CONSIDERATIONS

The analog input to the AD9609 is a differential switched-capacitor circuit designed for processing differential input signals. This circuit can support a wide common-mode range while maintaining excellent performance. By using an input common-mode voltage of midsupply, users can minimize signal-dependent errors and achieve optimum performance.

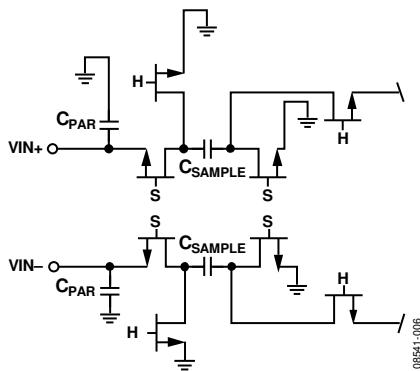

Figure 34. Switched-Capacitor Input Circuit

The clock signal alternately switches the input circuit between sample-and-hold mode (see Figure 34). When the input circuit is switched to sample mode, the signal source must be capable of charging the sample capacitors and settling within one-half of a clock cycle. A small resistor in series with each input can help reduce the peak transient current injected from the output stage of the driving source. In addition, low Q inductors or ferrite beads can be placed on each leg of the input to reduce high differential capacitance at the analog inputs and, therefore, achieve the maximum bandwidth of the ADC. Such use of low Q inductors or ferrite beads is required when driving the converter front end at

high IF frequencies. Either a shunt capacitor or two single-ended capacitors can be placed on the inputs to provide a matching passive network. This ultimately creates a low-pass filter at the input to limit unwanted broadband noise. See the AN-742 Application Note, the AN-827 Application Note, and the Analog Dialogue article “Transformer-Coupled Front-End for Wideband A/D Converters” (Volume 39, April 2005) for more information. In general, the precise values depend on the application.

### Input Common Mode

The analog inputs of the AD9609 are not internally dc-biased. Therefore, in ac-coupled applications, the user must provide a dc bias externally. Setting the device so that  $V_{CM} = AV_{DD}/2$  is recommended for optimum performance, but the device can function over a wider range with reasonable performance, as shown in Figure 35 and Figure 36.

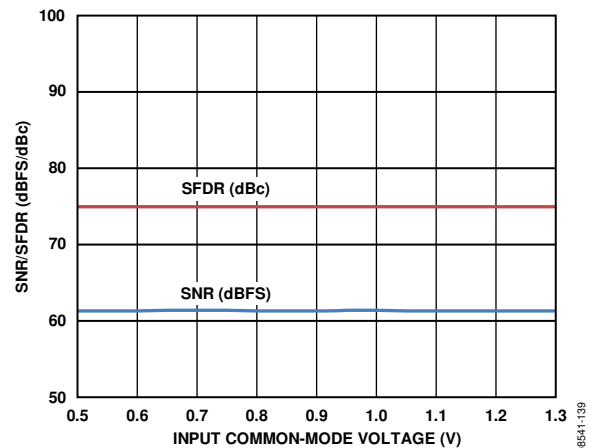

Figure 35. SNR/SFDR vs. Input Common-Mode Voltage,  $f_{IN} = 32.1$  MHz,  $f_S = 80$  MSPS

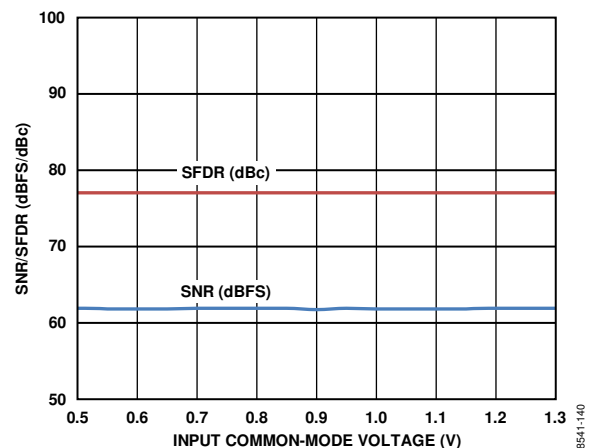

Figure 36. SNR/SFDR vs. Input Common-Mode Voltage,  $f_{IN} = 10.3$  MHz,  $f_S = 20$  MSPS

An on-board, common-mode voltage reference is included in the design and is available from the VCM pin. The VCM pin must be decoupled to ground by a 0.1  $\mu$ F capacitor, as described in the Applications Information section.

**Differential Input Configurations**

Optimum performance is achieved while driving the AD9609 in a differential input configuration. For baseband applications, the AD8138, ADA4937-2, and ADA4938-2 differential drivers provide excellent performance and a flexible interface to the ADC. The output common-mode voltage of the ADA4938-2 is easily set with the VCM pin of the AD9609 (see Figure 37), and the driver can be configured in a Sallen-Key filter topology to provide band limiting of the input signal.

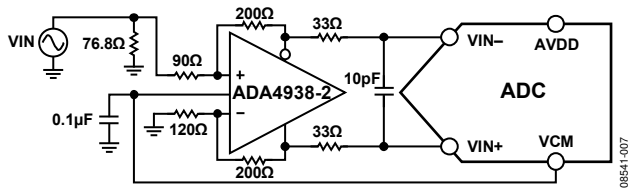

Figure 37. Differential Input Configuration Using the ADA4938-2

For baseband applications below ~10 MHz where SNR is a key parameter, differential transformer-coupling is the recommended input configuration. An example is shown in Figure 38. To bias the analog input, the VCM voltage can be connected to the center tap of the secondary winding of the transformer.

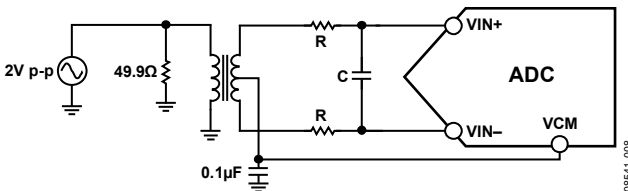

Figure 38. Differential Transformer-Coupled Configuration

The signal characteristics must be considered when selecting a transformer. Most RF transformers saturate at frequencies below a few megahertz (MHz). Excessive signal power can also cause core saturation, which leads to distortion.

At input frequencies in the second Nyquist zone and above, the noise performance of most amplifiers is not adequate to achieve the true SNR performance of the AD9609. For applications above ~10 MHz where SNR is a key parameter, differential double balun coupling is the recommended input configuration (see Figure 40).

An alternative to using a transformer-coupled input at frequencies in the second Nyquist zone is to use the AD8352 differential driver. An example is shown in Figure 41. See the AD8352 data sheet for more information.

In any configuration, the value of Shunt Capacitor C is dependent on the input frequency and source impedance and may need to be reduced or removed. Table 9 displays the suggested values to set the RC network. However, these values are dependent on the input signal and should be used only as a starting guide.

**Table 9. Example RC Network**

| Frequency Range (MHz) | R Series (Ω Each) | C Differential (pF) |
|-----------------------|-------------------|---------------------|
| 0 to 70               | 33                | 22                  |
| 70 to 200             | 125               | Open                |

**Single-Ended Input Configuration**

A single-ended input can provide adequate performance in cost-sensitive applications. In this configuration, SFDR and distortion performance degrade due to the large input common-mode swing. If the source impedances on each input are matched, there should be little effect on SNR performance. Figure 39 shows a typical single-ended input configuration.

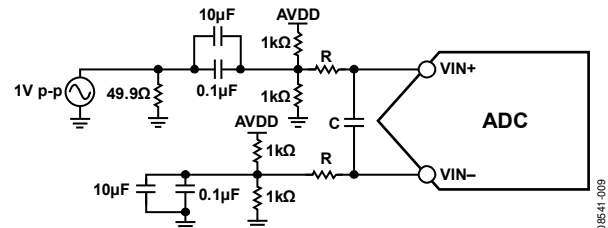

Figure 39. Single-Ended Input Configuration

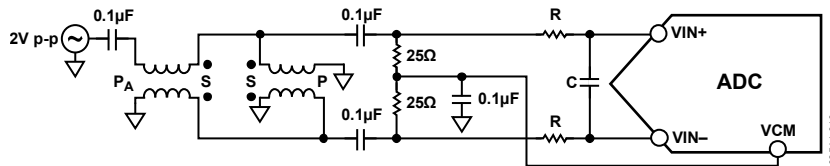

Figure 40. Differential Double Balun Input Configuration

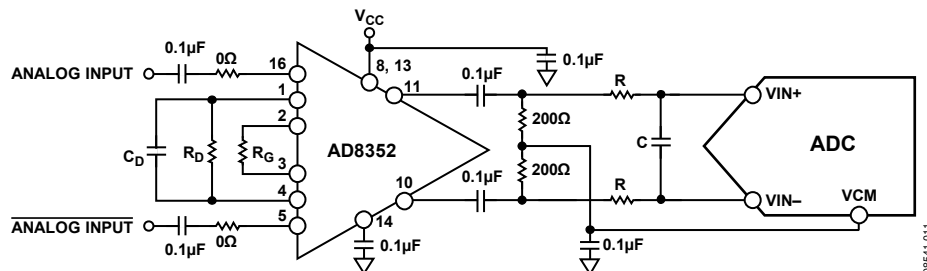

Figure 41. Differential Input Configuration Using the AD8352



**VOLTAGE REFERENCE**

A stable and accurate 1.0 V voltage reference is built into the AD9609. The VREF can be configured using either the internal 1.0 V reference or an externally applied 1.0 V reference voltage. The various reference modes are summarized in the sections that follow. The Reference Decoupling section describes the best practices for PCB layout of VREF.

**Internal Reference Connection**

A comparator within the AD9609 detects the potential at the SENSE pin and configures the reference into two possible modes, which are summarized in Table 10. If SENSE is grounded, the reference amplifier switch is connected to the internal resistor divider (see Figure 42), setting VREF to 1.0 V.

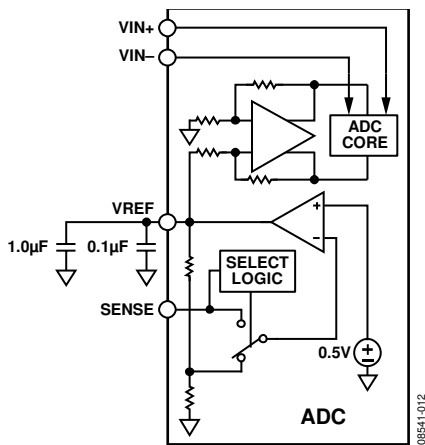

Figure 42. Internal Reference Configuration

In either internal or external reference mode, the maximum input range of the ADC can be varied by configuring SPI Address 0x18 as shown in Table 11, resulting in a selectable differential span from 1 V p-p to 2 V p-p.

If the internal reference of the AD9609 is used to drive multiple converters to improve gain matching, the loading of the reference by the other converters must be considered. Figure 43 shows how the internal reference voltage is affected by loading.

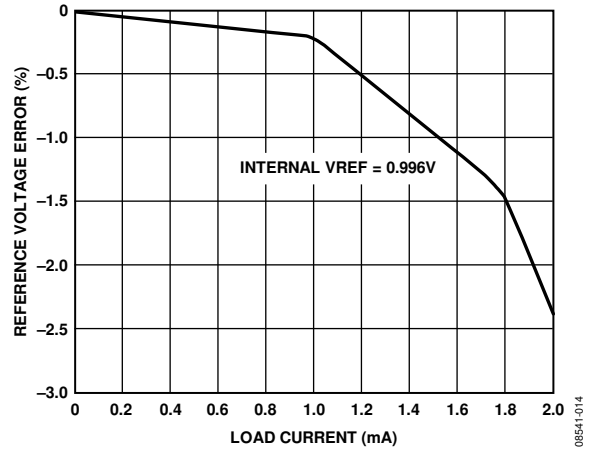

Figure 43. VREF Accuracy vs. Load Current

**External Reference Operation**

The use of an external reference may be necessary to enhance the gain accuracy of the ADC or improve thermal drift characteristics. Figure 44 shows the typical drift characteristics of the internal reference in 1.0 V mode.

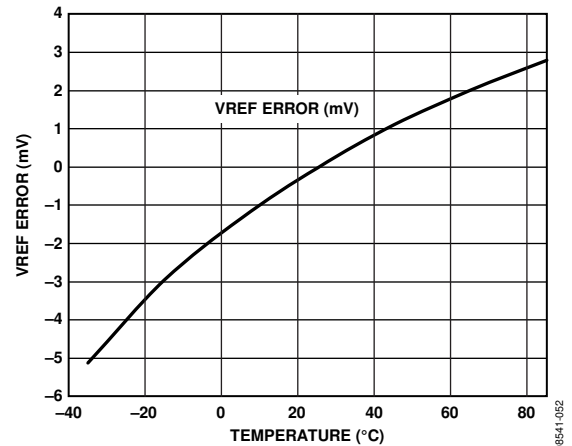

Figure 44. Typical VREF Drift

When the SENSE pin is tied to AVDD, the internal reference is disabled, allowing the use of an external reference. An internal reference buffer loads the external reference with an equivalent 7.5 kΩ load (see Figure 27). The internal buffer generates the positive and negative full-scale references for the ADC core. Therefore, the external reference must be limited to a maximum of 1.0 V.

Table 10. Reference Configuration Summary

| Selected Mode            | SENSE Voltage (V) | Resulting VREF (V)               | Resulting Differential Span (V p-p) |
|--------------------------|-------------------|----------------------------------|-------------------------------------|
| Fixed Internal Reference | AGND to 0.2       | 1.0 internal                     | 2.0                                 |
| Fixed External Reference | AVDD              | 1.0 applied to external VREF pin | 2.0                                 |

Table 11. Scaled Differential Span Summary

| Selected Mode                        | Resulting VREF (V)         | SPI Register 0x18 (Hex) | Resulting Differential Span (V p-p) |
|--------------------------------------|----------------------------|-------------------------|-------------------------------------|
| Fixed Internal or External Reference | 1.0 (internal or external) | 0xC0                    | 1.0                                 |
| Fixed Internal or External Reference | 1.0 (internal or external) | 0xC8                    | 1.14                                |
| Fixed Internal or External Reference | 1.0 (internal or external) | 0xD0                    | 1.33                                |
| Fixed Internal or External Reference | 1.0 (internal or external) | 0xD8                    | 1.6                                 |
| Fixed Internal or External Reference | 1.0 (internal or external) | 0xE0                    | 2.0                                 |

**CLOCK INPUT CONSIDERATIONS**

For optimum performance, clock the AD9609 sample clock inputs, CLK+ and CLK-, with a differential signal. The signal is typically ac-coupled into the CLK+ and CLK- pins via a transformer or capacitors. These pins are biased internally (see Figure 45) and require no external bias.

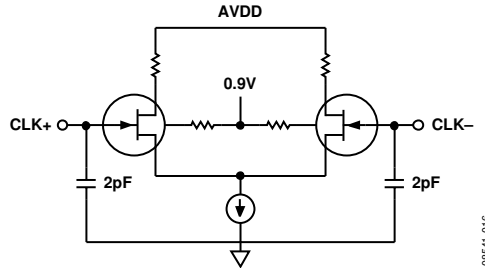

Figure 45. Equivalent Clock Input Circuit

**Clock Input Options**

The AD9609 has a very flexible clock input structure. The clock input can be a CMOS, LVDS, LVPECL, or sine wave signal. Regardless of the type of signal being used, clock source jitter is of great concern, as described in the Jitter Considerations section.

Figure 46 and Figure 47 show two preferred methods for clocking the AD9609 (at clock rates up to 625 MHz). A low jitter clock source is converted from a single-ended signal to a differential signal using either an RF transformer or an RF balun.

The RF balun configuration is recommended for clock frequencies between 125 MHz and 625 MHz, and the RF transformer is recommended for clock frequencies from 10 MHz to 200 MHz. The back-to-back Schottky diodes across the transformer/balun secondary limit clock excursions into the AD9609 to approximately 0.8 V p-p differential.

This limit helps prevent the large voltage swings of the clock from feeding through to other portions of the AD9609 while preserving the fast rise and fall times of the signal that are critical to a low jitter performance.

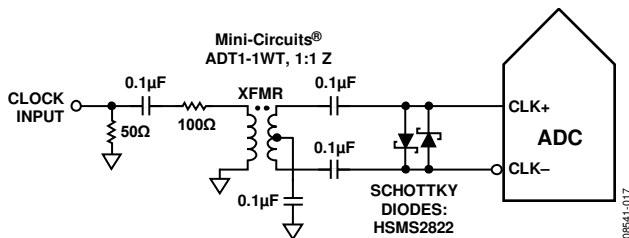

Figure 46. Transformer-Coupled Differential Clock (Up to 200 MHz)

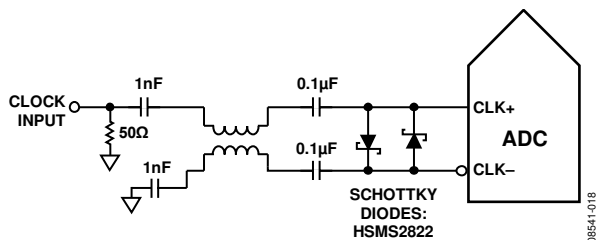

Figure 47. Balun-Coupled Differential Clock (Up to 625 MHz)

If a low jitter clock source is not available, another option is to ac couple a differential PECL signal to the sample clock input pins, as shown in Figure 48. The AD9510/AD9511/AD9512/AD9513/AD9514/AD9515/AD9516-4/AD9517-4 clock drivers offer excellent jitter performance.

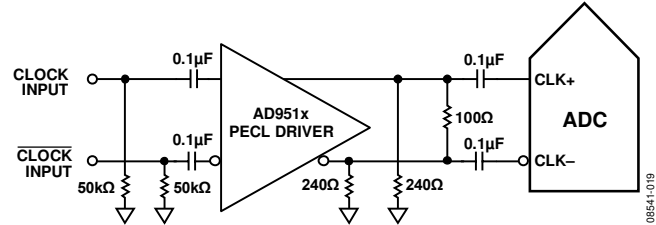

Figure 48. Differential PECL Sample Clock (Up to 625 MHz)

A third option is to ac couple a differential LVDS signal to the sample clock input pins, as shown in Figure 49. The AD9510/AD9511/AD9512/AD9513/AD9514/AD9515/AD9516-4/AD9517-4 clock drivers offer excellent jitter performance.

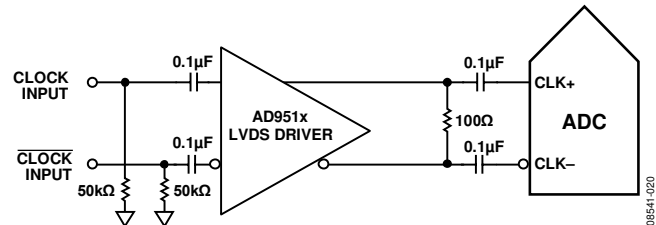

Figure 49. Differential LVDS Sample Clock (Up to 625 MHz)

In some applications, it may be acceptable to drive the sample clock inputs with a single-ended 1.8 V CMOS signal. In such applications, drive the CLK+ pin directly from a CMOS gate, and bypass the CLK- pin to ground with a 0.1 μF capacitor (see Figure 50).

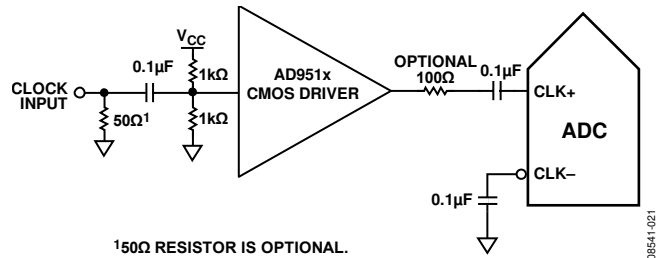

Figure 50. Single-Ended 1.8 V CMOS Input Clock (Up to 200 MHz)

**Input Clock Divider**

The AD9609 contains an input clock divider with the ability to divide the input clock by integer values between 1 and 8. Optimum performance can be obtained by enabling the internal duty cycle stabilizer (DCS) when using divide ratios other than 1, 2, or 4.

**Clock Duty Cycle**

Typical high speed ADCs use both clock edges to generate a variety of internal timing signals and, as a result, may be sensitive to clock duty cycle. Commonly, a ±5% tolerance is required on the clock duty cycle to maintain dynamic performance characteristics.

The AD9609 contains a duty cycle stabilizer (DCS) that retimes the nonsampling (falling) edge, providing an internal clock signal with a nominal 50% duty cycle. This allows the user to provide a wide range of clock input duty cycles without affecting the performance of the AD9609. Noise and distortion performance are nearly flat for a wide range of duty cycles with the DCS on, as shown in Figure 51.

Jitter in the rising edge of the input is still of concern and is not easily reduced by the internal stabilization circuit. The duty cycle control loop does not function for clock rates less than 20 MHz nominally. The loop has a time constant associated with it that must be considered in applications in which the clock rate can change dynamically. A wait time of 1.5 μs to 5 μs is required after a dynamic clock frequency increase or decrease before the DCS loop is relocked to the input signal.

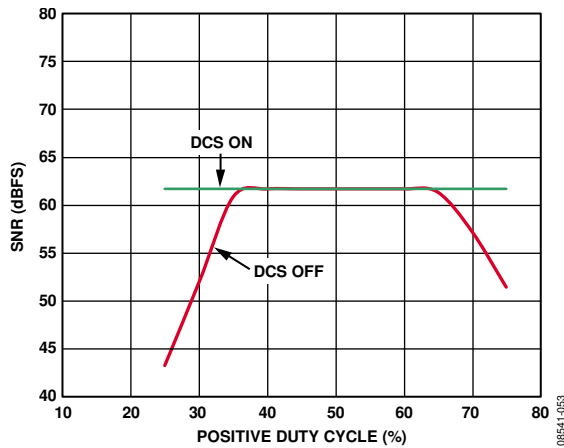

Figure 51. SNR vs. DCS On/Off

**Jitter Considerations**

High speed, high resolution ADCs are sensitive to the quality of the clock input. The degradation in SNR from the low frequency SNR ( $SNR_{LF}$ ) at a given input frequency ( $f_{INPUT}$ ) due to jitter ( $t_{J_{RMS}}$ ) can be calculated by

$$SNR_{HF} = -10 \log[(2\pi \times f_{INPUT} \times t_{J_{RMS}})^2 + 10^{(-SNR_{LF}/10)}]$$

In the previous equation, the rms aperture jitter represents the clock input jitter specification. IF undersampling applications are particularly sensitive to jitter, as illustrated in Figure 52.

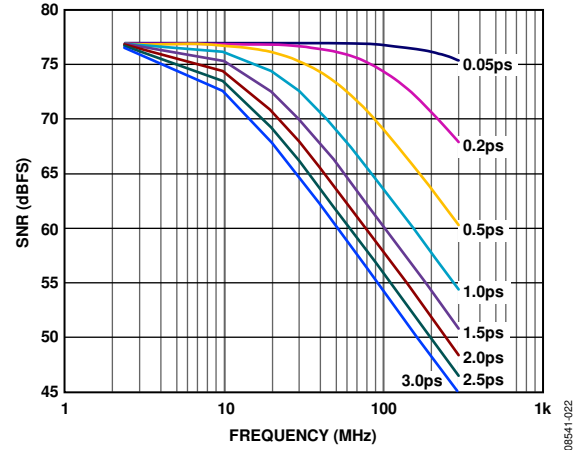

Figure 52. SNR vs. Input Frequency and Jitter

The clock input should be treated as an analog signal when aperture jitter may affect the dynamic range of the AD9609. To avoid modulating the clock signal with digital noise, keep power supplies for clock drivers separate from the ADC output driver supplies. Low jitter, crystal-controlled oscillators make the best clock sources. If the clock is generated from another type of source (by gating, dividing, or another method), it should be retimed by the original clock at the last step.

For more information, see the [AN-501 Application Note](#) and the [AN-756 Application Note](#).

## POWER DISSIPATION AND STANDBY MODE

As shown in Figure 53, the analog core power dissipated by the AD9609 is proportional to its sample rate. The digital power dissipation of the CMOS outputs are determined primarily by the strength of the digital drivers and the load on each output bit.

The maximum DRVDD current (IDRVDD) can be calculated as

$$IDRVDD = V_{DRVDD} \times C_{LOAD} \times f_{CLK} \times N$$

where  $N$  is the number of output bits (22, in the case of the AD9609).

This maximum current occurs when every output bit switches on every clock cycle, that is, a full-scale square wave at the Nyquist frequency of  $f_{CLK}/2$ . In practice, the DRVDD current is established by the average number of output bits switching, which is determined by the sample rate and the characteristics of the analog input signal.

Reducing the capacitive load presented to the output drivers can minimize digital power consumption. The data in Figure 53 was taken using the same operating conditions as those used for the Typical Performance Characteristics, with a 5 pF load on each output driver.

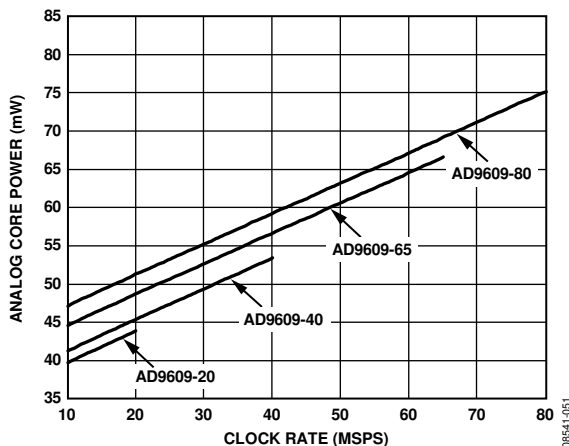

Figure 53. AD9609 Analog Core Power vs. Clock Rate

In SPI mode, the AD9609 can be placed in power-down mode directly via the SPI port, or by using the programmable external MODE pin. In non-SPI mode, power-down is achieved by asserting the PDWN pin high. In this state, the ADC typically dissipates 500  $\mu$ W. During power-down, the output drivers are placed in a high impedance state. Asserting PDWN low (or the MODE pin in SPI mode) returns the AD9609 to its normal operating mode. Note that PDWN is referenced to the digital output driver supply (DRVDD) and should not exceed that supply voltage.

Low power dissipation in power-down mode is achieved by shutting down the reference, reference buffer, biasing networks, and clock. Internal capacitors are discharged when entering power-down mode and then must be recharged when returning to normal operation. As a result, wake-up time is related to the time spent in power-down mode, and shorter power-down cycles result in proportionally shorter wake-up times.

When using the SPI port interface, the user can place the ADC in power-down mode or standby mode. Standby mode allows the user to keep the internal reference circuitry powered when faster wake-up times are required. See the Memory Map section for more details.

## DIGITAL OUTPUTS

The AD9609 output drivers can be configured to interface with 1.8 V to 3.3 V CMOS logic families. Output data can also be multiplexed onto a single output bus to reduce the total number of traces required.

The CMOS output drivers are sized to provide sufficient output current to drive a wide variety of logic families. However, large drive currents tend to cause current glitches on the supplies and may affect converter performance.

Applications requiring the ADC to drive large capacitive loads or large fanouts may require external buffers or latches.

The output data format can be selected to be either offset binary or twos complement by setting the SCLK/DFS pin when operating in the external pin mode (see Table 12).

As detailed in the AN-877 Application Note, *Interfacing to High Speed ADCs via SPI*, the data format can be selected for offset binary, twos complement, or gray code when using the SPI control.

Table 12. SCLK/DFS and SDIO/PDWN Mode Selection (External Pin Mode)

| Voltage at Pin | SCLK/DFS                | SDIO/PDWN                  |
|----------------|-------------------------|----------------------------|
| AGND           | Offset binary (default) | Normal operation (default) |
| DRVDD          | Twos complement         | Outputs disabled           |

## Digital Output Enable Function (OEB)

When using the SPI interface, the data outputs and DCO can be independently three-stated by using the programmable external MODE pin. The MODE pin (OEB) function is enabled via Bits[6:5] of Register 0x08.

If the MODE pin is configured to operate in traditional OEB mode, and the MODE pin is low, the output data drivers and DCOs are enabled. If the MODE pin is high, the output data drivers and DCOs are placed in a high impedance state. This OEB function is not intended for rapid access to the data bus. Note the MODE pin is referenced to the digital output driver supply (DRVDD) and should not exceed that supply voltage.

**TIMING**

The AD9609 provides latched data with a pipeline delay of eight clock cycles. Data outputs are available one propagation delay ( $t_{PD}$ ) after the rising edge of the clock signal.

Minimize the length of the output data lines and loads placed on them to reduce transients within the AD9609. These transients can degrade converter dynamic performance.

The lowest typical conversion rate of the AD9609 is 3 MSPS. At clock rates below 3 MSPS, dynamic performance can degrade.

**Data Clock Output (DCO)**

The AD9609 provides a data clock output (DCO) signal intended for capturing the data in an external register. The CMOS data outputs are valid on the rising edge of DCO, unless the DCO clock polarity has been changed via the SPI. See Figure 2 for a graphical timing description.

**Table 13. Output Data Format**

| Input (V)   | Condition (V)     | Offset Binary Output Mode | Twos Complement Mode | OR |
|-------------|-------------------|---------------------------|----------------------|----|
| VIN+ – VIN– | < –VREF – 0.5 LSB | 00 0000 0000              | 10 0000 0000         | 1  |
| VIN+ – VIN– | = –VREF           | 00 0000 0000              | 10 0000 0000         | 0  |
| VIN+ – VIN– | = 0               | 10 0000 0000              | 00 0000 0000         | 0  |
| VIN+ – VIN– | = +VREF – 1.0 LSB | 11 1111 1111              | 01 1111 1111         | 0  |
| VIN+ – VIN– | > +VREF – 0.5 LSB | 11 1111 1111              | 01 1111 1111         | 1  |

## BUILT-IN SELF-TEST (BIST) AND OUTPUT TEST

The [AD9609](#) includes a built-in test feature designed to enable verification of the integrity of each channel as well as to facilitate board level debugging. A built-in self-test (BIST) feature that verifies the integrity of the digital datapath of the [AD9609](#) is included. Various output test options are also provided to place predictable values on the outputs of the [AD9609](#).

### BUILT-IN SELF-TEST (BIST)

The BIST is a thorough test of the digital portion of the selected [AD9609](#) signal path. Perform the BIST test after a reset to ensure that the part is in a known state. During BIST, data from an internal pseudorandom noise (PN) source is driven through the digital datapath of both channels, starting at the ADC block output. At the datapath output, CRC logic calculates a signature from the data. The BIST sequence runs for 512 cycles and then stops. Once completed, the BIST compares the signature results with a pre-determined value. If the signatures match, the BIST sets Bit 0 of Register 0x24, signifying the test passed. If the BIST test failed, Bit 0 of Register 0x24 is cleared. The outputs are connected during this test, so the PN sequence can be observed as it runs. Writing 0x05 to Register 0x0E runs the BIST. This enables the Bit 0 (BIST enable) of Register 0x0E and resets the PN sequence generator,

Bit 2 (BIST INIT) of Register 0x0E. At the completion of the BIST, Bit 0 of Register 0x24 is automatically cleared. The PN sequence can be continued from its last value by writing a 0 in Bit 2 of Register 0x0E. However, if the PN sequence is not reset, the signature calculation does not equal the predetermined value at the end of the test. At that point, the user needs to rely on verifying the output data.

### OUTPUT TEST MODES

The output test options are described in Table 17 at Address 0x0D. When an output test mode is enabled, the analog section of the ADC is disconnected from the digital back-end blocks and the test pattern is run through the output formatting block. Some of the test patterns are subject to output formatting, and some are not. The PN generators from the PN sequence tests can be reset by setting Bit 4 or Bit 5 of Register 0x0D. These tests can be performed with or without an analog signal (if present, the analog signal is ignored), but they do require an encode clock. For more information, see the [AN-877 Application Note, Interfacing to High Speed ADCs via SPI](#).