



Chipsmall Limited consists of a professional team with an average of over 10 year of expertise in the distribution of electronic components. Based in Hongkong, we have already established firm and mutual-benefit business relationships with customers from,Europe,America and south Asia,supplying obsolete and hard-to-find components to meet their specific needs.

With the principle of “Quality Parts,Customers Priority,Honest Operation,and Considerate Service”,our business mainly focus on the distribution of electronic components. Line cards we deal with include Microchip,ALPS,ROHM,Xilinx,Pulse,ON,Everlight and Freescale. Main products comprise IC,Modules,Potentiometer,IC Socket,Relay,Connector.Our parts cover such applications as commercial,industrial, and automotives areas.

We are looking forward to setting up business relationship with you and hope to provide you with the best service and solution. Let us make a better world for our industry!



## Contact us

Tel: +86-755-8981 8866 Fax: +86-755-8427 6832

Email & Skype: info@chipsmall.com Web: www.chipsmall.com

Address: A1208, Overseas Decoration Building, #122 Zhenhua RD., Futian, Shenzhen, China



## FEATURES

- Demodulates signal input bandwidths to 30 kHz
- Programmable filter enables variable bandwidths
- Filter tracks input carrier frequency
- Programmable reference clock frequency
- Flexible system interface
  - Single-ended/differential signal inputs and outputs
  - Rail-to-rail outputs directly drive analog-to-digital converters (ADCs)
- Phase detection sensitivity of  $9.3m^{\circ}\theta_{REL}$  rms
- Configurable with 3-wire and 4-wire serial port interface (SPI) or seamless boot from I<sup>2</sup>C EEPROMs
- Very low power operation
  - 395  $\mu$ A at  $f_{CLKIN} = 500$  kHz
- Single supply: 2.7 V to 3.6 V
- Specified temperature range:  $-40^{\circ}\text{C}$  to  $+85^{\circ}\text{C}$
- 16-lead TSSOP package

## APPLICATIONS

- Synchronous demodulation
- Sensor signal conditioning
- Lock-in amplifiers
- Phase detectors
- Precision tunable filters
- Signal recovery
- Control systems

## GENERAL DESCRIPTION

The ADA2200 is a sampled analog technology<sup>1</sup> synchronous demodulator for signal conditioning in industrial, medical, and communications applications. The ADA2200 is an analog input, sampled analog output device. The signal processing is performed entirely in the analog domain by charge sharing among capacitors, which eliminates the effects of quantization noise and rounding errors. The ADA2200 includes an analog domain, low-pass decimation filter, a programmable infinite impulse response (IIR) filter, and a mixer. This combination of features reduces ADC sample rates and lowers the downstream digital signal processing requirements.

The ADA2200 acts as a precision filter when the demodulation function is disabled. The filter has a programmable bandwidth and tunable center frequency. The filter characteristics are highly stable over temperature, supply, and process variation.

Single-ended and differential signal interfaces are possible on both input and output terminals, simplifying the connection to other

<sup>1</sup> Patent pending.

Rev. 0

[Document Feedback](#)

Information furnished by Analog Devices is believed to be accurate and reliable. However, no responsibility is assumed by Analog Devices for its use, nor for any infringements of patents or other rights of third parties that may result from its use. Specifications subject to change without notice. No license is granted by implication or otherwise under any patent or patent rights of Analog Devices. Trademarks and registered trademarks are the property of their respective owners.

## FUNCTIONAL BLOCK DIAGRAM

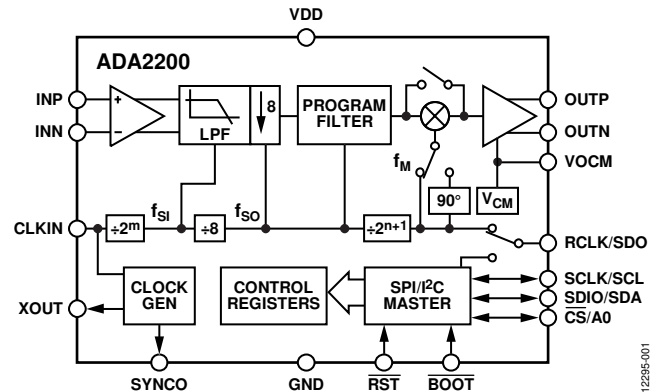

Figure 1.

12295-001

components of the signal chain. The low power consumption and rail-to-rail operation is ideal for battery-powered and low voltage systems.

The ADA2200 can be programmed over its SPI-compatible serial port or can automatically boot from the EEPROM through its I<sup>2</sup>C interface. On-chip clock generation produces a mixing signal with a programmable frequency and phase. In addition, the ADA2200 synchronization output signal eases interfacing to other sampled systems, such as data converters and multiplexers.

The ADA2200 is available in a 16-lead TSSOP package. Its performance is specified over the industrial temperature range of  $-40^{\circ}\text{C}$  to  $+85^{\circ}\text{C}$ . Note that throughout this data sheet, multifunction pins, such as SCLK/SCL, are referred to either by the entire pin name or by a single function of the pin, for example, SCLK, when only that function is relevant.

# ADA2200\* PRODUCT PAGE QUICK LINKS

Last Content Update: 02/23/2017

---

## COMPARABLE PARTS

View a parametric search of comparable parts.

## EVALUATION KITS

- ADA2200 Evaluation Board

## DOCUMENTATION

### Data Sheet

- ADA2200: Synchronous Demodulator and Configurable Analog Filter Data Sheet

### User Guides

- UG-702: Evaluation Board for the ADA2200 Synchronous Demodulator
- UG-787: Software Programmable Evaluation Board for the ADA2200 Synchronous Demodulator

## TOOLS AND SIMULATIONS

- ADA2200 SPICE Macro Model

## REFERENCE DESIGNS

- CN0371

## REFERENCE MATERIALS

### Technical Articles

- MS-2698: Use Synchronous Detection to Make Precision, Low Level Measurements

### Tutorials

- MT-234: Using the ADA2200 as a Time Domain Filter

## DESIGN RESOURCES

- ADA2200 Material Declaration
- PCN-PDN Information
- Quality And Reliability
- Symbols and Footprints

## DISCUSSIONS

View all ADA2200 EngineerZone Discussions.

## SAMPLE AND BUY

Visit the product page to see pricing options.

## TECHNICAL SUPPORT

Submit a technical question or find your regional support number.

## DOCUMENT FEEDBACK

Submit feedback for this data sheet.

---

**TABLE OF CONTENTS**

Features .....	1	Input and Output Amplifiers .....	15
Applications .....	1	Applications Information .....	16
Functional Block Diagram .....	1	Amplitude Measurements .....	16
General Description .....	1	Phase Measurements .....	16
Revision History .....	2	Amplitude and Phase Measurements .....	16
Specifications .....	3	Analog Output Systems .....	17
SPI Timing Characteristics .....	4	Interfacing to ADCs .....	17
Absolute Maximum Ratings .....	7	Lock-In Amplifier Application .....	17
Thermal Resistance .....	7	Interfacing to Microcontrollers .....	18
ESD Caution .....	7	EEPROM Boot Configuration .....	18
Pin Configuration and Function Descriptions .....	8	Power Dissipation .....	18
Typical Performance Characteristics .....	9	Device Configuration .....	19
Terminology .....	10	Serial Port Operation .....	19
Theory of Operation .....	11	Data Format .....	19
Synchronous Demodulation Basics .....	11	Serial Port Pin Descriptions .....	19
ADA2200 Architecture .....	12	Serial Port Options .....	19
Decimation Filter .....	12	Bootting from EEPROM .....	20
IIR Filter .....	13	Device Configuration Register Map and Descriptions .....	21
Mixer .....	13	Outline Dimensions .....	24
Clocking Options .....	14	Ordering Guide .....	24

**REVISION HISTORY**

**8/14—Revision 0: Initial Version**



## SPECIFICATIONS

$V_{DD} = 3.3\text{ V}$ ,  $V_{OCM} = V_{DD}/2$ ,  $f_{CLKIN} = f_{SI} = 500\text{ kHz}$ , default register configuration, differential input/output,  $R_L = 1\text{ M}\Omega$  to GND,  $T_A = 25^\circ\text{C}$ , unless otherwise noted.

Table 1.

Parameter	Test Conditions/Comments	Min	Typ	Max	Unit
<b>SYNCHRONOUS DEMODULATION</b>					
	Measurements are cycle mean values, <sup>1</sup> 4 V p-p differential, $f_{IN} = 7.8125\text{ kHz}$				
Conversion Gain <sup>1</sup>		1.02	1.055	1.09	V/V rms
Average Temperature Drift			5		ppm/ $^\circ\text{C}$
Output Offset, Shorted Inputs		-39		+39	mV
Average Temperature Drift			6.5		$\mu\text{V}/^\circ\text{C}$
Power Supply Sensitivity	Change in output over change in $V_{DD}$		0.5		mV/V
Measurement Noise	Input signal at $83^\circ\theta_{REL}$ <sup>1</sup>		240		$\mu\text{V rms}$
Phase Delay ( $^\circ\theta_{DELAY}$ ) <sup>1</sup>	Input signal relative to RCLK		83		$^\circ\theta_{REL}$
Average Temperature Drift			70		$\mu^\circ\theta_{REL}/^\circ\text{C}$
Phase Measurement Noise	Input signal at $83^\circ\theta_{REL}$		9.3		$m^\circ\theta_{REL rms}$
Shorted Input Noise	0.1 Hz to 10 Hz		300		$\mu\text{V p-p}$
Common-Mode Rejection <sup>2</sup>	0 kHz to 1 kHz offset from $f_{MOD}$		75		dB
Demodulation Signal Bandwidth	$f_{CLKIN} = 1\text{ MHz}$		30		kHz
<b>INPUT CHARACTERISTICS</b>					
Input Voltage Range	INP or INN to GND	0.3		$V_{DD} - 0.3$	V
Common-Mode Input Voltage Range	4 V p-p differential input	$V_{OCM} - 0.2$		$V_{OCM} + 0.2$	V
Single-Ended Input Voltage Range					
Reference Input		$V_{OCM} - 0.2$		$V_{OCM} + 0.2$	V
Signal Input		$V_{OCM} - 1.0$		$V_{OCM} + 1.0$	V
Input Impedance <sup>3</sup>	INP to INN		80		k $\Omega$
Input Signal Bandwidth (-3 dB)	Input sample and hold circuit		4		MHz
<b>OUTPUT CHARACTERISTICS</b>					
	Each output, $R_L = 10\text{ k}\Omega$ to GND				
Output Voltage Range		0.3		$V_{DD} - 0.3$	V
Short-Circuit Current	OUTP or OUTN to GND		15		mA
Common-Mode Output (VOCM)					
Voltage		1.63	1.65	1.67	V
Average Temperature Drift			9		$\mu\text{V}/^\circ\text{C}$
Output Settling Time, to 0.1% of Final Value	3.7 V output step, $R_{LOAD} = 10\text{ k}\Omega  10\text{ pF}$ , $f_{CLKIN} = 125\text{ kHz}$		15		$\mu\text{s}$
<b>DEFAULT FILTER CHARACTERISTICS</b>					
	Mixing disabled, $V_{IN} = 4\text{ V p-p differential}$				
Center Frequency ( $f_C$ )	$f_C = f_{SO}/8$		7.8125		kHz
Quality Factor (Q)	$f_C/(\text{filter } 3\text{ dB bandwidth})$		1.9		Hz/ $\Delta\text{Hz}$
Pass Band Gain	$f_{IN} = 7.8125\text{ kHz}$		1.05		V/V
<b>TOTAL HARMONIC DISTORTION (THD)</b>					
	Filter configuration = LPF at $f_{NYQ}/6$ , $f_{IN} = 850\text{ Hz}$ , $V_{IN} = 4\text{ V p-p differential input}$				
Second Through Fifth Harmonics			-80		dBc
<b>CLOCKING CHARACTERISTICS</b>					
	$T_A = -40^\circ\text{C to } +85^\circ\text{C}$				
CLKIN Frequency Range ( $f_{CLKIN}$ )	CLKIN DIV[2:0] = 256	2.56		20	MHz
	CLKIN DIV[2:0] = 64	0.64		20	MHz
	CLKIN DIV[2:0] = 16	0.16		16	MHz
	CLKIN DIV[2:0] = 1	0.01		1	MHz
Maximum CLKIN Frequency	While booting from EEPROM			12.8	MHz

Parameter	Test Conditions/Comments	Min	Typ	Max	Unit
<b>DIGITAL I/O</b>					
Logic Thresholds	All inputs/outputs				
Input Voltage					
Low				0.8	V
High		2.0			V
Output Voltage					
Low	While sinking 200 $\mu$ A			0.4	V
High	While sourcing 200 $\mu$ A	$V_{DD} - 0.4$			V
Maximum Output Current	Sink or source			8	mA
Input Leakage				1	$\mu$ A
Internal Pull-Up Resistance	$\overline{BOOT}$ and $\overline{RST}$ only		40		k $\Omega$
<b>CRYSTAL OSCILLATOR</b>					
Internal Feedback Resistor			500		k $\Omega$
CLKIN Capacitance			2		pF
XOUT Capacitance			2		pF
<b>POWER REQUIREMENTS</b>					
Power Supply Voltage Range		2.7		3.6	V
Total Supply Current Consumption			395	485	$\mu$ A

<sup>1</sup> See the Terminology section.

<sup>2</sup> Common-mode signal swept from  $f_{MOD} - 1$  kHz to  $f_{MOD} + 1$  kHz. Output measured at frequency offset from  $f_{MOD}$ . For example, a common-mode signal at  $f_{MOD} - 500$  Hz is measured at 500 Hz.

<sup>3</sup> The input impedance is equal to a 4 pF capacitor switched at  $f_{CLKIN}$ . Therefore, the input impedance =  $10^{12}/(2\pi f_{CLKIN} \times 4)$ .

## SPI TIMING CHARACTERISTICS

$V_{DD} = 2.7$  V to 3.6 V, default register configuration,  $T_A = -40$  to  $+85^\circ\text{C}$ , unless otherwise noted.

Table 2. SPI Timing

Parameter	Test Conditions/Comments	Min	Typ	Max	Unit
$f_{SCLK}$	50% $\pm$ 5% duty cycle			20	MHz
$t_{\overline{CS}}$	$\overline{CS}$ to SCLK edge	2			ns
$t_{SL}$	SCLK low pulse width	10			ns
$t_{SH}$	SCLK high pulse width	10			ns
$t_{DAV}$	Data output valid after SCLK edge			20	ns
$t_{DSU}$	Data input setup time before SCLK edge	2			ns
$t_{DHD}$	Data input hold time after SCLK edge	2			ns
$t_{DF}$	Data output fall time			1	ns
$t_{DR}$	Data output rise time			1	ns
$t_{SR}$	SCLK rise time			10	ns
$t_{SF}$	SCLK fall time			10	ns
$t_{DOCS}$	Data output valid after $\overline{CS}$ edge			1	ns
$t_{SFS}$	$\overline{CS}$ high after SCLK edge	2			ns

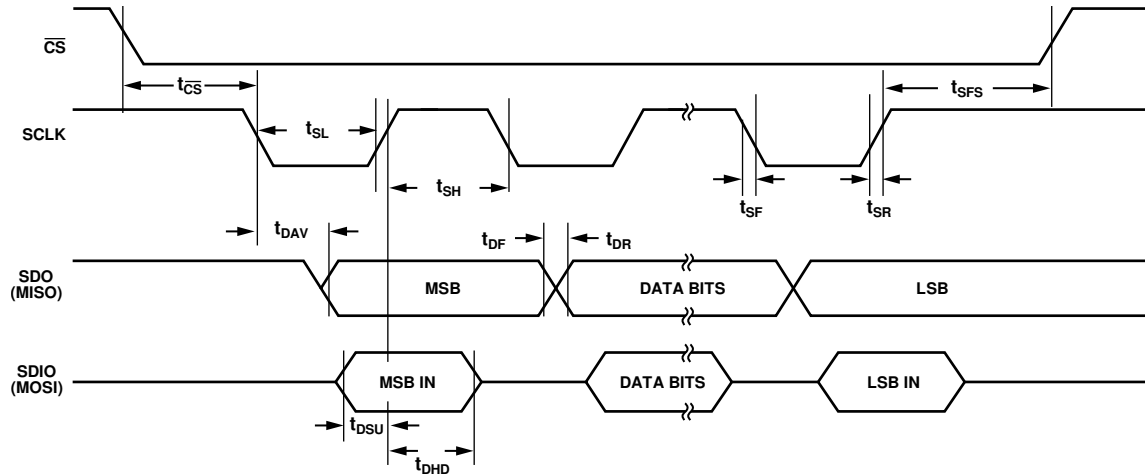

Figure 2. SPI Read Timing Diagram (SPI Master Read from the ADA2200)

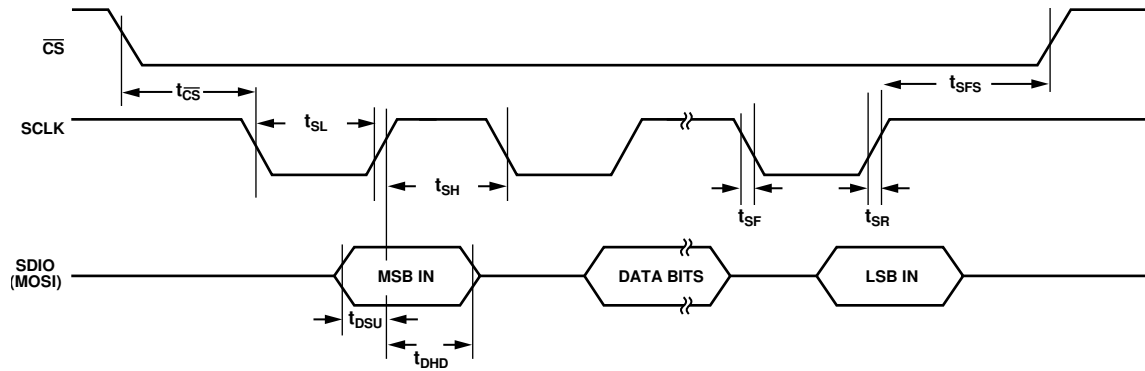

Figure 3. SPI Write Timing Diagram (SPI Master Write to the ADA2200)

Table 3. EEPROM Master I<sup>2</sup>C Boot Timing

Parameter <sup>1</sup>	Symbol	Min	Typical	Max	Unit
BOOT					
Load from $\overline{\text{BOOT}}$ Complete				9600	CLKIN cycles
$\overline{\text{RST}}$ to $\overline{\text{BOOT}}$ Setup Time	$t_2$			2	CLKIN cycles
$\overline{\text{BOOT}}$ Pulse Width	$t_3$			1	CLKIN cycles
RESET					
Minimum $\overline{\text{RST}}$ Pulse Width	$t_1$	25			ns
START CONDITION					
$\overline{\text{BOOT}}$ Low Transition to Start Condition	$t_4$			3	CLKIN cycles

<sup>1</sup> CLKIN cycles with CLKIN DIV[2:0] set to 000.

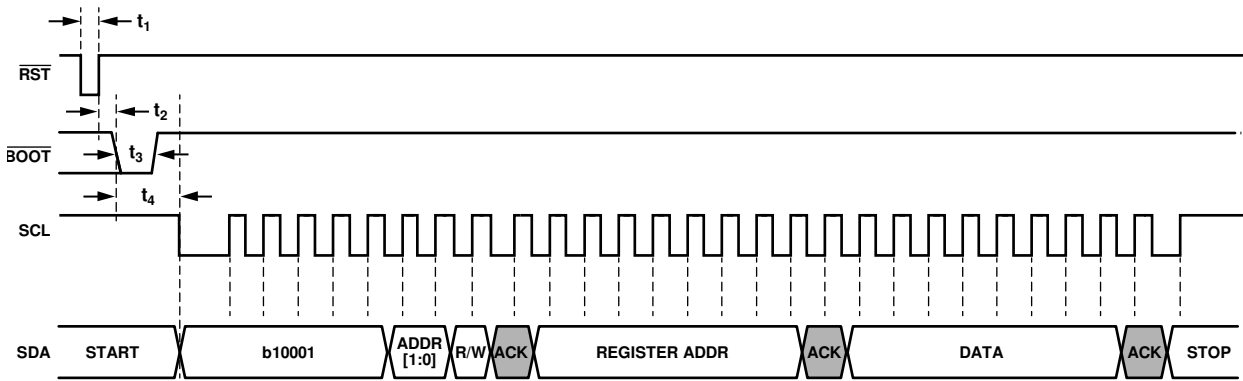

Figure 4. Load from EEPROM Timing Diagram

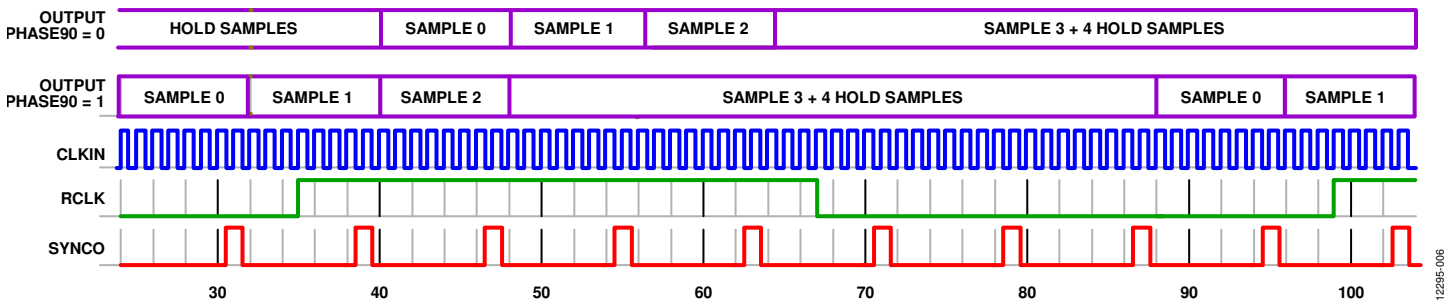

Figure 5. CLKIN to RCLK, SYNCO, and OUTP/OUTN Sample Timing

Table 4. Output, SYNCO, and RCLK Timing, Default Register Settings

Parameter	Test Conditions/Comments	Min	Typ	Max	Unit
$t_1$	CLKIN to OUTx sample update delay		50		ns
$t_2$	CLKIN to SYNCO delay, rising or falling edge to rising edge			40	ns
$t_3$	SYNCO pulse width		$1/f_{SI}$		ns
$t_4$	CLKIN to RCLK delay, rising edge to rising or falling edge			70	ns

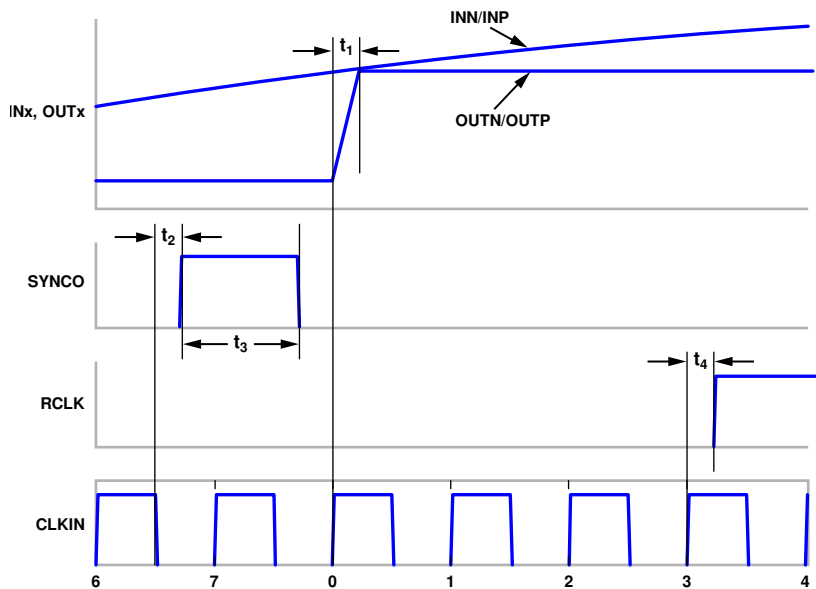

Figure 6. Input, Output, SYNCO, and RCLK Timing Relative to CLKIN



## ABSOLUTE MAXIMUM RATINGS

Table 5.

Parameter	Rating
Supply Voltage	3.9 V
Output Short-Circuit Current Duration	Indefinite
Maximum Voltage at Any Input	$V_{DD} + 0.3 \text{ V}$
Minimum Voltage at Any Input	$\text{GND} - 0.3 \text{ V}$
Operational Temperature Range	$-40^{\circ}\text{C}$ to $+125^{\circ}\text{C}$
Storage Temperature Range	$-65^{\circ}\text{C}$ to $+150^{\circ}\text{C}$
Package Glass Transition Temperature	$150^{\circ}\text{C}$
ESD Ratings	
Human Body Model (HBM)	1000 V
Device Model (FICDM)	500 V
Machine Model (MM)	50 V

Stresses at or above those listed under Absolute Maximum Ratings may cause permanent damage to the product. This is a stress rating only; functional operation of the product at these or any other conditions above those indicated in the operational section of this specification is not implied. Operation beyond the maximum operating conditions for extended periods may affect product reliability.

## THERMAL RESISTANCE

$\theta_{JA}$  is specified for a device in a natural convection environment, soldered on a 4-layer JEDEC printed circuit board (PCB).

Table 6.

Package	$\theta_{JA}$	$\theta_{JC}$	Unit
16-Lead TSSOP	100	14.8	$^{\circ}\text{C}/\text{W}$

## ESD CAUTION



**ESD (electrostatic discharge) sensitive device.** Charged devices and circuit boards can discharge without detection. Although this product features patented or proprietary protection circuitry, damage may occur on devices subjected to high energy ESD. Therefore, proper ESD precautions should be taken to avoid performance degradation or loss of functionality.

## PIN CONFIGURATION AND FUNCTION DESCRIPTIONS

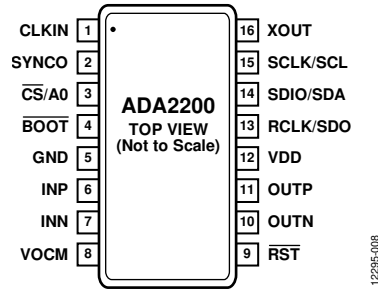

Figure 7. Pin Configuration

12295-008

Table 7. Pin Function Descriptions

Pin No.	Mnemonic	Description
1	CLKIN	System Clock Input.
2	SYNCO	Synchronization Signal Output.
3	$\overline{\text{CS/A0}}$	Serial Interface Chip Select Input/Boot EEPROM Address 0 Input.
4	$\overline{\text{BOOT}}$	Boot from EEPROM Control Input.
5	GND	Power Supply Ground.
6	INP	Noninverting Signal Input.
7	INN	Inverting Signal Input.
8	VOCM	Common-Mode Voltage Output.
9	$\overline{\text{RST}}$	Reset Control Input.
10	OUTN	Inverting Output.
11	OUTP	Noninverting Output.
12	VDD	Positive Supply Input.
13	RCLK/SDO	Reference Clock Output/Serial Interface Data Output (in 4-Wire SPI Mode).
14	SDIO/SDA	Bidirectional Serial Data (Input Only in 4-Wire SPI Mode)/I <sup>2</sup> C Bidirectional Data.
15	SCLK/SCL	Serial Interface Clock Input/I <sup>2</sup> C Clock Output.
16	XOUT	Crystal Driver Output. Place a crystal between this pin and CLKIN, or leave this pin disconnected.

# TYPICAL PERFORMANCE CHARACTERISTICS

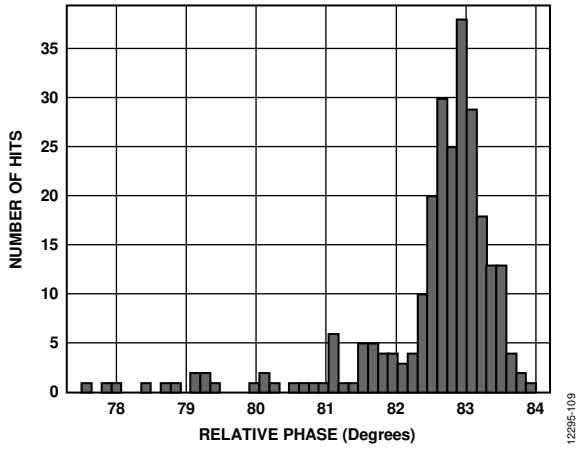

Figure 8. Histogram of Device-to-Device Phase Delay Variation

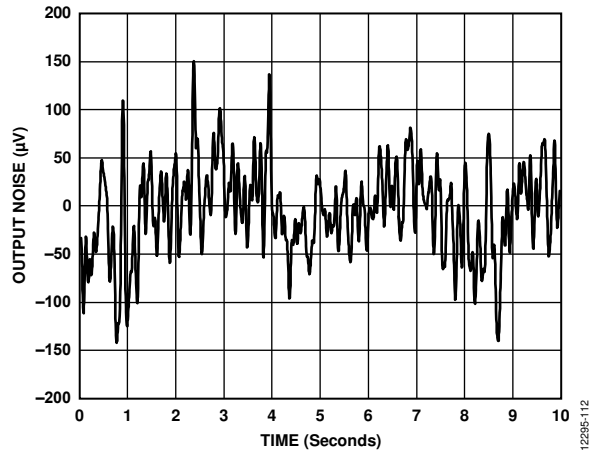

Figure 11. 0.1 Hz to 10 Hz Output Noise, Shorted Inputs

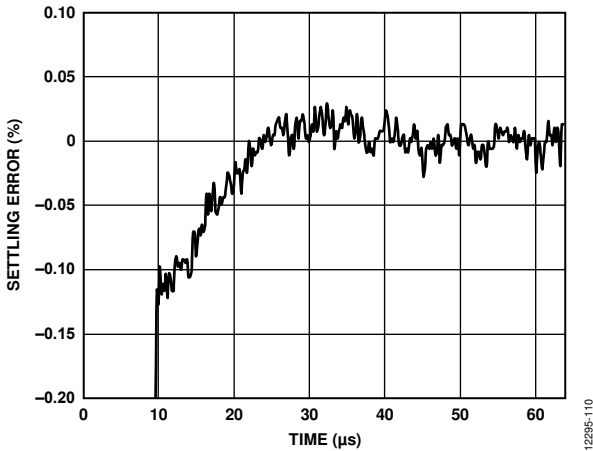

Figure 9. Output Settling from SYNC0 Falling Edge, 3.7V Steps

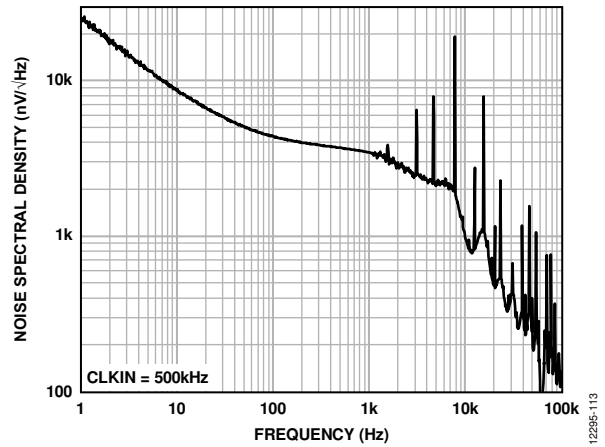

Figure 12. Noise Spectral Density vs. Frequency,  $f_{CLKIN} = 500 \text{ kHz}$

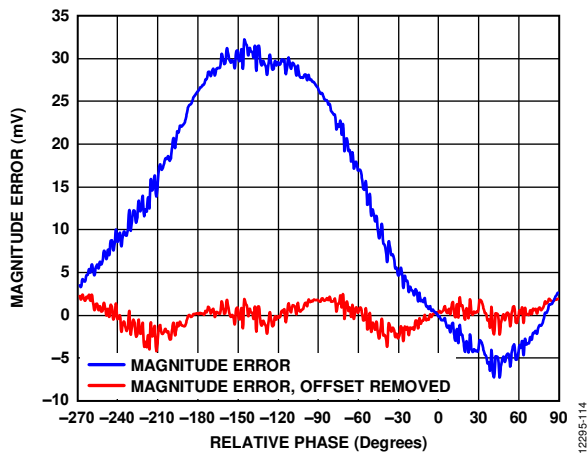

Figure 10. Magnitude Measurement Error vs. Relative Phase

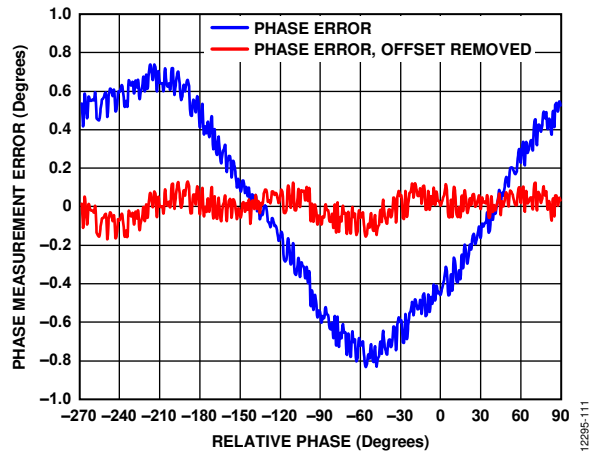

Figure 13. Phase Measurement Error vs. Relative Phase

## TERMINOLOGY

### Cycle Mean

The cycle mean is the average of all the output samples (OUTP/OUTN) over one RCLK period. In the default configuration, there are eight output samples per RCLK cycle; thus, the cycle mean is the average of eight consecutive output samples. If the device is reconfigured such that the frequency of RCLK is  $f_{SO}/4$ , then the cycle mean is the average of four consecutive output samples.

### Conversion Gain

Conversion gain is calculated as follows:

$$\text{Conversion Gain} = \frac{\sqrt{I^2 + Q^2}}{V_{IN}}$$

where:

$I$  is the offset corrected cycle mean, PHASE90 bit = 0.

$Q$  is the offset corrected cycle mean, PHASE90 bit = 1.

$V_{IN}$  is the rms value of the input voltage.

The offset corrected cycle mean = cycle mean – output offset.

### Relative Phase ( $\theta_{REL}$ )

Relative phase is the phase difference between the rising positive zero crossing of a sine wave at the INN/INP inputs relative to the next rising edge of RCLK.

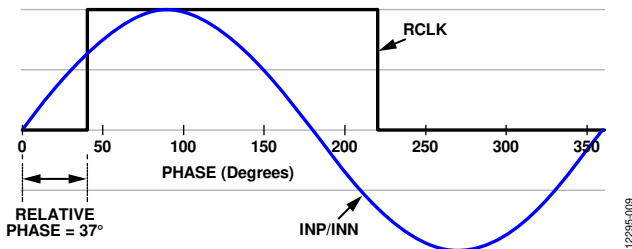

Figure 14. Example Showing Relative Phase,  $\theta_{REL}$ , of 37°

### Phase Delay ( $\theta_{DELAY}$ )

The phase delay is the relative phase ( $\theta_{REL}$ ) that produces a zero cycle mean output value for a sine wave input with a frequency equal to  $f_{RCLK}$ . The phase delay is the relative phase value that corresponds to the positive zero crossing of the phase measurement transfer function.

### Phase Measurement Transfer Function

Figure 15 shows the cycle mean value of the output for a 1 V rms input sine wave as  $\theta_{REL}$  is swept from 0° to 360°.

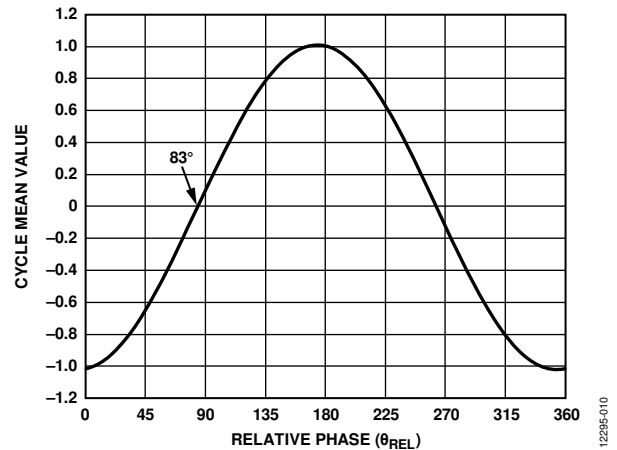

Figure 15. Phase Transfer Function with Phase Delay of 83°, 1 V rms Input

## THEORY OF OPERATION

The ADA2200 is a synchronous demodulator and tunable filter implemented with sampled analog technology (SAT). Synchronous demodulators, also known as lock-in amplifiers, enable accurate measurement of small ac signals in the presence of noise interference orders of magnitude greater than the signal amplitude. Synchronous demodulators use phase sensitive detection to isolate the component of the signal at a specific reference frequency and phase. Noise at frequencies that are offset from the reference frequency are easily rejected and do not significantly impair the measurement.

SAT works on the principle of charge sharing. A sampled analog signal is a stepwise continuous signal without amplitude quantization. This contrasts with a signal sampled by an ADC, which becomes a discrete time signal with quantized amplitude.

With SAT, the input signal is sampled by holding the voltage on a capacitor at the sampling instant. Basic signal processing can then be performed in the analog domain by charge sharing among capacitors. The ADA2200 includes an analog domain low-pass decimation filter, a programmable IIR filter, and a mixer. This combination of features enables reduced ADC sample rates and lowers the downstream digital signal processing requirements if the signal is digitized.

The output of the ADA2200 can also be used in an all analog signal path. In these applications, add a reconstruction filter following the ADA2200 in the signal path.

### SYNCHRONOUS DEMODULATION BASICS

Employing synchronous demodulation as a sensor signaling conditioning technique can result in improved sensitivity when compared to other methods. Synchronous demodulation adds two key benefits for recovering small sensor output signals in the presence of noise. The first benefit being the addition of an excitation signal, which enables the sensor output signal to be moved to a lower noise frequency band. The second benefit is that synchronous demodulation enables a simple low-pass filter to remove most of the remaining undesired noise components.

Figure 16 shows a basic synchronous demodulation system used for measuring the output of a sensor.

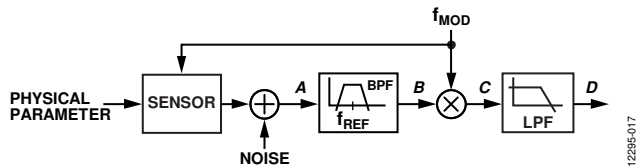

Figure 16. Basic Synchronous Demodulator Block Diagram

A carrier signal ( $f_{MOD}$ ) excites the sensor. This shifts the signal generated by the physical parameter being measured by the sensor to the carrier frequency. This shift allows the desired signal to be placed in a frequency band with lower noise, improving the accuracy of the measurement. A band-pass filter (BPF) removes some of the out of band noise. A synchronous demodulator (or mixer) shifts the signal frequency back to dc. The last stage low-pass filter removes much of the remaining noise. Figure 17 and Figure 18 show the frequency spectrum of the signal at different points in the synchronous demodulator.

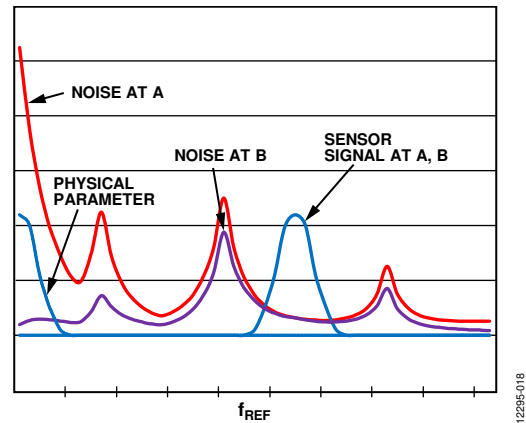

Figure 17. Output Spectrum of Synchronous Demodulator Before Demodulation

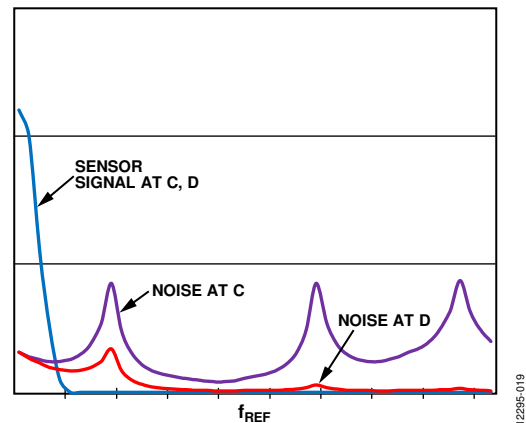

Figure 18. Output Spectrum of Synchronous Demodulator After Demodulation

### Phase Sensitive Detection

Synchronous demodulation uses the principle of phase sensitive detection to separate the signal of interest from unwanted signals. In Figure 16, the mixer performs the phase sensitive detection. The signal at the mixer output (C) is the product of the reference signal and a filtered version of the sensor output (B). If the reference signal is a sine wave, the physical parameter is a constant and there is no noise in the system. The signal at the output of the BPF is a sine wave that can be expressed as

$$V_B \sin(\omega_{REF}t + \phi_B)$$

The output of the mixer (if implemented as a multiplier) is then

$$\frac{1}{2} V_B V_{REF} \cos(\phi_B - \phi_{REF}) - \frac{1}{2} V_B V_{REF} \cos(2\omega_{REF} t + \phi_B + \phi_{REF})$$

This signal is a dc signal and an ac signal at twice the reference frequency. If the LPF is sufficient to remove the ac signal, the signal at the LPF output (D) is

$$\frac{1}{2} V_B V_{REF} \cos(\phi_B - \phi_{REF})$$

The LPF output is a dc signal that is proportional to both the magnitude and phase of the signal at the BPF output (B). When the input amplitude is held constant, the LPF output enables can be used to measure the phase. When the input phase is held constant, the LPF can be used to measure amplitude.

Note that the reference signal is not required to be a pure sine wave. The excitation signal and demodulation signal must only share a common frequency and phase to employ phase sensitive detection. In some applications, it may be possible to use the square wave output from the ADA2200 RCLK output directly.

Internal to the ADA2200, the demodulation is performed not by multiplying the REFCLK signal with the input signal, but by holding the output constant for 1/2 the sample output periods. This operation is similar to a half wave demodulation of the input signal. For more information on signal detection using this function, see the Applications Information section.

**ADA2200 ARCHITECTURE**

The signal path for the ADA2200 consists of a high impedance input buffer followed by a fixed low-pass filter (FIR decimation filter), a programmable IIR filter, a mixer function, and a differential pin driver. Figure 19 shows a detailed block diagram of the ADA2200. The signal processing blocks are all implemented using a charge sharing technique.

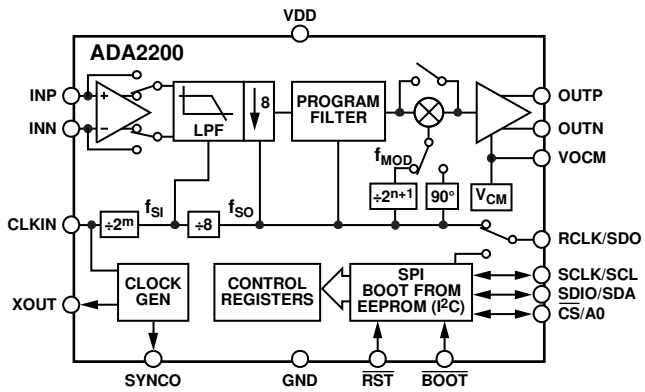

Figure 19. ADA2200 Architecture

**DECIMATION FILTER**

The clock signal divider (after CLKIN) determines the input sampling frequency,  $f_{SI}$ , of the decimation filter. The decimation filter produces one filtered sample for every eight input samples. Figure 20 shows the wideband frequency response of the decimation filter. Because the filter operates on sampled data, images of the filter appear at multiples of the input sample rate,  $f_{SI}$ . The stop band of the decimation filter begins around 1/2 of the output data rate,  $f_{SO}$ . Because an image pass band exists around  $f_{SI}$ , any undesired signals in the pass band around  $f_{SI}$  alias to dc and are indistinguishable from the low frequency input signal.

To preserve the full dynamic range of the ADA2200, use an input antialiasing filter if noise at frequencies above  $7.5 f_{SI}$  is not lower than the noise floor of the frequencies of interest. A first-order low-pass filter is usually sufficient for the antialiasing filter.

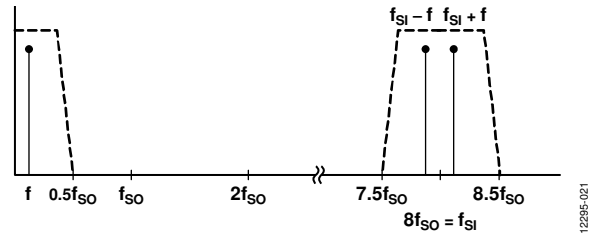

Figure 20. Decimation Filter Frequency Response

Figure 21 shows a more narrow bandwidth view of the decimation transfer function. The stop band of the decimation filter starts at 1/2 of the output sample rate. The stop band rejection of the decimator low-pass filter is approximately 55 dB. The pass band of the decimation filter extends to 1/4<sup>th</sup> of the output sample rate or 1/32<sup>nd</sup> of the decimator input sample rate.

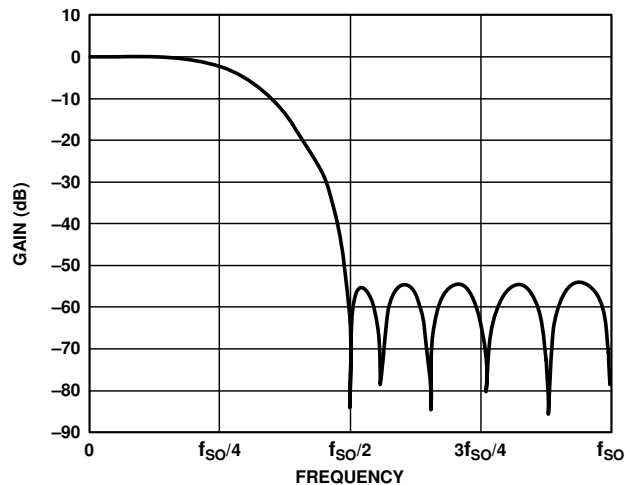

Figure 21. Decimation Filter Transfer Function,  $f_{SI} = 800$  kHz



## IIR FILTER

The IIR block operates at the output sample rate,  $f_{so}$ , which is at  $1/8^{\text{th}}$  of the input sample rate ( $f_{si}$ ). By default, the IIR filter is configured as a band-pass filter with a center frequency at  $f_{so}/8$  ( $f_{si}/64$ ). This frequency corresponds to the default mixing frequency and assures that input signals in the center of the pass band mix down to dc.

Figure 22 shows the default frequency response of the IIR filter.

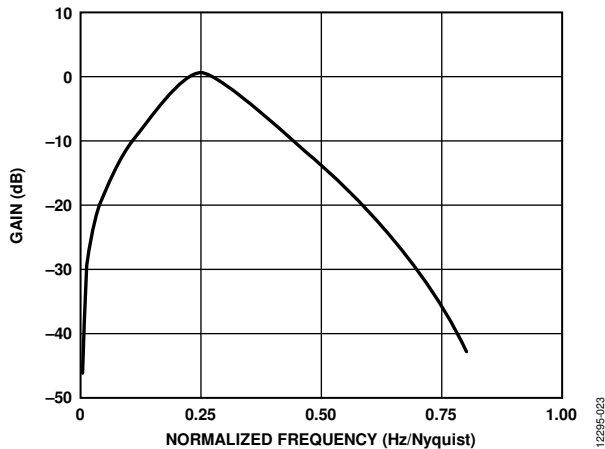

Figure 22. Default IIR Filter Frequency Response ( $f_{so}/8$  BPF)

If a different frequency response is required, the IIR can be programmed for a different response. Register 0x0011 through Register 0x0027 contain coefficient values that program the filter response. To program the filter, first load the configuration registers (Register 0x0011 through Register 0x0027) with the desired coefficients. The coefficients can then be loaded into the filter by writing 0x03 to Register 0x0010.

The IIR filter can be configured for all pass operation by loading the coefficients listed in Table 8.

Table 8. IIR Coefficients for the All Pass Filter

Register	Value
0x0011	0xC0
0x0012	0x0F
0x0013	0x1D
0x0014	0xD7
0x0015	0xC0
0x0016	0x0F
0x0017	0xC0
0x0018	0x0F
0x0019	0x1D
0x001A	0x97
0x001B	0x7E
0x001C	0x88
0x001D	0xC0
0x001E	0x0F
0x001F	0xC0
0x0020	0x0F
0x0021	0xC0
0x0022	0x0F
0x0023	0x00
0x0024	0x0E
0x0025	0x23
0x0026	0x02
0x0027	0x24

## MIXER

The ADA2200 performs the mixing function by holding the output samples constant for  $1/2$  of the RCLK period. This is similar to a half-wave rectification function except that the output does not return to zero for  $1/2$  the output period, but retains the value of the previous sample.

In the default configuration, there are eight output sample periods during each RCLK cycle. There are four updated output samples while the RCLK signal is high. While RCLK is low, the fourth updated sample is held constant for four additional output sample periods. The timing of the output samples in the default configuration is shown in Table 4.

The RCLK divider, RCLK DIV[1:0], can be set to divide  $f_{so}$  by 4. When this mode is selected, four output sample periods occur during each RCLK cycle. Two output samples occur while the RCLK signal is high. While RCLK is low, the second updated sample is held constant for two additional output sample periods.

The mixer can be bypassed. When the mixer is bypassed, the output produces an updated sample value every output sample period.

**Phase Shifter**

It is possible to change the timing of the output samples with respect to RCLK by writing to the PHASE90 bit in Register 0x002A. When the alternative timing option is selected, two output samples are updated while RCLK is low, and two are updated while RCLK is high. The second sample, which is taken while RCLK is high, is held four additional output sample periods. The timing is shown in Figure 5.

Applying a 90° phase shift can be useful in a number of instances. It enables a pair of ADA2200 devices to perform in phase and quadrature demodulation. A 90° phase shift can also be useful in control systems for selecting an appropriate error signal output.

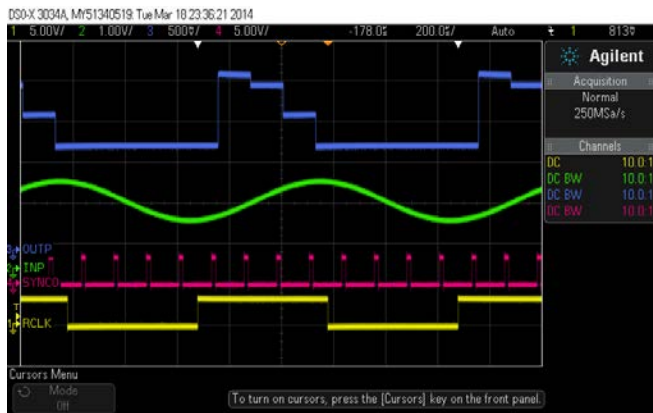

(A)

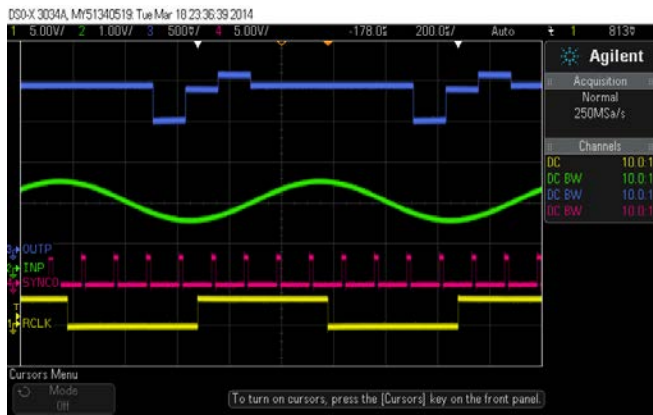

(B)

Figure 23. Output Sample Timing Relative to RCLK, (A) PHASE90 = 0, (B) PHASE90 = 1

**CLOCKING OPTIONS**

The ADA2200 has several clocking options to make system integration easier.

**Clock Dividers**

The ADA2200 has a pair of on-chip clock dividers to generate the system clocks. The input clock divider, CLKIN DIV[2:0], sets the input sample rate of the decimator ( $f_{SI}$ ) by dividing the CLKIN signal. The value of CLKIN DIV[2:0] can be set to 1, 16, 64, or 256.

The output sample rate ( $f_{SO}$ ) is always  $1/8^{th}$  of the decimator input sample rate.

The RCLK divider, RCLK DIV[1:0], sets the frequency of the mixer frequency,  $f_M$  (which is also the frequency of RCLK) by dividing  $f_{SO}$  by either 4 or 8.

**Synchronization Pulse Output**

The ADA2200 generates an output pulse (SYNCO), which can be used by a microprocessor or directly by an ADC to initiate an analog to digital conversion of the ADA2200 output. The SYNCO signal ensures that the ADC sampling occurs at an optimal time during the ADA2200 output sample window.

One output sample of the ADA2200 is  $8 f_{SI}$  clock cycles long. The SYNCO pulse is  $1 f_{SI}$  clock cycle in duration. As shown in Figure 24, the SYNCO pulse can be programmed to occur at 1 of 16 different timing offsets. The timing offsets are spaced at  $1/2 f_{SI}$  clock cycle intervals and span the full output sample window.

The SYNCO pulse can be inverted, or the SYNCO output can be disabled. The operation of the SYNCO timing generation configuration settings are contained in Register 0x0029.

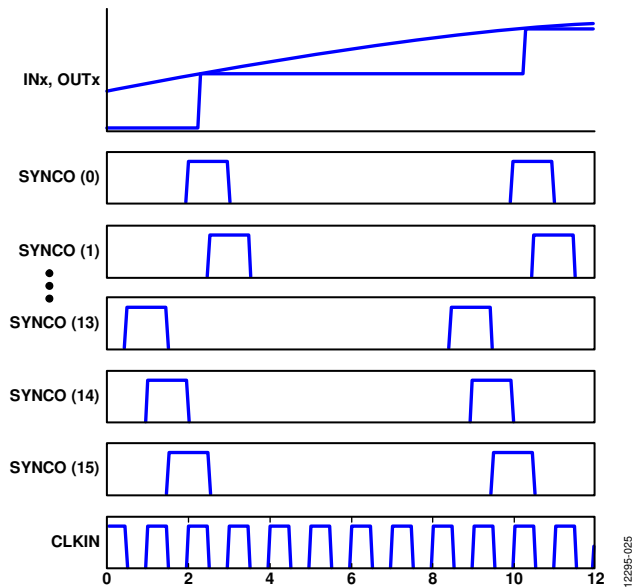

Figure 24. SYNCO Output Timing Relative to OUTP/OUTN, INP/INN, and CLKIN

**INPUT AND OUTPUT AMPLIFIERS*****Single-Ended Configurations***

If a single-ended input configuration is desired, the input signal must have a common-mode voltage near midsupply. Decouple the other inputs to the common-mode voltage of the input signal.

Note that differences between the common-mode levels between the INP and INN inputs result in an offset voltage inside the device. Even though the BPF removes the offset, minimize the offset to avoid reducing the available signal swing internal to the device.

For single-ended outputs, either OUTP or OUTN can be used. Leave the unused output floating.

***Differential Configurations***

Using the [ADA2200](#) in differential mode utilizes the full dynamic range of the device and provides the best noise performance and common-mode rejection.

## APPLICATIONS INFORMATION

The signal present at the output of the ADA2200 depends on the amplitude and relative phase of the signal applied at its inputs. When the amplitude or phase is known and constant, any output variations can be attributed to the modulated parameter. Therefore, when the relative phase of the input is constant, the ADA2200 performs amplitude demodulation. When the amplitude is constant, the ADA2200 performs phase demodulation.

The sampling and demodulation processes introduce additional frequency components onto the output signal. If the output signal of the ADA2200 is used in the analog domain or if it is sampled asynchronously to the ADA2200 sample clock, these high frequency components can be removed by following the ADA2200 with a reconstruction filter.

If the ADA2200 output is sampled synchronously to the ADA2200 output sample rate, an analog reconstruction filter is not required because the ADC inherently rejects sampling artifacts. The frequency artifacts introduced by the demodulation process can be removed by digital filtering.

### AMPLITUDE MEASUREMENTS

If the relative phase of the input signal to the ADA2200 remains constant, the output amplitude is directly proportional to the amplitude of the input signal. Note that the signal gain is a function of the relative phase of the input signal. Figure 15 shows the relationship between the cycle mean output and the relative phase. The cycle mean output voltage is

$$V_{\text{CYCLEMEAN}} = \text{Conversion Gain} \times V_{\text{IN(RMS)}} \times \sin(\theta_{\text{REL}} - \theta_{\text{DEL}}) = 1.05 \times V_{\text{IN(RMS)}} \times \sin(\theta_{\text{REL}} - \theta_{\text{DEL}})$$

Therefore, the highest gain, and thus the largest signal-to-noise ratio measurement, is obtained when operating the ADA2200 with  $\theta_{\text{REL}} = \theta_{\text{DEL}} + 90^\circ = 173^\circ$ . This value of  $\theta_{\text{REL}}$  is also the operating point with the lowest sensitivity to changes in the relative phase. Operating with  $\theta_{\text{REL}} = \theta_{\text{DEL}} - 90^\circ = -7^\circ$  offers the same gain and measurement accuracy, but with a sign inversion.

### PHASE MEASUREMENTS

If the amplitude of the input signal to the ADA2200 remains constant, the output amplitude is a function of the relative phase of the input signal. The relative phase can be measured as

$$\theta_{\text{REL}} = \sin^{-1}(V_{\text{CYCLEMEAN}} / (\text{Conversion Gain} \times V_{\text{IN(RMS)}})) + \theta_{\text{DEL}} = \sin^{-1}(V_{\text{CYCLEMEAN}} / (1.05 \times V_{\text{IN(RMS)}})) + \theta_{\text{DEL}}$$

Note that the output voltage scales directly with the input signal amplitude. A full-scale input signal provides the greatest phase sensitivity ( $V/^\circ\theta_{\text{REL}}$ ) and thus the largest signal-to-noise ratio measurement.

The phase sensitivity also varies with relative phase. The sensitivity is at a maximum when  $\theta_{\text{REL}} = 83^\circ$ . For this reason, the optimal measurement range is for input signals with a relative phase equal to the phase delay of  $\pm 45^\circ$ . This range provides the highest gain and thus the largest signal-to-noise ratio measurement. This range is also the operating point with the lowest sensitivity to changes in the relative phase. Operating at a relative phase equal to the phase delay of  $-135^\circ$  to  $-225^\circ$  offers the same gain and measurement accuracy, but with a sign inversion.

The phase sensitivity with a 4 V p-p differential input operating with a relative phase that is equal to the phase delay results in a phase sensitivity of  $36.6 \text{ mV}/^\circ\theta_{\text{REL}}$ .

### AMPLITUDE AND PHASE MEASUREMENTS

When both the amplitude and relative phase of the input signals are unknown, it is necessary to obtain two orthogonal components of the signal to determine its amplitude, relative phase, or both. These two signal components are referred to as the in-phase (I) and quadrature (Q) components of the signal.

A signal with two known rectangular components is represented as a vector or phasor with an associated amplitude and phase (see Figure 25).

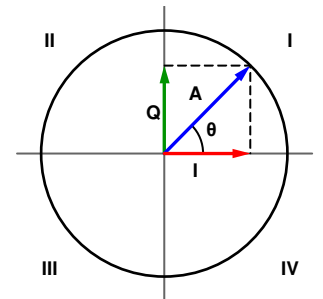

Figure 25. Rectangular and Polar Representation of a Signal

If the signal amplitude remains nearly constant for the duration of the measurement, it is possible to measure both the I and the Q components of the signal by toggling the PHASE90 bit between two consecutive measurements. To measure the I component, set the PHASE90 bit to 0. To measure the Q component, set the PHASE90 bit to 1.

After both the I and Q components have been obtained, it is possible to separate the effects of the amplitude and phase variations. Then, calculate the magnitude and relative phase using the following formulas:

$$A = \sqrt{I^2 + Q^2}$$

$$\theta_{\text{REL}} = \cos^{-1}\left[\frac{Q}{A}\right] + \theta_{\text{DEL}}$$

Or alternatively

$$\theta_{\text{REL}} = \sin^{-1}\left[\frac{I}{A}\right] + \theta_{\text{DEL}}$$

The inverse sine or inverse cosine functions linearize the relationship between the relative phase of the signal and the measured angle. Because the inverse sine and inverse cosine are only defined in two quadrants, the sign of I and Q must be considered to map the result over the entire 360° range of possible relative phase values. The use of the inverse tangent function is not recommended because the phase measurements become extremely sensitive to noise as the calculated phase approaches ±90°.

**ANALOG OUTPUT SYSTEMS**

When the output signal of the ADA2200 is used in the analog domain or if it is sampled asynchronously to the ADA2200 sample clock, it is likely that a reconstruction filter is required.

**Reconstruction Filters**

The bandwidth of the analog reconstruction filter sets the demodulation bandwidth of the analog output. There is a direct trade-off between the noise and demodulation bandwidth. Therefore, it is recommended to ensure that the reconstruction filter cutoff frequency is as low as possible while minimizing the attenuation of the demodulated signal of interest.

Similar to a digital-to-analog converter (DAC), the output of the ADA2200 is a stepwise continuous output. This waveform contains positive and negative images of the desired signal at multiples of  $f_{SO}$ . In most cases, the images are undesired noise components that must be attenuated.

The lowest frequency image to appear in the output spectrum appears at a frequency of  $f_{SO} - f_{IN}$ . The image amplitude is reduced by the  $\sin(x)/x$  roll-off. System accuracy requirements may dictate that additional low-pass filtering is required to remove the output sample images.

**INTERFACING TO ADCS**

**Settling Time Considerations**

If the ADC is coherently sampling the ADA2200 outputs, design the output filter to ensure that the output samples settle prior to ADC sampling. The output filter does not need to remove the sampling images generated by the ADA2200. The images are inherently rejected by the ADC sampling process.

**Clock Synchronization**

The SYNCO output can trigger the ADC sampling process directly, or a microcontroller can use SYNCO to adjust the ADC sampling time. Adjusting the SYNCO pulse timing can maximize the available time for the ADA2200 outputs to settle prior to ADC sampling.

**Multichannel ADCs**

In multichannel systems that require simultaneous sampling, the ADA2200 can provide per channel programmable filtering and simultaneous sampling.

Figure 26 shows an 8-channel system with a 1 MHz aggregate throughput rate. The ADA2200 samples each channel at 1 MSPS and produces filtered samples at an output sample rate of 125 kHz each. The AD7091R-8 is an 8-channel, 1 MHz ADC with multiplexed inputs, which cycle through the eight channels at 125 kHz, producing an aggregate output sample rate of 1 MHz.

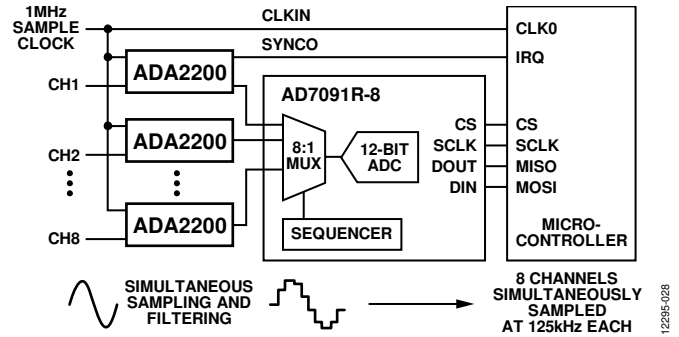

Figure 26. ADA2200 in an 8-Channel Simultaneous Sampling Application

**LOCK-IN AMPLIFIER APPLICATION**

Figure 27 shows the ADA2200 in a lock-in amplifier application. The 80 kHz master clock signal sets the input sample rate of the decimation filter,  $f_{SI}$ . The output sample rate is 10 kHz. In the default configuration, the excitation signal generated by RCLK is 1.25 kHz. This is also the center frequency of the on-chip IIR filter.

In many cases, the RCLK signal is buffered to provide a square wave excitation signal to the sensor. It may also be desirable to provide further signal conditioning to provide a sine wave excitation signal to the sensor.

A low noise instrumentation amplifier provides sufficient gain to amplify the signal so that the noise floor of the signal into the ADA2200 is above the combined noise floor of the ADA2200 and the ADC referred to the ADA2200 inputs.

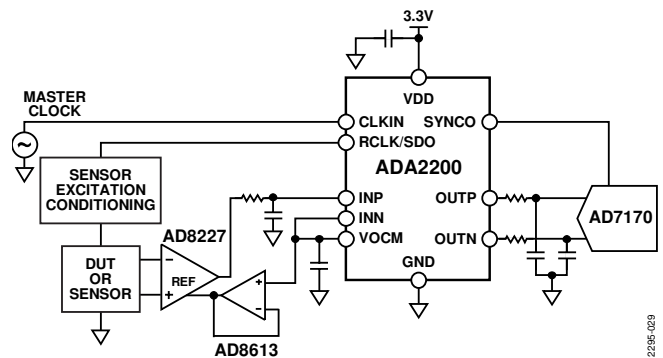

Figure 27. Lock-In Amplifier Application

In default mode, the ADA2200 produces eight output samples for every cycle of the excitation (RCLK) signal. There are four unique output sample values. The fourth value appears on the output for five consecutive output sample periods.

There are several ways of digitally processing the output samples to optimize measurement accuracy, bandwidth, and throughput rate. One method is to take the sum of eight samples to return a value. A moving average filter lowers the noise floor of the returned values. The length of the moving average filter is determined by the noise floor and settling time requirements.

**INTERFACING TO MICROCONTROLLERS**

The diagram in Figure 28 shows basic circuit configuration driven by a low power microcontroller (the ADuCM361). In this case, the ADA2200 reduces the ADC sampling rate by a factor of 8, and reduces the subsequent signal processing required by the microcontroller.

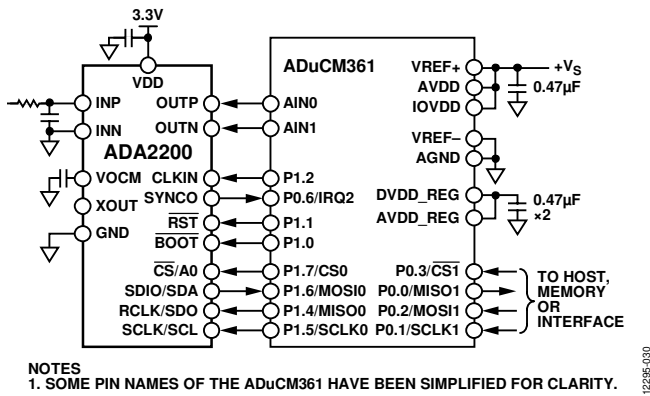

NOTES  
1. SOME PIN NAMES OF THE ADuCM361 HAVE BEEN SIMPLIFIED FOR CLARITY.

Figure 28. Fully Programmable Configuration: Interface to Low Power Microcontroller

**EEPROM BOOT CONFIGURATION**

The diagram in Figure 29 shows a standalone configuration with an EEPROM boot for the ADA2200. The standard oscillator circuit between CLKIN and XOUT generates the clock signal. Holding BOOT low during a power-on reset (POR) forces the ADA2200 to load its configuration from a preprogrammed EEPROM. An EEPROM boot is also initiated by bringing the BOOT pin low while the device is not in reset.

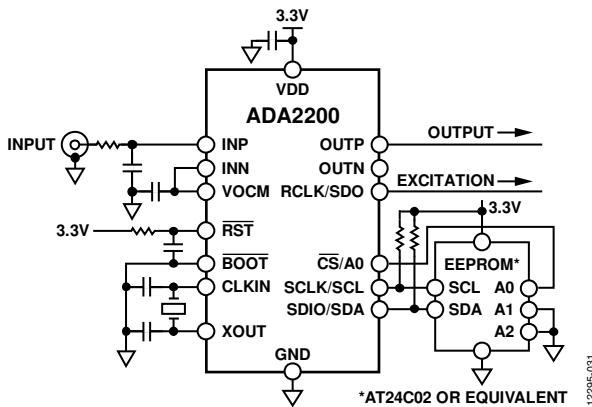

Figure 29. Standalone Configuration

**POWER DISSIPATION**

The ADA2200 current draw is composed of two main components, the amplifier bias currents and the switched capacitor currents. The amplifier currents are independent of clock frequency; the switched capacitor currents scale in direct proportion to  $f_{CLKIN}$ .

Figure 30 shows the ADA2200 measured typical current draw at supply voltages of 2.7 V and 3.3 V, as the input clock varies from 1 kHz to 1 MHz, with CLKIN DIV[2:0] = 1. With a 3.3 V supply voltage, the current draw can be estimated with the following equation:

$$I_{DD} = 290 \times 0.2 \times f_{CLKIN} \mu A$$

where  $f_{CLKIN}$  is specified in kHz.

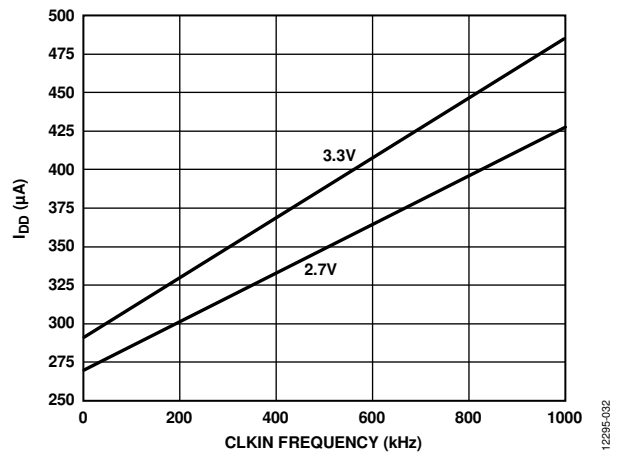

Figure 30. Typical Current Draw vs. CLKIN Frequency at  $V_{DD} = 2.7 V$  and  $3.3 V$



## DEVICE CONFIGURATION

The ADA2200 has several registers that can be programmed to customize the device operation. There are two methods for programming the registers: the device can be programmed over the serial port interface, or the I<sup>2</sup>C master can be used to read the configuration from a serial EEPROM.

### SERIAL PORT OPERATION

The serial port is a flexible, synchronous serial communications port that allows easy interfacing to many industry-standard microcontrollers and microprocessors. The serial I/O is compatible with most synchronous transfer formats, including both the Motorola SPI and Intel® SSR protocols. The interface allows read/write access to all registers that configure the ADA2200. Single-byte or multiple-byte transfers are supported, as well as MSB first or LSB first transfer formats. The serial port interface can be configured as a single-pin I/O (SDIO) or as two unidirectional pins for input and output (SDIO and SDO).

A communication cycle with the ADA2200 has two phases. Phase 1 is the instruction cycle (the writing of an instruction byte into the device), coincident with the first 16 SCLK rising edges. The instruction byte provides the serial port controller with information regarding the data transfer cycle—Phase 2 of the communication cycle. The Phase 1 instruction byte defines whether the upcoming data transfer is a read or write, along with the starting register address for the first byte of the data transfer. The first 16 SCLK rising edges of each communication cycle are used to write the instruction byte into the device.

A logic high on the  $\overline{CS}/A0$  pin followed by a logic low resets the serial port timing to the initial state of the instruction cycle. From this state, the next 16 rising SCLK edges represent the instruction bits of the current I/O operation.

The remaining SCLK edges are for Phase 2 of the communication cycle. Phase 2 is the actual data transfer between the device and the system controller. Phase 2 of the communication cycle is a transfer of one or more data bytes. Registers change immediately upon writing to the last bit of each transfer byte.

### DATA FORMAT

The instruction byte contains the information shown in Table 9.

**Table 9. Serial Port Instruction Byte**

MSB				LSB			
I15	I14	I13	I12	...	I2	I1	I0
R/W	A14	A13	A12	...	A2	A1	A0

R/W, Bit 15 of the instruction byte, determines whether a read or a write data transfer occurs after the instruction byte write. Logic 1 indicates a read operation, and Logic 0 indicates a write operation.

A14 to A0, Bit 14 to Bit 0 of the instruction byte, determine the register that is accessed during the data transfer portion of the communication cycle. For multibyte transfers, A14 is the starting byte address. The remaining register addresses are generated by the device based on the LSB first bit (Register 0x0000, Bit 6).

## SERIAL PORT PIN DESCRIPTIONS

### Serial Clock (SCLK/SCL)

The serial clock pin synchronizes data to and from the device and runs the internal state machines. The maximum frequency of SCLK is 20 MHz. All data input is registered on the rising edge of the SCLK signal. All data is driven out on the falling edge of the SCLK signal.

### Chip Select ( $\overline{CS}/A0$ )

An active low input starts and gates a communication cycle. It allows more than one device to be used on the same serial communications lines. When the  $\overline{CS}/A0$  pin is high, the SDO and SDIO signals go to a high impedance state. Keep the  $\overline{CS}/A0$  pin low throughout the entire communication cycle.

### Serial Data I/O (SDIO/SDA)

Data is always written into the device on this pin. However, this pin can be used as a bidirectional data line. The configuration of this pin is controlled by Register 0x0000, Bit 3 and Bit 4. The default is Logic 0, configuring the SDIO/SDA pin as unidirectional.

### Serial Data Output (RCLK/SDO)

If the ADA2200 is configured for 4-wire SPI operation, this pin can be used as the serial data output pin. If the device is configured for 3-wire SPI operation, this pin can be used as an output for the reference clock (RCLK) signal. Setting the RCLK select bit (Register 0x002A, Bit 3) high activates the RCLK signal.

## SERIAL PORT OPTIONS

The serial port can support both MSB first and LSB first data formats. This functionality is controlled by the LSB first bit (Register 0x0000, Bit 6). The default is MSB first (LSB first = 0).

When the LSB first bit = 0 (MSB first), the instruction and data bits must be written from MSB to LSB. Multibyte data transfers in MSB first format start with an instruction byte that includes the register address of the most significant data byte. Subsequent data bytes follow from high address to low address. In MSB first mode, the serial port internal byte address generator decrements for each data byte of the multibyte communication cycle.

When the LSB first bit = 1, the instruction and data bits must be written from LSB to MSB. Multibyte data transfers in LSB first format start with an instruction byte that includes the register address of the least significant data byte. Subsequent data bytes follow from the low address to the high address. In LSB first mode, the serial port internal byte address generator increments for each data byte of the multibyte communication cycle.

If the MSB first mode is active, the data address is decremented for each successive read or write operation performed in a multibyte register access. If the LSB first mode is active, the data address increments for each successive read or write operation performed in a multibyte register access.

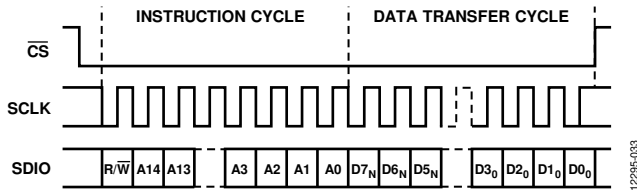

Figure 31. Serial Port Interface Timing, MSB First

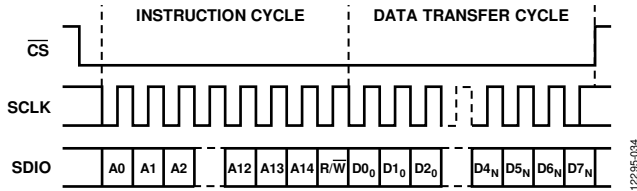

Figure 32. Serial Port Interface Timing, LSB First

**BOOTING FROM EEPROM**

The device can load the internal registers from the EEPROM using the internal I<sup>2</sup>C master to customize the operation of the ADA2200. To enable this feature, the user must control either the RST pin or the BOOT pin. In either case, the device boots from the EEPROM only when it is out of reset and the master clock is active.

**Enabling Load from Memory**

A boot from the EEPROM is initiated by two methods. To initiate loading via the BOOT pin, the device must be out of reset, and the BOOT pin is brought low for a minimum of two clock cycles of the master clock. After it is initiated, the boot completes irrespective of the state of the BOOT pin. To initiate subsequent boots, the BOOT pin must be brought high and then low for a minimum of two clock cycles of the master clock. To initiate loading via the RST pin, the BOOT pin must be low. The RST pin can be tied high and the ADA2200 loads from the EEPROM when the device is powered up and the internal POR cycle completes. To initiate subsequent boots, the ADA2200 can be power cycled or the RST pin can be brought low and then high.

The SPI interface is disabled while the ADA2200 is loading the EEPROM.

**Load from Memory Cycle**

The ADA2200 reads the first 28 bytes of the EEPROM. The first 27 bytes represent the contents to be loaded into Register 0x0011 to Register 0x0027. Byte 28 contains the checksum stored in the EEPROM.

The ADA2200 calculates the checksum for the first 27 bytes that it reads back and compares it to the checksum in the EEPROM. The ADA2200 calculated checksum is accessible by reading the EEPROM checksum register (Register 0x002E). If the ADA2200 checksum matches the checksum stored in the EEPROM, the load from the EEPROM was successful. The load from the EEPROM pass or fail status is recorded in the EEPROM status register (Register 0x002F).

In addition, the LSB of the EEPROM status register indicates whether the load cycle is complete. Logic 1 represents successful completion of the load cycle. Logic 0 represents the occurrence of a timeout violation during the loading cycle. In the event of a timeout or the successful completion of the load from a memory cycle, the ADA2200 I<sup>2</sup>C master interface disables, and the ADA2200 SPI interface reenables, allowing the user communication access to the device.

The load cycle completes within 10,000 clock cycles of CLKIN (or CLKIN divided by the current value of CLKIN DIV[2:0] if the load cycle is being initiated by the BOOT pin).

**Dual Configuration/Dual Device Memory Load**

The CS/A0 pin allows a single EEPROM device to support a dual configuration for a single ADA2200 device or different configurations for two different ADA2200 devices. To ensure reliable operation, set the CS/A0 pin to the desired state before initiating a boot, and then hold the state for the entire duration of the boot.

To configure a single ADA2200 device, the EEPROM must have a word page size that supports a minimum of 32 words, each of 8 bits per word. To support two devices, or a dual configuration for a single device, the EEPROM must have at least two word pages. The ADA2200 configuration data for each device must be allocated to the EEPROM memory within a single word page.

**Using SPI Master with EEPROM Loading**

The load from a memory cycle requires an I<sup>2</sup>C communication bus between the ADA2200 and the EEPROM device; however, the ADA2200 can still be controlled by the SPI interface after the load from the memory cycle is complete. It is recommended that the CS/A0 pin return to logic high after the load from the memory cycle and before the first SPI read or write command. This allows the user to ensure that the proper setup time elapses before the initiation of a SPI read/write command (see Table 2).

## DEVICE CONFIGURATION REGISTER MAP AND DESCRIPTIONS

Table 10. Device Configuration Register Map<sup>1</sup>

Addr. (Hex)	Register Name	Bit 7	Bit 6	Bit 5	Bit 4	Bit 3	Bit 2	Bit 1	Bit 0	Default <sup>2</sup>
0x0000	Serial interface	Reset	LSB first	Address increment	SDO active	SDO active	Address increment	LSB first	Reset	0x00
0x0006	Chip type	0	0	0	0	Die revision[3:0]			0x00 (read only)	
0x0010	Filter strobe	0	0	0	0	0	0	Load coefficients[1:0]		0x00
0x0011 to 0x0027	Filter configuration	Coefficient[7:0]								See Table 11
0x0028	Analog pin configuration	X	X	X	X	X	X	INP gain	Clock source select	0x00
0x0029	Sync control	X	X	SYNCO output enable	SYNCO invert	SYNCO edge select[3:0]			0x2D	
0x002A	Demod control	X	PHASE90	X	Mixer enable	RCLK select	VOCM select[2:0]		0x18	
0x002B	Clock configuration	X	X	X	CLKIN DIV[2:0]			RCLK DIV[1:0]		0x02
0x002C	Digital pin configuration	X	X	X	X	X	X	X	RCLK/SDO output enable	0x01
0x002D	Core reset	X	X	X	X	X	X	X	Core reset	0x00
0x002E	Checksum	Checksum value[7:0]								N/A (read only)
0x002F	EEPROM status	X	X	X	X	X	Checksum failed	Checksum passed	Boot from EEPROM complete	N/A (read only)

<sup>1</sup> X means don't care.

<sup>2</sup> N/A means not applicable.

Table 11. Device Configuration Register Descriptions

Name	Address (Hex)	Bits	Bit Name	Description	Default <sup>1</sup>
Serial Interface	0x0000	7	Reset	Writing a 1 to this bit places the device in reset. The device remains in reset until a 0 is written to this bit. All of the configuration registers return to their default values.	0
		6	LSB first	Serial port communication, LSB or MSB first. 0 = MSB first. 1 = LSB first.	0
		5	Address increment	Controls address increment mode for multibyte register access. 0 = address decrement. 1 = address increment.	0
		4	SDO active	4-wire SPI select. 0 = SDIO operates as a bidirectional input/output. The SDO signal is disabled. 1 = SDIO operates as an input only. The SDO signal is active.	0
		3	SDO active	This bit is a mirror of Bit 4 in Register 0x0000.	0
		2	Address increment	This bit is a mirror of Bit 5 in Register 0x0000.	0
		1	LSB first	This bit is a mirror of Bit 6 in Register 0x0000.	0
		0	Reset	This bit is a mirror of Bit 7 in Register 0x0000.	0
Chip Type	0x0006	[3:0]	Die revision[3:0]	Die revision number.	0000

Name	Address (Hex)	Bits	Bit Name	Description	Default <sup>1</sup>
Filter Strobe	0x0010	[7:0]	Load coefficients[1:0]	When toggled from 0 to 1, the filter coefficients in configuration Register 0x0011 through Register 0x0027 are loaded into the IIR filter.	00
Filter Configuration	0x0011	[7:0]	Coefficient[7:0]	Programmable filter coefficients.	0xC02 <sup>2</sup>
	0x0012	[7:0]	Coefficient[7:0]	Programmable filter coefficients.	0x0F <sup>2</sup>
	0x0013	[7:0]	Coefficient[7:0]	Programmable filter coefficients.	0x1D <sup>2</sup>
	0x0014	[7:0]	Coefficient[7:0]	Programmable filter coefficients.	0xD7 <sup>2</sup>
	0x0015	[7:0]	Coefficient[7:0]	Programmable filter coefficients.	0xC0 <sup>2</sup>
	0x0016	[7:0]	Coefficient[7:0]	Programmable filter coefficients.	0x0F <sup>2</sup>
	0x0017	[7:0]	Coefficient[7:0]	Programmable filter coefficients.	0xC0 <sup>2</sup>
	0x0018	[7:0]	Coefficient[7:0]	Programmable filter coefficients.	0x0F <sup>2</sup>
	0x0019	[7:0]	Coefficient[7:0]	Programmable filter coefficients.	0x1D <sup>2</sup>
	0x001A	[7:0]	Coefficient[7:0]	Programmable filter coefficients.	0x97 <sup>2</sup>
	0x001B	[7:0]	Coefficient[7:0]	Programmable filter coefficients.	0x7E <sup>2</sup>
	0x001C	[7:0]	Coefficient[7:0]	Programmable filter coefficients.	0x88 <sup>2</sup>
	0x001D	[7:0]	Coefficient[7:0]	Programmable filter coefficients.	0xC0 <sup>2</sup>
	0x001E	[7:0]	Coefficient[7:0]	Programmable filter coefficients.	0x0F <sup>2</sup>
	0x001F	[7:0]	Coefficient[7:0]	Programmable filter coefficients.	0xC0 <sup>2</sup>
	0x0020	[7:0]	Coefficient[7:0]	Programmable filter coefficients.	0x0F <sup>2</sup>
	0x0021	[7:0]	Coefficient[7:0]	Programmable filter coefficients.	0xC0 <sup>2</sup>
	0x0022	[7:0]	Coefficient[7:0]	Programmable filter coefficients.	0x0F <sup>2</sup>
0x0023	[7:0]	Coefficient[7:0]	Programmable filter coefficients.	0x00 <sup>2</sup>	
0x0024	[7:0]	Coefficient[7:0]	Programmable filter coefficients.	0xE0 <sup>2</sup>	
0x0025	[7:0]	Coefficient[7:0]	Programmable filter coefficients.	0x23 <sup>2</sup>	
0x0026	[7:0]	Coefficient[7:0]	Programmable filter coefficients.	0x02 <sup>2</sup>	
0x0027	[7:0]	Coefficient[7:0]	Programmable filter coefficients.	0x24 <sup>2</sup>	
Analog Pin Configuration	0x0028	1	INP gain	1 = only the INP input signal is sampled. An additional 6 dB of gain is applied to the signal path.	0
		0	Clock source select	0 = device is configured to generate a clock if a crystal or resonator is placed between the XOUT and CLKIN pins. 1 = device is configured to accept a CMOS level clock on the CLKIN pin. The internal XOUT driver is disabled.	0
Sync Control	0x0029	5	SYNCO output enable	1 = enables the SYNCO output pad driver.	1
		4	SYNCO invert	1 = inverts the SYNCO signal.	0
		[3:0]	SYNCO edge select	These bits select one of 16 different edge locations for the SYNCO pulse relative to the output sample window. See Figure 24 for details.	1101
Demod Control	0x002A	6	PHASE90	1 = delays the phase between the RCLK output and the strobe controlling the mixing signal. See Figure 23 for details.	0
		4	Mixer enable	1 = the last sample that is taken while RCLK is active remains held while RCLK is inactive.	1
		3	RCLK select	0 = sends the SDO signal to the output driver of Pin 13. 1 = sends the RCLK signal to the output driver of Pin 13.	1
		[2:0]	VOCM select	000 = set the VOCM pin to $V_{DD}/2$ . Low power mode. 001 = use the external reference to drive VOCM. 010 = set the VOCM pin to $V_{DD}/2$ . Fast settling mode. 101 = set the VOCM pin to 1.2 V.	000

Name	Address (Hex)	Bits	Bit Name	Description	Default <sup>1</sup>
Clock Configuration	0x002B	[4:2]	CLKIN DIV[2:0]	The division factor between $f_{CLKIN}$ and $f_{SI}$ . 000 = divide by 1. 001 = divide by 16. 010 = divide by 64. 100 = divide by 256.	000
		[1:0]	RCLK DIV[1:0]	These bits set the division factor between $f_{SO}$ and $f_M$ . 00 = reserved. 01 = the frequency of RCLK is $f_{SO}/4$ . 10 = the frequency of RCLK is $f_{SO}/8$ . 11 = reserved.	10
Digital Pin Configuration	0x002C	0	RCLK/SDO output enable	1 = RCLK/SDO output pad driver is enabled.	1
Core Reset	0x002D	0	Core reset	1 = puts the device core into reset. The values of the SPI registers are preserved. This does not initiate a boot from the EEPROM. 0 = core reset is deasserted.	0
Checksum	0x002E	[7:0]	Checksum value[7:0]	This is the 8-bit checksum calculated by the ADA2200, performed on the data it reads from the EEPROM.	N/A
EEPROM Status	0x002F	2	Checksum failed	1 = calculated checksum does not match the checksum byte read from the EEPROM.	N/A
		1	Checksum passed	1 = calculated checksum matches the checksum byte read from the EEPROM.	N/A
		0	Boot from EEPROM complete	1 = boot from the EEPROM has completed. 0 = boot from the EEPROM has timed out. Wait 10,000 clock cycles after the boot is initiated to check for boot completion.	N/A

<sup>1</sup> NA/ means not applicable.

<sup>2</sup> The filter coefficients listed are the default values programmed into the filter on reset. The value read back from the registers is 0x00.

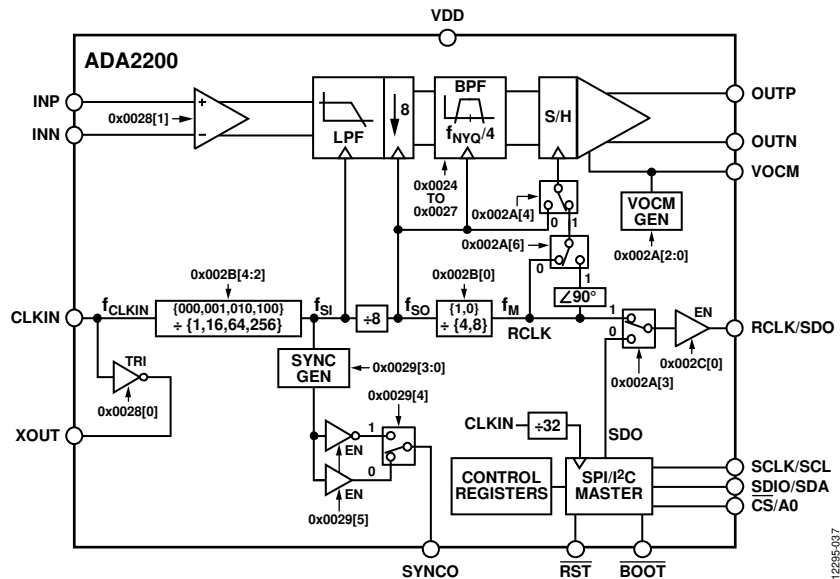
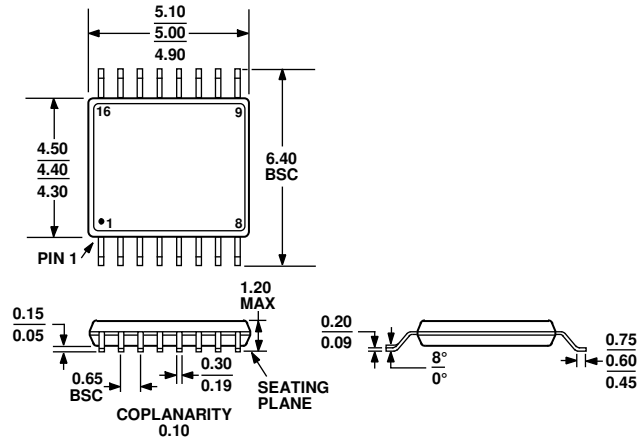

Figure 33. Detailed Block Diagram

OUTLINE DIMENSIONS



COMPLIANT TO JEDEC STANDARDS MO-153-AB

Figure 34. 16-Lead Thin Shrink Small Outline Package [TSSOP] (RU-16)

Dimensions shown in millimeters

ORDERING GUIDE

Model <sup>1</sup>	Temperature Range	Package Description	Package Option
ADA2200ARUZ	-40°C to +85°C	16-Lead Thin Shrink Small Outline Package [TSSOP]	RU-16
ADA2200ARUZ-REEL7	-40°C to +85°C	16-Lead Thin Shrink Small Outline Package [TSSOP]	RU-16
ADA2200-EVALZ		Evaluation board with EEPROM boot	
ADA2200SDP-EVALZ		Evaluation board with SDP-B interface option	

<sup>1</sup> Z = RoHS-Compliant Part.

I<sup>2</sup>C refers to a communications protocol originally developed by Philips Semiconductors (now NXP Semiconductors).