



Chipsmall Limited consists of a professional team with an average of over 10 year of expertise in the distribution of electronic components. Based in Hongkong, we have already established firm and mutual-benefit business relationships with customers from,Europe,America and south Asia,supplying obsolete and hard-to-find components to meet their specific needs.

With the principle of “Quality Parts,Customers Priority,Honest Operation,and Considerate Service”,our business mainly focus on the distribution of electronic components. Line cards we deal with include Microchip,ALPS,ROHM,Xilinx,Pulse,ON,Everlight and Freescale. Main products comprise IC,Modules,Potentiometer,IC Socket,Relay,Connector.Our parts cover such applications as commercial,industrial, and automotives areas.

We are looking forward to setting up business relationship with you and hope to provide you with the best service and solution. Let us make a better world for our industry!



Contact us

Tel: +86-755-8981 8866 Fax: +86-755-8427 6832

Email & Skype: info@chipsmall.com Web: www.chipsmall.com

Address: A1208, Overseas Decoration Building, #122 Zhenhua RD., Futian, Shenzhen, China



ADBL-A321 Optical Finger Navigation Lens



Data Sheet



Lead (Pb) Free
RoHS 6 fully
compliant



Description

The ADBL-A321 Optical Finger Navigation Lens is designed for use with Avago Technologies ADBS-A320 Optical Finger Navigation sensor. The ADBL-A321 lens provides the direct illumination and optical imaging necessary for proper operation of the sensor. ADBL-A321 lens is a precision molded optical component and should be handled with care to avoid scratching of the optical surfaces. The lens material is polycarbonate. Cyanoacrylate based adhesives should not be used as they will cause lens material deformation.

Lens should not be subjected to temperatures higher than 85°C for 30 minutes during assembly. Lens can be operated in a temperature range from -20°C to 80°C.

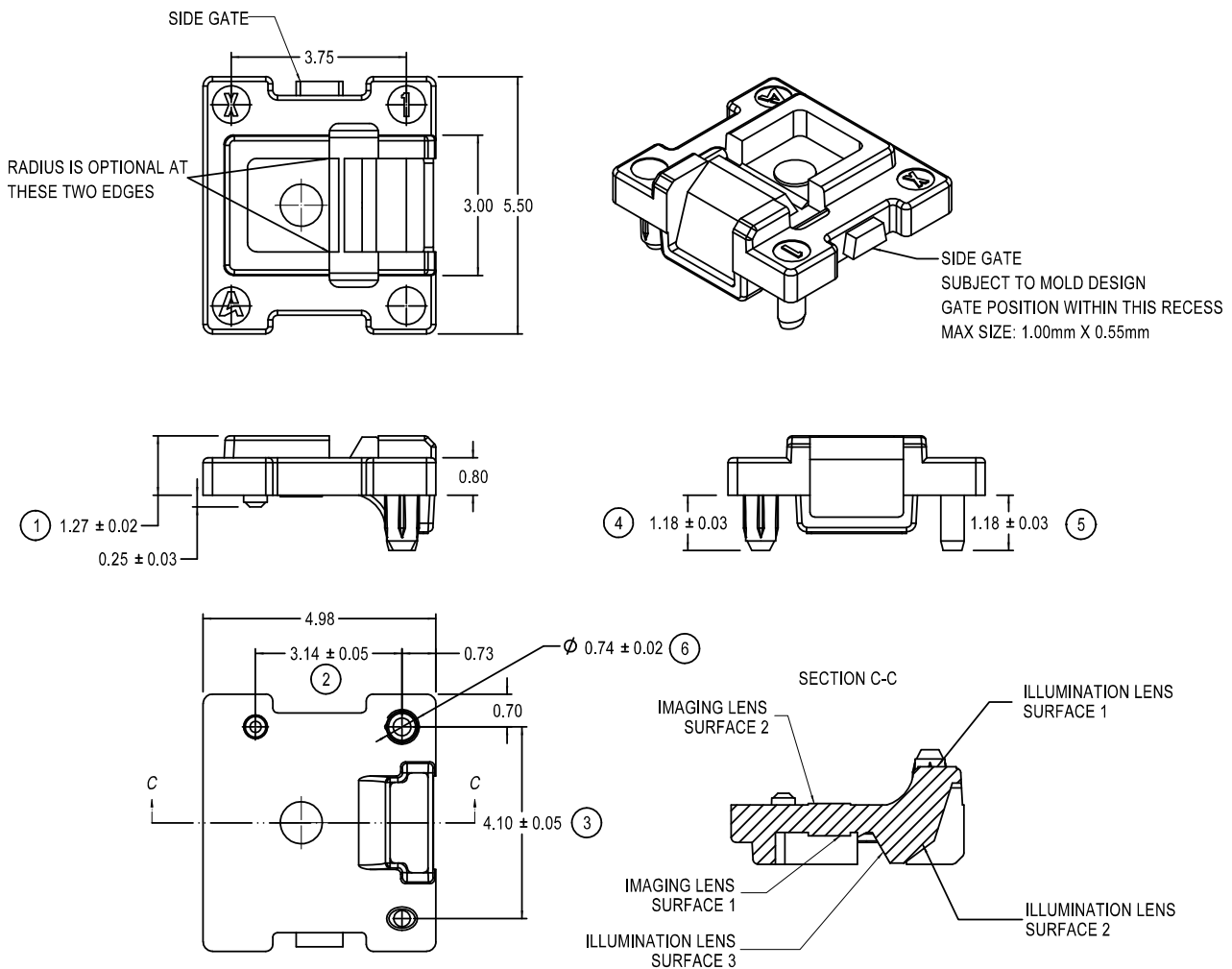

NOTES:

1. DIMENSIONS IN MILLIMETERS.
2. DIMENSIONAL TOLERANCES : $\pm 0.1\text{mm}$ UNLESS OTHERWISE SPECIFIED.
3. ANGULAR TOLERANCES : $\pm 3^\circ$.
4. MAXIMUM FLASH : + 0.2mm.
5. ALL CRITICAL DIMENSIONS ARE INDICATED BY A NUMBER ENCLOSED IN A CIRCLE.

Figure 1. ADBL-A321 Optical Finger Navigation lens outline drawings and details

Mounting Instructions for the ADBL-A321 Lens to the Base Plate

An IGES format drawing file with design specifications for mouse base plate features is available.

These features are useful in maintaining proper positioning and alignment of the ADBL-A321 when used with the Avago Technologies Optical Sensor. This file can be obtained by contacting your local Avago Technologies sales representative.

Handling Instructions for the ADBL-A321 Lens

Several careful handling instructions must be observed when handling lens. They are listed below:-

1. Pick up the lens at the lens side using a pair of tweezers from the tray. See figure 2.
2. Do not touch the optical surfaces as highlighted in red of the lens. See figure 3a, 3b.
3. It is recommended to use clean dry air CDA air blow system to clean the lens before assembly to minimize particle contamination.



Figure 2. Handling lens

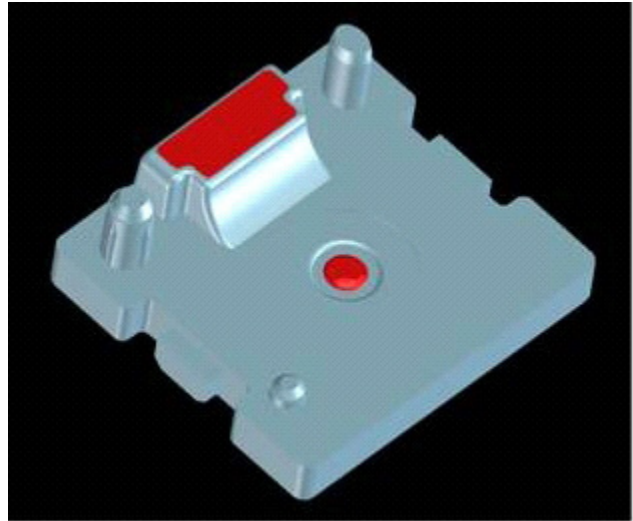

Figure 3a. Lens bottom view

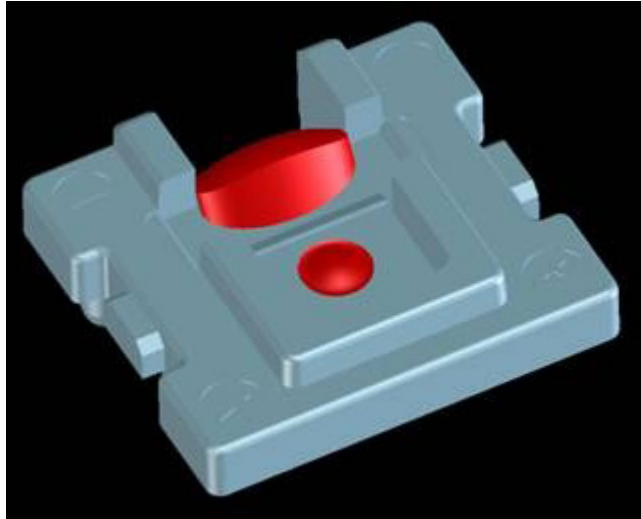

Figure 3b. Lens top view

Packaging information

There are two type of lens packaging-lens tray type 1 and type 2. The lens packaging information shown below.

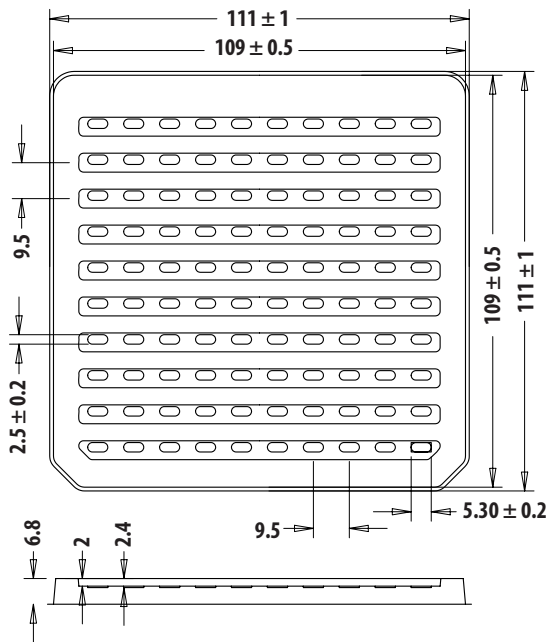

Figure 4a. Lens tray type 1 - top cover

Notes:

1. Max draft to be 5 deg. unless stated
2. All radii to be 1.25 unless otherwise stated
3. All surface resistivity $>10e12$ Ohm/sq unless otherwise stated
4. All cells are identical

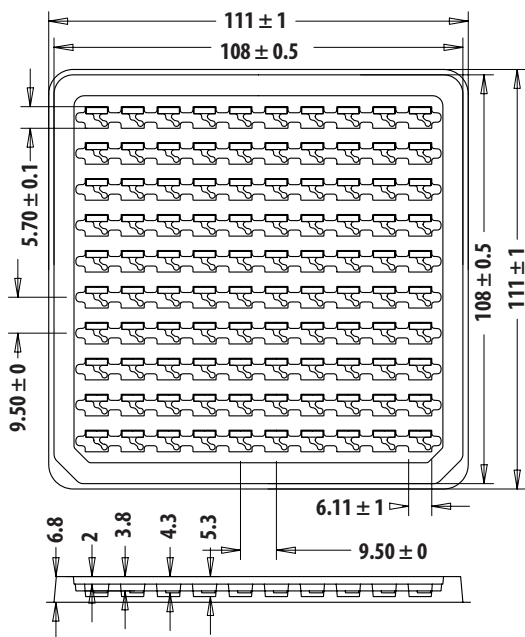

Figure 4b. Lens tray type 1 - base

Notes:

1. Max draft to be 5 deg. unless stated
2. All radii to be 1.25 unless otherwise stated
3. All surface resistivity $>10e12$ Ohm/sq unless otherwise stated
4. All cells are identical

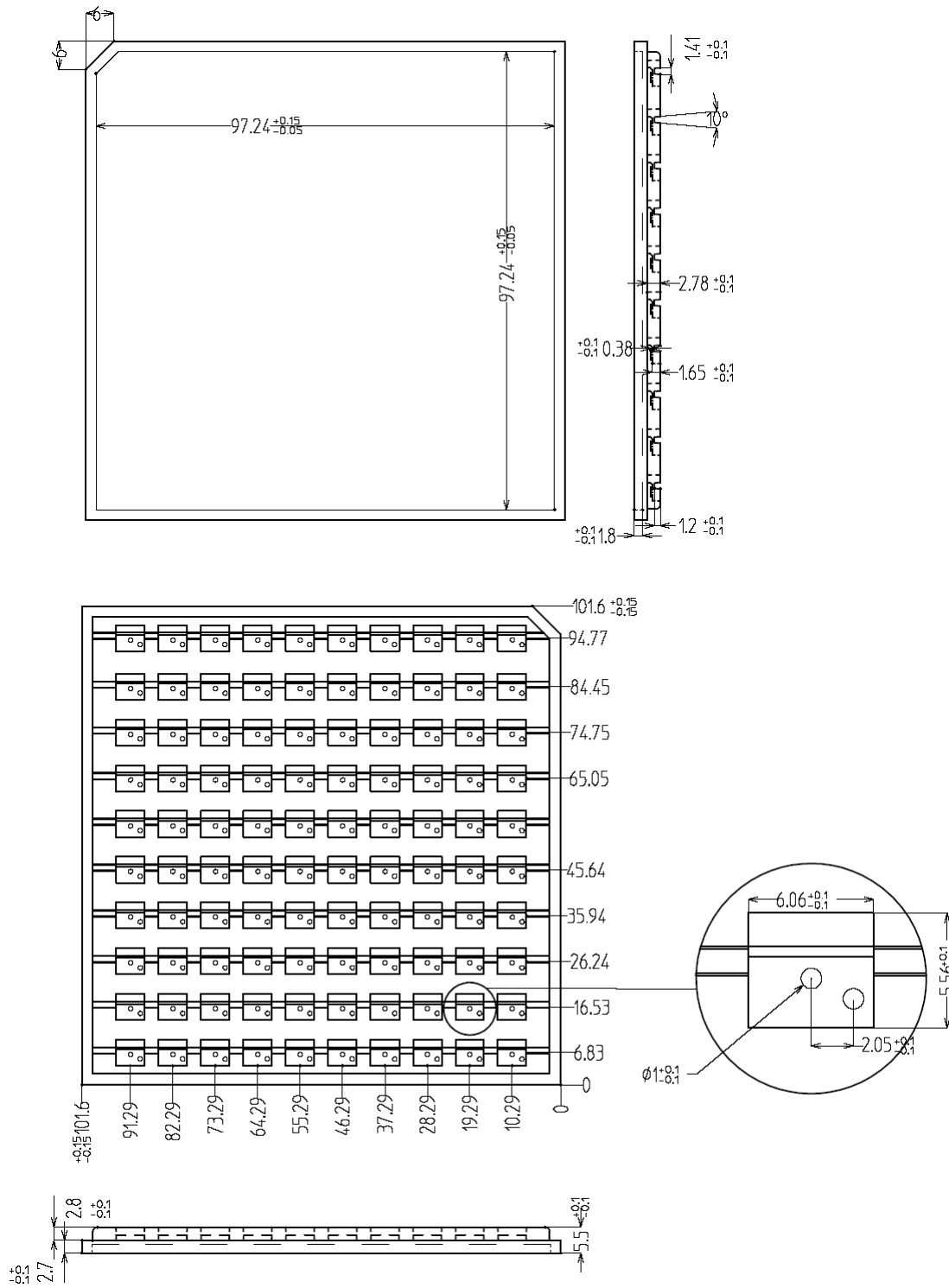

Figure 5. Lens tray type 2

For product information and a complete list of distributors, please go to our web site: www.avagotech.com

Avago, Avago Technologies, and the A logo are trademarks of Avago Technologies in the United States and other countries. Data subject to change. Copyright © 2005-2010 Avago Technologies. All rights reserved. AV02-1911EN - December 21, 2010

