



Chipsmall Limited consists of a professional team with an average of over 10 year of expertise in the distribution of electronic components. Based in Hongkong, we have already established firm and mutual-benefit business relationships with customers from,Europe,America and south Asia,supplying obsolete and hard-to-find components to meet their specific needs.

With the principle of “Quality Parts,Customers Priority,Honest Operation,and Considerate Service”,our business mainly focus on the distribution of electronic components. Line cards we deal with include Microchip,ALPS,ROHM,Xilinx,Pulse,ON,Everlight and Freescale. Main products comprise IC,Modules,Potentiometer,IC Socket,Relay,Connector.Our parts cover such applications as commercial,industrial, and automotives areas.

We are looking forward to setting up business relationship with you and hope to provide you with the best service and solution. Let us make a better world for our industry!



Contact us

Tel: +86-755-8981 8866 Fax: +86-755-8427 6832

Email & Skype: info@chipsmall.com Web: www.chipsmall.com

Address: A1208, Overseas Decoration Building, #122 Zhenhua RD., Futian, Shenzhen, China



ADC1015S series

Single 10-bit ADC; 65 Msps, 80 Msps, 105 Msps or 125 Msps with input buffer; CMOS or LVDS DDR digital outputs

Rev. 03 — 2 July 2012

Product data sheet

1. General description

The ADC1015S is a single channel 10-bit Analog-to-Digital Converter (ADC) optimized for high dynamic performances and low power consumption at sample rates up to 125 Msps. Pipelined architecture and output error correction ensure the ADC1015S is accurate enough to guarantee zero missing codes over the entire operating range. Supplied from a single 3 V source, it can handle output logic levels from 1.8 V to 3.3 V in CMOS mode, because of a separate digital output supply.

The ADC1015S supports the Low Voltage Differential Signalling (LVDS) Double Data Rate (DDR) output standard. An integrated Serial Peripheral Interface (SPI) allows the user to easily configure the ADC.

The device also includes a SPI programmable full-scale to allow flexible input voltage range from 1 V to 2 V (peak-to-peak). With excellent dynamic performance from the baseband to input frequencies of 170 MHz or more, the ADC1015S is ideal for use in communications, imaging and medical applications - especially in high Intermediate Frequency (IF) applications because of the integrated input buffer. The input buffer ensures that the input impedance remains constant and low and the performance consistent over a wide frequency range.

2. Features and benefits

- SNR, 61.7 dBFS / SFDR, 86 dBc
- Sample rate up to 125 Msps
- 10-bit pipelined ADC core
- Clock input divided by 2 for less jitter contribution
- Integrated input buffer
- Flexible input voltage range: 1 V (p-p) to 2 V (p-p)
- CMOS or LVDS DDR digital outputs
- Pin compatible with the ADC1415S series, the ADC1215S series and the ADC1115S125
- Input bandwidth, 600 MHz
- Power dissipation, 635 mW at 80 Msps, including analog input buffer
- Serial Peripheral Interface (SPI)
- Duty cycle stabilizer
- Fast Out-of-Range (OTR) detection
- Offset binary, two's complement, gray code
- Power-down mode and Sleep mode
- HVQFN40 package



3. Applications

- Wireless and wired broadband communications
- Portable instrumentation
- Imaging systems
- Digital predistortion loop, power amplifier linearization
- Spectral analysis
- Ultrasound equipment
- Software defined radio

4. Ordering information

Table 1. Ordering information

| Type number | f _s (MSPs) | Package | | |
|------------------|-----------------------|---------|--|----------|
| | | Name | Description | Version |
| ADC1015S125HN-C1 | 125 | HVQFN40 | plastic thermal enhanced very thin quad flat package; no leads; 40 terminals; body 6 × 6 × 0.85 mm | SOT618-6 |
| ADC1015S105HN-C1 | 105 | HVQFN40 | plastic thermal enhanced very thin quad flat package; no leads; 40 terminals; body 6 × 6 × 0.85 mm | SOT618-6 |
| ADC1015S080HN-C1 | 80 | HVQFN40 | plastic thermal enhanced very thin quad flat package; no leads; 40 terminals; body 6 × 6 × 0.85 mm | SOT618-6 |
| ADC1015S065HN-C1 | 65 | HVQFN40 | plastic thermal enhanced very thin quad flat package; no leads; 40 terminals; body 6 × 6 × 0.85 mm | SOT618-6 |

5. Block diagram

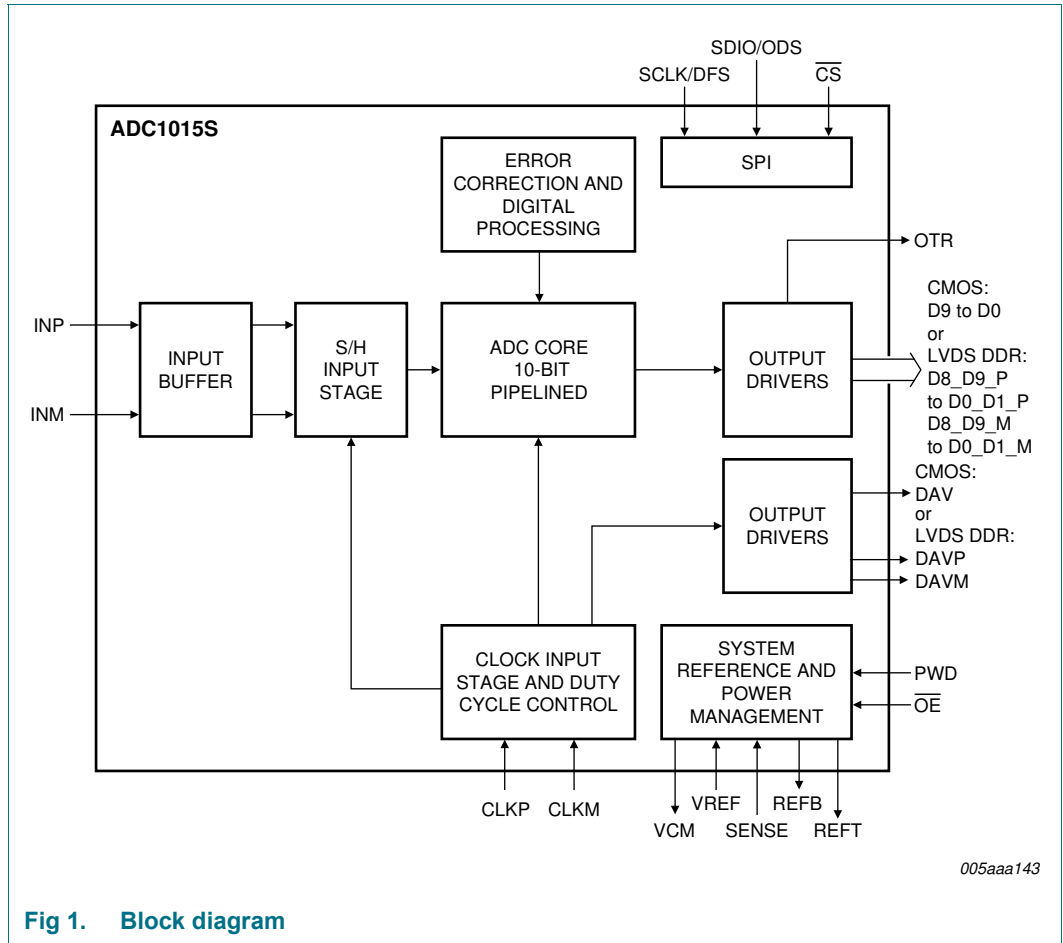
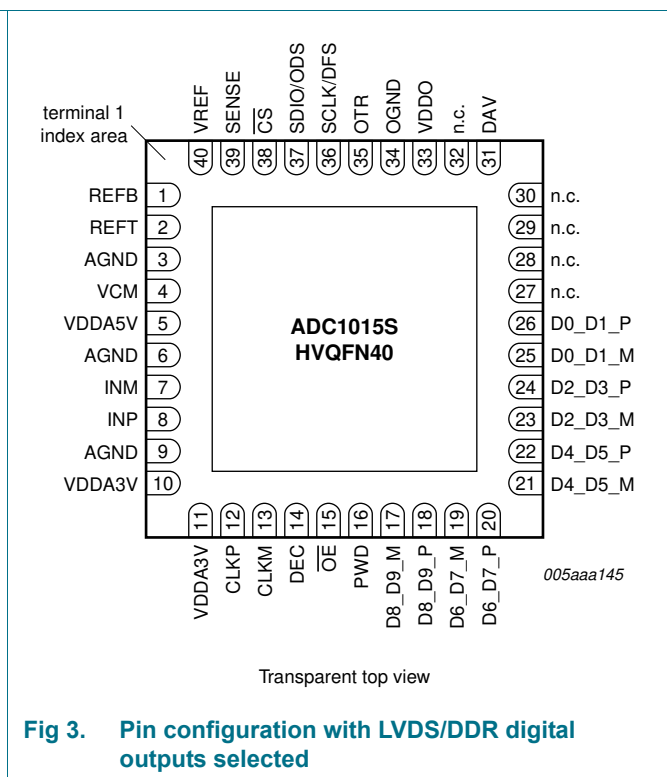
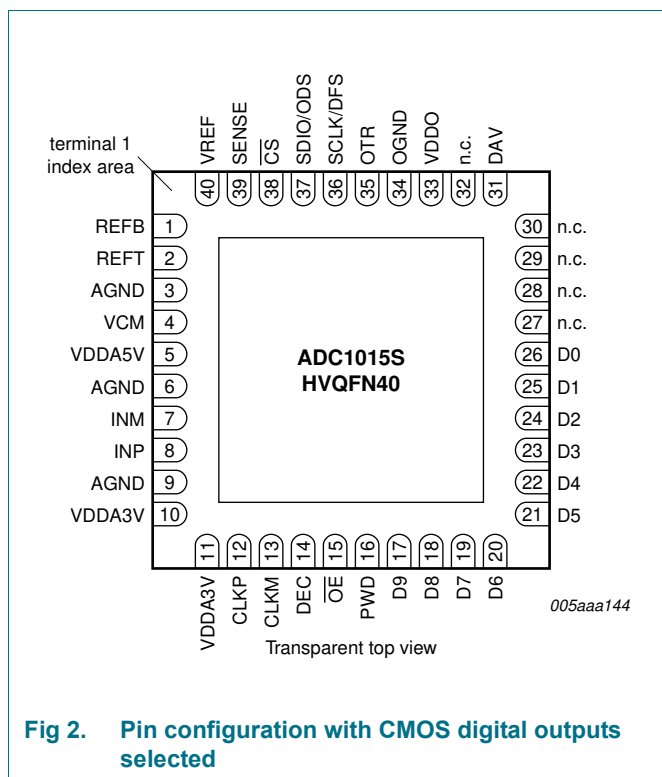

Fig 1. Block diagram

6. Pinning information

6.1 Pinning



6.2 Pin description

Table 2. Pin description (CMOS digital outputs)

| Symbol | Pin | Type ^[1] | Description |
|--------|-----|---------------------|----------------------------|
| REFB | 1 | O | bottom reference |
| REFT | 2 | O | top reference |
| AGND | 3 | G | analog ground |
| VCM | 4 | O | common-mode output voltage |
| VDDA5V | 5 | P | 5 V analog power supply |
| AGND | 6 | G | analog ground |
| INM | 7 | I | complementary analog input |
| INP | 8 | I | analog input |
| AGND | 9 | G | analog ground |
| VDDA3V | 10 | P | 3 V analog power supply |
| VDDA3V | 11 | P | 3 V analog power supply |
| CLKP | 12 | I | clock input |
| CLKM | 13 | I | complementary clock input |
| DEC | 14 | O | regulator decoupling node |
| OE | 15 | I | output enable, active LOW |
| PWD | 16 | I | power down, active HIGH |

Table 2. Pin description (CMOS digital outputs)

| Symbol | Pin | Type ^[1] | Description |
|------------------------|-----|---------------------|---|
| D9 | 17 | O | data output bit 9 (Most Significant Bit (MSB)) |
| D8 | 18 | O | data output bit 8 |
| D7 | 19 | O | data output bit 7 |
| D6 | 20 | O | data output bit 6 |
| D5 | 21 | O | data output bit 5 |
| D4 | 22 | O | data output bit 4 |
| D3 | 23 | O | data output bit 3 |
| D2 | 24 | O | data output bit 2 |
| D1 | 25 | O | data output bit 1 |
| D0 | 26 | O | data output bit 0 (Least Significant Bit (LSB)) |
| n.c. | 27 | - | not connected |
| n.c. | 28 | - | not connected |
| n.c. | 29 | - | not connected |
| n.c. | 30 | - | not connected |
| DAV | 31 | O | data valid output clock |
| n.c. | 32 | - | not connected |
| VDDO | 33 | P | output power supply |
| OGND | 34 | G | output ground |
| OTR | 35 | O | out of range |
| SCLK/DFS | 36 | I | SPI clock / data format select |
| SDIO/ODS | 37 | I/O | SPI data IO / output data standard |
| $\overline{\text{CS}}$ | 38 | I | SPI chip select |
| SENSE | 39 | I | reference programming pin |
| VREF | 40 | I/O | voltage reference input/output |

[1] P: power supply; G: ground; I: input; O: output; I/O: input/output.

Table 3. Pin description (LVDS/DDR) digital outputs

| Symbol | Pin ^[1] | Type ^[2] | Description |
|---------|--------------------|---------------------|--|
| D8_D9_M | 17 | O | differential output data D8 and D9 multiplexed, complement |
| D8_D9_P | 18 | O | differential output data D8 and D9 multiplexed, true |
| D6_D7_M | 19 | O | differential output data D6 and D7 multiplexed, complement |
| D6_D7_P | 20 | O | differential output data D6 and D7 multiplexed, true |
| D4_D5_M | 21 | O | differential output data D4 and D5 multiplexed, complement |
| D4_D5_P | 22 | O | differential output data D4 and D5 multiplexed, true |
| D2_D3_M | 23 | O | differential output data D2 and D3 multiplexed, complement |
| D2_D3_P | 24 | O | differential output data D2 and D3 multiplexed, true |
| D0_D1_M | 25 | O | differential output data D0 and D1 multiplexed, complement |
| D0_D1_P | 26 | O | differential output data D0 and D1 multiplexed, true |
| n.c. | 27 | - | not connected |
| n.c. | 28 | - | not connected |
| n.c. | 29 | - | not connected |

Table 3. Pin description ...continued (LVDS/DDR) digital outputs)

| Symbol | Pin ^[1] | Type ^[2] | Description |
|--------|--------------------|---------------------|-------------------------------------|
| n.c. | 30 | - | not connected |
| DAVM | 31 | O | data valid output clock, complement |
| DAVP | 32 | O | data valid output clock, true |

[1] Pins 1 to 16 and pins 33 to 40 are the same for both CMOS and LVDS DDR outputs (see Table 2)

[2] P: power supply; G: ground; I: input; O: output; I/O: input/output.

7. Limiting values

Table 4. Limiting values

In accordance with the Absolute Maximum Rating System (IEC 60134).

| Symbol | Parameter | Conditions | Min | Max | Unit |
|---------------|---------------------------|---|------|------|------|
| V_O | output voltage | pins D9 to D0 or pins D8_D9_P to D0_D1_P and D8_D9_M to D0_D1_M | -0.4 | +3.9 | V |
| $V_{DDA(3V)}$ | analog supply voltage 3 V | on pin VDDA3V | -0.5 | +4.6 | V |
| $V_{DDA(5V)}$ | analog supply voltage 5 V | on pin VDDA5V | -0.5 | +4.6 | V |
| V_{DDO} | output supply voltage | | -0.5 | +4.6 | V |
| T_{stg} | storage temperature | | -55 | +125 | °C |
| T_{amb} | ambient temperature | | -40 | +85 | °C |
| T_j | junction temperature | | - | 125 | °C |

8. Thermal characteristics

Table 5. Thermal characteristics

| Symbol | Parameter | Conditions | Typ | Unit |
|---------------|---|------------|---------------------|------|
| $R_{th(j-a)}$ | thermal resistance from junction to ambient | | ^[1] 30.5 | K/W |
| $R_{th(j-c)}$ | thermal resistance from junction to case | | ^[1] 13.3 | K/W |

[1] Value for six layers board in still air with a minimum of 25 thermal vias.

9. Static characteristics

Table 6. Static characteristics^[1]

| Symbol | Parameter | Conditions | Min | Typ | Max | Unit |
|---|----------------------------------|---|------------------|-----------|------------------|---------|
| Supplies | | | | | | |
| $V_{DDA(5V)}$ | analog supply voltage 5 V | | 4.75 | 5.0 | 5.25 | V |
| $V_{DDA(3V)}$ | analog supply voltage 3 V | | 2.85 | 3.0 | 3.4 | V |
| V_{DDO} | output supply voltage | CMOS mode | 1.65 | 1.8 | 3.6 | V |
| | | LVDS DDR mode | 2.85 | 3.0 | 3.6 | V |
| $I_{DDA(5V)}$ | analog supply current 5 V | $f_{clk} = 125$ Msps; $f_i = 70$ MHz | - | 46 | - | mA |
| $I_{DDA(3V)}$ | analog supply current 3 V | $f_{clk} = 125$ Msps; $f_i = 70$ MHz | - | 205 | - | mA |
| I_{DDO} | output supply current | CMOS mode; $f_{clk} = 125$ Msps; $f_i = 70$ MHz | - | 10 | - | mA |
| | | LVDS DDR mode: $f_{clk} = 125$ Msps; $f_i = 70$ MHz | - | 35 | - | mA |
| P | power dissipation | ADC1015S125; analog supply only | - | 840 | - | mW |
| | | ADC1015S105; analog supply only | - | 770 | - | mW |
| | | ADC1015S080; analog supply only | - | 635 | - | mW |
| | | ADC1015S065; analog supply only | - | 580 | - | mW |
| | | Power-down mode | - | 2 | - | mW |
| | | Standby mode | - | 40 | - | mW |
| Clock inputs: pins CLKP and CLKM | | | | | | |
| LVPECL | | | | | | |
| $V_{i(clk)dif}$ | differential clock input voltage | peak-to-peak | - | 1.6 | - | V |
| SINE wave | | | | | | |
| $V_{i(clk)dif}$ | differential clock input voltage | peak | - | ± 3.0 | - | V |
| LVC MOS | | | | | | |
| V_{IL} | LOW-level input voltage | | - | - | $0.3V_{DDA(3V)}$ | V |
| V_{IH} | HIGH-level input voltage | | $0.7V_{DDA(3V)}$ | - | - | V |
| Logic inputs: pins PWD and \overline{OE} | | | | | | |
| V_{IL} | LOW-level input voltage | | 0 | - | 0.8 | V |
| V_{IH} | HIGH-level input voltage | | 2 | - | $V_{DDA(3V)}$ | V |
| I_{IL} | LOW-level input current | | - | 55 | - | μ A |
| I_{IH} | HIGH-level input current | | - | 65 | - | μ A |
| Serial peripheral interface: pins CS, SDIO/ODS, SCLK/DFS | | | | | | |
| V_{IL} | LOW-level input voltage | | 0 | - | $0.3V_{DDA(3V)}$ | V |
| V_{IH} | HIGH-level input voltage | | $0.7V_{DDA(3V)}$ | - | $V_{DDA(3V)}$ | V |

Table 6. Static characteristics^[1] ...continued

| Symbol | Parameter | Conditions | Min | Typ | Max | Unit |
|---|-----------------------------|--|---------------------|-------------------------|---------------------|------|
| I _{IL} | LOW-level input current | | -10 | - | +10 | μA |
| I _{IH} | HIGH-level input current | | -50 | - | +50 | μA |
| C _I | input capacitance | | - | 4 | - | pF |
| Digital outputs, CMOS mode: pins D9 to D0, OTR, DAV | | | | | | |
| Output levels, V _{DDO} = 3 V | | | | | | |
| V _{OL} | LOW-level output voltage | | OGND | - | 0.2V _{DDO} | V |
| V _{OH} | HIGH-level output voltage | | 0.8V _{DDO} | - | V _{DDO} | V |
| C _O | output capacitance | high impedance; OE = HIGH | - | 3 | - | pF |
| Output levels, V _{DDO} = 1.8 V | | | | | | |
| V _{OL} | LOW-level output voltage | | OGND | - | 0.2V _{DDO} | V |
| V _{OH} | HIGH-level output voltage | | 0.8V _{DDO} | - | V _{DDO} | V |
| Digital outputs, LVDS mode: pins D8_D9_P to D0_D1_P, D8_D9_M to D0_D1_M, DAVP and DAVM | | | | | | |
| Output levels, V _{DDO} = 3 V only, R _{load} = 100 Ω | | | | | | |
| V _{O(offset)} | output offset voltage | output buffer current set to 3.5 mA | - | 1.2 | - | V |
| V _{O(dif)} | differential output voltage | output buffer current set to 3.5 mA | - | 350 | - | mV |
| C _O | output capacitance | | - | 3 | - | pF |
| Analog inputs: pins INP and INM | | | | | | |
| I _I | input current | | -5 | - | +5 | μA |
| R _I | input resistance | | - | 550 | - | Ω |
| C _I | input capacitance | | - | 1.3 | - | pF |
| V _{I(cm)} | common-mode input voltage | V _{INP} = V _{INM} | 0.9 | 1.5 | 2 | V |
| B _I | input bandwidth | | - | 600 | - | MHz |
| V _{I(dif)} | differential input voltage | peak-to-peak | 1 | | 2 | V |
| Common mode output voltage: pin VCM | | | | | | |
| V _{O(cm)} | common-mode output voltage | | - | 0.5V _{DDA(3V)} | - | V |
| I _{O(cm)} | common-mode output current | | - | 4 | - | mA |
| I/O reference voltage: pin VREF | | | | | | |
| V _{VREF} | voltage on pin VREF | output | - | 0.5 to 1 | - | V |
| | | input | 0.5 | - | 1 | V |
| Accuracy | | | | | | |
| INL | integral non-linearity | | -0.4 | ±0.07 | +0.4 | LSB |
| DNL | differential non-linearity | guaranteed no missing codes | -0.06 | ±0.04 | +0.06 | LSB |
| E _{offset} | offset error | | - | ±2 | - | mV |
| E _G | gain error | | - | ±0.5 | - | %FS |

Table 6. Static characteristics^[1] ...continued

| Symbol | Parameter | Conditions | Min | Typ | Max | Unit |
|---------------|------------------------------|----------------------------------|-----|-----|-----|------|
| Supply | | | | | | |
| PSRR | power supply rejection ratio | 200 mV (p-p) on $V_{DDA(3V)}$ | - | -54 | - | dBc |

[1] Typical values measured at $V_{DDA(3V)} = 3\text{ V}$, $V_{DDO} = 1.8\text{ V}$, $V_{DDA(5V)} = 5\text{ V}$; $T_{amb} = 25\text{ °C}$ and $C_L = 5\text{ pF}$; minimum and maximum values are across the full temperature range $T_{amb} = -40\text{ °C}$ to $+85\text{ °C}$ at $V_{DDA(3V)} = 3\text{ V}$, $V_{DDO} = 1.8\text{ V}$, $V_{DDA(5V)} = 5\text{ V}$, $V_{INP} - V_{INM} = -1\text{ dBFS}$; internal reference mode; applied to CMOS and LVDS interface; unless otherwise specified.

10. Dynamic characteristics

10.1 Dynamic characteristics

Table 7. Dynamic characteristics^[1]

| Symbol | Parameter | Conditions | ADC1015S065 | | | ADC1015S080 | | | ADC1015S105 | | | ADC1015S125 | | | Unit |
|---------------------------------|-----------------------------|-----------------|-------------|------|-----|-------------|------|-----|-------------|------|-----|-------------|------|-----|------|
| | | | Min | Typ | Max | Min | Typ | Max | Min | Typ | Max | Min | Typ | Max | |
| Analog signal processing | | | | | | | | | | | | | | | |
| α_{2H} | second harmonic level | $f_i = 3$ MHz | - | 87 | - | - | 87 | - | - | 89 | - | - | 91 | - | dBc |
| | | $f_i = 30$ MHz | - | 86 | - | - | 86 | - | - | 89 | - | - | 90 | - | dBc |
| | | $f_i = 70$ MHz | - | 85 | - | - | 85 | - | - | 87 | - | - | 88 | - | dBc |
| | | $f_i = 170$ MHz | - | 82 | - | - | 82 | - | - | 84 | - | - | 86 | - | dBc |
| α_{3H} | third harmonic level | $f_i = 3$ MHz | - | 86 | - | - | 86 | - | - | 88 | - | - | 90 | - | dBc |
| | | $f_i = 30$ MHz | - | 85 | - | - | 85 | - | - | 88 | - | - | 89 | - | dBc |
| | | $f_i = 70$ MHz | - | 84 | - | - | 84 | - | - | 86 | - | - | 87 | - | dBc |
| | | $f_i = 170$ MHz | - | 81 | - | - | 81 | - | - | 83 | - | - | 85 | - | dBc |
| THD | total harmonic distortion | $f_i = 3$ MHz | - | 83 | - | - | 83 | - | - | 85 | - | - | 87 | - | dBc |
| | | $f_i = 30$ MHz | - | 82 | - | - | 82 | - | - | 85 | - | - | 86 | - | dBc |
| | | $f_i = 70$ MHz | - | 81 | - | - | 81 | - | - | 83 | - | - | 84 | - | dBc |
| | | $f_i = 170$ MHz | - | 78 | - | - | 78 | - | - | 80 | - | - | 82 | - | dBc |
| ENOB | effective number of bits | $f_i = 3$ MHz | - | 9.9 | - | - | 9.9 | - | - | 9.9 | - | - | 9.9 | - | bits |
| | | $f_i = 30$ MHz | - | 9.9 | - | - | 9.9 | - | - | 9.9 | - | - | 9.9 | - | bits |
| | | $f_i = 70$ MHz | - | 9.9 | - | - | 9.9 | - | - | 9.9 | - | - | 9.9 | - | bits |
| | | $f_i = 170$ MHz | - | 9.9 | - | - | 9.9 | - | - | 9.9 | - | - | 9.9 | - | bits |
| SNR | signal-to-noise ratio | $f_i = 3$ MHz | - | 61.7 | - | - | 61.7 | - | - | 61.6 | - | - | 61.6 | - | dBFS |
| | | $f_i = 30$ MHz | - | 61.6 | - | - | 61.6 | - | - | 61.6 | - | - | 61.6 | - | dBFS |
| | | $f_i = 70$ MHz | - | 61.6 | - | - | 61.6 | - | - | 61.5 | - | - | 61.5 | - | dBFS |
| | | $f_i = 170$ MHz | - | 61.5 | - | - | 61.5 | - | - | 61.5 | - | - | 61.5 | - | dBFS |
| SFDR | spurious-free dynamic range | $f_i = 3$ MHz | - | 86 | - | - | 86 | - | - | 88 | - | - | 90 | - | dBc |
| | | $f_i = 30$ MHz | - | 85 | - | - | 85 | - | - | 88 | - | - | 89 | - | dBc |
| | | $f_i = 70$ MHz | - | 84 | - | - | 84 | - | - | 86 | - | - | 87 | - | dBc |
| | | $f_i = 170$ MHz | - | 81 | - | - | 81 | - | - | 83 | - | - | 85 | - | dBc |

Table 7. Dynamic characteristics^[1] ...continued

| Symbol | Parameter | Conditions | ADC1015S065 | | | ADC1015S080 | | | ADC1015S105 | | | ADC1015S125 | | | Unit |
|--------|----------------------------|-------------------------|-------------|-----|-----|-------------|-----|-----|-------------|-----|-----|-------------|-----|-----|------|
| | | | Min | Typ | Max | Min | Typ | Max | Min | Typ | Max | Min | Typ | Max | |
| IMD | Intermodulation distortion | $f_i = 3 \text{ MHz}$ | - | 89 | - | - | 89 | - | - | 92 | - | - | 93 | - | dBc |
| | | $f_i = 30 \text{ MHz}$ | - | 88 | - | - | 88 | - | - | 92 | - | - | 92 | - | dBc |
| | | $f_i = 70 \text{ MHz}$ | - | 87 | - | - | 87 | - | - | 90 | - | - | 90 | - | dBc |
| | | $f_i = 170 \text{ MHz}$ | - | 84 | - | - | 85 | - | - | 87 | - | - | 88 | - | dBc |

[1] Typical values measured at $V_{DDA(3V)} = 3 \text{ V}$, $V_{DDO} = 1.8 \text{ V}$, $V_{DDA(5V)} = 5 \text{ V}$; $T_{\text{amb}} = 25 \text{ }^\circ\text{C}$ and $C_L = 5 \text{ pF}$; minimum and maximum values are across the full temperature range $T_{\text{amb}} = -40 \text{ }^\circ\text{C}$ to $+85 \text{ }^\circ\text{C}$ at $V_{DDA(3V)} = 3 \text{ V}$, $V_{DDO} = 1.8 \text{ V}$, $V_{DDA(5V)} = 5 \text{ V}$, $V_{\text{INP}} - V_{\text{INM}} = -1 \text{ dBFS}$; internal reference mode; applied to CMOS and LVDS interface; unless otherwise specified.

10.2 Clock and digital output timing

Table 8. Clock and digital output timing characteristics^[1]

| Symbol | Parameter | Conditions | ADC1410S065 | | | ADC1410S080 | | | ADC1410S105 | | | ADC1410S125 | | | Unit |
|---|---------------------|------------|-------------|------|------|-------------|------|------|-------------|------|------|-------------|------|------|--------------|
| | | | Min | Typ | Max | Min | Typ | Max | Min | Typ | Max | Min | Typ | Max | |
| Clock timing input: pins CLKP and CLKM | | | | | | | | | | | | | | | |
| f _{clk} | clock frequency | | 40 | - | 65 | 60 | - | 80 | 75 | - | 105 | 100 | - | 125 | MHz |
| t _{lat(data)} | data latency time | | - | 13.5 | - | - | 13.5 | - | - | 13.5 | - | - | 13.5 | - | clock cycles |
| δ _{clk} | clock duty cycle | DCS_EN = 1 | 30 | 50 | 70 | 30 | 50 | 70 | 30 | 50 | 70 | 30 | 50 | 70 | % |
| | | DCS_EN = 0 | 45 | 50 | 55 | 45 | 50 | 55 | 45 | 50 | 55 | 45 | 50 | 55 | % |
| t _{d(s)} | sampling delay time | | - | 0.8 | - | - | 0.8 | - | - | 0.8 | - | - | 0.8 | - | ns |
| t _{wake} | wake-up time | | - | 76 | - | - | 76 | - | - | 76 | - | - | 76 | - | μs |
| CMOS Mode timing output: pins D9 to D0 and DAV | | | | | | | | | | | | | | | |
| t _{PD} | propagation delay | DATA | 13.6 | 14.9 | 16.4 | 11.9 | 12.9 | 14.4 | 8.0 | 10.8 | 12.4 | 8.2 | 9.7 | 11.3 | ns |
| | | DAV | - | 4.2 | - | - | 3.6 | - | - | 3.3 | - | - | 3.4 | - | ns |
| t _{su} | set-up time | | - | 12.5 | - | - | 9.8 | - | - | 6.8 | - | - | 5.6 | - | ns |
| t _h | hold time | | - | 3.4 | - | - | 3.3 | - | - | 3.1 | - | - | 2.8 | - | ns |
| t _r | rise time | DATA | [2] 0.39 | - | 2.4 | 0.39 | - | 2.4 | 0.39 | - | 2.4 | 0.39 | - | 2.4 | ns |
| | | DAV | 0.26 | - | 2.4 | 0.26 | - | 2.4 | 0.26 | - | 2.4 | 0.26 | - | 2.4 | ns |
| t _f | fall time | DATA | [2] 0.19 | - | 2.4 | 0.19 | - | 2.4 | 0.19 | - | 2.4 | 0.19 | - | 2.4 | ns |

Table 8. Clock and digital output timing characteristics^[1] ...continued

| Symbol | Parameter | Conditions | ADC1410S065 | | | ADC1410S080 | | | ADC1410S105 | | | ADC1410S125 | | | Unit |
|--|-------------------|------------|---------------------|-----|-----|-------------|-----|-----|-------------|-----|-----|-------------|-----|-----|------|
| | | | Min | Typ | Max | Min | Typ | Max | Min | Typ | Max | Min | Typ | Max | |
| LVDS DDR mode timing output: pins D8_D9_P to D0_D1_P, D8_D9_M to D0_D1_M, DAVP and DAVM | | | | | | | | | | | | | | | |
| t _{PD} | propagation delay | DATA | 3.3 | 5.1 | 7.6 | 2.9 | 4.6 | 7.1 | 2.5 | 4.2 | 6.8 | 2.2 | 4.0 | 6.6 | ns |
| | | DAV | - | 2.8 | - | - | 2.5 | - | - | 2.3 | - | - | 2.2 | - | ns |
| t _{su} | set-up time | | - | 5.4 | - | - | 4.1 | - | - | 2.6 | - | - | 1.9 | - | ns |
| t _h | hold time | | - | 2.2 | - | - | 2.0 | - | - | 1.8 | - | - | 1.7 | - | ns |
| t _r | rise time | DATA | ^[3] 0.5 | - | 5 | 0.5 | - | 5 | 0.5 | - | 5 | 0.5 | - | 5 | ns |
| | | DAV | 0.18 | - | 2.4 | 0.18 | - | 2.4 | 0.18 | - | 2.4 | 0.18 | - | 2.4 | ns |
| t _f | fall time | DATA | ^[3] 0.15 | - | 1.6 | 0.15 | - | 1.6 | 0.15 | - | 1.6 | 0.15 | - | 1.6 | ns |

[1] Typical values measured at V_{DDA(3V)} = 3 V, V_{DDO} = 1.8 V, V_{DDA(5V)} = 5 V; T_{amb} = 25 °C and C_L = 5 pF; minimum and maximum values are across the full temperature range T_{amb} = -40 °C to +85 °C at V_{DDA(3V)} = 3 V, V_{DDO} = 1.8 V, V_{DDA(5V)} = 5 V, V_{INP} - V_{INM} = -1 dBFS; internal reference mode; applied to CMOS and LVDS interface; unless otherwise specified.

[2] Measured between 20 % to 80 % of V_{DDO}.

[3] Rise time measured from -50 mV to +50 mV; fall time measured from +50 mV to -50 mV.

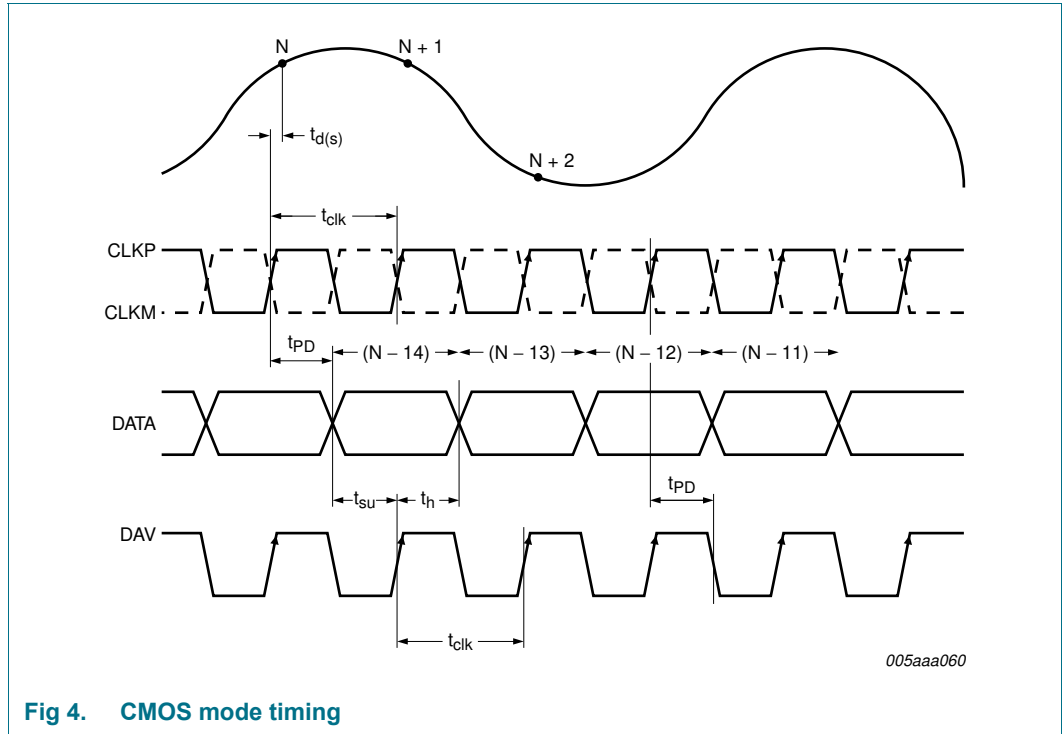

Fig 4. CMOS mode timing

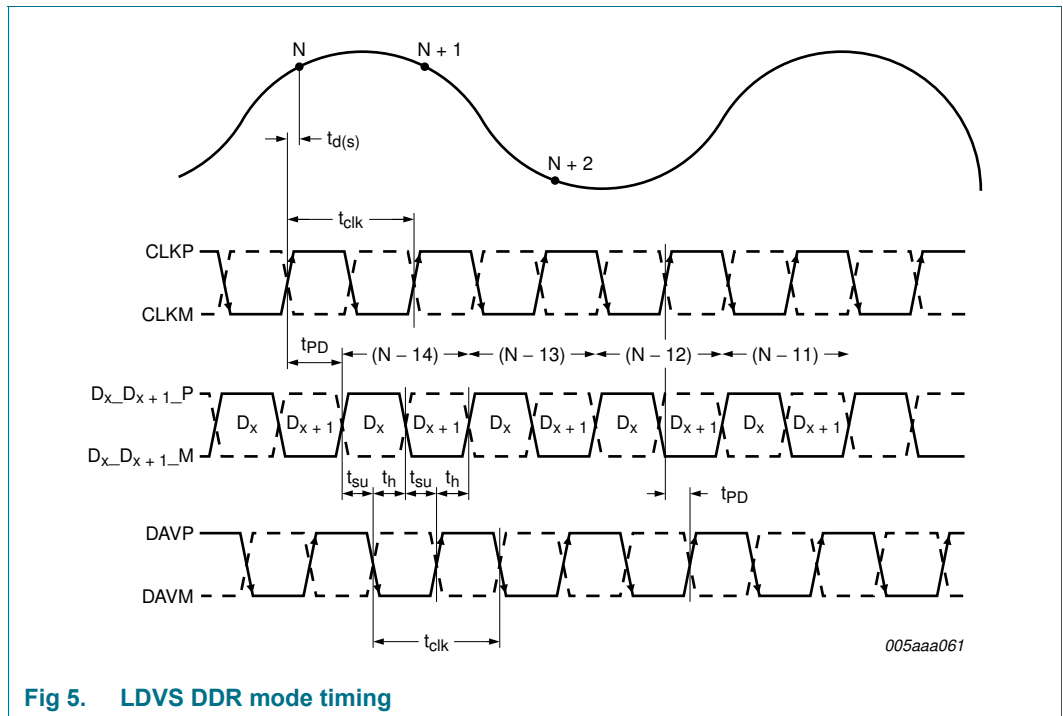

Fig 5. LVDS DDR mode timing

10.3 SPI timings

Table 9. SPI timings characteristics^[1]

| Symbol | Parameter | Conditions | Min | Typ | Max | Unit |
|----------------|-------------------------|------------------------------|-----|-----|-----|------|
| $t_{w(SCLK)}$ | SCLK pulse width | | - | 40 | - | ns |
| $t_{w(SCLKH)}$ | SCLK HIGH pulse width | | - | 16 | - | ns |
| $t_{w(SCLKL)}$ | SCLK LOW pulse width | | - | 16 | - | ns |
| t_{su} | set-up time | data to SCLK HIGH | - | 5 | - | ns |
| | | \overline{CS} to SCLK HIGH | - | 5 | - | ns |
| t_h | hold time | data to SCLK HIGH | - | 2 | - | ns |
| | | \overline{CS} to SCLK HIGH | - | 2 | - | ns |
| $f_{clk(max)}$ | maximum clock frequency | | - | 25 | - | MHz |

[1] Typical values measured at $V_{DDA(3V)} = 3\text{ V}$, $V_{DDO} = 1.8\text{ V}$, $V_{DDA(5V)} = 5\text{ V}$, $T_{amb} = 25\text{ }^\circ\text{C}$ and $C_L = 5\text{ pF}$; minimum and maximum values are across the full temperature range $T_{amb} = -40\text{ }^\circ\text{C}$ to $+85\text{ }^\circ\text{C}$ at $V_{DDA} = 3\text{ V}$, $V_{DDO} = 1.8\text{ V}$.

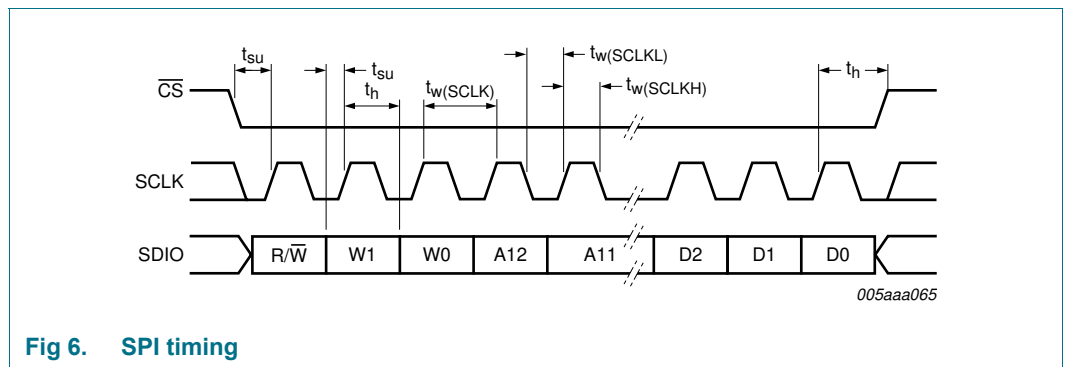
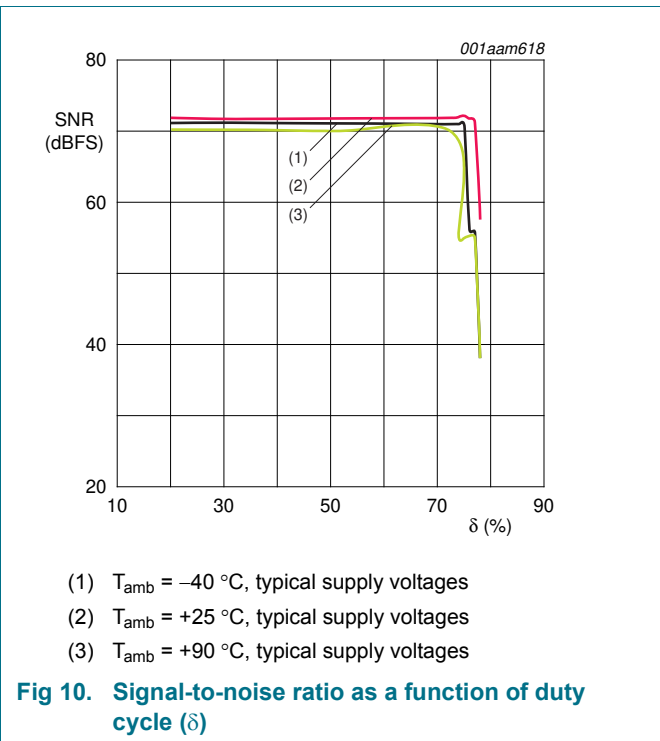
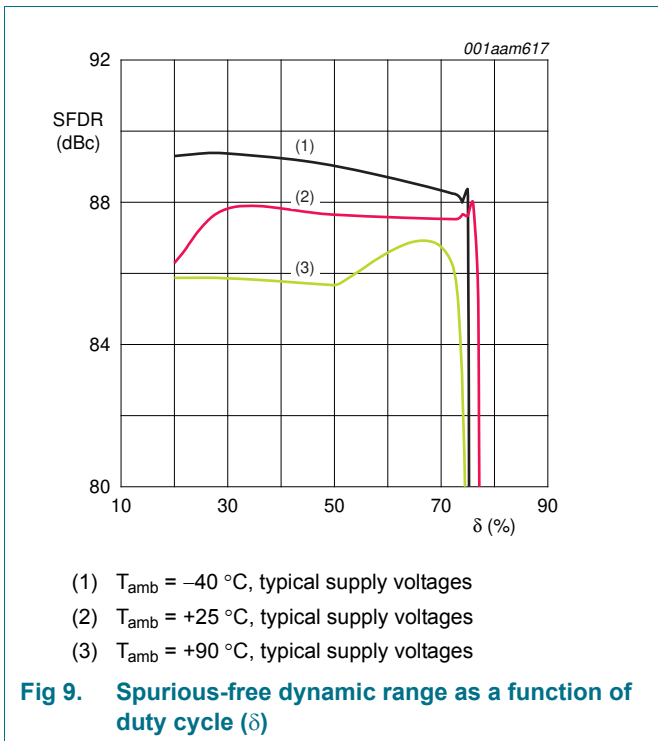
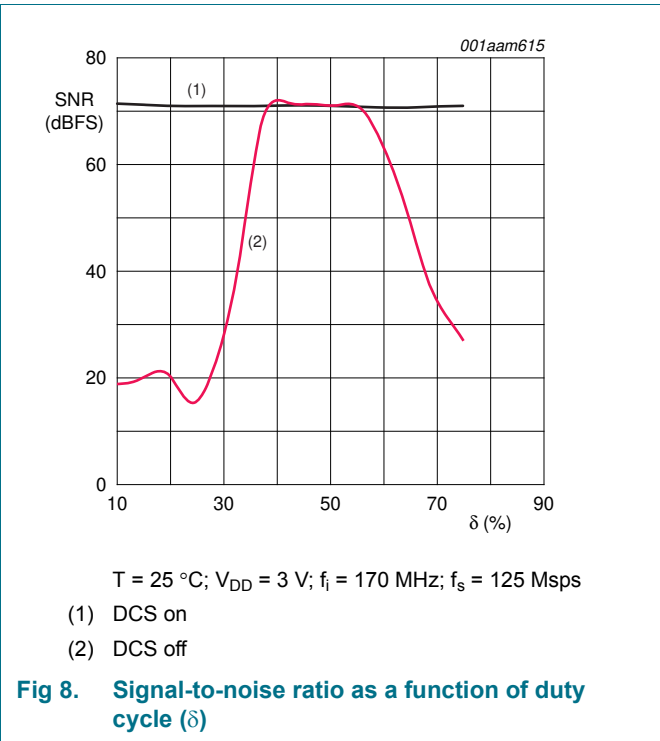
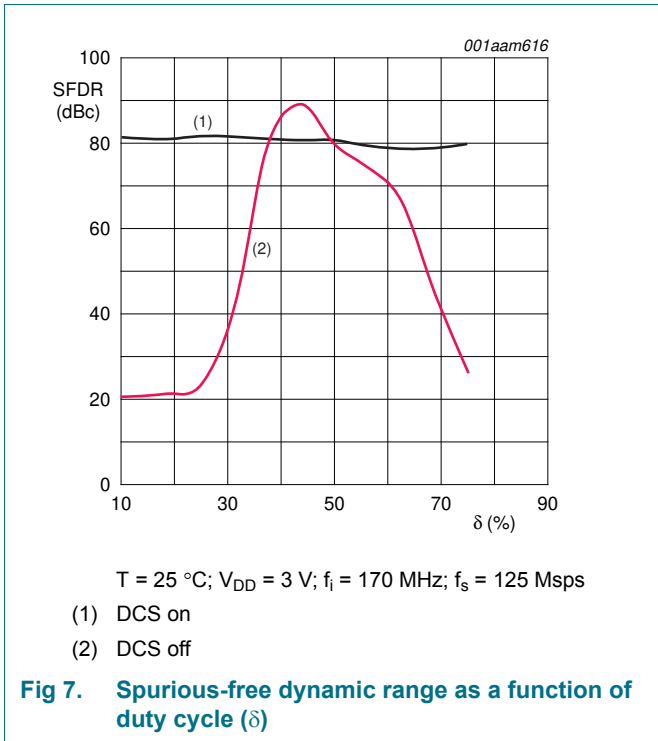

Fig 6. SPI timing

10.4 Typical characteristics



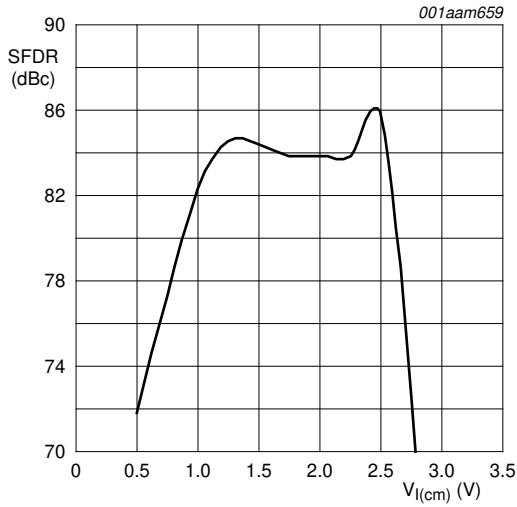

Fig 11. Spurious-free dynamic range as a function of common-mode input voltage ($V_{I(cm)}$)

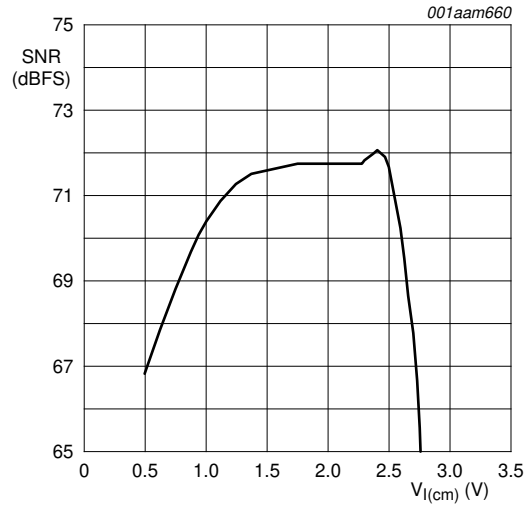

Fig 12. Signal-to-noise ratio as a function of common-mode input voltage ($V_{I(cm)}$)

11. Application information

11.1 Device control

The ADC1015S can be controlled via the Serial Peripheral Interface (SPI) or directly via the I/O pins (Pin control mode).

11.1.1 SPI and Pin control modes

The device enters Pin control mode at power-up, and remains in this mode as long as pin \overline{CS} is held HIGH. In Pin control mode, the SPI pins SDIO, \overline{CS} and SCLK are used as static control pins.

SPI control mode is enabled by forcing pin \overline{CS} LOW. Once SPI control mode has been enabled, the device remains in this mode. The transition from Pin control mode to SPI control mode is illustrated in Figure 13.

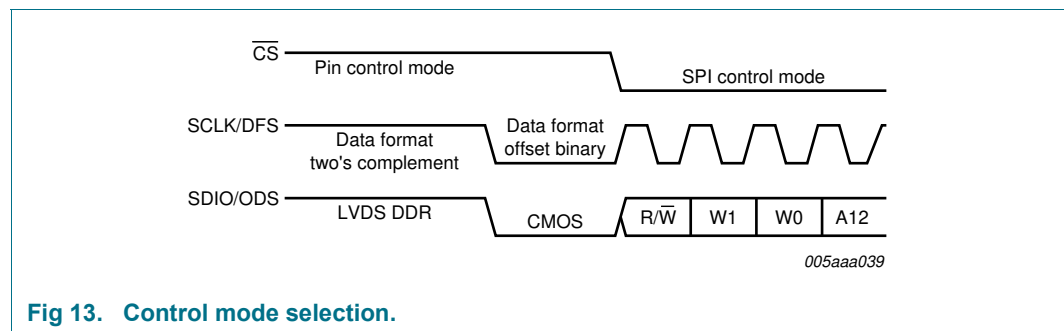

Fig 13. Control mode selection.

When the device enters SPI control mode, the output data standard and data format are determined by the level on pin SDIO as soon as a transition is triggered by a falling edge on \overline{CS} .

11.1.2 Operating mode selection

The active ADC1015S operating mode (Power-up, Power-down or Sleep) can be selected via the SPI interface (see Table 19) or using pins PWD and \overline{OE} in Pin control mode, as described in Table 10.

Table 10. Operating mode selection via pin PWD and \overline{OE}

| Pin PWD | Pin \overline{OE} | Operating mode | Output high-Z |
|---------|---------------------|----------------|---------------|
| 0 | 0 | Power-up | no |
| 0 | 1 | Power-up | yes |
| 1 | 0 | Sleep | yes |
| 1 | 1 | Power-down | yes |

11.1.3 Selecting the output data standard

The output data standard (CMOS or LVDS DDR) can be selected via the SPI interface (see Table 23) or using pin ODS in Pin control mode. LVDS DDR is selected when ODS is HIGH, otherwise CMOS is selected.

11.1.4 Selecting the output data format

The output data format can be selected via the SPI interface (offset binary, two's complement or gray code; see Table 23) or using pin DFS in Pin control mode (offset binary or two's complement). Offset binary is selected when DFS is LOW. When DFS is HIGH, two's complement is selected.

11.2 Analog inputs

11.2.1 Input stage

The analog input of the ADC1015S supports a differential or a single-ended input drive. Optimal performance is achieved using differential inputs. The ADC inputs are internally biased and need to be decoupled.

The full-scale analog input voltage range is configurable between 1 V (p-p) and 2 V (p-p) via a programmable internal reference (see Section 11.3 and Table 21).

The equivalent circuit of the input buffer followed by the Sample and Hold (S/H) input stage, including ElectroStatic Discharge (ESD) protection and circuit and package parasitics, is shown in Figure 14.

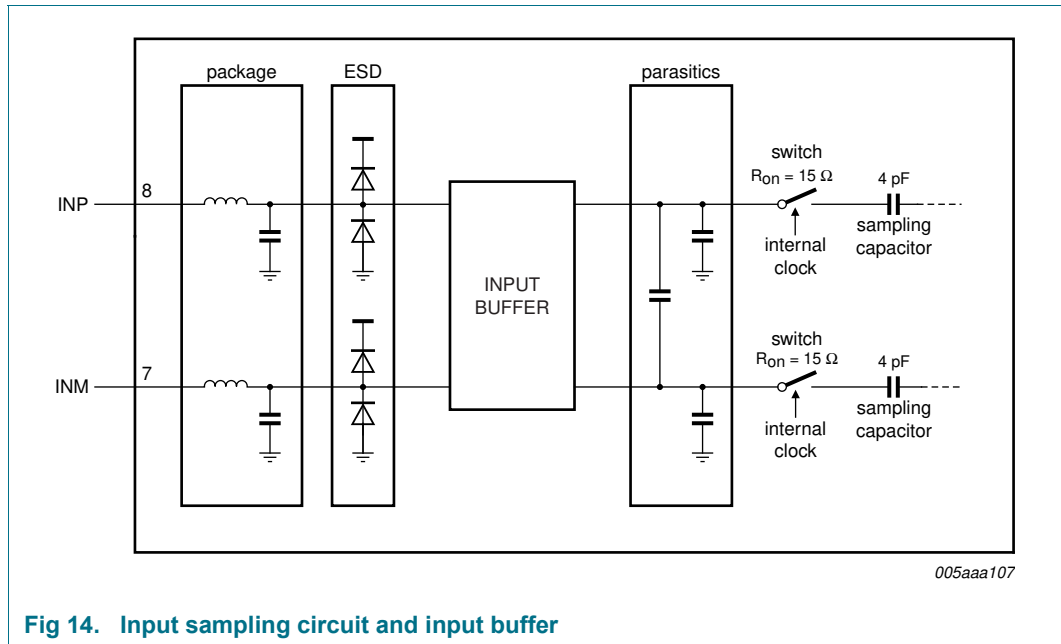

Fig 14. Input sampling circuit and input buffer

The integrated input buffer offers the following advantages:

- The kickback effect is avoided - the charge injection and glitches generated by the S/H input stage are isolated from the input circuitry. So there's no need for additional filtering.
- The input capacitance is very low and constant over a wide frequency range, which makes the ADC1015S easy to drive.

The sample phase occurs when the internal clock (derived from the clock signal on pin CLKP/CLKM) is HIGH. The voltage is then held on the sampling capacitors. When the clock signal goes LOW, the stage enters the hold phase and the voltage information is transmitted to the ADC core.

11.2.2 Transformer

The configuration of the transformer circuit is determined by the input frequency. The configuration shown in Figure 15 would be suitable for a baseband application.

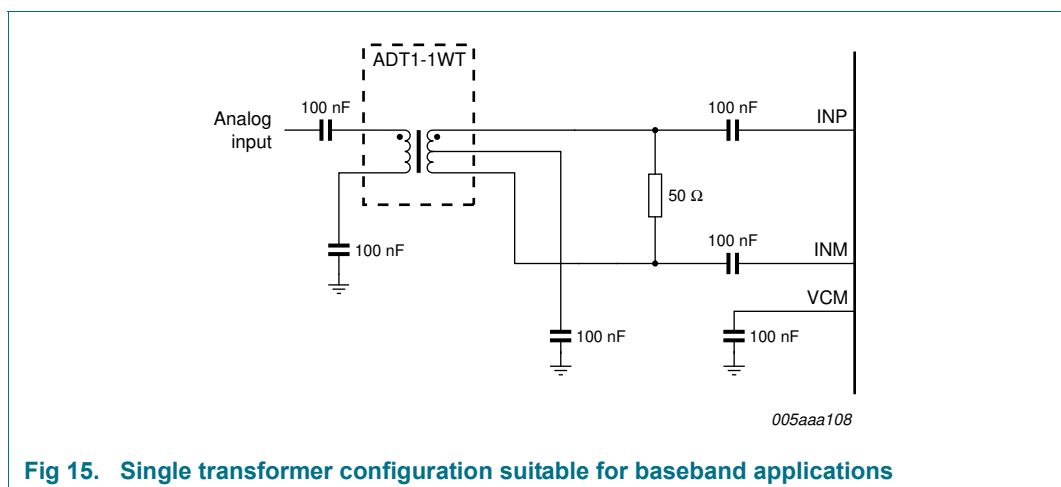
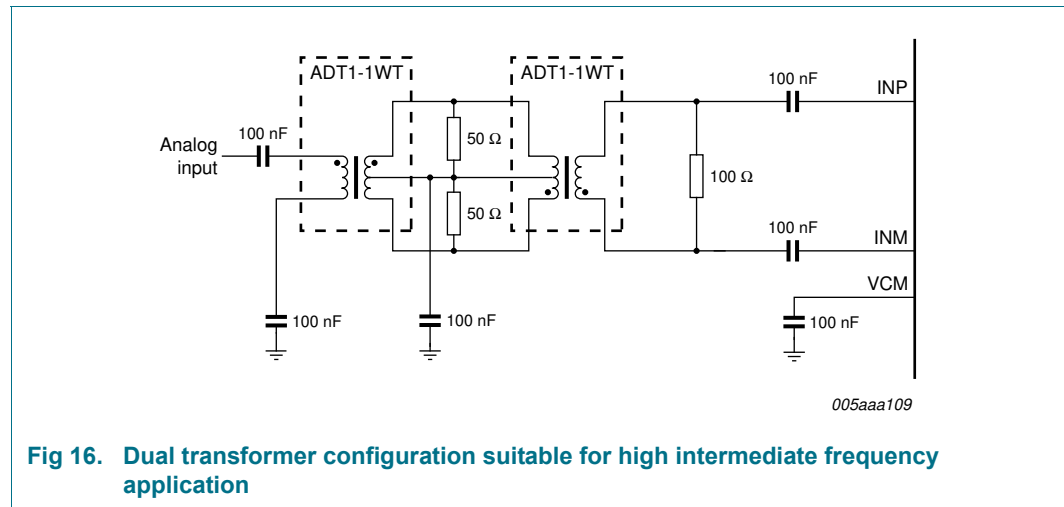

Fig 15. Single transformer configuration suitable for baseband applications

The configuration shown in Figure 16 is recommended for high frequency applications. In both cases, the choice of transformer is a compromise between cost and performance.



11.3 System reference and power management

11.3.1 Internal/external references

The ADC1015S has a stable and accurate built-in internal reference voltage to adjust the ADC full-scale. This reference voltage can be set internally via SPI or with pins VREF and SENSE (programmable in 1 dB steps between 0 dB and -6 dB via control bits INTREF[2:0] when bit INTREF_EN = logic 1; see Table 21). See Figure 18 to Figure 21. The equivalent reference circuit is shown in Figure 17. External reference is also possible by providing a voltage on pin VREF as described in Figure 20.

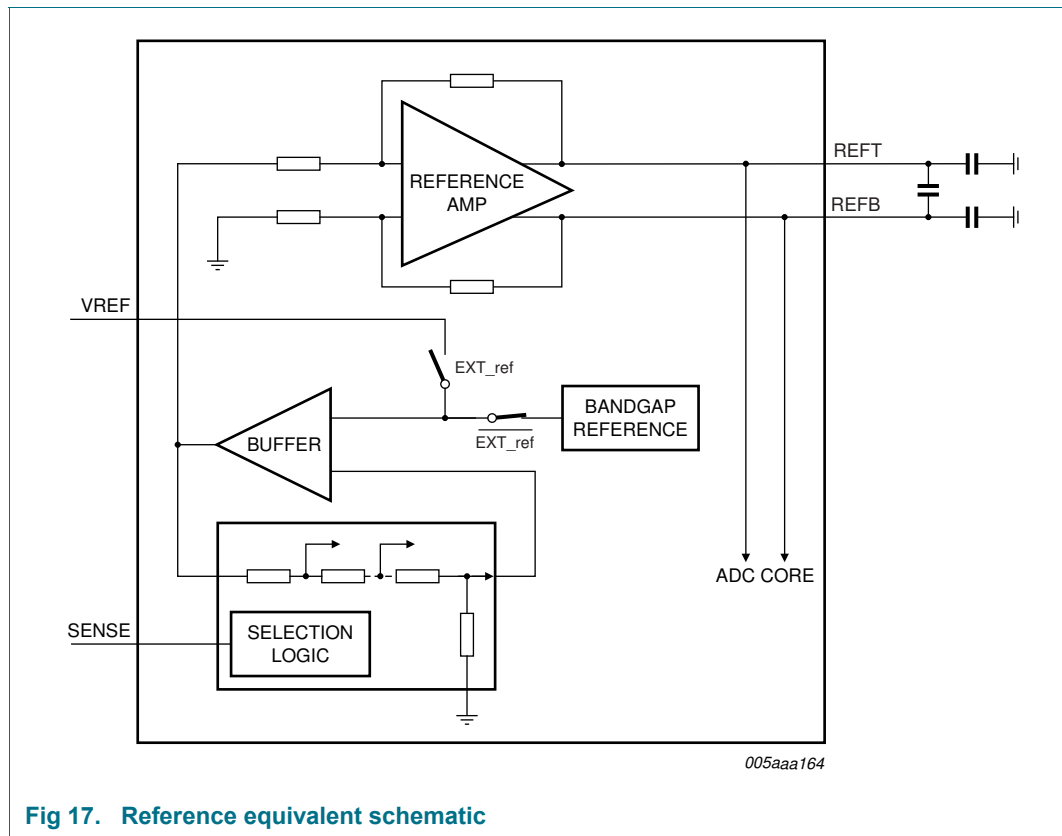

Fig 17. Reference equivalent schematic

If bit INTREF_EN is set to logic 0, the reference voltage is determined either internally or externally as detailed in Table 11.

Table 11. Reference selection

| Selection | SPI bit INTREF_EN | SENSE pin | VREF pin | Full-scale (p-p) |
|------------------------------|-------------------|--|---|------------------|
| internal (Figure 18) | 0 | AGND | 330 pF capacitor to AGND | 2 V |
| internal (Figure 19) | 0 | pin VREF connected to pin SENSE and via a 330 pF capacitor to AGND | | 1 V |
| external (Figure 20) | 0 | V _{DDA(3V)} | external voltage between 0.5 V and 1 V ^[1] | 1 V to 2 V |
| internal via SPI (Figure 21) | 1 | pin VREF connected to pin SENSE and via 330 pF capacitor to AGND | | 1 V to 2 V |

[1] The voltage on pin VREF is doubled internally to generate the internal reference voltage.

Figure 18 to Figure 21 illustrate how to connect the SENSE and VREF pins to select the required reference voltage source.

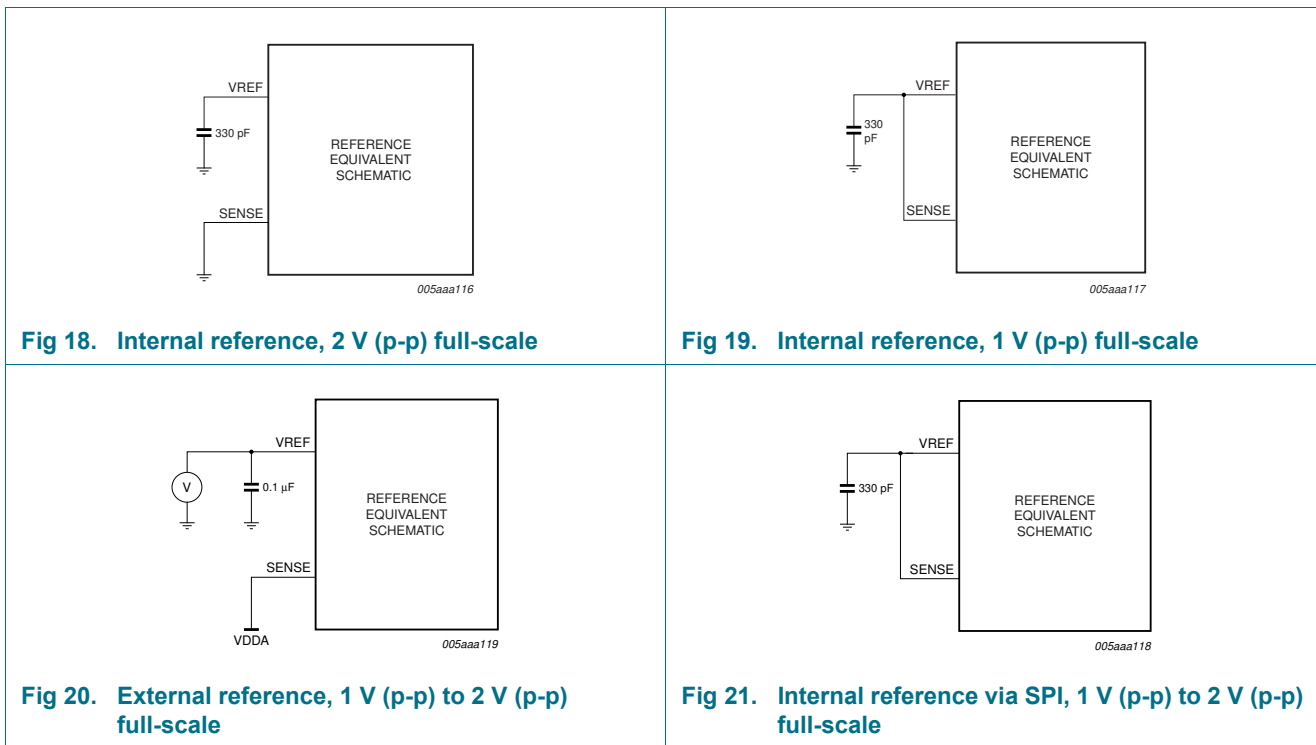

11.3.2 Programmable full-scale

The full-scale is programmable between 1 V (peak-to-peak) to 2 V (peak-to-peak) (see Table 12).

Table 12. Reference SPI gain control

| INTREF | Gain | Full-scale (p-p) |
|--------|----------|------------------|
| 000 | 0 dB | 2 V |
| 001 | -1 dB | 1.78 V |
| 010 | -2 dB | 1.59 V |
| 011 | -3 dB | 1.42 V |
| 100 | -4 dB | 1.26 V |
| 101 | -5 dB | 1.12 V |
| 110 | -6 dB | 1 V |
| 111 | reserved | x |

11.3.3 Common-mode output voltage ($V_{O(cm)}$)

A 0.1 μ F filter capacitor should be connected between pin VCM and ground.

11.3.4 Biasing

The common-mode input voltage ($V_{I(cm)}$) on pins INP and INM is set internally. The input buffer bias current can be set to one of three levels (high, medium or low) via the SPI (see Table 22).

11.4 Clock input

11.4.1 Drive modes

The ADC1015S can be driven differentially (LVPECL). It can also be driven by a single-ended Low Voltage Complementary Metal Oxide Semiconductor (LVCMOS) signal connected to pin CLKP (pin CLKM should be connected to ground via a capacitor) or CLKM (pin CLKP should be connected to ground via a capacitor).

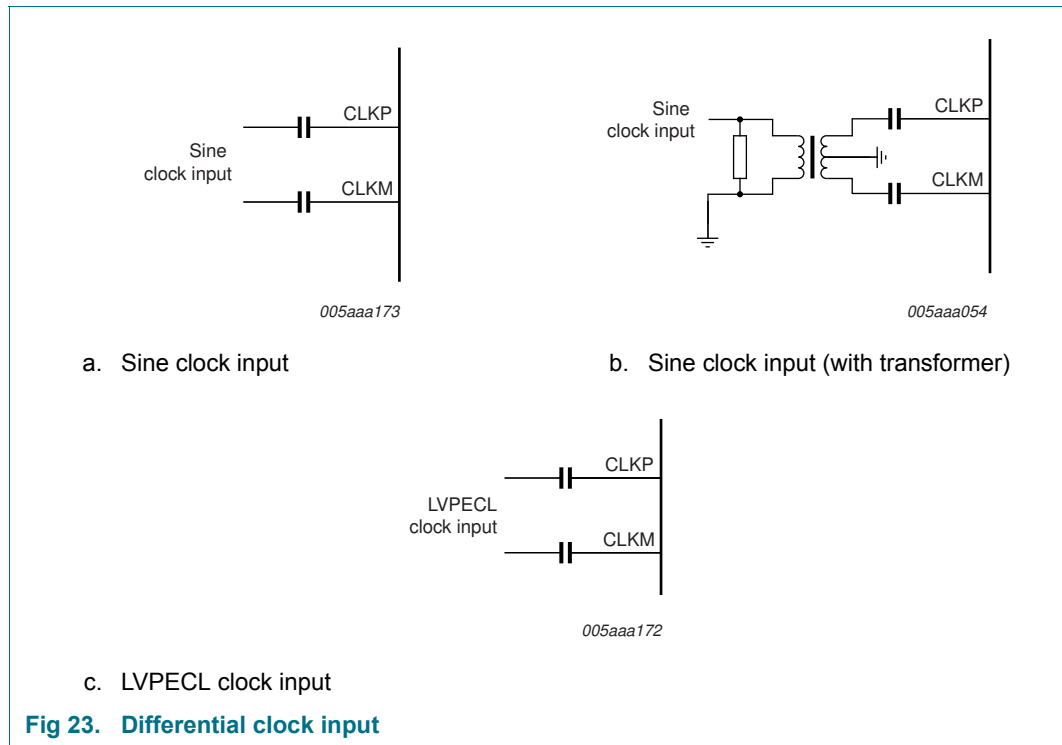
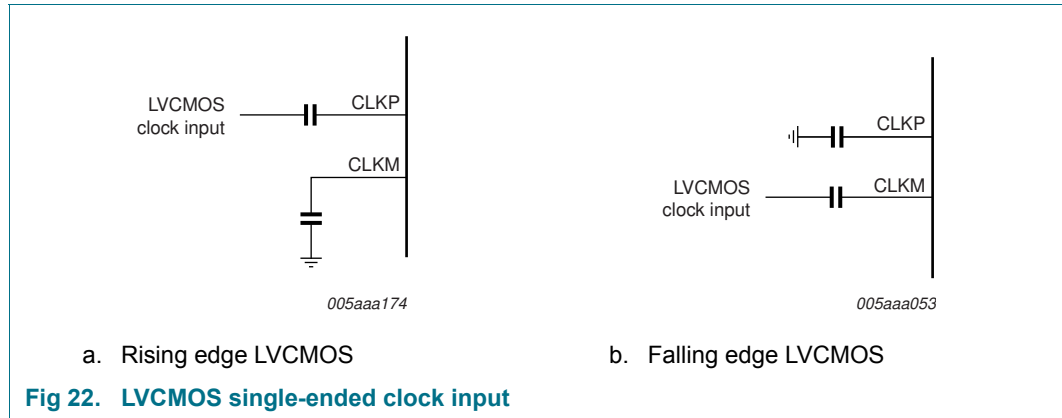

11.4.2 Equivalent input circuit

The equivalent circuit of the input clock buffer is shown in Figure 24. The common-mode voltage of the differential input stage is set via internal 5 k Ω resistors.

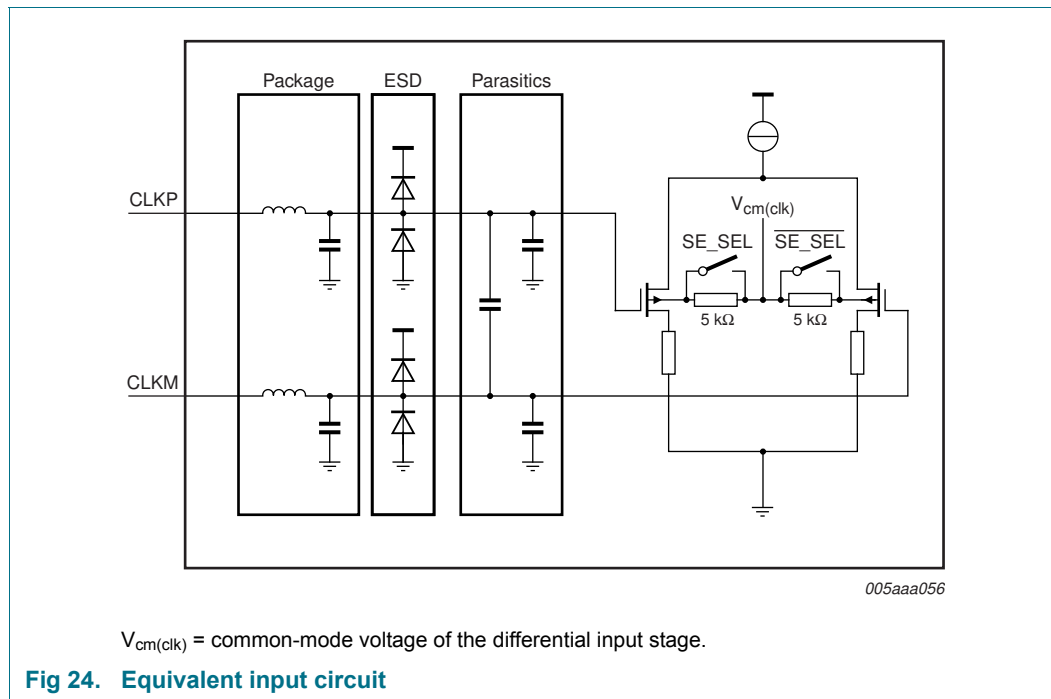

Single-ended or differential clock inputs can be selected via the SPI interface (see Table 20). If single-ended is enabled, the input pin (CLKM or CLKP) is selected via control bit SE_SEL.

If single-ended is implemented without setting bit SE_SEL to the appropriate value, the unused pin should be connected to ground via a capacitor.

11.4.3 Duty cycle stabilizer

The duty cycle stabilizer can improve the overall performance of the ADC by compensating the duty cycle of the input clock signal. When the duty cycle stabilizer is active (bit DCS_EN = logic 1; see Table 20), the circuit can handle signals with duty cycles of between 30 % and 70 % (typical). When the duty cycle stabilizer is disabled (DCS_EN = logic 0), the input clock signal should have a duty cycle of between 45 % and 55 %.

11.4.4 Clock input divider

The ADC1015S contains an input clock divider that divides the incoming clock by a factor of 2 (when bit CLKDIV = logic 1; see Table 20). This feature allows the user to deliver a higher clock frequency with better jitter performance, leading to a better SNR result once acquisition has been performed.

11.5 Digital outputs

11.5.1 Digital output buffers: CMOS mode

The digital output buffers can be configured as CMOS by setting bit LVDS_CMOS to logic 0 (see Table 23).

Each digital output has a dedicated output buffer. The equivalent circuit of the CMOS digital output buffer is shown in Figure 25. The buffer is powered by a separate OGND/V_{DDO} to ensure 1.8 V to 3.3 V compatibility and is isolated from the ADC core. Each buffer can be loaded by a maximum of 10 pF.

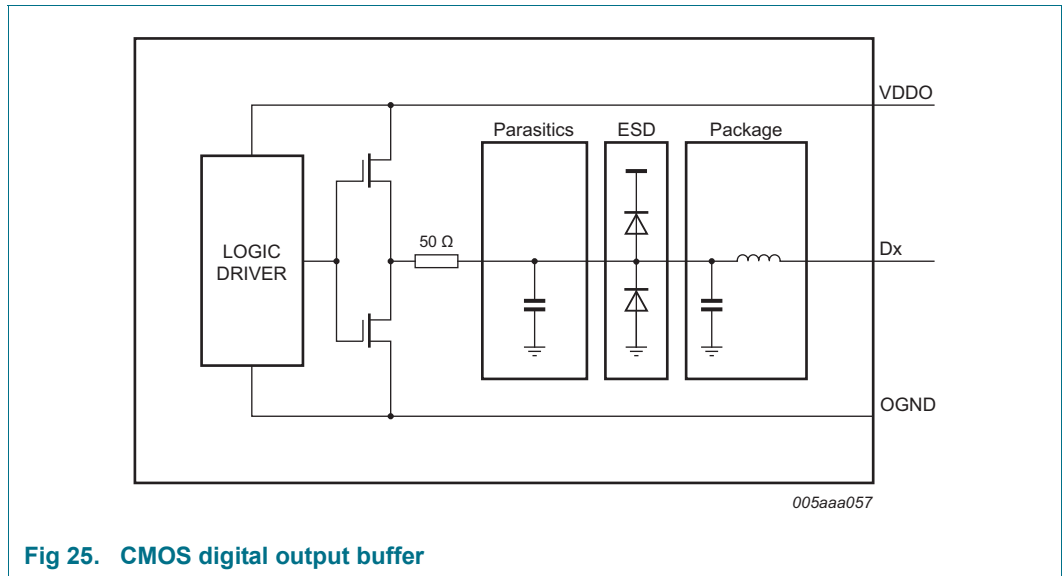

Fig 25. CMOS digital output buffer

The output resistance is 50 Ω and is the combination of the an internal resistor and the equivalent output resistance of the buffer. There is no need for an external damping resistor. The drive strength of both data and DAV buffers can be programmed via the SPI in order to adjust the rise and fall times of the output digital signals (see Table 30):