



Chipsmall Limited consists of a professional team with an average of over 10 year of expertise in the distribution of electronic components. Based in Hongkong, we have already established firm and mutual-benefit business relationships with customers from,Europe,America and south Asia,supplying obsolete and hard-to-find components to meet their specific needs.

With the principle of "Quality Parts,Customers Priority,Honest Operation,and Considerate Service",our business mainly focus on the distribution of electronic components. Line cards we deal with include Microchip,ALPS,ROHM,Xilinx,Pulse,ON,Everlight and Freescale. Main products comprise IC,Modules,Potentiometer,IC Socket,Relay,Connector.Our parts cover such applications as commercial,industrial, and automotives areas.

We are looking forward to setting up business relationship with you and hope to provide you with the best service and solution. Let us make a better world for our industry!



Contact us

Tel: +86-755-8981 8866 Fax: +86-755-8427 6832

Email & Skype: info@chipsmall.com Web: www.chipsmall.com

Address: A1208, Overseas Decoration Building, #122 Zhenhua RD., Futian, Shenzhen, China



ADC1412D series

Dual 14-bit ADC; 65 Msps, 80 Msps, 105 Msps or 125 Msps;
CMOS or LVDS DDR digital outputs

Rev. 05 — 2 July 2012

Product data sheet

1. General description

The ADC1412D is a dual channel 14-bit Analog-to-Digital Converter (ADC) optimized for high dynamic performance and low power consumption at sample rates up to 125 Msps. Pipelined architecture and output error correction ensure the ADC1412D is accurate enough to guarantee zero missing codes over the entire operating range. Supplied from a single 3 V source, it can handle output logic levels from 1.8 V to 3.3 V in Complementary Metal Oxide Semiconductor (CMOS) mode because of a separate digital output supply. It supports the Low Voltage Differential Signalling (LVDS) Double Data Rate (DDR) output standard. An integrated Serial Peripheral Interface (SPI) allows the user to easily configure the ADC. The device also includes an programmable full-scale SPI to allow a flexible input voltage range of 1 V (p-p) to 2 V (p-p). With excellent dynamic performance from the baseband to input frequencies of 170 MHz or more, the ADC1412D is ideal for use in communications, imaging and medical applications.

2. Features and benefits

- SNR, 72.1 dBFS
- SFDR, 86 dBc
- Sample rate up to 125 Msps
- Clock input divided by 2 to reduce jitter contribution
- Single 3 V supply
- Flexible input voltage range: 1 V to 2 V (p-p)
- CMOS or LVDS DDR digital outputs
- Pin and software compatible with ADC1212D series and ADC1112D125
- Input bandwidth, 600 MHz
- Power dissipation, 855 mW at 80 Msps
- Serial Peripheral Interface (SPI)
- Duty cycle stabilizer
- Fast Out-of-Range (OTR) detection
- Offset binary, two's complement, gray code
- Power-down and Sleep modes
- HVQFN64 package

3. Applications

- Wireless and wired broadband communications
- Spectral analysis
- Ultrasound equipment
- Portable instrumentation
- Imaging systems
- Software defined radio



4. Ordering information

Table 1. Ordering information

Type number	f _s (MSPs)	Package		Version
		Name	Description	
ADC1412D125HN-C1	125	HVQFN64	plastic thermal enhanced very thin quad flat package; no leads; 64 terminals; body 9 × 9 × 0.85 mm	SOT804-3
ADC1412D105HN-C1	105	HVQFN64	plastic thermal enhanced very thin quad flat package; no leads; 64 terminals; body 9 × 9 × 0.85 mm	SOT804-3
ADC1412D080HN-C1	80	HVQFN64	plastic thermal enhanced very thin quad flat package; no leads; 64 terminals; body 9 × 9 × 0.85 mm	SOT804-3
ADC1412D065HN-C1	65	HVQFN64	plastic thermal enhanced very thin quad flat package; no leads; 64 terminals; body 9 × 9 × 0.85 mm	SOT804-3

5. Block diagram

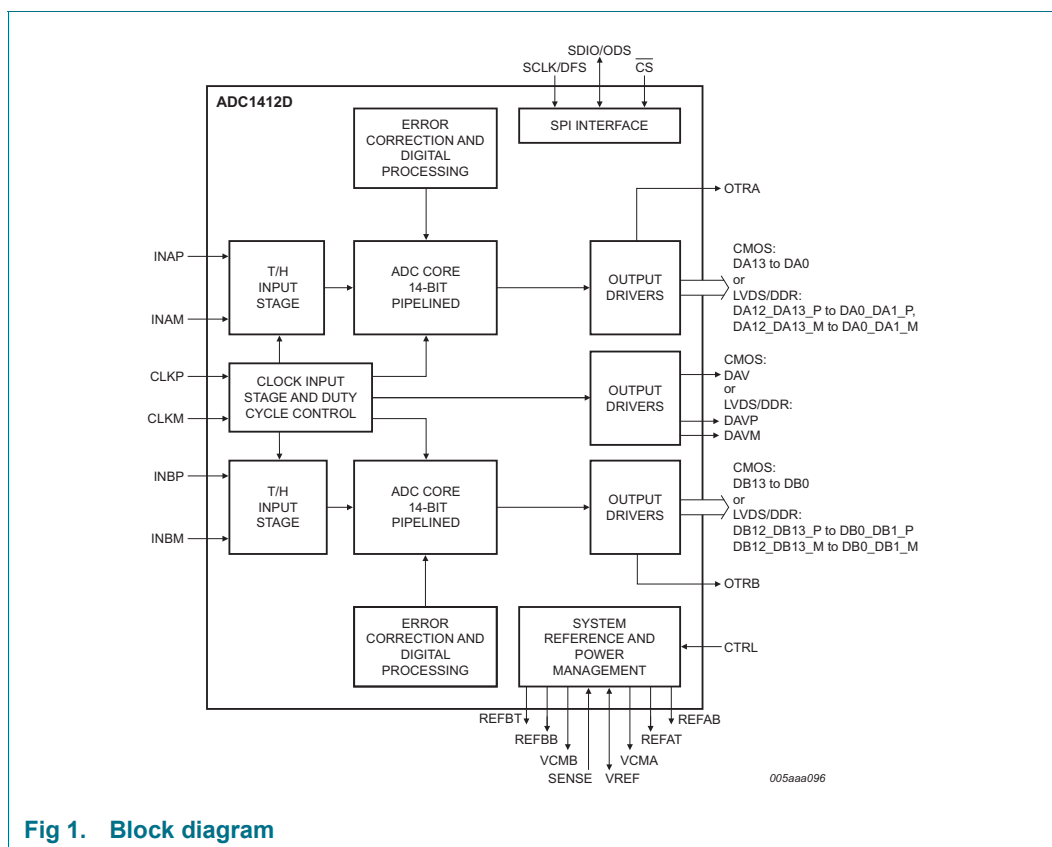

6. Pinning information

6.1 CMOS outputs selected

6.1.1 Pinning

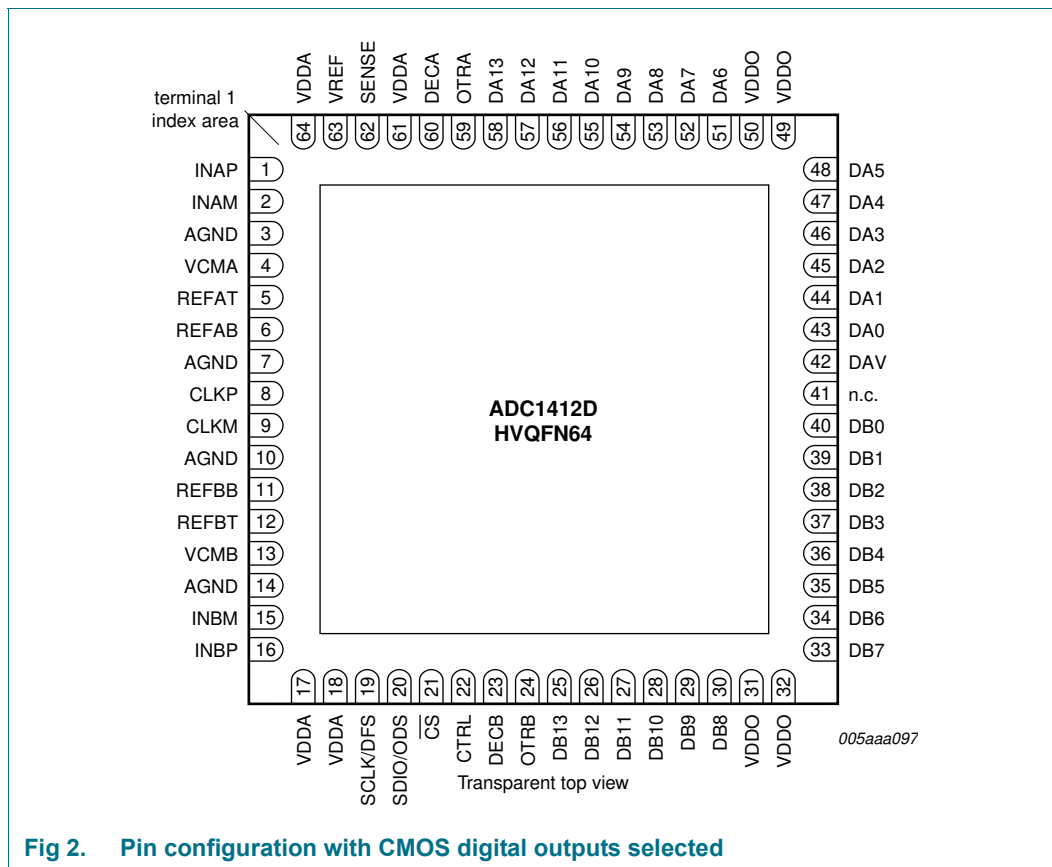

Fig 2. Pin configuration with CMOS digital outputs selected

6.1.2 Pin description

Table 2. Pin description (CMOS digital outputs)

Symbol	Pin	Type ^[1]	Description
INAP	1	I	analog input; channel A
INAM	2	I	complementary analog input; channel A
AGND	3	G	analog ground
VCMA	4	O	common-mode output voltage; channel A
REFAT	5	O	top reference; channel A
REFAB	6	O	bottom reference; channel A
AGND	7	G	analog ground
CLKP	8	I	clock input
CLKM	9	I	complementary clock input
AGND	10	G	analog ground
REFBB	11	O	bottom reference; channel B
REFBT	12	O	top reference; channel B

Table 2. Pin description (CMOS digital outputs) ...continued

Symbol	Pin	Type ^[1]	Description
VCMB	13	O	common-mode output voltage; channel B
AGND	14	G	analog ground
INBM	15	I	complementary analog input; channel B
INBP	16	I	analog input; channel B
VDDA	17	P	analog power supply
VDDA	18	P	analog power supply
SCLK/DFS	19	I	SPI clock/data format select
SDIO/ODS	20	I/O	SPI data input/output/output data standard
$\overline{\text{CS}}$	21	I	SPI chip select, active LOW
CTRL	22	I	control mode select
DECB	23	O	regulator decoupling node; channel B
OTRB	24	O	out of range; channel B
DB13	25	O	data output bit 13 (Most Significant Bit (MSB)); channel B
DB12	26	O	data output bit 12; channel B
DB11	27	O	data output bit 11; channel B
DB10	28	O	data output bit 10; channel B
DB9	29	O	data output bit 9; channel B
DB8	30	O	data output bit 8; channel B
VDDO	31	P	output power supply
VDDO	32	P	output power supply
DB7	33	O	data output bit 7; channel B
DB6	34	O	data output bit 6; channel B
DB5	35	O	data output bit 5; channel B
DB4	36	O	data output bit 4; channel B
DB3	37	O	data output bit 3; channel B
DB2	38	O	data output bit 2; channel B
DB1	39	O	data output bit 1; channel B
DB0	40	O	data output bit 0 (Least Significant Bit (LSB)); channel B
n.c.	41	-	not connected
DAV	42	O	data valid output clock
DA0	43	O	data output bit 0 (LSB); channel A
DA1	44	O	data output bit 1; channel A
DA2	45	O	data output bit 2; channel A
DA3	46	O	data output bit 3; channel A
DA4	47	O	data output bit 4; channel A
DA5	48	O	data output bit 5; channel A
VDDO	49	P	output power supply
VDDO	50	P	output power supply
DA6	51	O	data output bit 6; channel A
DA7	52	O	data output bit 7; channel A
DA8	53	O	data output bit 8; channel A
DA9	54	O	data output bit 9; channel A
DA10	55	O	data output bit 10; channel A
DA11	56	O	data output bit 11; channel A

Table 2. Pin description (CMOS digital outputs) ...continued

Symbol	Pin	Type ^[1]	Description
DA12	57	O	data output bit 12; channel A
DA13	58	O	data output bit 13 (MSB); channel A
OTRA	59	O	out-of-range; channel A
DECA	60	O	regulator decoupling node; channel A
VDDA	61	P	analog power supply
SENSE	62	I	reference programming pin
VREF	63	I/O	voltage reference input/output
VDDA	64	P	analog power supply

[1] P: power supply; G: ground; I: input; O: output; I/O: input/output.

6.2 LVDS DDR outputs selected

6.2.1 Pinning

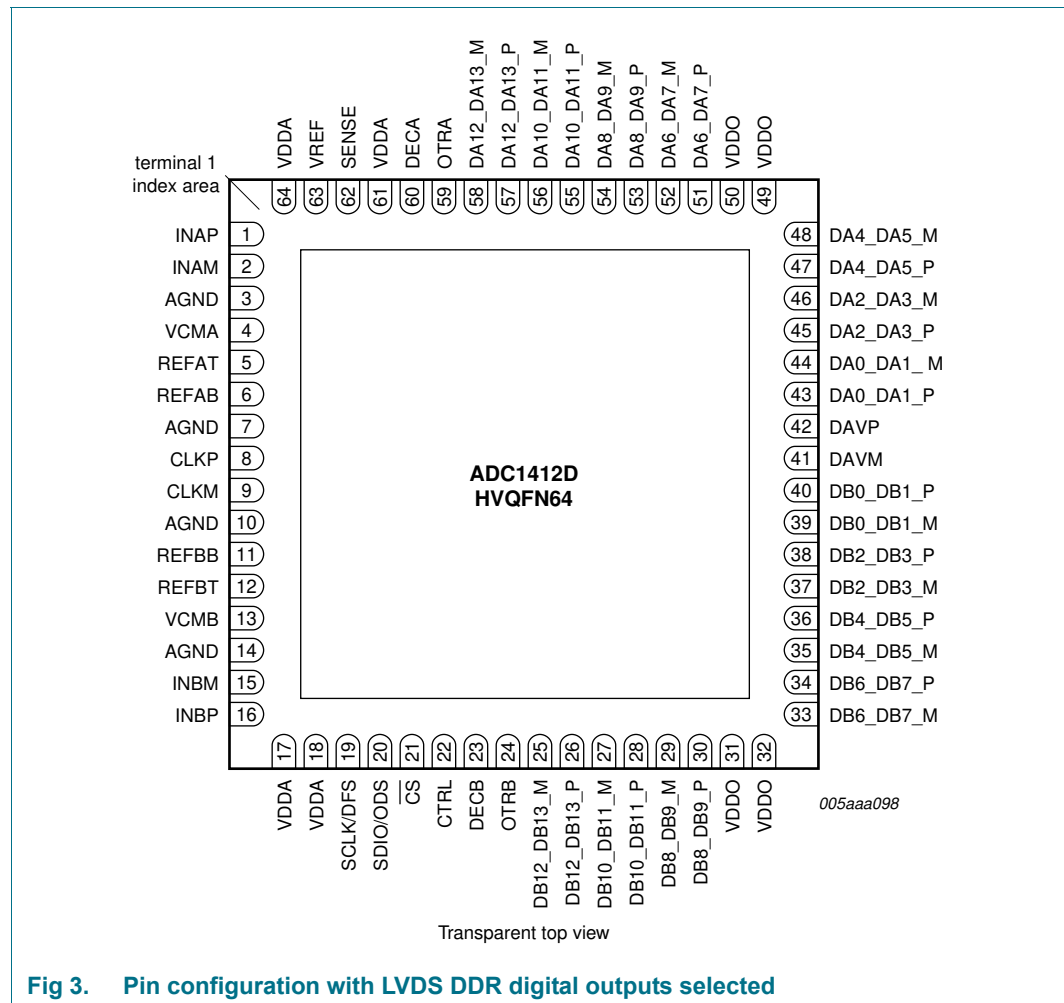

Fig 3. Pin configuration with LVDS DDR digital outputs selected

6.2.2 Pin description

Table 3. Pin description (LVDS DDR) digital outputs) [1]

Symbol	Pin	Type ^[2]	Description
DB12_DB13_M	25	O	differential output data DB12 and DB13 multiplexed, complement
DB12_DB13_P	26	O	differential output data DB12 and DB13 multiplexed, true
DB10_DB11_M	27	O	differential output data DB10 and DB11 multiplexed, complement
DB10_DB11_P	28	O	differential output data DB10 and DB11 multiplexed, true
DB8_DB9_M	29	O	differential output data DB8 and DB9 multiplexed, complement
DB8_DB9_P	30	O	differential output data DB8 and DB9 multiplexed, true
DB6_DB7_M	33	O	differential output data DB6 and DB7 multiplexed, complement
DB6_DB7_P	34	O	differential output data DB6 and DB7 multiplexed, true
DB4_DB5_M	35	O	differential output data DB4 and DB5 multiplexed, complement
DB4_DB5_P	36	O	differential output data DB4 and DB5 multiplexed, true
DB2_DB3_M	37	O	differential output data DB2 and DB3 multiplexed, complement
DB2_DB3_P	38	O	differential output data DB2 and DB3 multiplexed, true
DB0_DB1_M	39	O	differential output data DB0 and DB1 multiplexed, complement
DB0_DB1_P	40	O	differential output data DB0 and DB1 multiplexed, true
DAVM	41	O	data valid output clock, complement
DAVP	42	O	data valid output clock, true
DA0_DA1_P	43	O	differential output data DA0 and DA1 multiplexed, true
DA0_DA1_M	44	O	differential output data DA0 and DA1 multiplexed, complement
DA2_DA3_P	45	O	differential output data DA2 and DA3 multiplexed, true
DA2_DA3_M	46	O	differential output data DA2 and DA3 multiplexed, complement
DA4_DA5_P	47	O	differential output data DA4 and DA5 multiplexed, true
DA4_DA5_M	48	O	differential output data DA4 and DA5 multiplexed, complement
DA6_DA7_P	51	O	differential output data DA6 and DA7 multiplexed, true
DA6_DA7_M	52	O	differential output data DA6 and DA7 multiplexed, complement
DA8_DA9_P	53	O	differential output data DA8 and DA9 multiplexed, true
DA8_DA9_M	54	O	differential output data DA8 and DA9 multiplexed, complement
DA10_DA11_P	55	O	differential output data DA10 and DA11 multiplexed, true
DA10_DA11_M	56	O	differential output data DA10 and DA11 multiplexed, complement
DA12_DA13_P	57	O	differential output data DA12 and DA13 multiplexed, true
DA12_DA13_M	58	O	differential output data DA12 and DA13 multiplexed, complement

[1] Pins 1 to 24, pin 59 to 64 and pins 31, 32, 49 and 50 are the same for both CMOS and LVDS DDR outputs (see Table 2).

[2] P: power supply; G: ground; I: input; O: output; I/O: input/output.

7. Limiting values

Table 4. Limiting values

In accordance with the Absolute Maximum Rating System (IEC 60134).

Symbol	Parameter	Conditions	Min	Max	Unit
V_O	output voltage	pins DA13 to DA0 and DB13 to DB0 or pins DA12_DA13_P to DA0_DA1_P, DA12_DA13_M to DA0_DA1_M, DB12_DB13_P to DB0_DB1_P and DB12_DB13_M to DB0_DB1_M	-0.4	+3.9	V
V_{DDA}	analog supply voltage		-0.4	+3.9	V
V_{DDO}	output supply voltage		-0.4	+3.9	V
T_{stg}	storage temperature		-55	+125	°C
T_{amb}	ambient temperature		-40	+85	°C
T_j	junction temperature		-	125	°C

8. Thermal characteristics

Table 5. Thermal characteristics

Symbol	Parameter	Conditions	Typ	Unit
$R_{th(j-a)}$	thermal resistance from junction to ambient		[1] 15.6	K/W
$R_{th(j-c)}$	thermal resistance from junction to case		[1] 6.3	K/W

[1] Value for six layers board in still air with a minimum of 64 thermal vias.

9. Static characteristics

Table 6. Static characteristics^[1]

Symbol	Parameter	Conditions	Min	Typ	Max	Unit
Supplies						
V_{DDA}	analog supply voltage		2.85	3.0	3.4	V
V_{DDO}	output supply voltage	CMOS mode	1.65	1.8	3.6	V
		LVDS DDR mode	2.85	3.0	3.6	V
I_{DDA}	analog supply current	$f_{clk} = 125$ Msps; $f_i = 70$ MHz	-	400	-	mA
I_{DDO}	output supply current	CMOS mode; $f_{clk} = 125$ Msps; $f_i = 70$ MHz	-	18	-	mA
		LVDS DDR mode: $f_{clk} = 125$ Msps; $f_i = 70$ MHz	-	92	-	mA

Table 6. Static characteristics^[1] ...continued

Symbol	Parameter	Conditions	Min	Typ	Max	Unit
P	power dissipation	ADC1412D125; analog supply only	-	1230	-	mW
		ADC1412D105; analog supply only	-	1130	-	mW
		ADC1412D080; analog supply only	-	855	-	mW
		ADC1412D065; analog supply only	-	780	-	mW
		Power-down mode	-	24	-	mW
		Sleep mode	-	80	-	mW
Clock inputs: pins CLKP and CLKM						
LVPECL						
$V_{i(\text{clk})\text{dif}}$	differential clock input voltage	peak-to-peak	-	± 1.6	-	V
Sine						
$V_{i(\text{clk})\text{dif}}$	differential clock input voltage	peak-to-peak	± 0.8	± 3.0	-	V
LVC MOS						
V_{IL}	LOW-level input voltage		-	-	$0.3V_{\text{DDA}}$	V
V_{IH}	HIGH-level input voltage		$0.7V_{\text{DDA}}$	-	-	V
Logic input: pin CTRL						
V_{IL}	LOW-level input voltage	LOW-medium level	-	$0.3V_{\text{DDA}}$	-	V
		medium-HIGH level	-	$0.6V_{\text{DDA}}$	-	V
			-	0	-	V
V_{IH}	HIGH-level input voltage		-	V_{DDA}	-	V
I_{IL}	LOW-level input current		-10	-	+10	μA
I_{IH}	HIGH-level input current		-10	-	+10	μA
Serial peripheral interface: pins CS, SDIO/ODS, SCLK/DFS						
V_{IL}	LOW-level input voltage		0	-	$0.3V_{\text{DDA}}$	V
V_{IH}	HIGH-level input voltage		$0.7V_{\text{DDA}}$	-	V_{DDA}	V
I_{IL}	LOW-level input current		-10	-	+10	μA
I_{IH}	HIGH-level input current		-50	-	+50	μA
C_{I}	input capacitance		-	4	-	pF
Digital outputs, CMOS mode: pins DA13 to DA0, DB13 to DB0, OTRA, OTRB and DAV						
Output levels, $V_{\text{DDO}} = 3\text{ V}$						
V_{OL}	LOW-level output voltage		AGND	-	$0.2V_{\text{DDO}}$	V
V_{OH}	HIGH-level output voltage		$0.8V_{\text{DDO}}$	-	V_{DDO}	V
C_{O}	output capacitance	high impedance; see Table 10	-	3	-	pF
Output levels, $V_{\text{DDO}} = 1.8\text{ V}$						
V_{OL}	LOW-level output voltage		AGND	-	$0.2V_{\text{DDO}}$	V
V_{OH}	HIGH-level output voltage		$0.8V_{\text{DDO}}$	-	V_{DDO}	V

Table 6. Static characteristics^[1] ...continued

Symbol	Parameter	Conditions	Min	Typ	Max	Unit
Digital outputs, LVDS DDR mode: pins DA12_DA13_P to DA0_DA1_P, DA12_DA13_M to DA0_DA1_M, DB12_DB13_P to DB0_DB1_P, DB12_DB13_M to DB0_DB1_M, DAVP and DAVM						
Output levels, $V_{DDO} = 3\text{ V}$ only, $R_L = 100\ \Omega$						
$V_{O(\text{offset})}$	output offset voltage	output buffer current set to 3.5 mA	-	1.2	-	V
$V_{O(\text{dif})}$	differential output voltage	output buffer current set to 3.5 mA	-	350	-	mV
C_O	output capacitance		-	3	-	pF
Analog inputs: pins INAP, INAM, INBP and INBM						
I_I	input current		-5	-	+5	μA
R_I	input resistance		-	19.8	-	k Ω
C_I	input capacitance		-	2.8	-	pF
$V_{I(\text{cm})}$	common-mode input voltage	$V_{INAP} = V_{INAM}$; $V_{INBP} = V_{INBM}$	0.9	1.5	2	V
B_I	input bandwidth		-	600	-	MHz
$V_{I(\text{dif})}$	differential input voltage	peak-to-peak	1	-	2	V
Common-mode output voltage: pins VCMA and VCMB						
$V_{O(\text{cm})}$	common-mode output voltage		-	$0.5V_{DDA}$	-	V
$I_{O(\text{cm})}$	common-mode output current		-	4	-	μA
I/O reference voltage: pin VREF						
V_{VREF}	voltage on pin VREF	output	-	0.5 to 1	-	V
		input	0.5	-	1	V
Accuracy						
INL	integral non-linearity		-5	± 1	+5	LSB
DNL	differential non-linearity	guaranteed no missing codes	-0.95	± 0.5	+0.95	LSB
E_{offset}	offset error		-	± 2	-	mV
E_G	gain error	full-scale	-	± 0.5	-	%
$M_{G(\text{CTC})}$	channel-to-channel gain matching		-	1.1	-	%
Supply						
PSRR	power supply rejection ratio	200 mV (p-p) on pin VDDA; $f_i = \text{DC}$	-	-37	-	dB

[1] Typical values measured at $V_{DDA} = 3\text{ V}$, $V_{DDO} = 1.8\text{ V}$, $T_{\text{amb}} = 25\text{ }^\circ\text{C}$; minimum and maximum values are across the full temperature range $T_{\text{amb}} = -40\text{ }^\circ\text{C}$ to $+85\text{ }^\circ\text{C}$ at $V_{DDA} = 3\text{ V}$, $V_{DDO} = 1.8\text{ V}$; $V_{INAP} - V_{INAM} = -1\text{ dBFS}$; $V_{INBP} - V_{INBM} = -1\text{ dBFS}$; internal reference mode; applied to CMOS and LVDS interface; unless otherwise specified.

10. Dynamic characteristics

10.1 Dynamic characteristics

Table 7. Dynamic characteristics^[1]

Symbol	Parameter	Conditions	ADC1412D065			ADC1412D080			ADC1412D105			ADC1412D125			Unit
			Min	Typ	Max	Min	Typ	Max	Min	Typ	Max	Min	Typ	Max	
Analog signal processing															
α_{2H}	second harmonic level	$f_i = 3$ MHz	-	87	-	-	87	-	-	86	-	-	88	-	dBc
		$f_i = 30$ MHz	-	86	-	-	86	-	-	86	-	-	87	-	dBc
		$f_i = 70$ MHz	-	85	-	-	85	-	-	84	-	-	85	-	dBc
		$f_i = 170$ MHz	-	82	-	-	82	-	-	81	-	-	83	-	dBc
α_{3H}	third harmonic level	$f_i = 3$ MHz	-	86	-	-	86	-	-	85	-	-	87	-	dBc
		$f_i = 30$ MHz	-	85	-	-	85	-	-	85	-	-	86	-	dBc
		$f_i = 70$ MHz	-	84	-	-	84	-	-	83	-	-	84	-	dBc
		$f_i = 170$ MHz	-	81	-	-	81	-	-	80	-	-	82	-	dBc
THD	total harmonic distortion	$f_i = 3$ MHz	-	83	-	-	83	-	-	82	-	-	84	-	dBc
		$f_i = 30$ MHz	-	82	-	-	82	-	-	82	-	-	83	-	dBc
		$f_i = 70$ MHz	-	81	-	-	81	-	-	80	-	-	81	-	dBc
		$f_i = 170$ MHz	-	78	-	-	78	-	-	77	-	-	79	-	dBc
ENOB	effective number of bits	$f_i = 3$ MHz	-	11.7	-	-	11.7	-	-	11.6	-	-	11.6	-	bit
		$f_i = 30$ MHz	-	11.6	-	-	11.5	-	-	11.5	-	-	11.5	-	bit
		$f_i = 70$ MHz	-	11.5	-	-	11.5	-	-	11.4	-	-	11.4	-	bit
		$f_i = 170$ MHz	-	11.4	-	-	11.4	-	-	11.3	-	-	11.3	-	bit
SNR	signal-to-noise ratio	$f_i = 3$ MHz	-	72.1	-	-	72.0	-	-	71.8	-	-	71.4	-	dBFS
		$f_i = 30$ MHz	-	71.3	-	-	71.2	-	-	71.2	-	-	71.1	-	dBFS
		$f_i = 70$ MHz	-	70.7	-	-	70.7	-	-	70.6	-	-	70.5	-	dBFS
		$f_i = 170$ MHz	-	70.2	-	-	70.1	-	-	70.0	-	-	69.9	-	dBFS
SFDR	spurious-free dynamic range	$f_i = 3$ MHz	-	86	-	-	86	-	-	85	-	-	87	-	dBc
		$f_i = 30$ MHz	-	85	-	-	85	-	-	85	-	-	86	-	dBc
		$f_i = 70$ MHz	-	84	-	-	84	-	-	83	-	-	84	-	dBc
		$f_i = 170$ MHz	-	81	-	-	81	-	-	80	-	-	82	-	dBc

Table 7. Dynamic characteristics^[1] ...continued

Symbol	Parameter	Conditions	ADC1412D065			ADC1412D080			ADC1412D105			ADC1412D125			Unit
			Min	Typ	Max	Min	Typ	Max	Min	Typ	Max	Min	Typ	Max	
IMD	Intermodulation distortion	$f_i = 3$ MHz	-	89	-	-	89	-	-	88	-	-	89	-	dBc
		$f_i = 30$ MHz	-	88	-	-	88	-	-	88	-	-	88	-	dBc
		$f_i = 70$ MHz	-	87	-	-	87	-	-	86	-	-	86	-	dBc
		$f_i = 170$ MHz	-	84	-	-	85	-	-	83	-	-	84	-	dBc
$\alpha_{ct(ch)}$	channel crosstalk	$f_i = 70$ MHz	-	100	-	-	100	-	-	100	-	-	100	-	dBc

[1] Typical values measured at $V_{DDA} = 3$ V, $V_{DDO} = 1.8$ V, $T_{amb} = 25$ °C; minimum and maximum values are across the full temperature range $T_{amb} = -40$ °C to $+85$ °C at $V_{DDA} = 3$ V, $V_{DDO} = 1.8$ V; $V_{INAP} - V_{INAM} = -1$ dBFS; $V_{INBP} - V_{INBM} = -1$ dBFS; internal reference mode; applied to CMOS and LVDS interface; unless otherwise specified.

10.2 Clock and digital output timing

Table 8. Clock and digital output timing characteristics^[1]

Symbol	Parameter	Conditions	ADC1412D065			ADC1412D080			ADC1412D105			ADC1412D125			Unit	
			Min	Typ	Max	Min	Typ	Max	Min	Typ	Max	Min	Typ	Max		
Clock timing input: pins CLKP and CLKM																
f_{clk}	clock frequency		20	-	65	60	-	80	75	-	105	100	-	125	MHz	
$t_{lat(data)}$	data latency time		-	14	-	-	14	-	-	14	-	-	14	-	clock cycles	
δ_{clk}	clock duty cycle	DCS_EN = 1	30	50	70	30	50	70	30	50	70	30	50	70	%	
		DCS_EN = 0	45	50	55	45	50	55	45	50	55	45	50	55	%	
$t_{d(s)}$	sampling delay time		-	0.8	-	-	0.8	-	-	0.8	-	-	0.8	-	ns	
t_{wake}	wake-up time		-	76	-	-	76	-	-	76	-	-	76	-	μ s	
CMOS mode timing: pins DA13 to DA0, DB13 to DB0 and DAV																
t_{PD}	propagation delay	DATA	-	3.9	-	-	3.9	-	-	3.9	-	-	3.9	-	ns	
		DAV	-	4.2	-	-	4.2	-	-	4.2	-	-	4.2	-	ns	
t_{su}	set-up time		-	8.6	-	-	7.4	-	-	6.1	-	-	5.7	-	ns	
t_h	hold time		-	4.8	-	-	3.4	-	-	1.8	-	-	1.4	-	ns	
t_r	rise time	DATA	[2]	0.5	-	2.4	0.5	-	2.4	0.5	-	2.4	0.5	-	2.4	ns
		DAV		0.5	-	2.4	0.5	-	2.4	0.5	-	2.4	0.5	-	2.4	ns
t_f	fall time	DATA	[2]	0.5	-	2.4	0.5	-	2.4	0.5	-	2.4	0.5	-	2.4	ns

Table 8. Clock and digital output timing characteristics^[1] ...continued

Symbol	Parameter	Conditions	ADC1412D065			ADC1412D080			ADC1412D105			ADC1412D125			Unit
			Min	Typ	Max	Min	Typ	Max	Min	Typ	Max	Min	Typ	Max	
LVDS DDR mode timing: pins DA12_DA13_P to DA0_DA1_P, DA12_DA13_M to DA0_DA1_M, DB12_DB13_P to DB0_DB1_P, DB12_DB13_M to DB0_DB1_M, DAVP and DAVM															
t _{PD}	propagation delay	DATA	-	3.9	-	-	3.9	-	-	3.9	-	-	3.9	-	ns
		DAV	-	4.2	-	-	4.2	-	-	4.2	-	-	4.2	-	ns
t _{su}	set-up time		-	5.1	-	-	3.5	-	-	2.1	-	-	1.4	-	ns
t _h	hold time		-	2.0	-	-	2.0	-	-	2.0	-	-	2.0	-	ns
t _r	rise time	DATA	^[3] 50	100	200	50	100	200	50	100	200	50	100	200	ps
		DAV	50	100	200	50	100	200	50	100	200	50	100	200	ps
t _f	fall time	DATA	^[3] 50	100	200	50	100	200	50	100	200	50	100	200	ps
		DAV	50	100	200	50	100	200	50	100	200	50	100	200	ps

[1] Typical values measured at V_{DDA} = 3 V, V_{DDO} = 1.8 V, T_{amb} = 25 °C; minimum and maximum values are across the full temperature range T_{amb} = -40 °C to +85 °C at V_{DDA} = 3 V, V_{DDO} = 1.8 V; V_{INAP} - V_{INAM} = -1 dBFS; V_{INBP} - V_{INBM} = -1 dBFS; unless otherwise specified.

[2] Measured between 20 % to 80 % of V_{DDO}.

[3] Rise time measured from -50 mV to +50 mV; fall time measured from +50 mV to -50 mV.

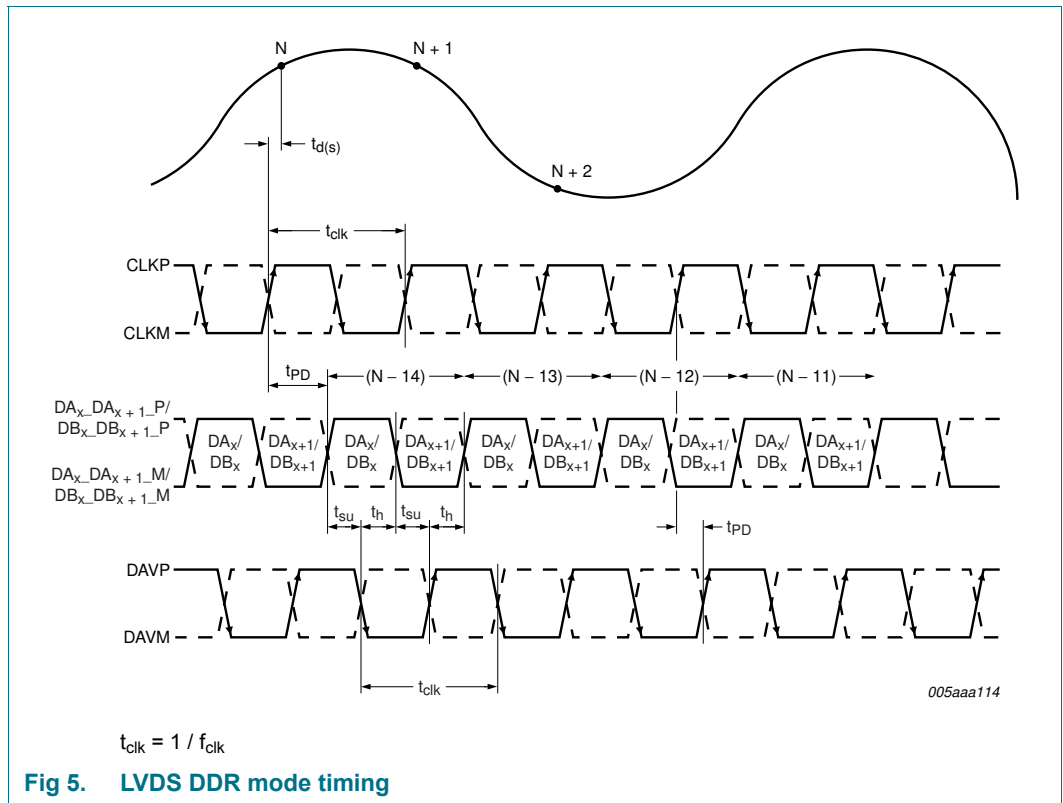
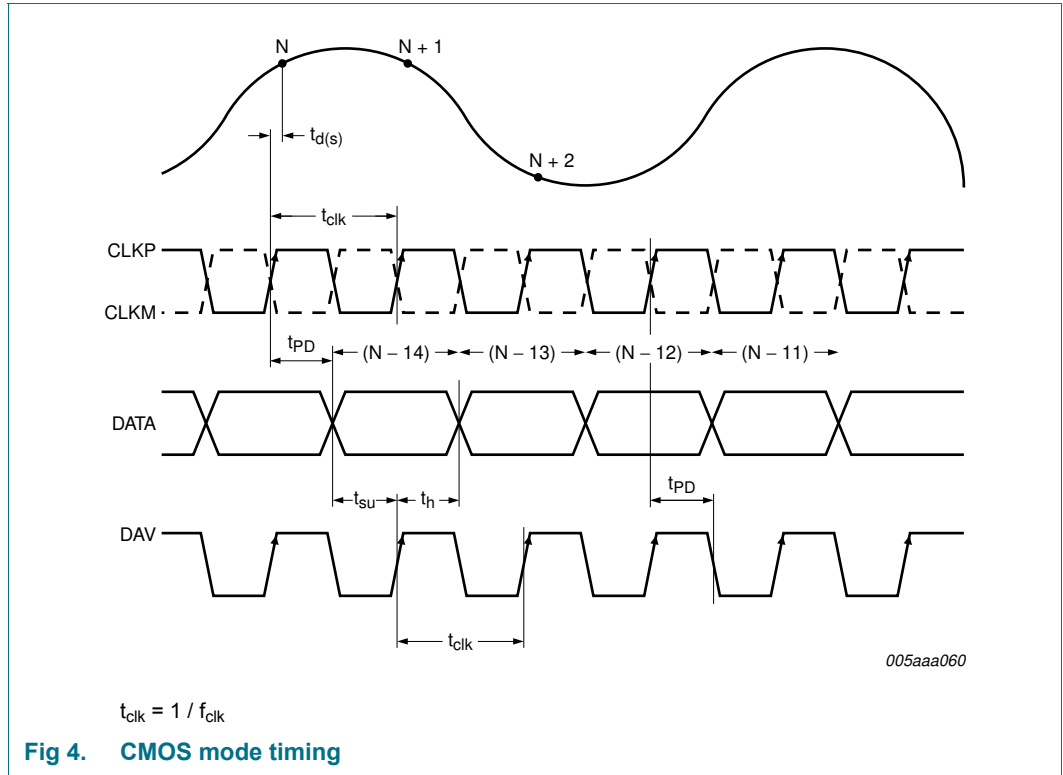

10.3 SPI timings

Table 9. Characteristics

Symbol	Parameter	Conditions	Min	Typ	Max	Unit
SPI timings						
$t_{w(SCLK)}$	SCLK pulse width		-	40	-	ns
$t_{w(SCLKH)}$	SCLK HIGH pulse width		-	16	-	ns
$t_{w(SCLKL)}$	SCLK LOW pulse width		-	16	-	ns
t_{su}	set-up time	data to SCLK HIGH	-	5	-	ns
		\overline{CS} to SCLK HIGH	-	5	-	ns
t_h	hold time	data to SCLK HIGH	-	2	-	ns
		\overline{CS} to SCLK HIGH	-	2	-	ns
$f_{clk(max)}$	maximum clock frequency		-	25	-	MHz

[1] Typical values measured at $V_{DDA} = 3\text{ V}$, $V_{DDO} = 1.8\text{ V}$, $T_{amb} = 25\text{ }^\circ\text{C}$; minimum and maximum values are across the full temperature range $T_{amb} = -40\text{ }^\circ\text{C}$ to $+85\text{ }^\circ\text{C}$ at $V_{DDA} = 3\text{ V}$, $V_{DDO} = 1.8\text{ V}$.

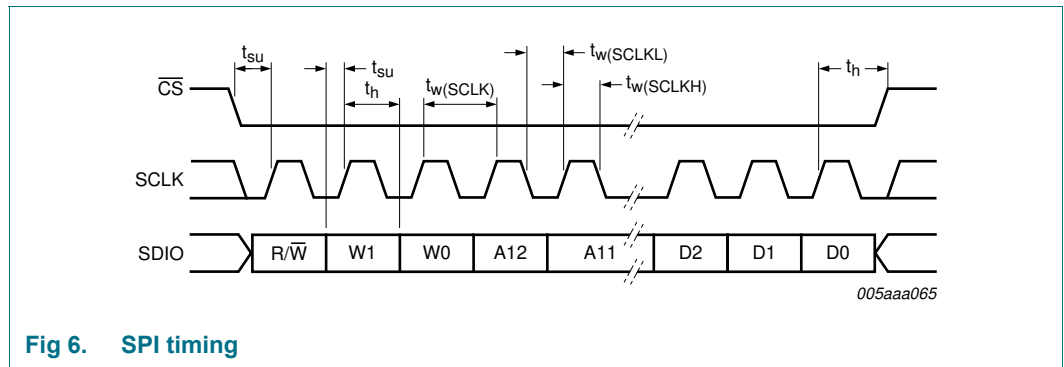

Fig 6. SPI timing

10.4 Typical characteristics

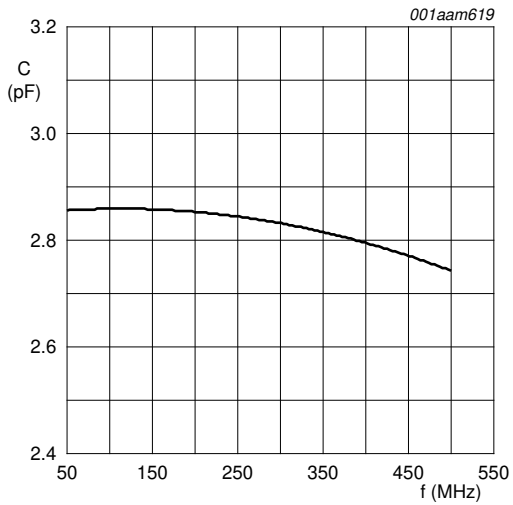

Fig 7. Capacitance as a function of frequency

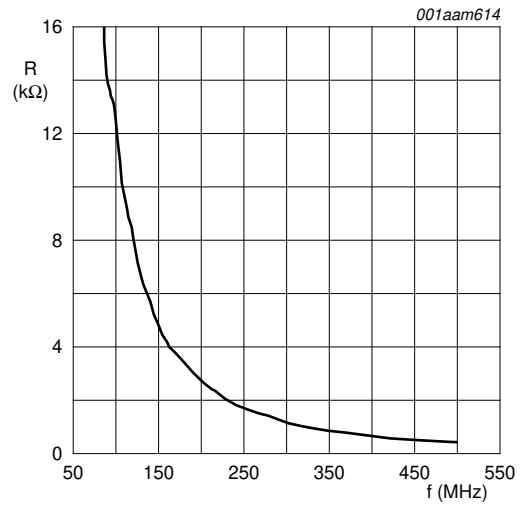
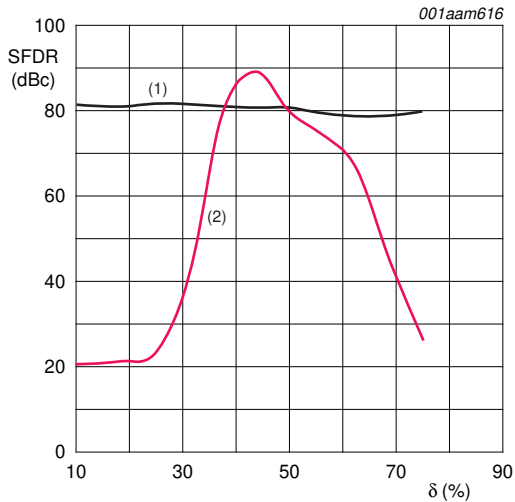
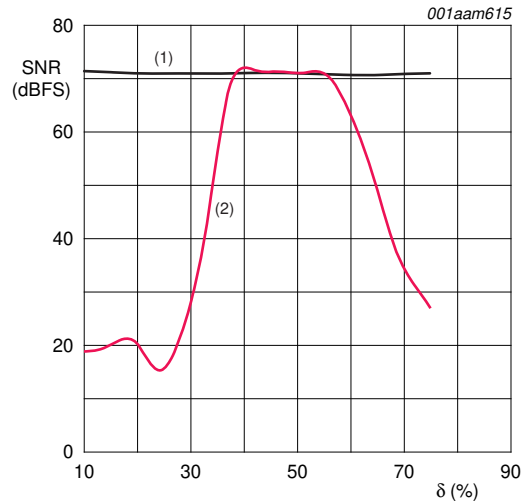

Fig 8. Resistance as a function of frequency



T = 25 °C; V_{DD} = 3 V; f_i = 170 MHz; f_s = 125 Msps
 (1) DCS on
 (2) DCS off

Fig 9. SFDR as a function of duty cycle (δ)



T = 25 °C; V_{DD} = 3 V; f_i = 170 MHz; f_s = 125 Msps
 (1) DCS on
 (2) DCS off

Fig 10. SNR as a function of duty cycle (δ)

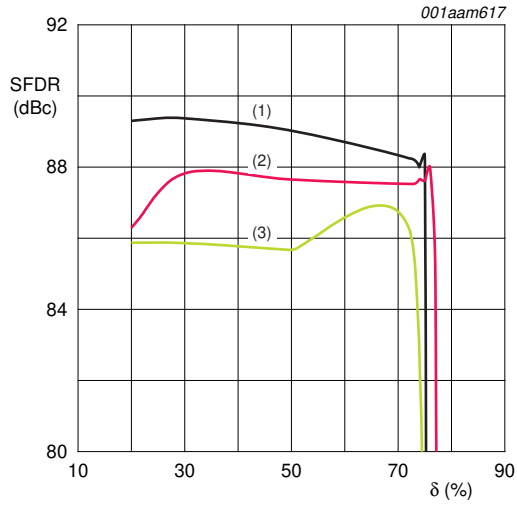

- (1) $T_{amb} = -40\text{ }^{\circ}\text{C}$ /typical supply voltages
- (2) $T_{amb} = +25\text{ }^{\circ}\text{C}$ /typical supply voltages
- (3) $T_{amb} = +90\text{ }^{\circ}\text{C}$ /typical supply voltages

Fig 11. SFDR as a function of duty cycle (δ)

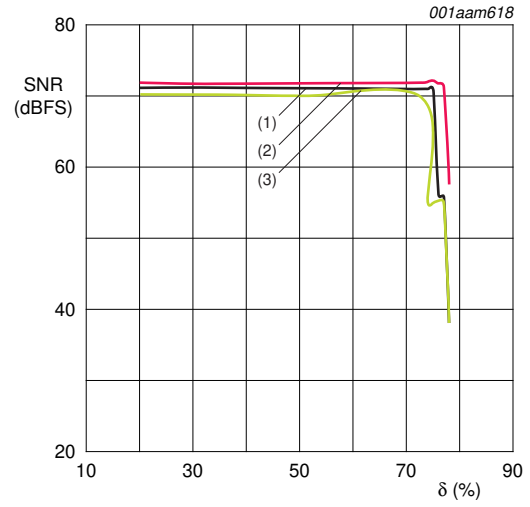

- (1) $T_{amb} = -40\text{ }^{\circ}\text{C}$ /typical supply voltages
- (2) $T_{amb} = +25\text{ }^{\circ}\text{C}$ /typical supply voltages
- (3) $T_{amb} = +90\text{ }^{\circ}\text{C}$ /typical supply voltages

Fig 12. SNR as a function of duty cycle (δ)

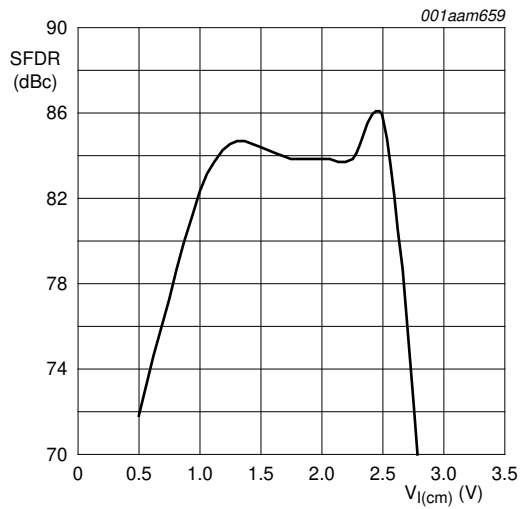

Fig 13. SFDR as a function of common-mode input voltage ($V_{I(cm)}$)

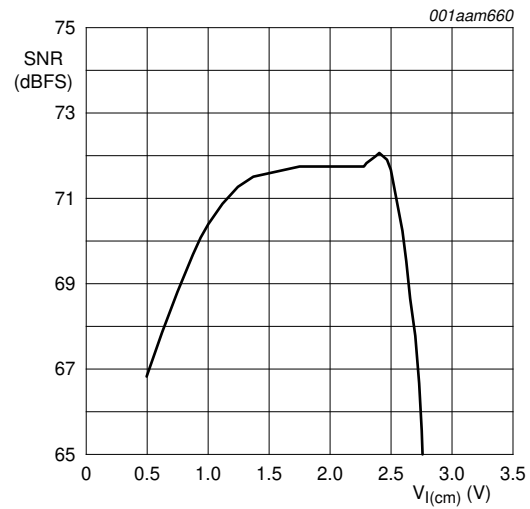

Fig 14. SNR as a function of common-mode input voltage ($V_{I(cm)}$)

11. Application information

11.1 Device control

The ADC1412D can be controlled via the Serial Peripheral Interface (SPI control mode) or directly via the I/O pins (Pin control mode).

11.1.1 SPI and Pin control modes

The device enters Pin control mode at power-up and remains in this mode as long as pin \overline{CS} is held HIGH. In Pin control mode, the SPI pins SDIO, \overline{CS} and SCLK are used as static control pins.

SPI control mode is enabled by forcing pin \overline{CS} LOW. Once SPI control mode has been enabled, the device remains in this mode. The transition from Pin control mode to SPI control mode is illustrated in Figure 15.

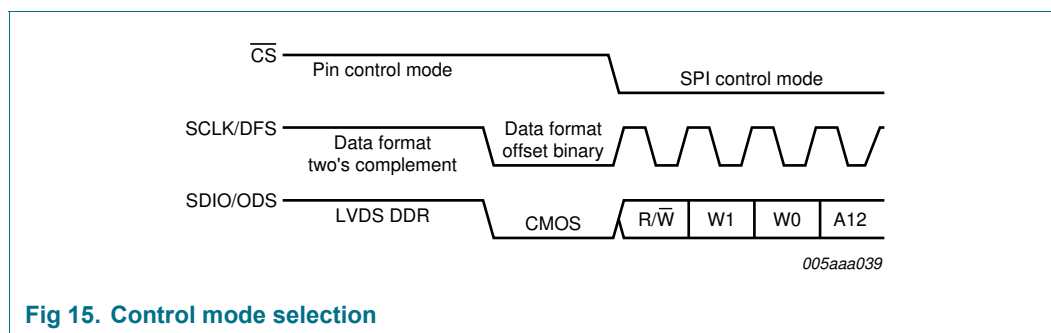

Fig 15. Control mode selection

When the device enters SPI control mode, the output data standard and data format are determined by the level on pin SDIO as soon as a transition is triggered by a falling edge on \overline{CS} .

11.1.2 Operating mode selection

The active ADC1412D operating mode (Power-up, Power-down or Sleep) can be selected via the SPI interface (see Table 21) or by using pin CTRL in Pin control mode, as described in Table 10.

Table 10. Operating mode selection via pin CTRL

Pin CTRL	Operating mode	Output high-Z
0	Power-down	yes
0.3V _{DDA}	Sleep	yes
0.6V _{DDA}	Power-up	yes
V _{DDA}	Power-up	no

11.1.3 Selecting the output data standard

The output data standard (CMOS or LVDS DDR) can be selected via the SPI interface (see Table 24) or by using pin ODS in Pin control mode. LVDS DDR is selected when ODS is HIGH, otherwise CMOS is selected.

11.1.4 Selecting the output data format

The output data format can be selected via the SPI interface (offset binary, two's complement or gray code; see Table 24) or by using pin DFS in Pin control mode (offset binary or two's complement). Offset binary is selected when DFS is LOW. When DFS is HIGH, two's complement is selected.

11.2 Analog inputs

11.2.1 Input stage

The analog input of the ADC1412D supports a differential or a single-ended input drive. Optimal performance is achieved using differential inputs with the common-mode input voltage ($V_{I(cm)}$) on pins INAP, INAM, INBP and INBM set to $0.5V_{DDA}$.

The full-scale analog input voltage range is configurable between 1 V (p-p) and 2 V (p-p) via a programmable internal reference (see Section 11.3 and Table 23).

The equivalent circuit of the sample-and-hold input stage, including ElectroStatic Discharge (ESD) protection and circuit and package parasitics, is shown in Figure 16.

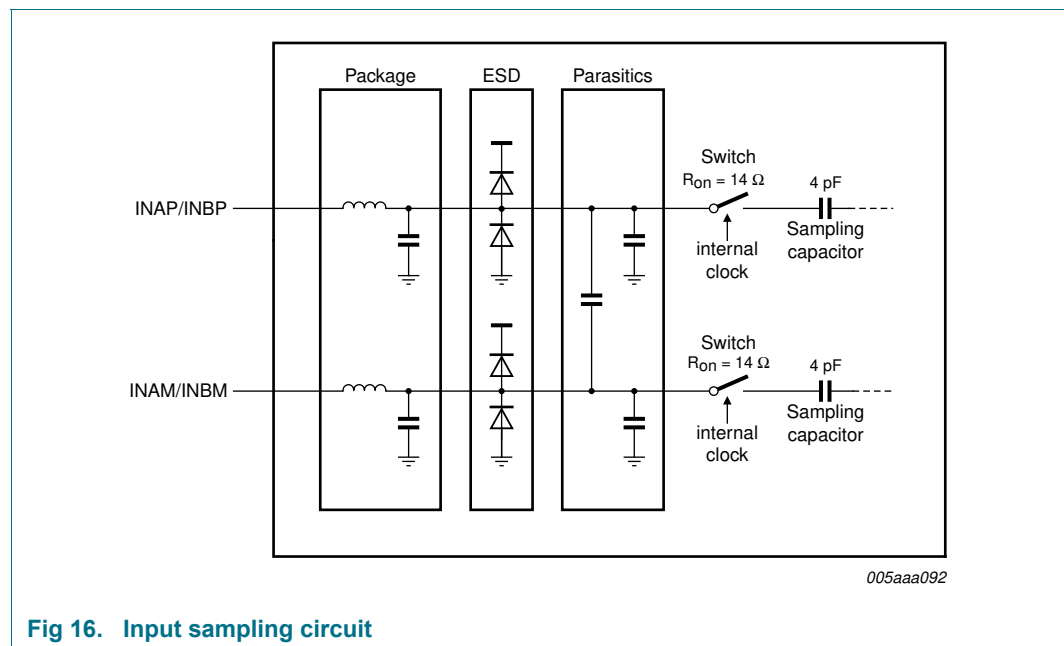

Fig 16. Input sampling circuit

The sample phase occurs when the internal clock (derived from the clock signal on pin CLKP/CLKM) is HIGH. The voltage is then held on the sampling capacitors. When the clock signal goes LOW, the stage enters the hold phase and the voltage information is transmitted to the ADC core.

11.2.2 Anti-kickback circuitry

Anti-kickback circuitry (RC filter in Figure 17) is needed to counteract the effects of charge injection generated by the sampling capacitance.

The RC filter is also used to filter noise from the signal before it reaches the sampling stage. The value of the capacitor should be chosen to maximize noise attenuation without degrading the settling time excessively.

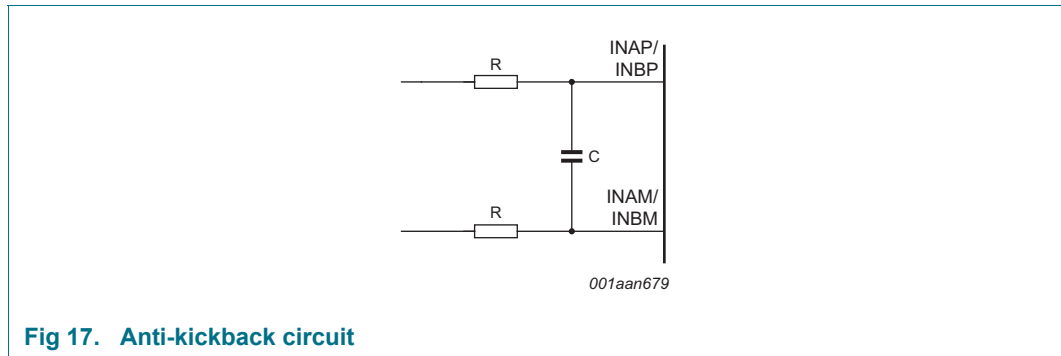

Fig 17. Anti-kickback circuit

The component values are determined by the input frequency and should be selected so as not to affect the input bandwidth.

Table 11. RC coupling versus input frequency, typical values

Input frequency (MHz)	R (Ω)	C (pF)
3	25	12
70	12	8
170	12	8

11.2.3 Transformer

The configuration of the transformer circuit is determined by the input frequency. The configuration shown in Figure 18 would be suitable for a baseband application.

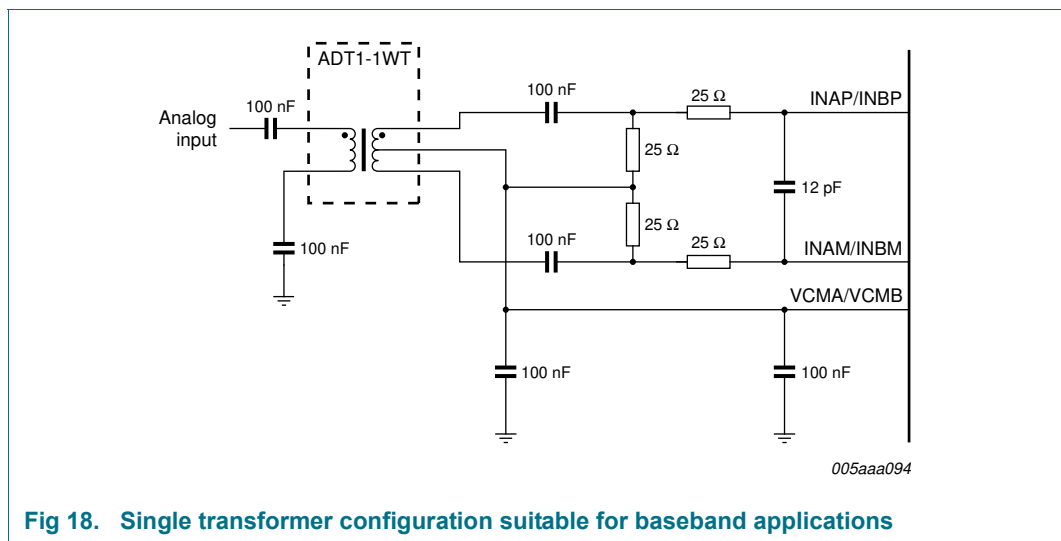
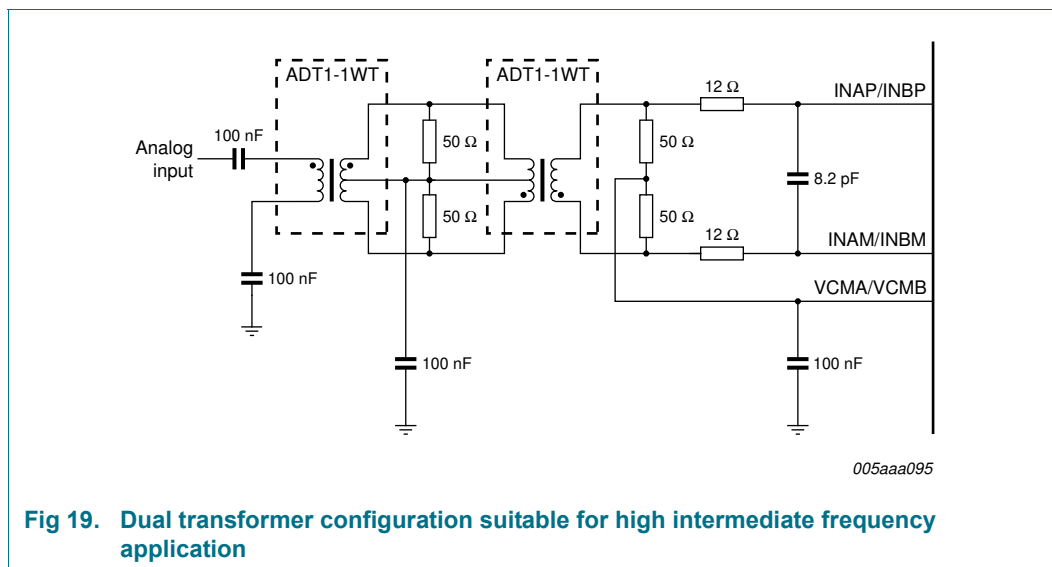

Fig 18. Single transformer configuration suitable for baseband applications

The configuration shown in Figure 19 is recommended for high frequency applications. In both cases, the choice of transformer is a compromise between cost and performance.



11.3 System reference and power management

11.3.1 Internal/external references

The ADC1412D has a stable and accurate built-in internal reference voltage to adjust the ADC full-scale. This reference voltage can be set internally via SPI or with pins VREF and SENSE (programmable in 1 dB steps between 0 dB and -6 dB via control bits INTREF[2:0] when bit INTREF_EN = logic 1; see Table 23). See Figure 21 to Figure 24. The equivalent reference circuit is shown in Figure 20. External reference is also possible by providing a voltage on pin VREF as described in Figure 23.

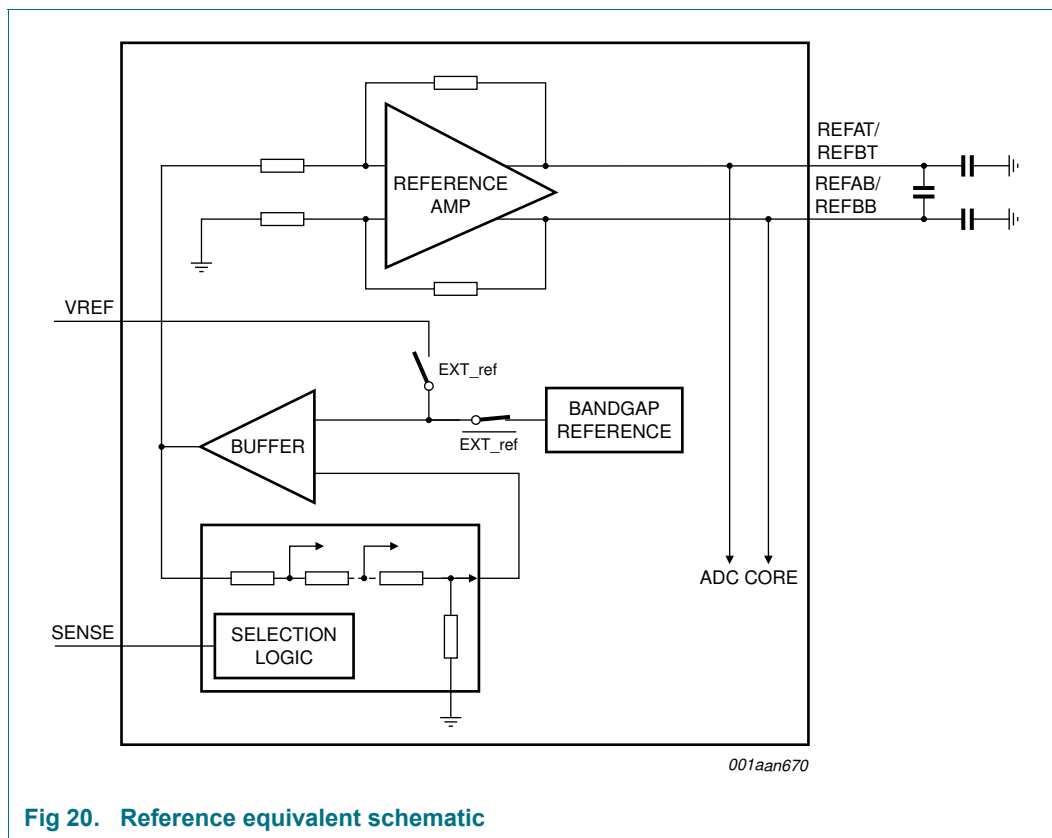

Fig 20. Reference equivalent schematic

If bit INTREF_EN is set to logic 0, the reference voltage is determined either internally or externally as detailed in Table 12.

Table 12. Reference selection

Selection	SPI bit INTREF_EN	SENSE pin	VREF pin	Full-scale (V (p-p))
Internal (Figure 21)	0	AGND	330 pF capacitor to AGND	2 V
Internal (Figure 22)	0	pin VREF connected to pin SENSE and via a 330 pF capacitor to AGND		1 V
External (Figure 23)	0	V _{DDA}	external voltage between 0.5 V and 1 V ^[1]	1 V to 2 V
Internal via SPI (Figure 24)	1	pin VREF connected to pin SENSE and via 330 pF capacitor to AGND		1 V to 2 V

[1] The voltage on pin VREF is doubled internally to generate the internal reference voltage.

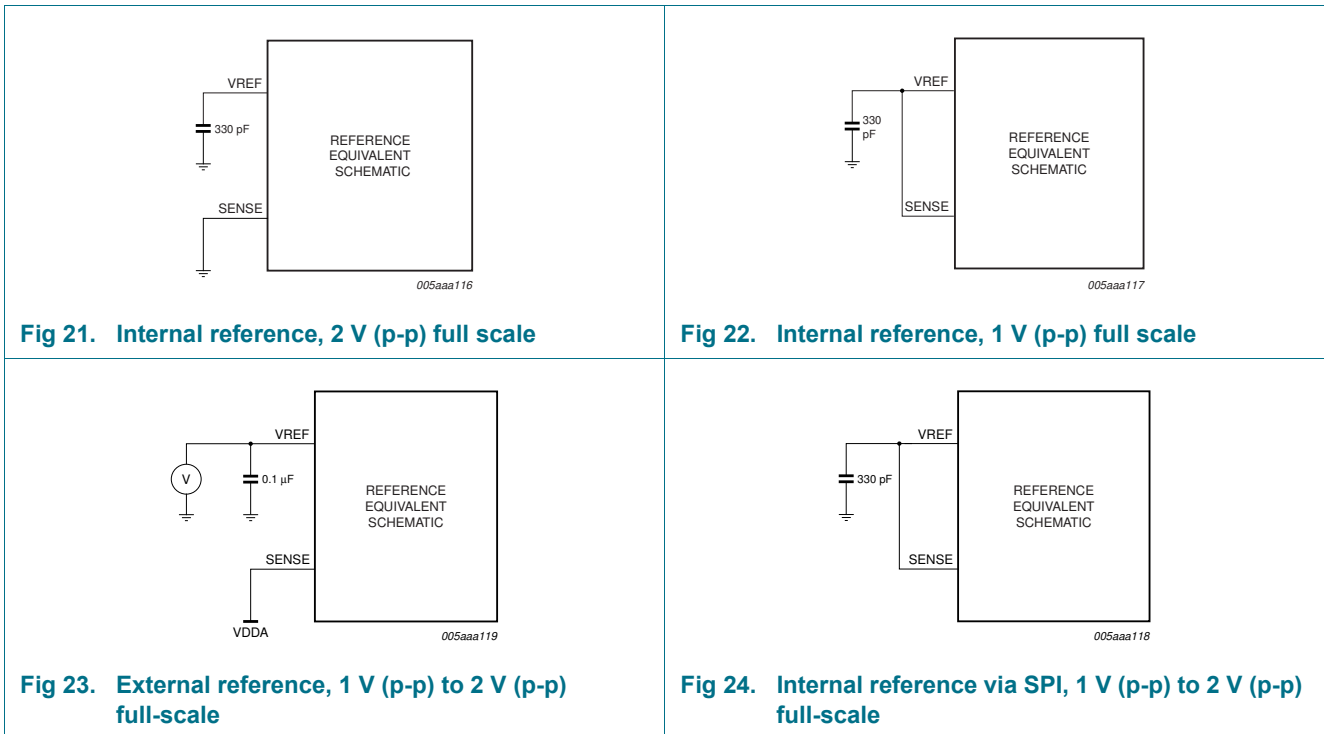

Figure 21 to Figure 24 illustrate how to connect the SENSE and VREF pins to select the required reference voltage source.

11.3.2 Programmable full-scale

The full-scale is programmable between 1 V (p-p) to 2 V (p-p) (see Table 13).

Table 13. Programmable full-scale

INTREF	Level (dB)	Full-scale (V (p-p))
000	0	2
001	-1	1.78
010	-2	1.59
011	-3	1.42
100	-4	1.26
101	-5	1.12
110	-6	1
111	reserved	x

11.3.3 Common-mode output voltage ($V_{O(cm)}$)

A 0.1 μF filter capacitor should be connected between pin VCMA/VCMB and ground to ensure a low-noise common-mode output voltage. When AC-coupled, pin VCMA/VCMB can then be used to set the common-mode reference for the analog inputs, for instance via a transformer middle point.

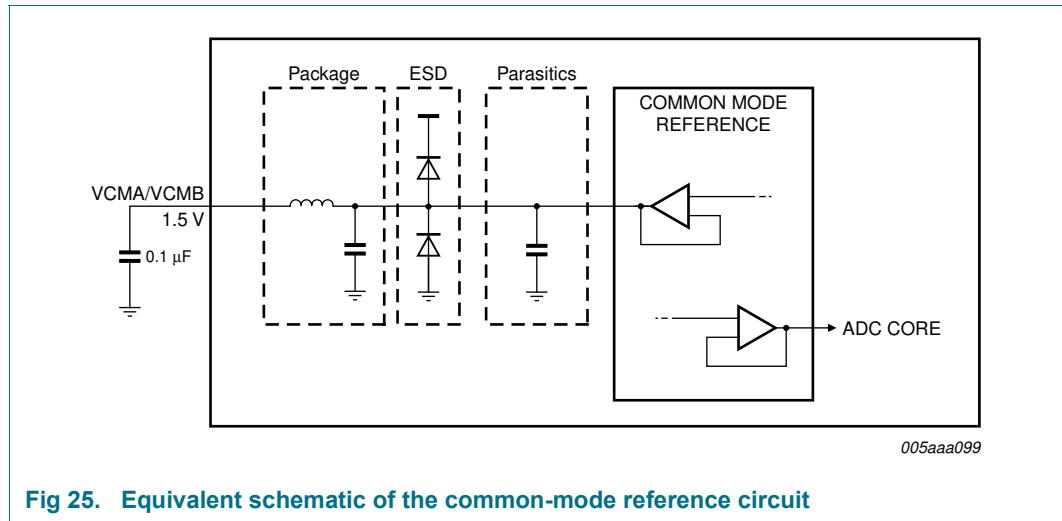

11.3.4 Biasing

The common-mode input voltage ($V_{I(cm)}$) on pins INAP/INBP and INAM/INBM should be set externally to $0.5V_{DDA}$ for optimal performance and should always be between 0.9 V and 2 V (see Table 6).

11.4 Clock input

11.4.1 Drive modes

The ADC1412D can be driven differentially (LVPECL). It can also be driven by a single-ended LVCMOS signal connected to pin CLKP (pin CLKM should be connected to ground via a capacitor) or pin CLKM (pin CLKP should be connected to ground via a capacitor).

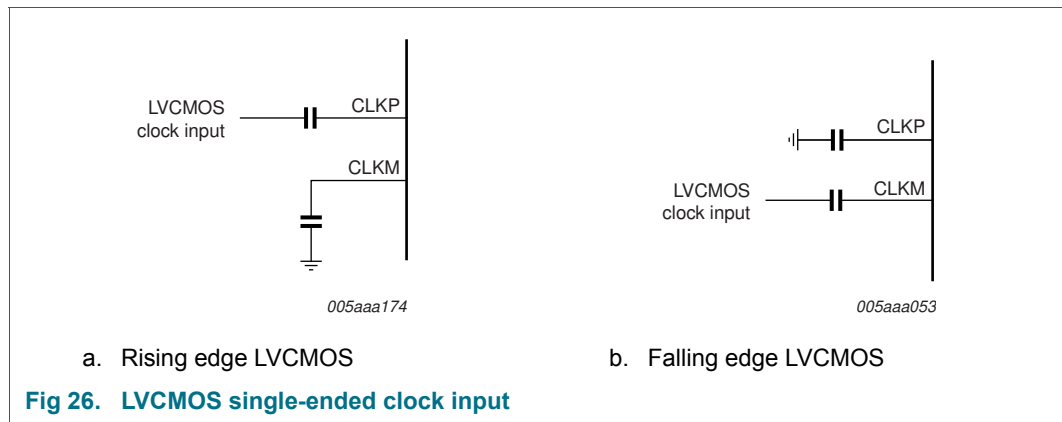

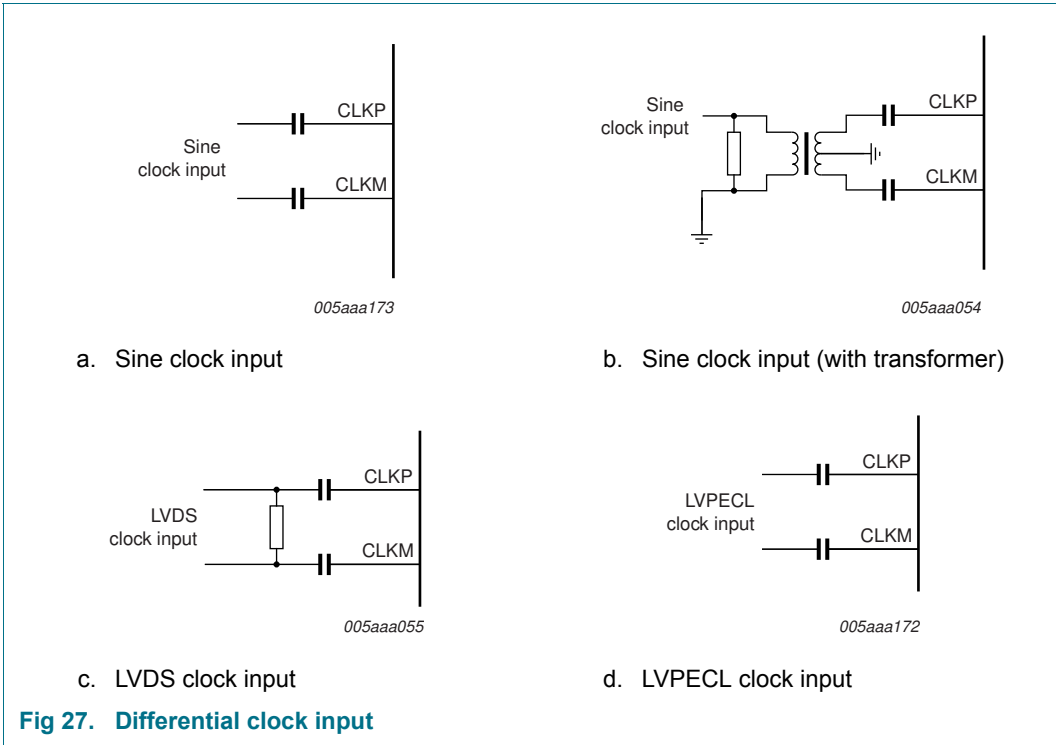

11.4.2 Equivalent input circuit

The equivalent circuit of the input clock buffer is shown in Figure 28. The common-mode voltage of the differential input stage is set via internal 5 k Ω resistors.

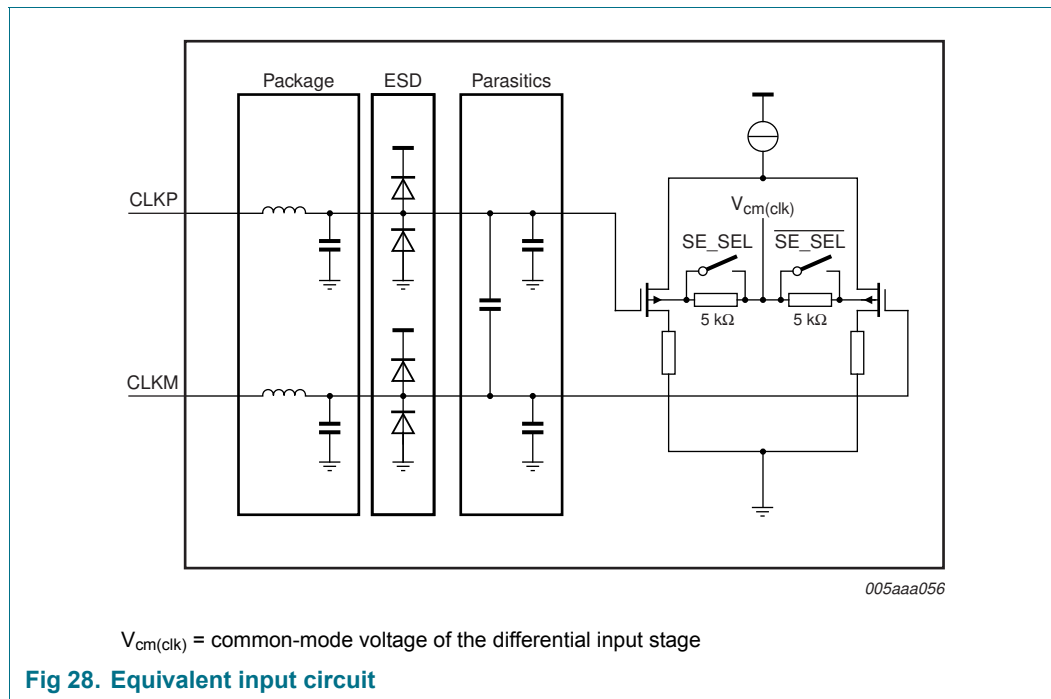

Single-ended or differential clock inputs can be selected via the SPI interface (see Table 22). If single-ended is enabled, the input pin (CLKM or CLKP) is selected via control bit SE_SEL.

If single-ended is implemented without setting bit SE_SEL to the appropriate value, the unused pin should be connected to ground via a capacitor.

11.4.3 Duty cycle stabilizer

The duty cycle stabilizer can improve the overall performance of the ADC by compensating the duty cycle of the input clock signal. When the duty cycle stabilizer is active (bit DCS_EN = logic 1; see Table 22), the circuit can handle signals with duty cycles of between 30 % and 70 % (typical). When the duty cycle stabilizer is disabled (DCS_EN = logic 0), the input clock signal should have a duty cycle of between 45 % and 55 %.

11.4.4 Clock input divider

The ADC1412D contains an input clock divider that divides the incoming clock by a factor of 2 (when bit CLKDIV = logic 1; see Table 22). This feature allows the user to deliver a higher clock frequency with better jitter performance, leading to a better SNR result once acquisition has been performed.