



Chipsmall Limited consists of a professional team with an average of over 10 year of expertise in the distribution of electronic components. Based in Hongkong, we have already established firm and mutual-benefit business relationships with customers from,Europe,America and south Asia,supplying obsolete and hard-to-find components to meet their specific needs.

With the principle of “Quality Parts,Customers Priority,Honest Operation,and Considerate Service”,our business mainly focus on the distribution of electronic components. Line cards we deal with include Microchip,ALPS,ROHM,Xilinx,Pulse,ON,Everlight and Freescale. Main products comprise IC,Modules,Potentiometer,IC Socket,Relay,Connector.Our parts cover such applications as commercial,industrial, and automotives areas.

We are looking forward to setting up business relationship with you and hope to provide you with the best service and solution. Let us make a better world for our industry!



Contact us

Tel: +86-755-8981 8866 Fax: +86-755-8427 6832

Email & Skype: info@chipsmall.com Web: www.chipsmall.com

Address: A1208, Overseas Decoration Building, #122 Zhenhua RD., Futian, Shenzhen, China



Setting Up the Evaluation Board for the ADCLK905/ADCLK907/ADCLK925

PACKAGE LIST

Evaluation board with component installed

Applicable documents (schematic, layout, and so on)

GENERAL DESCRIPTION

This user guide describes how to set up and use the evaluation board for the [ADCLK905/ADCLK907/ADCLK925](#). The same printed circuit board (PCB) is used to evaluate all three devices. The ADCLK905/ADCLK907/ADCLK925 data sheet should be used in conjunction with this user guide.

The data sheet contains full technical details about the specifications and operation of these devices.

The ADCLK905/ADCLK907/ADCLK925 clock buffers are very fast, making it important to use adequate high bandwidth instruments to evaluate them. To that end, the evaluation board is fabricated using a high quality dielectric material between layers to maintain high signal integrity. Transmission line paths are kept as close to 50 Ω as possible.

DIGITAL PICTURE OF THE EVALUATION BOARD

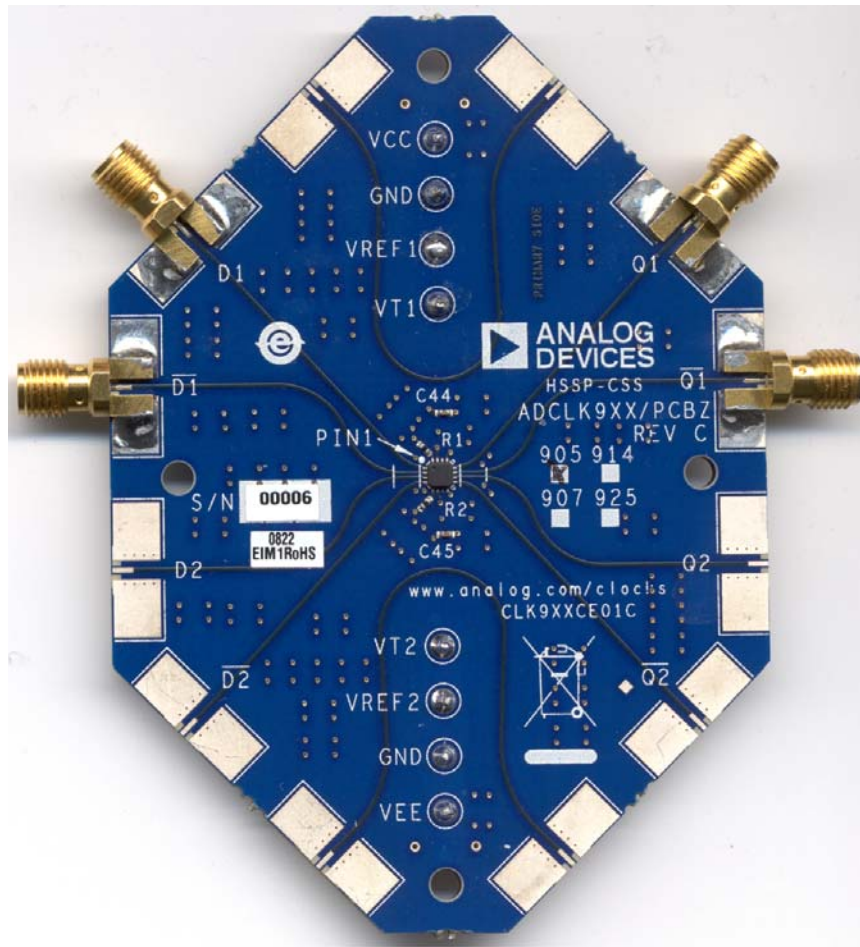

Figure 1. ADCLK905/ADCLK907/ADCLK925 Evaluation Board

TABLE OF CONTENTS

Package List	1	Recommended Board Setup	3
General Description	1	Clock Input Configuration	4
Digital Picture of the Evaluation Board	1	Evaluation Board Schematics and Artwork.....	5
Revision History	2	ESD Caution.....	7

REVISION HISTORY

9/09—Revision 0: Initial Version

RECOMMENDED BOARD SETUP

The recommended setup for the evaluation board is shown in Figure 2. Note that there is no LVPECL output termination on the evaluation board. LVPECL termination is accomplished via the 50 Ω input of the oscilloscope. To meet the standard LVPECL output termination ($V_{CC} - 2\text{ V}$ into $50\ \Omega$), V_{CC} is set to 2 V and V_{EE} is set to -1.3 V . This also meets the requirement for $V_{CC} - V_{EE} = 3.3\text{ V}$.

Table 1. Basic Equipment Required

Quantity	Description
1	Dual power supply
1	Signal source
1	High bandwidth oscilloscope
4	Matched high speed cables

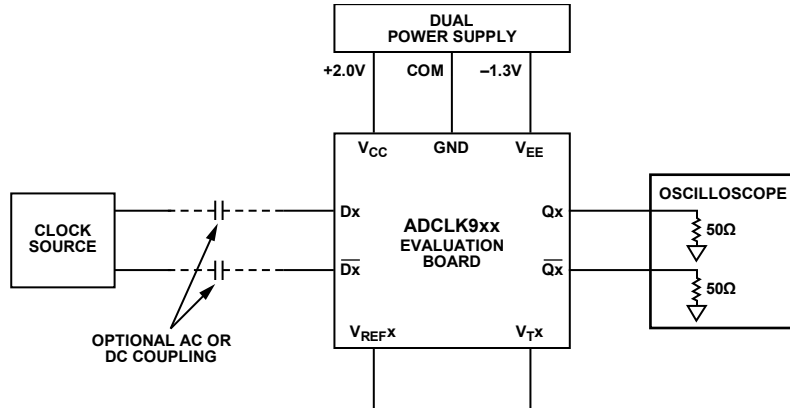

- NOTES**
1. FOR DC-COUPLED INPUTS, DISCONNECT V_{REFx} AND V_{Tx} .
 2. FOR AC-COUPLED INPUTS, CONNECT V_{REFx} AND V_{Tx} .

Figure 2. Recommended Setup for Device Evaluation

08182-002

CLOCK INPUT CONFIGURATION

The clock inputs of the [ADCLK905/ADCLK907/ADCLK925](#) on the evaluation board are dc-coupled to the SMA connectors. Therefore, the user must ac-couple the clock source, or the clock source must supply the appropriate dc common-mode voltage with adequate input swing.

It is recommended that the clock source be ac-coupled and that V_{REFX} and V_{TX} be tied together. For single-ended operation, ac-couple the unused input to ground with a 0.1 μ F capacitor. For more information about input configurations, refer to the data sheet for the ADCLK905/ADCLK907/ADCLK925.

Figure 3 to Figure 5 show block diagrams for the three devices.

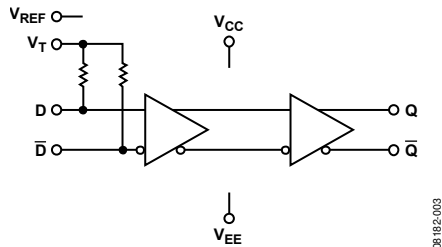

Figure 3. ADCLK905 1:1 Clock/Data Buffer

08182-003

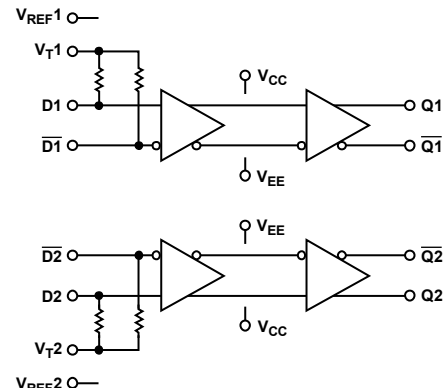

Figure 4. ADCLK907 Dual 1:1 Clock/Data Buffer

08182-004

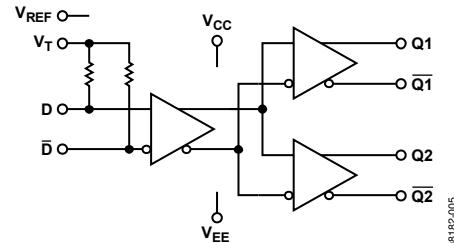

Figure 5. ADCLK925 1:2 Clock/Data Fanout Buffer

08182-005

Table 2. Jumper Connections

Jumper	ADCLK905/ADCLK925	ADCLK907
TP1 (GND)	Connect to GND	Connect to GND
TP2 (VCC)	Connect to 2.0 V	Connect to 2.0 V
TP3 (VEE)	Connect to -1.3 V	Connect to -1.3 V
TP4 (GND)	Connect to GND	Connect to GND
TP5 (VREF1)	Short T5 and T6 for input ac coupling, else no connection	Short T5 and T6 for input ac coupling, else no connection
TP6 (VT1)	Short T5 and T6 for input ac coupling, else no connection	Short T5 and T6 for input ac coupling, else no connection
TP7 (VT2)	No connection	Short T7 and T8 for input ac coupling, else no connection
TP8 (VREF2)	No connection	Short T7 and T8 for input ac coupling, else no connection

EVALUATION BOARD SCHEMATICS AND ARTWORK

900-28180

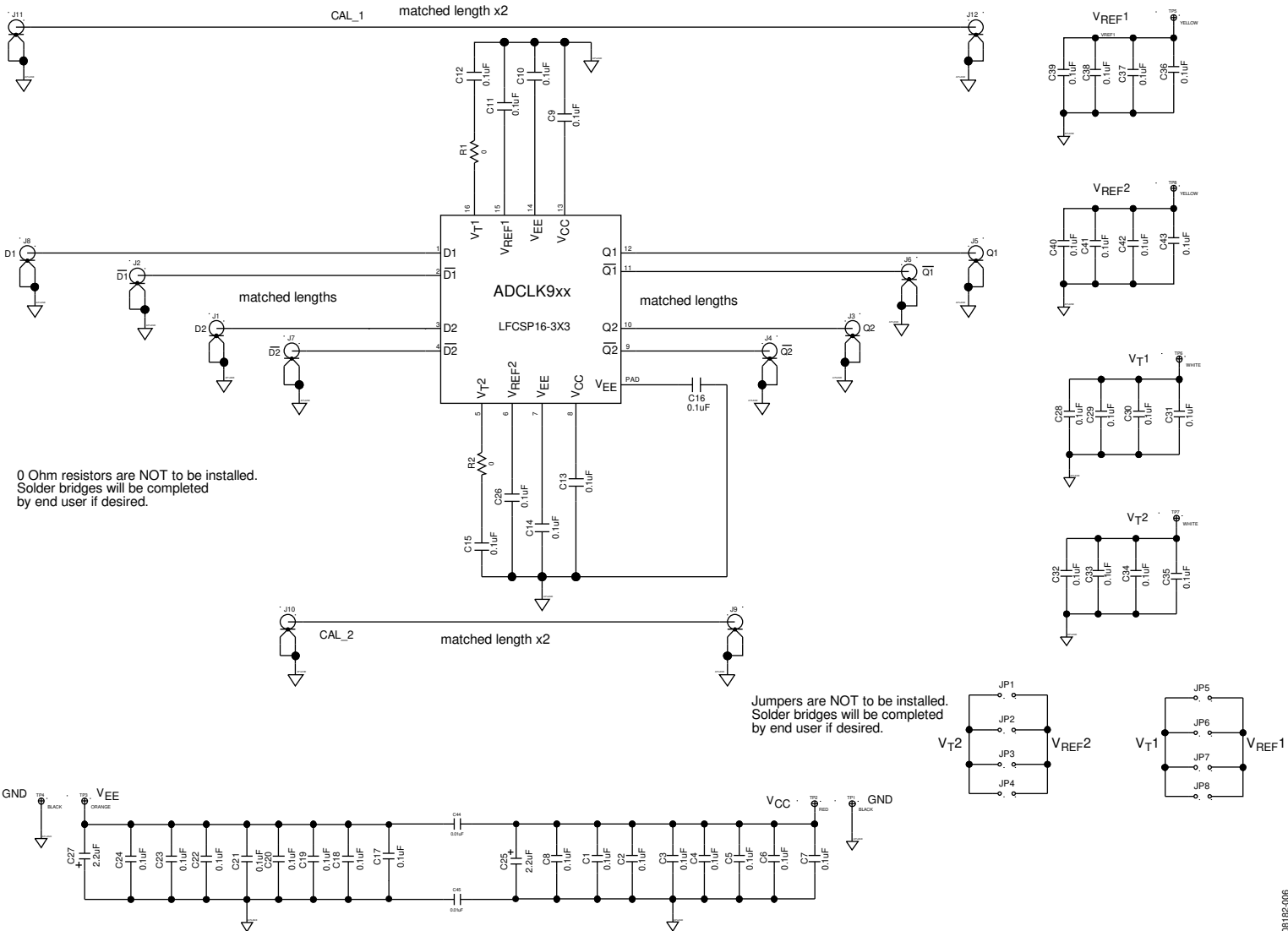

Figure 6. ADCLK905/ADCLK907/ADCLK925 Evaluation Board Schematic

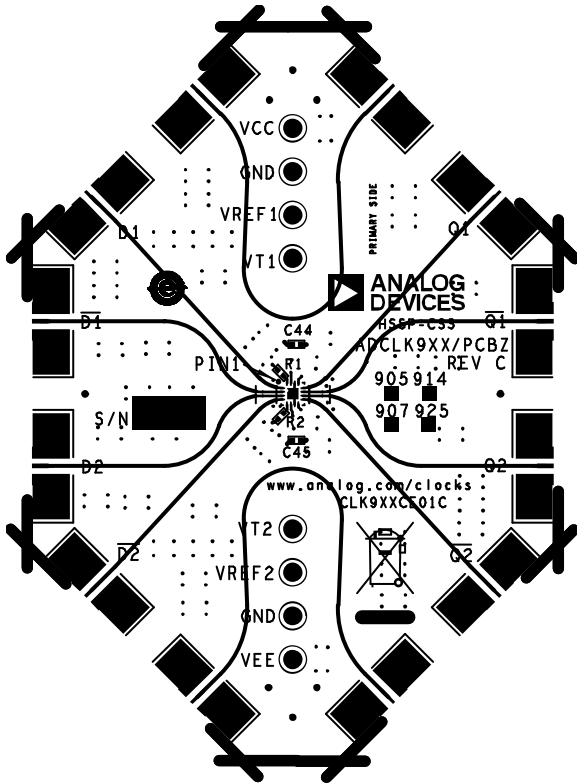

Figure 7. Top Trace Layer

08182-007

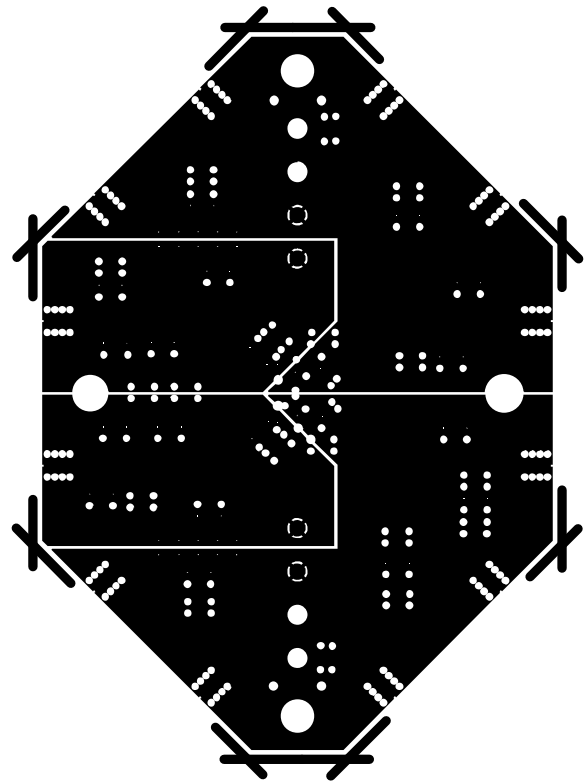

Figure 9. VREF and VT Plane Layers

08182-009

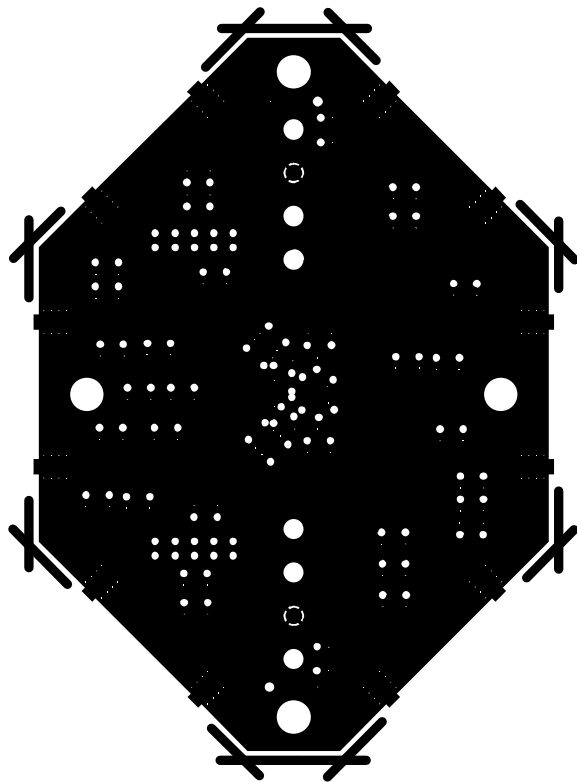

Figure 8. Ground Plane Layer

08182-008

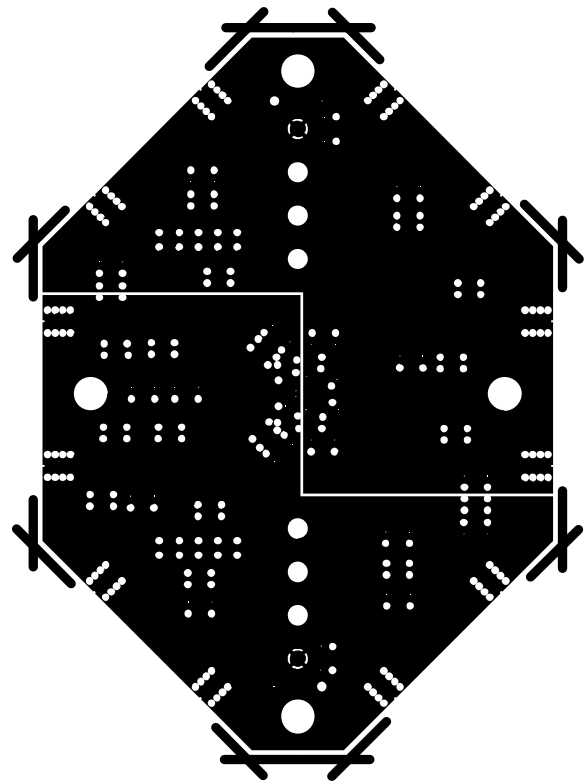

Figure 10. VCC and VEE Power Plane Layer

08182-010

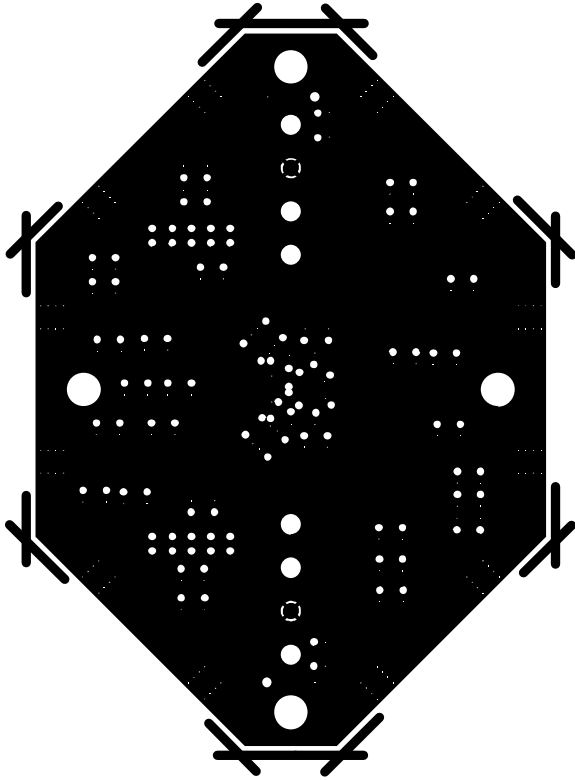

Figure 11. Second Ground Plane Layer

08182-011

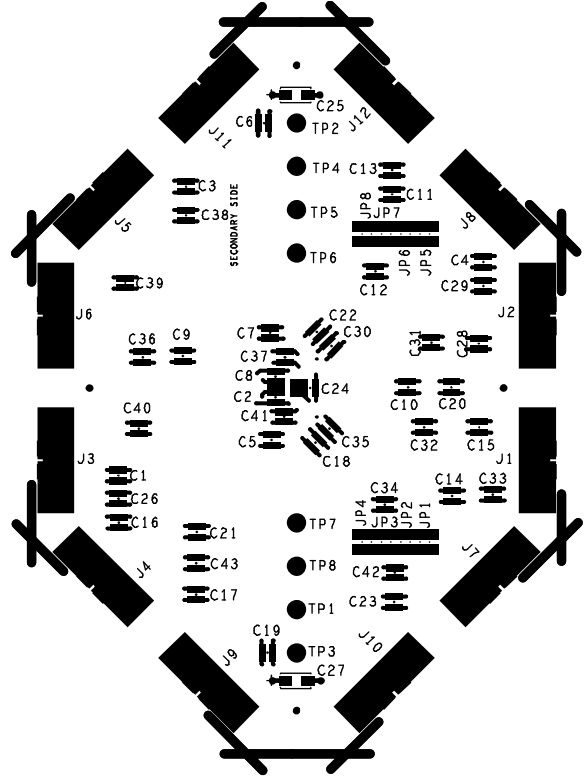

Figure 12. Bottom Trace Layer

08182-012

ESD CAUTION



ESD (electrostatic discharge) sensitive device.
 Charged devices and circuit boards can discharge without detection. Although this product features patented or proprietary protection circuitry, damage may occur on devices subjected to high energy ESD. Therefore, proper ESD precautions should be taken to avoid performance degradation or loss of functionality.

NOTES

Evaluation boards are only intended for device evaluation and not for production purposes. Evaluation boards are supplied "as is" and without warranties of any kind, express, implied, or statutory including, but not limited to, any implied warranty of merchantability or fitness for a particular purpose. No license is granted by implication or otherwise under any patents or other intellectual property by application or use of evaluation boards. Information furnished by Analog Devices is believed to be accurate and reliable. However, no responsibility is assumed by Analog Devices for its use, nor for any infringements of patents or other rights of third parties that may result from its use. Analog Devices reserves the right to change devices or specifications at any time without notice. Trademarks and registered trademarks are the property of their respective owners. Evaluation boards are not authorized to be used in life support devices or systems.