



Chipsmall Limited consists of a professional team with an average of over 10 year of expertise in the distribution of electronic components. Based in Hongkong, we have already established firm and mutual-benefit business relationships with customers from,Europe,America and south Asia,supplying obsolete and hard-to-find components to meet their specific needs.

With the principle of “Quality Parts,Customers Priority,Honest Operation,and Considerate Service”,our business mainly focus on the distribution of electronic components. Line cards we deal with include Microchip,ALPS,ROHM,Xilinx,Pulse,ON,Everlight and Freescale. Main products comprise IC,Modules,Potentiometer,IC Socket,Relay,Connector.Our parts cover such applications as commercial,industrial, and automotives areas.

We are looking forward to setting up business relationship with you and hope to provide you with the best service and solution. Let us make a better world for our industry!



## Contact us

Tel: +86-755-8981 8866 Fax: +86-755-8427 6832

Email & Skype: info@chipsmall.com Web: www.chipsmall.com

Address: A1208, Overseas Decoration Building, #122 Zhenhua RD., Futian, Shenzhen, China





# ADF4356\* PRODUCT PAGE QUICK LINKS

Last Content Update: 02/23/2017

---

## COMPARABLE PARTS

View a parametric search of comparable parts.

## EVALUATION KITS

- ADF4356 Evaluation Board

## DOCUMENTATION

### Data Sheet

- ADF4356: 6.8 GHz Wideband Synthesizer with Integrated VCO Data Sheet

### User Guides

- UG-1062: Evaluating the ADF4356 Microwave Wideband Synthesizer with Integrated VCO

## TOOLS AND SIMULATIONS

- ADIsimPLL™

## DESIGN RESOURCES

- ADF4356 Material Declaration
- PCN-PDN Information
- Quality And Reliability
- Symbols and Footprints

## DISCUSSIONS

View all ADF4356 EngineerZone Discussions.

## SAMPLE AND BUY

Visit the product page to see pricing options.

## TECHNICAL SUPPORT

Submit a technical question or find your regional support number.

## DOCUMENT FEEDBACK

Submit feedback for this data sheet.

---

## TABLE OF CONTENTS

Features .....	1	Register 4 .....	21
Applications .....	1	Register 5 .....	22
General Description .....	1	Register 6 .....	23
Functional Block Diagram .....	1	Register 7 .....	25
Revision History .....	2	Register 8 .....	26
Specifications .....	3	Register 9 .....	26
Timing Characteristics .....	5	Register 10 .....	27
Absolute Maximum Ratings .....	6	Register 11 .....	28
Transistor Count .....	6	Register 12 .....	28
ESD Caution .....	6	Register 13 .....	29
Pin Configuration and Function Descriptions .....	7	Register Initialization Sequence .....	29
Typical Performance Characteristics .....	9	Frequency Update Sequence .....	30
Theory of Operation .....	12	RF Synthesizer—A Worked Example .....	30
Reference Input Section .....	12	Reference Doubler and Reference Divider .....	31
RF N Divider .....	12	Spurious Optimization and Fast Lock .....	31
Phase Frequency Detector (PFD) and Charge Pump .....	13	Optimizing Jitter .....	31
MUXOUT and Lock Detect .....	13	Spur Mechanisms .....	31
Input Shift Registers .....	13	Lock Time .....	31
Program Modes .....	14	Applications Information .....	33
VCO .....	14	Power Supplies .....	33
Output Stage .....	14	Printed Circuit Board (PCB) Design Guidelines for a Chip-Scale Package .....	33
Register Maps .....	16	Output Matching .....	34
Register 0 .....	18	Outline Dimensions .....	35
Register 1 .....	19	Ordering Guide .....	35
Register 2 .....	19		
Register 3 .....	20		

## REVISION HISTORY

10/2016—Revision 0—Initial Version

## SPECIFICATIONS

$AV_{DD} = DV_{DD} = V_{RF} = 3.3 \text{ V} \pm 5\%$ ,  $4.75 \text{ V} \leq V_P = V_{VCO} \leq 5.25 \text{ V}$ ,  $A_{GND} = CP_{GND} = A_{GNDVCO} = SD_{GND} = A_{GNDRF} = 0 \text{ V}$ ,  $R_{SET} = 5.1 \text{ k}\Omega$ , dBm referred to  $50 \text{ }\Omega$ ,  $T_A = T_{MIN}$  to  $T_{MAX}$ , unless otherwise noted.

Table 1.

Parameter	Symbol	Min	Typ	Max	Unit	Test Conditions/Comments
<b>REF<sub>IN</sub>A/REF<sub>IN</sub>B CHARACTERISTICS</b>						
Input Frequency Range						For $f < 10 \text{ MHz}$ , ensure slew rate $> 21 \text{ V}/\mu\text{s}$
Single-Ended Mode		10		250	MHz	
Differential Mode		10		600	MHz	
Input Sensitivity						
Single-Ended Mode		0.4		$AV_{DD}$	V p-p	REF <sub>IN</sub> A biased at $AV_{DD}/2$ ; ac coupling ensures $AV_{DD}/2$ bias
Differential Mode		0.4		1.8	V p-p	LVDS and LVPECL compatible, REF <sub>IN</sub> A/ REF <sub>IN</sub> B biased at 2.1 V; ac coupling ensures 2.1 V bias
Input Capacitance						
Single-Ended Mode			6.9		pF	
Differential Mode			1.4		pF	
Input Current				$\pm 100$	$\mu\text{A}$	Single-ended reference programmed
				$\pm 250$	$\mu\text{A}$	Differential reference programmed
Phase Frequency Detector				125	MHz	
<b>CHARGE PUMP (CP)</b>						
CP Current, Sink/Source	$I_{CP}$					$R_{SET} = 5.1 \text{ k}\Omega$ , this resistor is internal in the ADF4356
High Value			4.8		mA	
Low Value			0.3		mA	
$R_{SET}$ Range			5.1		k $\Omega$	Fixed
Current Matching			3		%	$0.5 \text{ V} \leq V_{CP1} \leq V_P - 0.5 \text{ V}$
$I_{CP}$ vs. $V_{CP}$			3		%	$0.5 \text{ V} \leq V_{CP1} \leq V_P - 0.5 \text{ V}$
$I_{CP}$ vs. Temperature			1.5		%	$V_{CP1} = 2.5 \text{ V}$
<b>LOGIC INPUTS</b>						
Input Voltage						
High	$V_{INH}$	1.5		$DV_{DD}$	V	
Low	$V_{INL}$			0.6	V	
Input Current	$I_{INH}/I_{INL}$			$\pm 1$	$\mu\text{A}$	
Input Capacitance	$C_{IN}$		3.0		pF	
<b>LOGIC OUTPUTS</b>						
Output High Voltage	$V_{OH}$	$DV_{DD} - 0.4$			V	
		1.5	1.8		V	1.8 V output selected
Output High Current	$I_{OH}$			500	$\mu\text{A}$	
Output Low Voltage	$V_{OL}$			0.4	V	$I_{OL}^2 = 500 \text{ }\mu\text{A}$
<b>POWER SUPPLIES</b>						
Analog Power	$AV_{DD}$	3.15	3.3	3.45	V	See Table 7 and Table 8
Digital Power and RF Supply Voltage	$DV_{DD}, V_{RF}$		$AV_{DD}$			Voltages must equal $AV_{DD}$
CP and VCO Supply Voltage	$V_P, V_{VCO}$	4.75	5.0	5.25	V	$V_P$ must equal $V_{VCO}$
CP Supply Power Current	$I_P$		8	9	mA	
$DI_{DD} + AI_{DD}^3$			82	92	mA	
Output Dividers			6 to 36		mA	Each output divide by 2 consumes 6 mA
Supply Current	$I_{VCO}$		70	90	mA	

Parameter	Symbol	Min	Typ	Max	Unit	Test Conditions/Comments
RF <sub>OUTA+</sub> /RF <sub>OUTA-</sub> Supply Current	I <sub>RFOUT±</sub>		22 33 44 55	27 38 49 60	mA mA mA mA	RF Output A enabled/RF Output B disabled -4 dBm setting -1 dBm setting 2 dBm setting 5 dBm setting
RF <sub>OUTA+</sub> /RF <sub>OUTA-</sub> Plus RF <sub>OUTB+</sub> /RF <sub>OUTB-</sub> Supply Current	I <sub>RFOUT±</sub>		48 65 82 99	56 74 91 108	mA mA mA mA	RF Output A enabled/RF Output B enabled -4 dBm setting -1 dBm setting 2 dBm setting 5 dBm setting
Low Power Sleep Mode			5 20		mA mA	Hardware power-down selected Software power-down selected
<b>RF OUTPUT CHARACTERISTICS</b>						
VCO Frequency Range		3400		6800	MHz	Fundamental VCO range
RF Output Frequency		53.125		6800	MHz	
VCO Sensitivity	K <sub>V</sub>		25		MHz/V	
Frequency Pushing (Open-Loop)			12		MHz/V	
Frequency Pulling (Open-Loop)			0.5		MHz	Voltage standing wave ratio (VSWR) = 2:1 RF <sub>OUTA+</sub> /RF <sub>OUTA-</sub>
Harmonic Content						
Second			-26		dBc	Fundamental VCO output (RF <sub>OUTA+</sub> )
Third			-29		dBc	Divided VCO output (RF <sub>OUTA+</sub> )
Fourth			-32		dBc	Fundamental VCO output (RF <sub>OUTA+</sub> )
Fifth			-14		dBc	Divided VCO output (RF <sub>OUTA+</sub> )
RF Output A Power <sup>4</sup>			7		dBm	RF <sub>OUTA+</sub> = 1 GHz; 7.4 nH inductor to V <sub>RF</sub>
			-2		dBm	RF <sub>OUTA+</sub> = 6.8 GHz; 7.4 nH inductor to V <sub>RF</sub>
Power Variation			±1		dB	RF <sub>OUTA+</sub> = 5 GHz
Power Variation over Frequency			±5		dB	RF <sub>OUTA+</sub> = 1 GHz to 6.8 GHz
RF Output B Power <sup>4</sup>			4		dBm	RF <sub>OUTB+</sub> = 1 GHz; 7.4 nH inductor to V <sub>RF</sub>
			-2		dBm	RF <sub>OUTB+</sub> = 6.8 GHz; 7.4 nH inductor to V <sub>RF</sub>
Power Variation			±1		dB	RF <sub>OUTB+</sub> = 5 GHz
Power Variation over Frequency			±5		dB	RF <sub>OUTB+</sub> = 1 GHz to 6.8 GHz
Level of Signal with RF Output Disabled			-53		dBm	RF <sub>OUTA+</sub> = 1 GHz
			-20		dBm	RF <sub>OUTA+</sub> = 6.8 GHz
<b>NOISE CHARACTERISTICS</b>						
Fundamental VCO Phase Noise Performance						VCO noise in open-loop conditions
			-115		dBc/Hz	100 kHz offset from 3.4 GHz carrier
			-135		dBc/Hz	800 kHz offset from 3.4 GHz carrier
			-137		dBc/Hz	1 MHz offset from 3.4 GHz carrier
			-155		dBc/Hz	10 MHz offset from 3.4 GHz carrier
			-113		dBc/Hz	100 kHz offset from 5.0 GHz carrier
			-133		dBc/Hz	800 kHz offset from 5.0 GHz carrier
			-135		dBc/Hz	1 MHz offset from 5.0 GHz carrier
			-153		dBc/Hz	10 MHz offset from 5.0 GHz carrier
			-110		dBc/Hz	100 kHz offset from 6.8 GHz carrier
			-130		dBc/Hz	800 kHz offset from 6.8 GHz carrier
			-132		dBc/Hz	1 MHz offset from 6.8 GHz carrier
			-150		dBc/Hz	10 MHz offset from 6.8 GHz carrier

Parameter	Symbol	Min	Typ	Max	Unit	Test Conditions/Comments
Normalized In-Band Phase Noise Floor						
Fractional Channel <sup>5</sup>			-225		dBc/Hz	10 kHz offset; normalized to 1 GHz
Integer Channel <sup>6</sup>			-227		dBc/Hz	
Normalized 1/f Noise, $PN_{1/f}$ <sup>7</sup>			-121		dBc/Hz	
Integrated RMS Jitter (1 kHz to 20 MHz) <sup>8</sup>			97		fs	
Spurious Signals Due to PFD Frequency			-85		dBc	

<sup>1</sup>  $V_{CP}$  is the voltage at the  $CP_{OUT}$  pin.  
<sup>2</sup>  $I_{OL}$  is the output low current.  
<sup>3</sup>  $T_A = 25^\circ C$ ;  $AV_{DD} = DV_{DD} = V_{RF} = 3.3 V$ ;  $V_{VCO} = V_P = 5.0 V$ ; prescaler = 4/5;  $f_{REFIN} = 122.88 MHz$ ;  $f_{PFD} = 61.44 MHz$ ; and  $f_{RF} = 1650 MHz$ .  
<sup>4</sup> RF output power using the [EV-ADF4356SD1Z](#) evaluation board is measured into a spectrum analyzer. Unused RF output pins are terminated in 50  $\Omega$ .  
<sup>5</sup> Use this value to calculate the phase noise for any application. To calculate in-band phase noise performance as seen at the VCO output, use the following formula:  
 $-225 + 10\log(f_{PFD}) + 20\log N$ . The value given is the lowest noise mode for the fractional channel.  
<sup>6</sup> Use this value to calculate the phase noise for any application. To calculate in-band phase noise performance as seen at the VCO output, use the following formula:  
 $-227 + 10\log(f_{PFD}) + 20\log N$ . The value given is the lowest noise mode for the integer channel.  
<sup>7</sup> The PLL phase noise is composed of 1/f (flicker) noise plus the normalized PLL noise floor. The formula for calculating the 1/f noise contribution at an RF frequency ( $f_{RF}$ ) and at a frequency offset (f) is given by  $PN = P_{1/f} + 10\log(10 kHz/f) + 20\log(f_{RF}/1 GHz)$ . Both the normalized phase noise floor and flicker noise are modeled in the [ADIsimPLL](#) design tool.  
<sup>8</sup> Integrated RMS jitter using the [EV-ADF4356SD1Z](#) evaluation board is measured into a spectrum analyzer. The [EV-ADF4356SD1Z](#) evaluation board is configured to accept a single ended REF<sub>IN</sub> (SMA 100) = 160 MHz, VCO frequency = 6 GHz, PFD frequency = 80 MHz, charge pump current = 0.9 mA, and bleed current is off. The loop filter is configured for an 80 kHz loop filter bandwidth. Unused RF output pins are terminated in 50  $\Omega$ .

**TIMING CHARACTERISTICS**

$AV_{DD} = DV_{DD} = V_{RF} = 3.3 V \pm 5\%$ ,  $4.75 V \leq V_P = V_{VCO} \leq 5.25 V$ ,  $A_{GND} = CP_{GND} = A_{GNDVCO} = SD_{GND} = A_{GNDRF} = 0 V$ ,  $R_{SET} = 5.1 k\Omega$ , dBm referred to 50  $\Omega$ ,  $T_A = T_{MIN}$  to  $T_{MAX}$ , unless otherwise noted.

Table 2. Write Timing

Parameter	Limit	Unit	Description
$f_{CLK}$	50	MHz max	Serial peripheral interface CLK frequency
$t_1$	10	ns min	LE setup time
$t_2$	5	ns min	DATA to CLK setup time
$t_3$	5	ns min	DATA to CLK hold time
$t_4$	10	ns min	CLK high duration
$t_5$	10	ns min	CLK low duration
$t_6$	10	ns min	CLK to LE setup time
$t_7$	20 or $(2/f_{PFD})$ , whichever is longer	ns min	LE pulse width

**Write Timing Diagram**

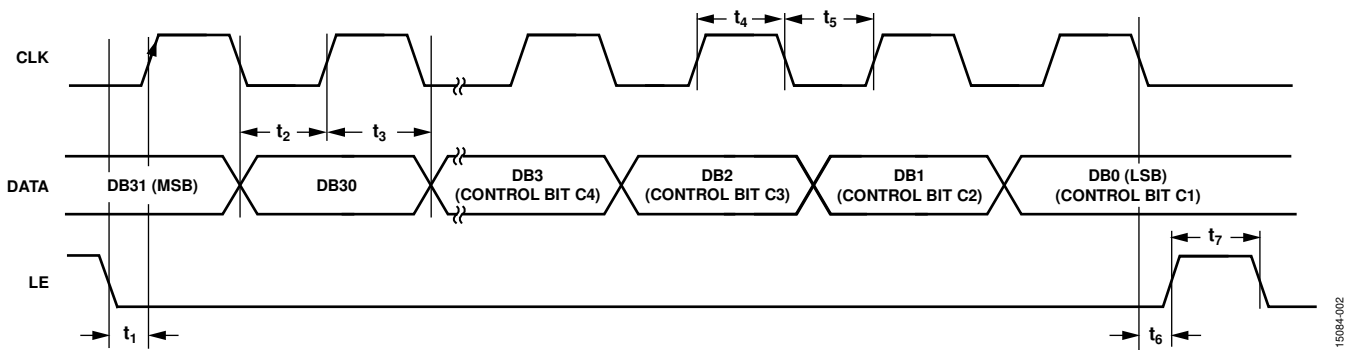

Figure 2. Write Timing Diagram

15094-012

## ABSOLUTE MAXIMUM RATINGS

T<sub>A</sub> = 25°C, unless otherwise noted.

Table 3.

Parameter	Rating
V <sub>RF</sub> , DV <sub>DD</sub> , AV <sub>DD</sub> to GND <sup>1</sup>	−0.3 V to +3.6 V
AV <sub>DD</sub> to DV <sub>DD</sub>	−0.3 V to +0.3 V
V <sub>P</sub> , V <sub>VCO</sub> to GND <sup>1</sup>	−0.3 V to +5.8 V
CP <sub>OUT</sub> to GND <sup>1</sup>	−0.3 V to V <sub>P</sub> + 0.3 V
Digital Input/Output Voltage to GND <sup>1</sup>	−0.3 V to DV <sub>DD</sub> + 0.3 V
Analog Input/Output Voltage to GND <sup>1</sup>	−0.3 V to AV <sub>DD</sub> + 0.3 V
REF <sub>IN</sub> A, REF <sub>IN</sub> B to GND <sup>1</sup>	−0.3 V to AV <sub>DD</sub> + 0.3 V
REF <sub>IN</sub> A to REF <sub>IN</sub> B	±2.1 V
Operating Temperature Range	−40°C to +85°C
Storage Temperature Range	−65°C to +125°C
Maximum Junction Temperature	150°C
Reflow Soldering	
Peak Temperature	260°C
Time at Peak Temperature	40 sec
Electrostatic Discharge (ESD)	
Charged Device Model	1000 V
Human Body Model	2000 V

<sup>1</sup> GND = A<sub>GND</sub> = SD<sub>GND</sub> = A<sub>GNDRF</sub> = A<sub>GNDVCO</sub> = CP<sub>GND</sub> = 0 V.

Stresses at or above those listed under Absolute Maximum Ratings may cause permanent damage to the product. This is a stress rating only; functional operation of the product at these or any other conditions above those indicated in the operational section of this specification is not implied. Operation beyond the maximum operating conditions for extended periods may affect product reliability.

The ADF4356 is a high performance RF integrated circuit with an ESD rating of 2 kV and is ESD sensitive. Take proper precautions for handling and assembly.

### THERMAL RESISTANCE

Thermal performance is directly linked to printed circuit board (PCB) design and operating environment. Careful attention to PCB thermal design is required.

Table 4. Thermal Resistance

Package Type	θ <sub>JA</sub>	Unit
CP-32-12 <sup>1</sup>	27.3	°C/W

<sup>1</sup> Test Condition 1: thermal impedance simulated values are based on use of a PCB with the thermal impedance paddle soldered to GND<sub>1</sub>.

### TRANSISTOR COUNT

The transistor count for the ADF4356 is 134,486 (CMOS) and 3874 (bipolar).

### ESD CAUTION



**ESD (electrostatic discharge) sensitive device.** Charged devices and circuit boards can discharge without detection. Although this product features patented or proprietary protection circuitry, damage may occur on devices subjected to high energy ESD. Therefore, proper ESD precautions should be taken to avoid performance degradation or loss of functionality.



# PIN CONFIGURATION AND FUNCTION DESCRIPTIONS

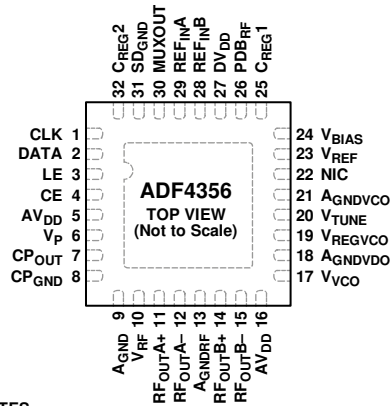

- NOTES  
 1. NIC = NOT INTERNALLY CONNECTED.  
 2. THE EXPOSED PAD MUST BE CONNECTED TO A\_GND-

Figure 3. Pin Configuration

Table 5. Pin Function Descriptions

Pin No.	Mnemonic	Description
1	CLK	Serial Clock Input. Data is clocked into the 32-bit shift register on the CLK rising edge. This input is a high impedance CMOS input.
2	DATA	Serial Data Input. The serial data is loaded most significant bit (MSB) first with the four LSBs as the control bits. This input is a high impedance CMOS input.
3	LE	Load Enable, CMOS Input. When LE goes high, the data stored in the shift register is loaded into the register that is selected by the four LSBs.
4	CE	Chip Enable. A logic low on this pin powers down the device and puts the charge pump into three-state mode. A logic high on this pin powers up the device, depending on the status of the power-down bits.
5, 16	AV <sub>DD</sub>	Analog Power Supplies. These pins range from 3.15 V to 3.45 V. Connect decoupling capacitors to the analog ground plane as close to these pins as possible. AV <sub>DD</sub> must have the same value as DV <sub>DD</sub> .
6	V <sub>P</sub>	Charge Pump Power Supply. V <sub>P</sub> must have the same value as V <sub>VCO</sub> . Connect decoupling capacitors to the ground plane as close to this pin as possible.
7	CP <sub>OUT</sub>	Charge Pump Output. When enabled, this output provides ±I <sub>CP</sub> to the external loop filter. The output of the loop filter is connected to V <sub>TUNE</sub> to drive the internal VCO.
8	CP <sub>GND</sub>	Charge Pump Ground. This output is the ground return pin for CP <sub>OUT</sub> .
9	A <sub>GND</sub>	Analog Ground. This pin is the ground return pin for AV <sub>DD</sub> .
10	V <sub>RF</sub>	Power Supply for the RF Output. Connect decoupling capacitors to the analog ground plane as close to this pin as possible. V <sub>RF</sub> must have the same value as AV <sub>DD</sub> .
11	RF <sub>OUT</sub> A+	VCO Output. The output level is programmable. The VCO fundamental output or a divided down version is available.
12	RF <sub>OUT</sub> A-	Complementary VCO Output. The output level is programmable. The VCO fundamental output or a divided down version is available.
13	A <sub>GND</sub> RF	RF Output Stage Ground. This pin is the ground return pin for the RF output stage.
14	RF <sub>OUT</sub> B+	Auxiliary VCO Output. The output level is programmable. The VCO fundamental output or a divided down version is available.
15	RF <sub>OUT</sub> B-	Complementary Auxiliary VCO Output. The output level is programmable. The VCO fundamental output or a divided down version is available.
17	V <sub>VCO</sub>	Power Supply for the VCO. The voltage on this pin ranges from 4.75 V to 5.25 V. Place decoupling capacitors to the analog ground plane as close to this pin as possible.
18, 21	A <sub>GND</sub> VCO	VCO Ground. This pin is the ground return path for the VCO.
19	V <sub>REG</sub> VCO	VCO Compensation Node. Connect decoupling capacitors to the ground plane as close to this pin as possible. Connect V <sub>REG</sub> VCO directly to V <sub>VCO</sub> .

Pin No.	Mnemonic	Description
20	V <sub>TUNE</sub>	Control Input to the VCO. This voltage determines the output frequency and is derived from filtering the C <sub>P</sub> <sub>OUT</sub> output voltage. The capacitance at this pin (V <sub>TUNE</sub> input capacitance) is 9 pF.
22	NIC	No Internal Connection. For existing designs that currently use the ADF4355, to upgrade to the ADF4356, the R <sub>SET</sub> resistor can be left connected to this pin.
23	V <sub>REF</sub>	Internal Compensation Node. DC biased at half the tuning range. Connect decoupling capacitors to the ground plane as close to this pin as possible.
24	V <sub>BIAS</sub>	Reference Voltage. Connect a 100 nF decoupling capacitor to the ground plane as close to this pin as possible.
25, 32	C <sub>REG1</sub> , C <sub>REG2</sub>	Outputs from the LDO Regulator. C <sub>REG1</sub> and C <sub>REG2</sub> are the supply voltages to the digital circuits. Nominal voltage of 1.8 V. Decoupling capacitors of 100 nF connected to A <sub>GND</sub> are required for these pins.
26	PDB <sub>RF</sub>	RF Power-Down. A logic low on this pin mutes the RF outputs. This mute function is also software-controllable. Do not leave this pin floating.
27	DV <sub>DD</sub>	Digital Power Supply. This pin must be at the same voltage as AV <sub>DD</sub> . Place decoupling capacitors to the ground plane as close to this pin as possible.
28	REF <sub>INB</sub>	Complementary Reference Input. If unused, ac couple this pin to A <sub>GND</sub> .
29	REF <sub>INA</sub>	Reference Input.
30	MUXOUT	Multiplexer Output. The multiplexer output allows the digital lock detect, the analog lock detect, scaled RF, or the scaled reference frequency to be externally accessible.
31	SD <sub>GND</sub>	Digital $\Sigma$ - $\Delta$ Modulator Ground. SD <sub>GND</sub> is the ground return path for the $\Sigma$ - $\Delta$ modulator.
	EP	Exposed Pad. The exposed pad must be connected to A <sub>GND</sub> .

### TYPICAL PERFORMANCE CHARACTERISTICS

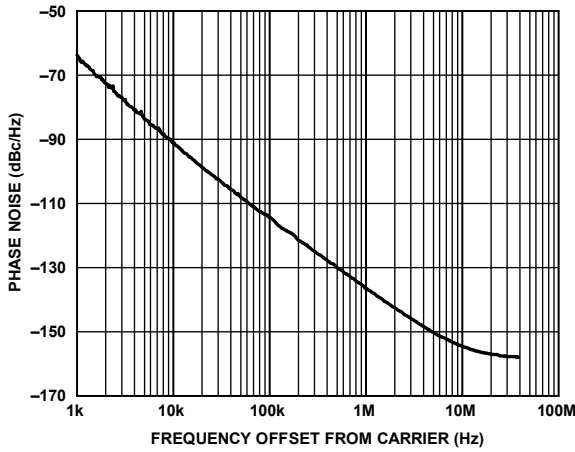

Figure 4. Open-Loop VCO Phase Noise, 3.4 GHz

15084-004

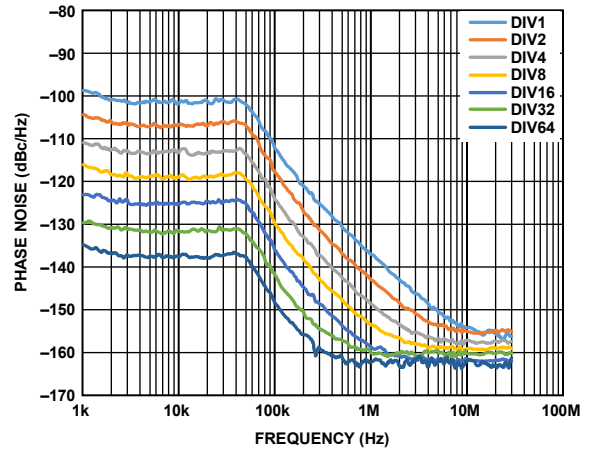

Figure 7. Closed-Loop Phase Noise,  $R_{FoutB+}$  (100 nH Inductors), Fundamental VCO and Dividers, VCO = 3.4 GHz, PFD = 61.44 MHz, Loop Bandwidth = 40 kHz

15084-007

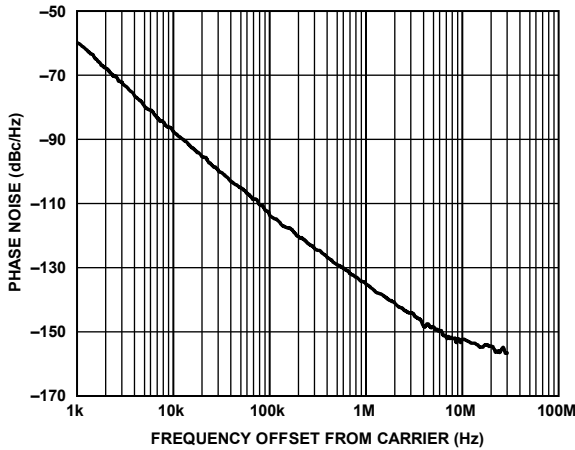

Figure 5. Open-Loop VCO Phase Noise, 5.0 GHz

15084-005

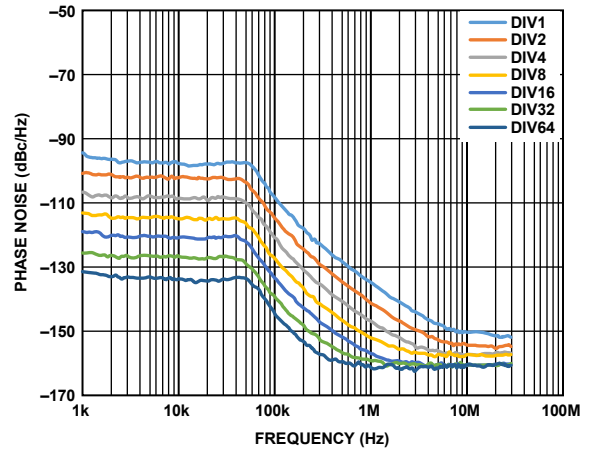

Figure 8. Closed-Loop Phase Noise,  $R_{FoutB+}$  (100 nH Inductors), Fundamental VCO and Dividers, VCO = 5.0 GHz, PFD = 61.44 MHz, Loop Bandwidth = 40 kHz

15084-008

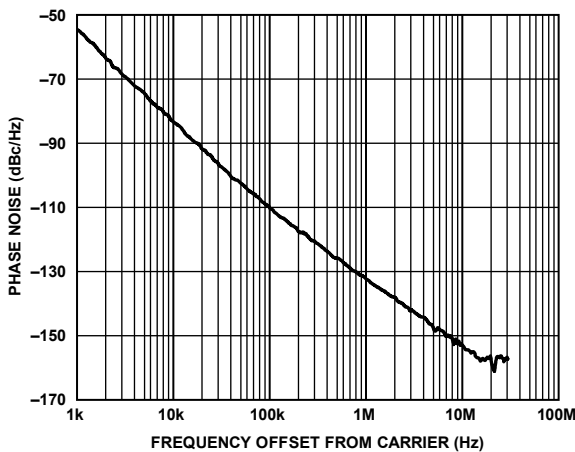

Figure 6. Open-Loop VCO Phase Noise, 6.8 GHz

15084-006

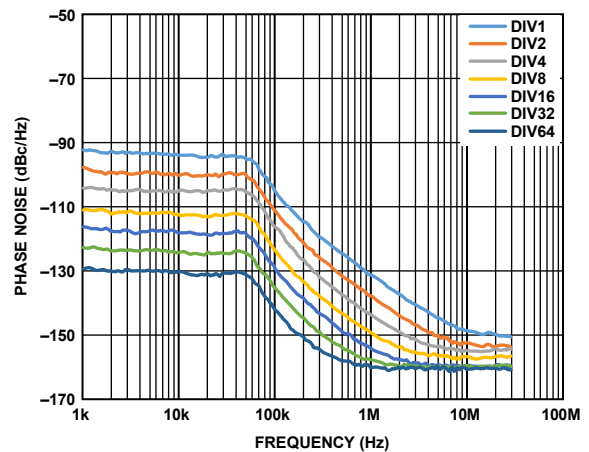

Figure 9. Closed-Loop Phase Noise,  $R_{FoutB+}$  (100 nH Inductors), Fundamental VCO and Dividers, VCO = 6.8 GHz, PFD = 61.44 MHz, Loop Bandwidth = 40 kHz

15084-009

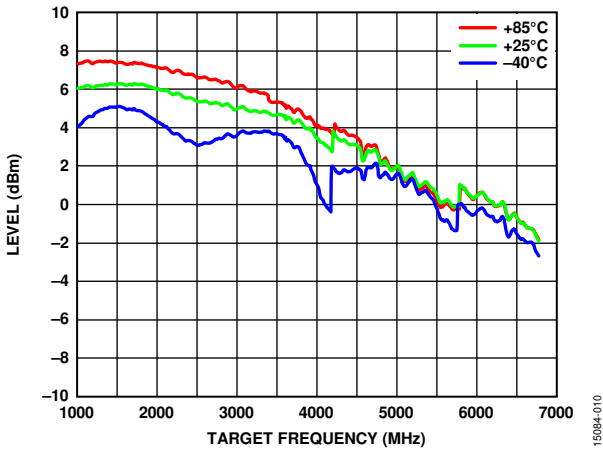

Figure 10. Output Power vs. Frequency,  $RF_{OUTA+}/RF_{OUTA-}$  (7.4 nH Inductors, 10 pF AC Coupling Capacitors, Board Measurement)

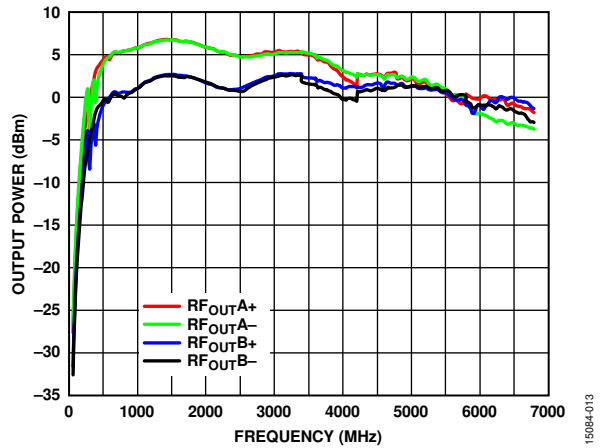

Figure 13.  $RF_{OUTA+}/RF_{OUTA-}$  Power vs.  $RF_{OUTB+}/RF_{OUTB-}$  Power (7.4 nH Inductors, 10 pF AC Coupling Capacitors, Board Measurement)

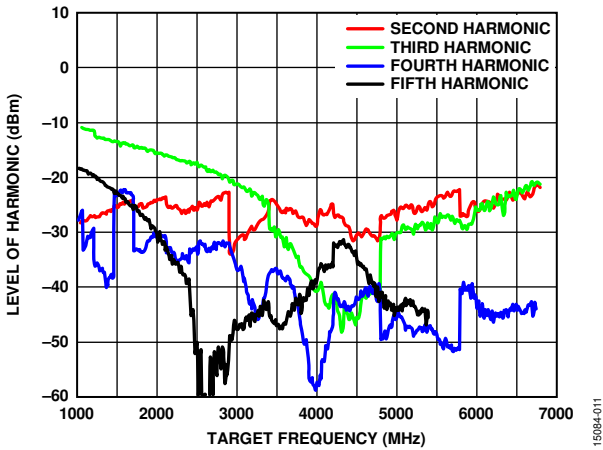

Figure 11.  $RF_{OUTA+}/RF_{OUTA-}$  Harmonics vs. Frequency (7.4 nH Inductors, 10 pF AC Coupling Capacitors, Board Measurement)

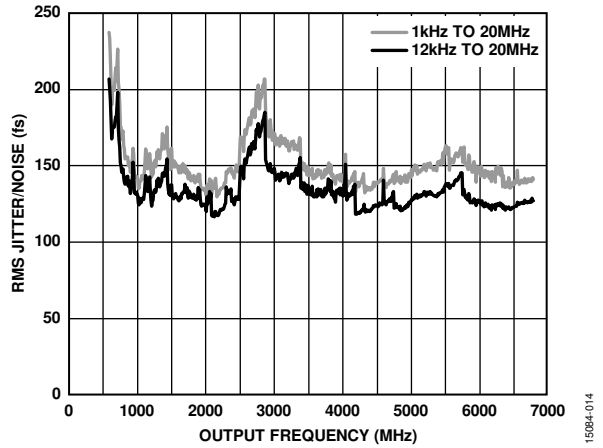

Figure 14. RMS Jitter/Noise vs. Output Frequency, PFD Frequency = 61.44 MHz, Loop Filter = 40 kHz

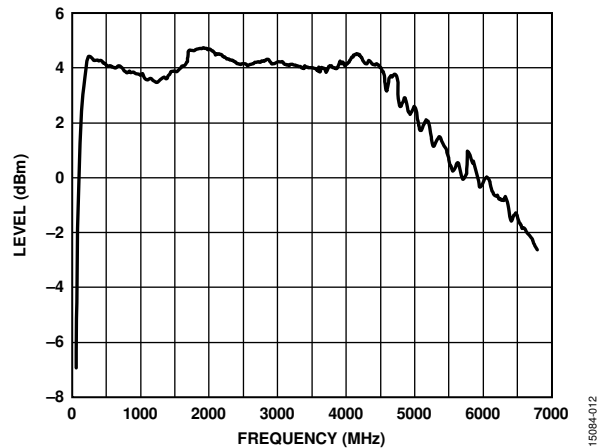

Figure 12.  $RF_{OUTB+}/RF_{OUTB-}$  Power vs. Frequency (100 nH Inductors, 10 pF AC Coupling Capacitors, Board Measurement)

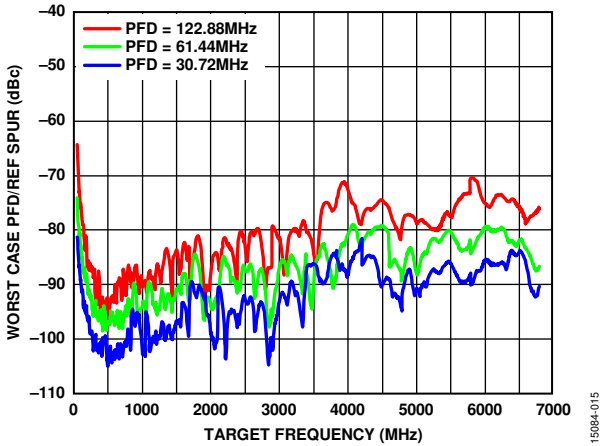

Figure 15. PFD Spur Amplitude vs.  $RF_{OUTA+}/RF_{OUTA-}$  Output Frequency, PFD = 30.72 MHz, PFD = 61.44 MHz, PFD = 122.88 MHz, Loop Filter = 40 kHz

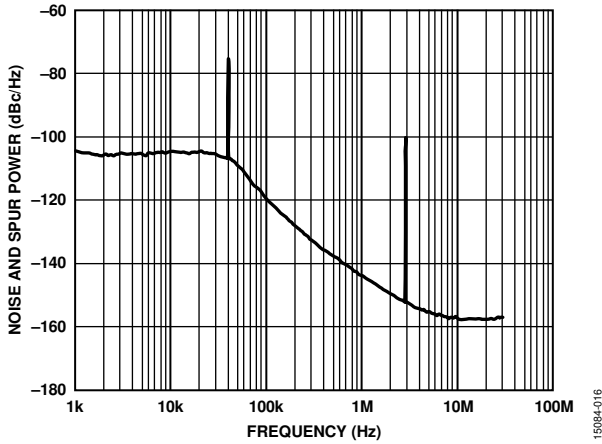

Figure 16. Fractional-N Spur Performance, GSM1800 Band,  $RF_{OUTA+} = 1550.2$  MHz,  $REF_{IN} = 122.88$  MHz,  $PFD = 61.44$  MHz, Output Divide by 4 Selected, Loop Filter Bandwidth = 40 kHz, Channel Spacing = 20 kHz

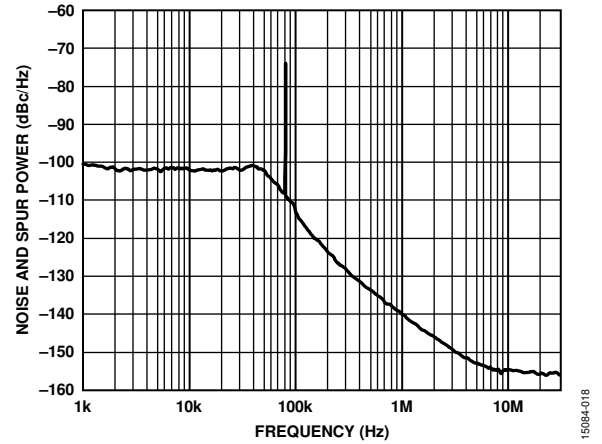

Figure 18. Fractional-N Spur Performance,  $RF_{OUTA+} = 2.591$  GHz,  $REF_{IN} = 122.88$  MHz,  $PFD = 61.44$  MHz, Output Divide by 2 Selected, Loop Filter Bandwidth = 40 kHz, Channel Spacing = 20 kHz

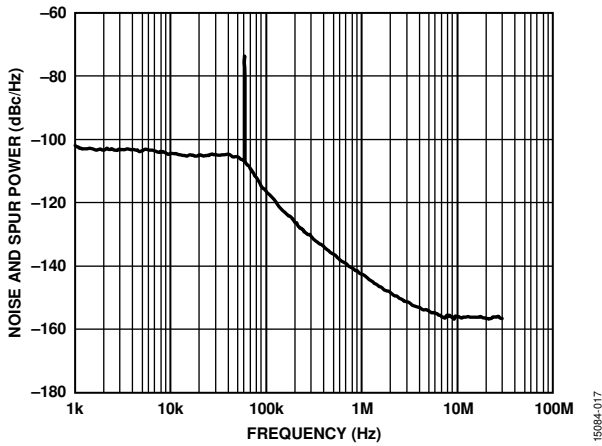

Figure 17. Fractional-N Spur Performance, W-CDMA Band,  $RF_{OUTA+} = 2113.5$  MHz,  $REF_{IN} = 122.88$  MHz,  $PFD = 61.44$  MHz, Output Divide by 2 Selected, Loop Filter Bandwidth = 40 kHz, Channel Spacing = 20 kHz

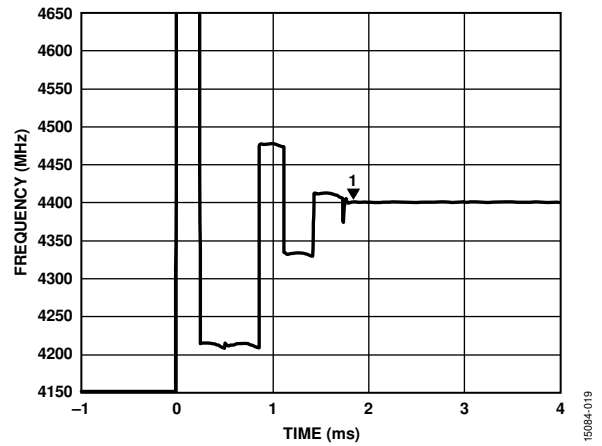

Figure 19. Lock Time for 250 MHz Jump from 4150 MHz to 4400 MHz, Loop Bandwidth = 23 kHz

## THEORY OF OPERATION

### REFERENCE INPUT SECTION

Figure 20 shows the reference input stage. The reference input can accept both single-ended and differential signals. Use the reference mode bit (Register 4, Bit DB9) to select the signal. To use a differential signal on the reference input, program this bit high. In this case, SW1 and SW2 are open, SW3 and SW4 are closed, and the current source that drives the differential pair of transistors switches on. The differential signal buffers and provides an emitter-coupled logic (ECL) to the CMOS converter. When a single-ended signal is used as the reference, program Bit DB9 in Register 4 to 0. Connect the single-ended reference signal to REF<sub>IN</sub>A. In this case, SW1 and SW2 are closed, SW3 and SW4 are open, and the current source that drives the differential pair of transistors switches off.

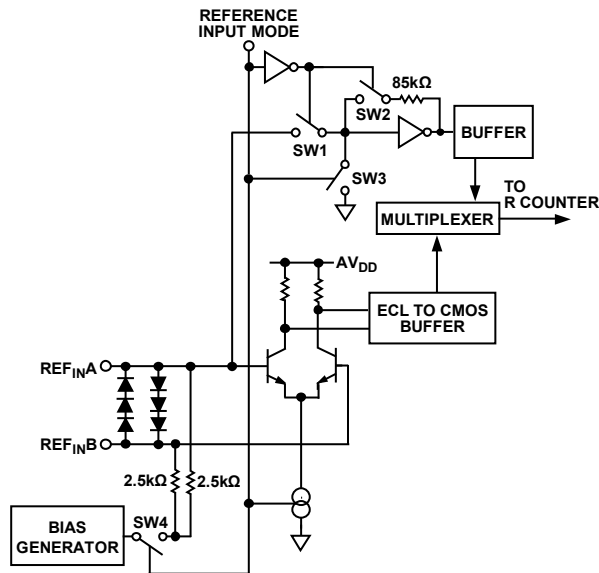

Figure 20. Reference Input Stage, Differential Mode

### RF N DIVIDER

The RF N divider allows a division ratio in the PLL feedback path. Determine the division ratio by the INT, FRAC1, FRAC2, and MOD2 values that this divider comprises.

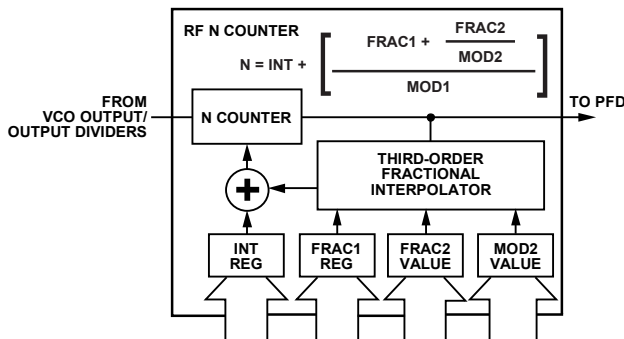

Figure 21. RF N Divider

### INT, FRACx, MODx, and R Counter Relationship

The INT, FRAC1, FRAC2, MOD1, and MOD2 values, in conjunction with the R counter, make it possible to generate output frequencies spaced by fractions of the PFD frequency ( $f_{PFD}$ ). For more information, see the RF Synthesizer—A Worked Example section.

Calculate the RF VCO frequency ( $VCO_{OUT}$ ) by

$$VCO_{OUT} = f_{PFD} \times N \quad (1)$$

where:

$VCO_{OUT}$  is the output frequency of the VCO (without using the output divider).

$f_{PFD}$  is the frequency of the phase frequency detector.

$N$  is the desired value of the feedback counter,  $N$ .

Calculate  $f_{PFD}$  by

$$f_{PFD} = REF_{IN} \times ((1 + D)/(R \times (1 + T))) \quad (2)$$

where:

$REF_{IN}$  is the reference input frequency.

$D$  is the  $REF_{IN}$  doubler bit.

$R$  is the preset divide ratio of the binary 10-bit programmable reference counter (1 to 1023).

$T$  is the  $REF_{IN}$  divide by 2 bit (0 or 1).

$N$  comprises

$$N = INT + \frac{FRAC1 + \frac{FRAC2}{MOD2}}{MOD1} \quad (3)$$

where:

$INT$  is the 16-bit integer value (23 to 32,767 for the 4/5 prescaler, and 75 to 65,535 for the 8/9 prescaler).

$FRAC1$  is the numerator of the primary modulus (0 to 16,777,215).

$FRAC2$  is the numerator of the 28-bit auxiliary modulus (0 to 268,435,455).

$MOD2$  is the programmable, 28-bit auxiliary fractional modulus (2 to 268,435,455).

$MOD1$  is a 24-bit primary modulus with a fixed value of  $2^{24} = 16,777,216$ .

Equation 3 results in a very fine frequency resolution with no residual frequency error. To apply this formula, take the following steps:

1. Calculate  $N$  by dividing  $VCO_{OUT}/f_{PFD}$ .
2. The integer value of this number forms  $INT$ .
3. Subtract the  $INT$  value from the full  $N$  value.
4. Multiply the remainder by  $2^{24}$ .
5. The integer value of this number forms  $FRAC1$ .
6. Calculate  $MOD2$  based on the channel spacing ( $f_{CHSP}$ ) by

$$MOD2 = f_{PFD}/GCD(f_{PFD}, f_{CHSP}) \quad (4)$$

where:

$GCD(f_{PFD}, f_{CHSP})$  is the greatest common divider of the PFD frequency and the channel spacing frequency.

$f_{CHSP}$  is the desired channel spacing frequency.

7. Calculate  $FRAC2$  by the following equation:

$$FRAC2 = ((N - INT) \times 2^{24} - FRAC1) \times MOD2 \quad (5)$$

The FRAC2 and MOD2 fraction results in outputs with zero frequency error for channel spacings when

$$f_{PFD}/GCD(f_{PFD}/f_{CHSP}) < 268,435,455 \tag{6}$$

where:

$f_{PFD}$  is the frequency of the phase frequency detector.

GCD is a greatest common denominator function.

$f_{CHSP}$  is the desired channel spacing frequency.

If zero frequency error is not required, the MOD1 and MOD2 denominators operate together to create a 52-bit resolution modulus.

**INT N Mode**

When FRAC1 and FRAC2 are 0, the synthesizer operates in integer-N mode.

**R Counter**

The 10-bit R counter allows the input reference frequency ( $REF_{IN}$ ) to be divided down to produce the reference clock to the PFD. Division ratios from 1 to 1023 are allowed.

**PHASE FREQUENCY DETECTOR (PFD) AND CHARGE PUMP**

The PFD takes inputs from the R counter and N counter and produces an output proportional to the phase and frequency difference between them. Figure 22 is a simplified schematic of the phase frequency detector. The PFD includes a fixed delay element that sets the width of the antbacklash pulse. This pulse ensures that there is no dead zone in the PFD transfer function and provides a consistent reference spur level. Set the phase detector polarity to positive on this device because of the positive tuning of the VCO.

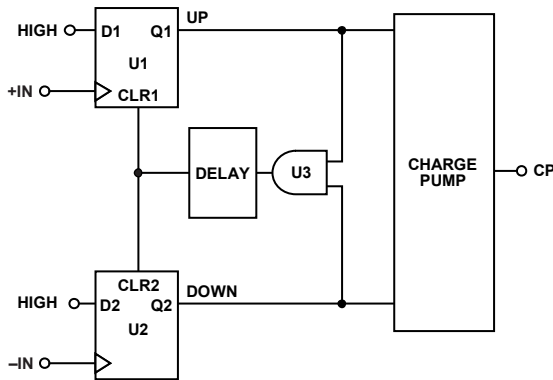

Figure 22. PFD Simplified Schematic

15084-022

**MUXOUT AND LOCK DETECT**

The output multiplexer on the ADF4356 allows the user to access various internal points on the chip. The M3, M2, and M1 bits in Register 4 control the state of MUXOUT. Figure 23 shows the MUXOUT section in block diagram form.

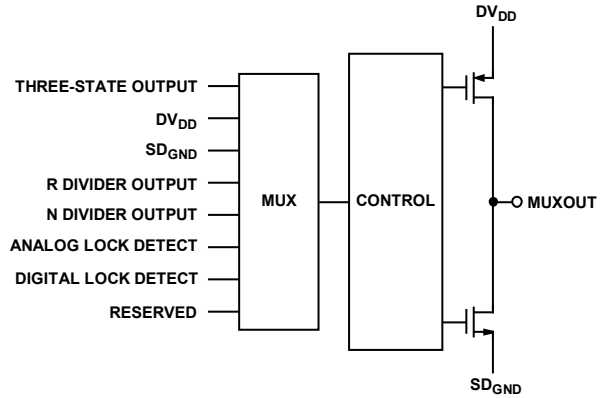

Figure 23. MUXOUT Schematic

15084-023

**INPUT SHIFT REGISTERS**

The ADF4356 digital section includes a 10-bit R counter, a 16-bit RF integer-N counter, a 24-bit FRAC1 counter, a 28-bit auxiliary fractional counter, and a 28-bit auxiliary modulus counter. Data clocks into the 32-bit shift register on each rising edge of CLK. The data clocks in MSB first. Data transfers from the shift register to one of 13 latches on the rising edge of LE. The state of the four control bits (C4, C3, C2, and C1) in the shift register determines the destination latch. As shown in Figure 2, the four least significant bits (LSBs) are DB3, DB2, DB1, and DB0. The truth table for these bits is shown in Table 6. Figure 26 and Figure 27 summarize the programming of the latches.

Table 6. Truth Table for the C4, C3, C2, and C1 Control Bits

Control Bits				Register
C4	C3	C2	C1	
0	0	0	0	Register 0
0	0	0	1	Register 1
0	0	1	0	Register 2
0	0	1	1	Register 3
0	1	0	0	Register 4
0	1	0	1	Register 5
0	1	1	0	Register 6
0	1	1	1	Register 7
1	0	0	0	Register 8
1	0	0	1	Register 9
1	0	1	0	Register 10
1	0	1	1	Register 11
1	1	0	0	Register 12
1	1	0	1	Register 13

**PROGRAM MODES**

Table 6 and Figure 28 through Figure 41 show how the program modes must be set up for the ADF4356.

The following settings in the ADF4356 are double-buffered: main fractional value (FRAC1), auxiliary modulus value (MOD2), auxiliary fractional value (FRAC2), reference doubler, reference divide by 2 (RDIV2), R counter value, and charge pump current setting. Two events must occur before the ADF4356 uses a new value for any of the double-buffered settings. First, the new value must latch into the device by writing to the appropriate register, and second, a new write to Register 0 must be performed.

For example, to ensure that the modulus value loads correctly, every time that the modulus value updates, Register 0 must be written to. The RF divider select in Register 6 is also double buffered, but only if DB14 of Register 4 is high.

**VCO**

The VCO core in the ADF4356 consists of four separate VCOs, each of which uses 256 overlapping bands, which allows the device to cover a wide frequency range without large VCO sensitivity ( $K_V$ ) and without resulting poor phase noise and spurious performance.

The correct VCO and band are chosen automatically by the VCO and band select logic when Register 0 is updated and auto-calibration is enabled.

The R counter output is used as the clock for the band select logic. After band selection, normal PLL action resumes. The nominal value of  $K_V$  is 25 MHz/V when the N divider is driven from the VCO output, or the  $K_V$  value is divided by D. D is the output divider value if the N divider is driven from the RF output divider (chosen by programming Bits[DB23:DB21] in Register 6).

The VCO shows variation of  $K_V$  as the tuning voltage,  $V_{TUNE}$ , varies within the band and from band to band. For wideband applications covering a wide frequency range (and changing output dividers), a value of 25 MHz/V provides the most accurate  $K_V$ , because this value is closest to the average value. Figure 24 shows how  $K_V$  varies with fundamental VCO frequency along with an average value for the frequency band. Users may prefer this figure when using narrow-band designs.

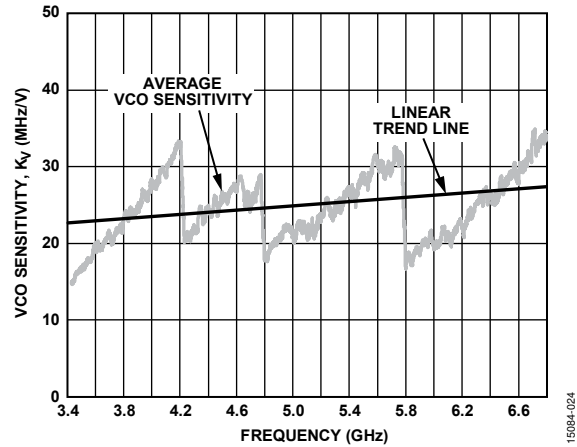

Figure 24. VCO Sensitivity,  $K_V$  vs. Frequency

**OUTPUT STAGE**

The RF<sub>OUTA+</sub> and RF<sub>OUTA-</sub> pins of the ADF4356 connect to the collectors of an NPN differential pair driven by buffered outputs of the VCO, as shown in Figure 25. In this scheme, the ADF4356 contains internal 50 Ω resistors connected to the V<sub>RF</sub> pin. To optimize the power dissipation vs. the output power requirements, the tail current of the differential pair is programmable using Bits[DB2:DB1] in Register 6. Four current levels can be set. These levels give approximate output power levels of -4 dBm, -1 dBm, +2 dBm, and +5 dBm, respectively. Levels of -4 dBm, -1 dBm, and +2 dBm can be achieved using a 50 Ω resistor to V<sub>RF</sub> and ac coupling into a 50 Ω load. For accurate power levels, refer to the Typical Performance Characteristics section. An output power of 5 dBm requires an external shunt inductor to provide higher power levels; however, this addition results in less wideband performance using the internal bias only. Terminate the unused complementary output with a similar circuit to the used output.

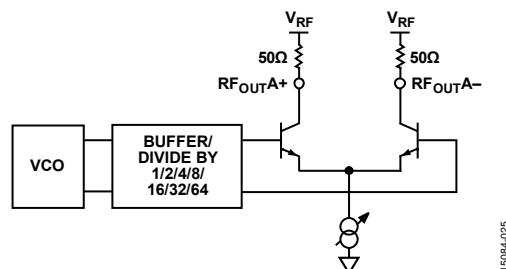

Figure 25. Output Stage

Another feature of the ADF4356 is that the supply current to the RF<sub>OUTA+</sub>/RF<sub>OUTA-</sub> output stage can shut down until the ADF4356 achieves lock as measured by the digital lock detect circuitry. The mute till lock detect (MTLD) bit (Bit DB11) in Register 6 enables this function.

The RF<sub>OUTB+</sub>/RF<sub>OUTB-</sub> pins are duplicate outputs that can be used independently or in addition to the RF<sub>OUTA+</sub>/RF<sub>OUTA-</sub> pins.



Table 7. Total I<sub>DD</sub> (RF Output A Enabled/RF Output B Disabled)<sup>1</sup>

Divide By	RF <sub>OUTA±</sub> Off	RF <sub>OUTA±</sub> = -4 dBm	RF <sub>OUTA±</sub> = -1 dBm	RF <sub>OUTA±</sub> = 2 dBm	RF <sub>OUTA±</sub> = 5 dBm
5 V Supply (I <sub>VCO</sub> and I <sub>P</sub> )	78 mA	78 mA	78 mA	78 mA	78 mA
3.3 V Supply (A <sub>I<sub>DD</sub></sub> , D <sub>I<sub>DD</sub></sub> , and I <sub>RF</sub> )					
1	84.8	106.2	117.3	128.2	138.9
2	94.1	114.9	125.7	136.4	146.5
4	103.9	124.9	136.2	147.3	158.0
8	111.9	132.9	144.3	155.6	166.8
16	116.9	138.0	149.5	160.7	171.8
32	120.9	142.0	153.6	164.8	176.1
64	123.3	144.4	156.0	167.3	178.4

<sup>1</sup> RF<sub>OUTA±</sub> refers to RF<sub>OUTA+</sub>/RF<sub>OUTA-</sub>.Table 8. Total I<sub>DD</sub> (RF Output A Enabled/RF Output B Enabled)<sup>1</sup>

Divide By	RF <sub>OUTA±</sub> /RF <sub>OUTB±</sub> Off	RF <sub>OUTA±</sub> /RF <sub>OUTB±</sub> = -4 dBm	RF <sub>OUTA±</sub> /RF <sub>OUTB±</sub> = -1 dBm	RF <sub>OUTA±</sub> /RF <sub>OUTB±</sub> = 2 dBm	RF <sub>OUTA±</sub> /RF <sub>OUTB±</sub> = 5 dBm
5 V Supply (I <sub>VCO</sub> and I <sub>P</sub> )	78 mA	78 mA	78 mA	78 mA	78 mA
3.3 V Supply (A <sub>I<sub>DD</sub></sub> , D <sub>I<sub>DD</sub></sub> , and I <sub>RF</sub> )					
1	84.9	133.5	150.0	166.3	182.1
2	94.2	142.4	159.8	177.2	193.6
4	104.0	151.9	169.5	187.0	204.0
8	112.0	159.7	177.3	194.7	211.6
16	117.0	164.5	182.2	199.5	216.5
32	121.0	168.4	186.1	203.5	220.4
64	123.4	170.8	188.6	205.8	222.8

<sup>1</sup> RF<sub>OUTA±</sub> refers to RF<sub>OUTA+</sub>/RF<sub>OUTA-</sub> and RF<sub>OUTB±</sub> refers to RF<sub>OUTB+</sub>/RF<sub>OUTB-</sub>.

REGISTER MAPS

REGISTER 0

RESERVED											AUTOCAL	PRESCALER	16-BIT INTEGER VALUE (INT)														CONTROL BITS					
DB31	DB30	DB29	DB28	DB27	DB26	DB25	DB24	DB23	DB22	DB21	DB20	DB19	DB18	DB17	DB16	DB15	DB14	DB13	DB12	DB11	DB10	DB9	DB8	DB7	DB6	DB5	DB4	DB3	DB2	DB1	DB0	
0	0	0	0	0	0	0	0	0	0	0	AC1	PR1	N16	N15	N14	N13	N12	N11	N10	N9	N8	N7	N6	N5	N4	N3	N2	N1	C4(0)	C3(0)	C2(0)	C1(0)

REGISTER 1

RESERVED				24-BIT MAIN FRACTIONAL VALUE (FRAC1)																DBR <sup>1</sup>				CONTROL BITS							
DB31	DB30	DB29	DB28	DB27	DB26	DB25	DB24	DB23	DB22	DB21	DB20	DB19	DB18	DB17	DB16	DB15	DB14	DB13	DB12	DB11	DB10	DB9	DB8	DB7	DB6	DB5	DB4	DB3	DB2	DB1	DB0
0	0	0	0	F24	F23	F22	F21	F20	F19	F18	F17	F16	F15	F14	F13	F12	F11	F10	F9	F8	F7	F6	F5	F4	F3	F2	F1	C4(0)	C3(0)	C2(0)	C1(1)

REGISTER 2

14-BIT AUXILIARY FRACTIONAL LSB VALUE (FRAC2_LSB)														14-BIT AUXILIARY MODULUS MSB VALUE (MOD2_LSB)														CONTROL BITS			
DB31	DB30	DB29	DB28	DB27	DB26	DB25	DB24	DB23	DB22	DB21	DB20	DB19	DB18	DB17	DB16	DB15	DB14	DB13	DB12	DB11	DB10	DB9	DB8	DB7	DB6	DB5	DB4	DB3	DB2	DB1	DB0
F14	F13	F12	F11	F10	F9	F8	F7	F6	F5	F4	F3	F2	F1	M14	M13	M12	M11	M10	M9	M8	M7	M6	M5	M4	M3	M2	M1	C4(0)	C3(0)	C2(1)	C1(0)

REGISTER 3

RESERVED	SD LOAD RESET	PHASE RESYNC	PHASE ADJUST	24-BIT PHASE VALUE (PHASE)																DBR <sup>1</sup>				CONTROL BITS							
DB31	DB30	DB29	DB28	DB27	DB26	DB25	DB24	DB23	DB22	DB21	DB20	DB19	DB18	DB17	DB16	DB15	DB14	DB13	DB12	DB11	DB10	DB9	DB8	DB7	DB6	DB5	DB4	DB3	DB2	DB1	DB0
0	SD1	PR1	PA1	P24	P23	P22	P21	P20	P19	P18	P17	P16	P15	P14	P13	P12	P11	P10	P9	P8	P7	P6	P5	P4	P3	P2	P1	C4(0)	C3(0)	C2(1)	C1(1)

REGISTER 4

RESERVED	MUXOUT			REFERENCE DOUBLER DBR <sup>1</sup>	RDIV2	DBR <sup>1</sup>	10-BIT R COUNTER										DOUBLE BUFF	CURRENT SETTING	DBR <sup>1</sup>	REF MODE	MUX LOGIC	PD POLARITY	POWER-DOWN	CP THREE-STATE	COUNTER RESET	CONTROL BITS					
DB31	DB30	DB29	DB28	DB27	DB26	DB25	DB24	DB23	DB22	DB21	DB20	DB19	DB18	DB17	DB16	DB15	DB14	DB13	DB12	DB11	DB10	DB9	DB8	DB7	DB6	DB5	DB4	DB3	DB2	DB1	DB0
0	0	M3	M2	M1	RD2	RD1	R10	R9	R8	R7	R6	R5	R4	R3	R2	R1	D1	CP4	CP3	CP2	CP1	U6	U5	U4	U3	U2	U1	C4(0)	C3(1)	C2(0)	C1(0)

REGISTER 5

RESERVED																												CONTROL BITS				
DB31	DB30	DB29	DB28	DB27	DB26	DB25	DB24	DB23	DB22	DB21	DB20	DB19	DB18	DB17	DB16	DB15	DB14	DB13	DB12	DB11	DB10	DB9	DB8	DB7	DB6	DB5	DB4	DB3	DB2	DB1	DB0	
0	0	0	0	0	0	0	0	1	0	0	0	0	0	0	0	0	0	0	0	0	0	0	0	0	0	0	1	0	C4(0)	C3(1)	C2(0)	C1(1)

REGISTER 6

BLEED POLARITY	GATED BLEED	NEGATIVE BLEED	RESERVED			RF OUTPUT B SELECT	FEEDBACK SELECT	RF DIVIDER SELECT <sup>2</sup>	CHARGE PUMP BLEED CURRENT										RESERVED	MTLD	RESERVED	RF OUTPUT B ENABLE	RF OUTPUT B POWER	RF OUTPUT A ENABLE	RF OUTPUT A POWER	CONTROL BITS					
DB31	DB30	DB29	DB28	DB27	DB26	DB25	DB24	DB23	DB22	DB21	DB20	DB19	DB18	DB17	DB16	DB15	DB14	DB13	DB12	DB11	DB10	DB9	DB8	DB7	DB6	DB5	DB4	DB3	DB2	DB1	DB0
BP1	BL10	BL9	1	0	1	D14	D13	D12	D11	D10	BL8	BL7	BL6	BL5	BL4	BL3	BL2	BL1	0	D8	0	D6	D5	D4	D3	D2	D1	C4(0)	C3(1)	C2(1)	C1(0)

<sup>1</sup>DBR = DOUBLE BUFFERED REGISTER—BUFFERED BY THE WRITE TO REGISTER 0.  
<sup>2</sup>DBB = DOUBLE BUFFERED BITS—BUFFERED BY A WRITE TO REGISTER 0 WHEN BIT DB14 OF REGISTER 4 IS HIGH.

Figure 26.

15084-026

REGISTER 7

RESERVED																LE SEL SYNC EDGE	RESERVED	LE SYNC	RESERVED																LD CYCLE COUNT		LOL MODE	FRAC-N LD PRECISION		LD MODE	CONTROL BITS			
DB31	DB30	DB29	DB28	DB27	DB26	DB25	DB24	DB23	DB22	DB21	DB20	DB19	DB18	DB17	DB16	DB15	DB14	DB13	DB12	DB11	DB10	DB9	DB8	DB7	DB6	DB5	DB4	DB3	DB2	DB1	DB0													
0	0	0	0	LE2	1	LE1	0	0	0	0	0	0	0	0	0	0	0	0	0	0	0	LD5	LD4	LOL	LD3	LD2	LD1	C4(0)	C3(1)	C2(1)	C1(1)													

REGISTER 8

RESERVED																																CONTROL BITS			
DB31	DB30	DB29	DB28	DB27	DB26	DB25	DB24	DB23	DB22	DB21	DB20	DB19	DB18	DB17	DB16	DB15	DB14	DB13	DB12	DB11	DB10	DB9	DB8	DB7	DB6	DB5	DB4	DB3	DB2	DB1	DB0				
0	0	0	1	0	1	0	1	0	1	0	1	1	0	0	1	0	1	1	0	0	1	0	1	0	1	1	0	C4(1)	C3(0)	C2(0)	C1(0)				

REGISTER 9

VCO BAND DIVISION								TIMEOUT								AUTOMATIC LEVEL CALIBRATION TIMEOUT				SYNTHESIZER LOCK TIMEOUT				CONTROL BITS							
DB31	DB30	DB29	DB28	DB27	DB26	DB25	DB24	DB23	DB22	DB21	DB20	DB19	DB18	DB17	DB16	DB15	DB14	DB13	DB12	DB11	DB10	DB9	DB8	DB7	DB6	DB5	DB4	DB3	DB2	DB1	DB0
VC8	VC7	VC6	VC5	VC4	VC3	VC2	VC1	TL10	TL9	TL8	TL7	TL6	TL5	TL4	TL3	TL2	TL1	AL5	AL4	AL3	AL2	AL1	SL5	SL4	SL3	SL2	SL1	C4(1)	C3(0)	C2(0)	C1(1)

REGISTER 10

RESERVED																ADC CLOCK DIVIDER										ADC CONVERSION	ADC ENABLE	CONTROL BITS			
DB31	DB30	DB29	DB28	DB27	DB26	DB25	DB24	DB23	DB22	DB21	DB20	DB19	DB18	DB17	DB16	DB15	DB14	DB13	DB12	DB11	DB10	DB9	DB8	DB7	DB6	DB5	DB4	DB3	DB2	DB1	DB0
0	0	0	0	0	0	0	0	1	1	0	0	0	0	0	0	0	0	AD8	AD7	AD6	AD5	AD4	AD3	AD2	AD1	AE2	AE1	C4(1)	C3(0)	C2(1)	C1(0)

REGISTER 11

RESERVED								VCO BAND HOLD	RESERVED																CONTROL BITS						
DB31	DB30	DB29	DB28	DB27	DB26	DB25	DB24	DB23	DB22	DB21	DB20	DB19	DB18	DB17	DB16	DB15	DB14	DB13	DB12	DB11	DB10	DB9	DB8	DB7	DB6	DB5	DB4	DB3	DB2	DB1	DB0
0	0	0	0	0	0	0	VH	0	1	1	0	0	0	0	1	0	0	1	0	0	0	0	0	0	0	0	0	C4(1)	C3(0)	C2(1)	C1(1)

REGISTER 12

PHASE RESYNC CLOCK VALUE																RESERVED																CONTROL BITS			
DB31	DB30	DB29	DB28	DB27	DB26	DB25	DB24	DB23	DB22	DB21	DB20	DB19	DB18	DB17	DB16	DB15	DB14	DB13	DB12	DB11	DB10	DB9	DB8	DB7	DB6	DB5	DB4	DB3	DB2	DB1	DB0				
P20	P19	P18	P17	P16	P15	P14	P13	P12	P11	P10	P9	P8	P7	P6	P5	P4	P3	P2	P1	0	0	0	0	0	0	0	1	C4(1)	C3(1)	C2(0)	C1(0)				

REGISTER 13

14-BIT AUXILIARY FRACTIONAL MSB VALUE (FRAC2_MSB) DBR <sup>1</sup>														14-BIT AUXILIARY MODULUS MSB VALUE (MOD2_MSB) DBR <sup>1</sup>														CONTROL BITS			
DB31	DB30	DB29	DB28	DB27	DB26	DB25	DB24	DB23	DB22	DB21	DB20	DB19	DB18	DB17	DB16	DB15	DB14	DB13	DB12	DB11	DB10	DB9	DB8	DB7	DB6	DB5	DB4	DB3	DB2	DB1	DB0
F14	F13	F12	F11	F10	F9	F8	F7	F6	F5	F4	F3	F2	F1	M14	M13	M12	M11	M10	M9	M8	M7	M6	M5	M4	M3	M2	M1	C4(1)	C3(1)	C2(0)	C1(1)

Figure 27. Register Summary (Register 7 to Register 13)

15884-027

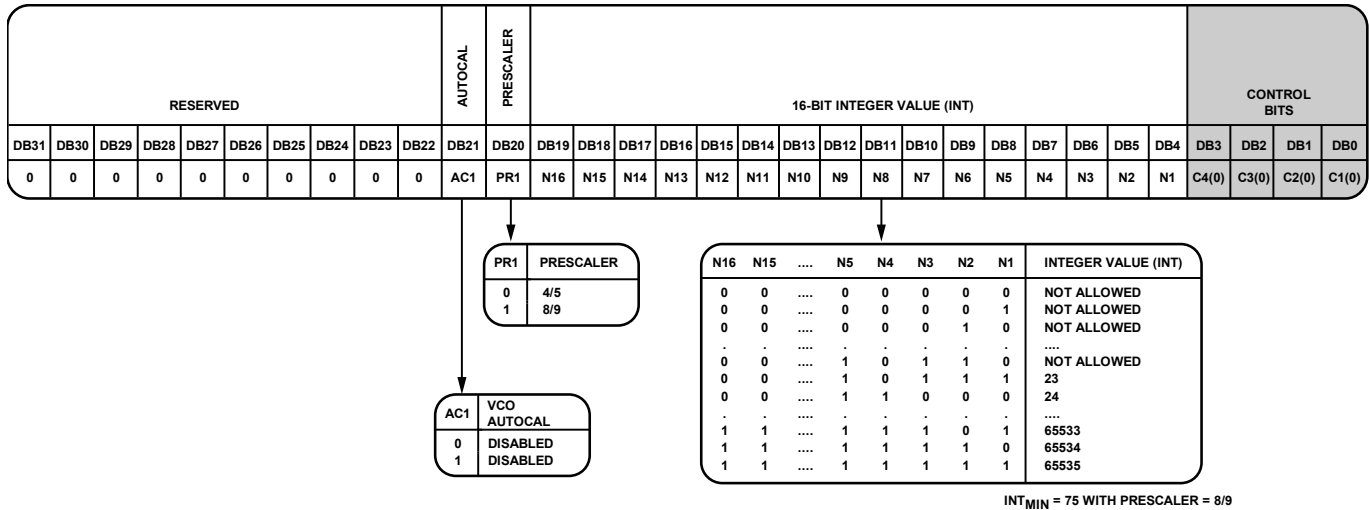

Figure 28. Register 0

**REGISTER 0**

**Control Bits**

With Bits[C4:C1] set to 0000, Register 0 is programmed. Figure 28 shows the input data format for programming this register.

**Reserved**

Bits[DB31:DB22] are reserved and must be set to 0.

**Automatic Calibration (AUTOCAL)**

Write to Register 0 to enact (by default) the VCO automatic calibration, and to choose the appropriate VCO and VCO subband. Write 1 to the AC1 bit (Bit DB21) to enable the automatic calibration, which is the recommended mode of operation.

Set the AC1 bit (Bit DB21) to 0 to disable the automatic calibration, which leaves the ADF4356 in the same band it was already in when Register 0 is updated.

Disable the automatic calibration only for fixed frequency applications, phase adjust applications, or very small (<10 kHz) frequency jumps.

Toggling AUTOCAL is also required when changing frequency. See the Frequency Update Sequence section for more information.

**Prescaler Value**

The dual modulus prescaler (P/P + 1), along with the INT, FRACx, and MODx counters, determines the overall division ratio from the VCO output to the PFD input. The PR1 bit (Bit DB20) in Register 0 sets the prescaler value.

Operating at CML levels, the prescaler takes the clock from the VCO output and divides it down for the counters. It is based on a synchronous 4/5 core. When the prescaler is set to 4/5, the maximum RF frequency allowed is 7 GHz. The prescaler limits the INT value; therefore, if P is 4/5, N<sub>MIN</sub> is 23, and if P is 8/9, N<sub>MIN</sub> is 75.

**16-Bit Integer Value**

The 16 INT bits (Bits[DB19:DB4]) set the INT value, which determines the integer part of the feedback division factor. The INT value is used in Equation 3 (see the INT, FRACx, MODx, and R Counter Relationship section). All integer values from 23 to 32,767 are allowed for the 4/5 prescaler. For the 8/9 prescaler, the minimum integer value is 75, and the maximum value is 65,535.

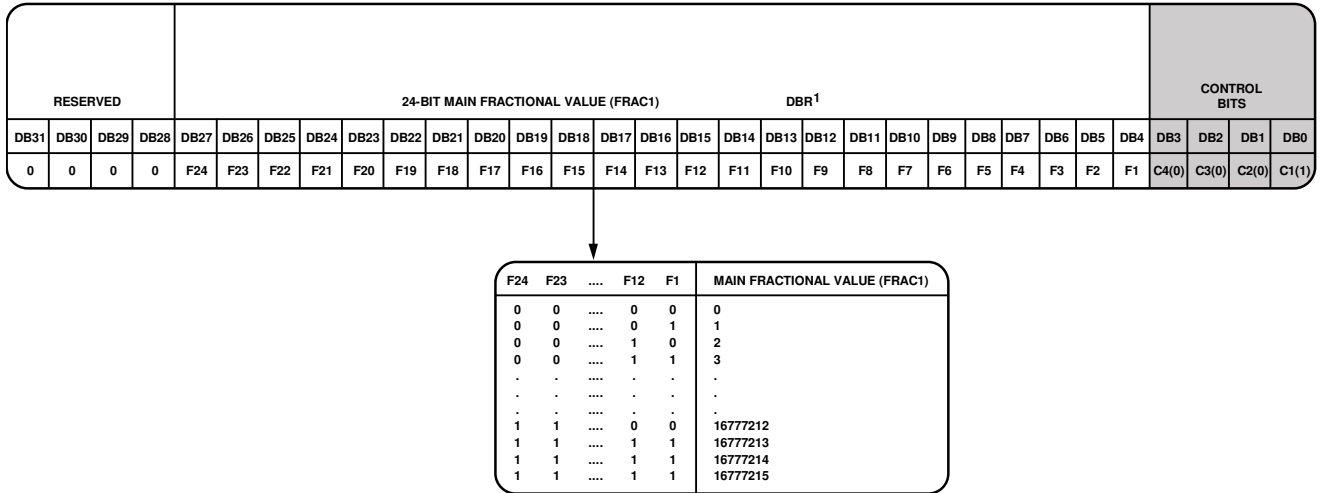

¹DBR = DOUBLE BUFFERED REGISTER—BUFFERED BY THE WRITE TO REGISTER 0.

Figure 29. Register 1

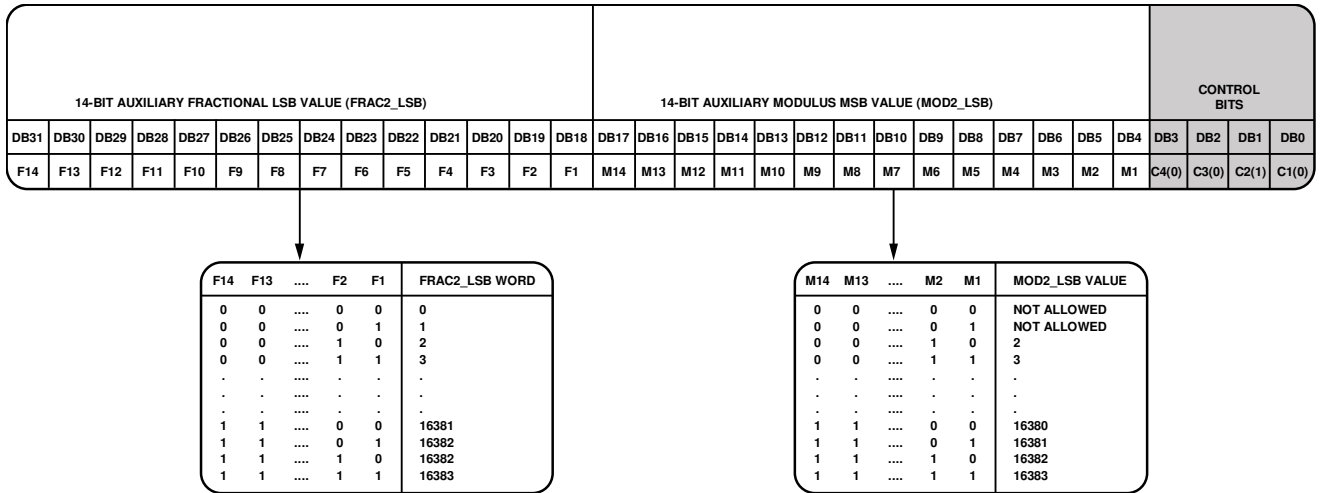

¹DBR = DOUBLE BUFFERED REGISTER—BUFFERED BY THE WRITE TO REGISTER 0.

Figure 30. Register 2

**REGISTER 1**

**Control Bits**

With Bits[C4:C1] set to 0001, Register 1 is programmed. Figure 29 shows the input data format for programming this register.

**Reserved**

Bits[DB31:DB28] are reserved and must be set to 0.

**24-Bit Main Fractional Value**

The 24 FRAC1 bits (Bits[DB27:DB4]) set the numerator of the fraction that is input to the Σ-Δ modulator. This fraction, along with the INT value, specifies the new frequency channel that the synthesizer locks to, as shown in the RF Synthesizer—A Worked Example section. FRAC1 values from 0 to (MOD1 – 1) cover channels over a frequency range equal to the PFD reference frequency.

**REGISTER 2**

**Control Bits**

With Bits[C4:C1] set to 0010, Register 2 is programmed. Figure 30 shows the input data format for programming this register.

**14-Bit Auxiliary Fractional LSB Value (FRAC2\_LSB)**

Use this value with the auxiliary fractional MSB value (Register 13, Bits[DB31:DB18]) to generate the total auxiliary fractional value.

$$FRAC2 = (FRAC2\_MSB \times 2^{14}) + FRAC2\_LSB$$

FRAC2 must be less than the MOD2 value programmed in Register 2.

**14-Bit Auxiliary Modulus LSB Value (MOD2\_LSB)**

Use this value with the auxiliary modulus MSB value (Register 13, Bits[DB17:DB4]) to generate total auxiliary modulus value.

$$MOD2 = (MOD2\_MSB) \times 2^{14} + MOD2\_LSB$$

Use MOD2 to correct any residual error due to the main fractional modulus.

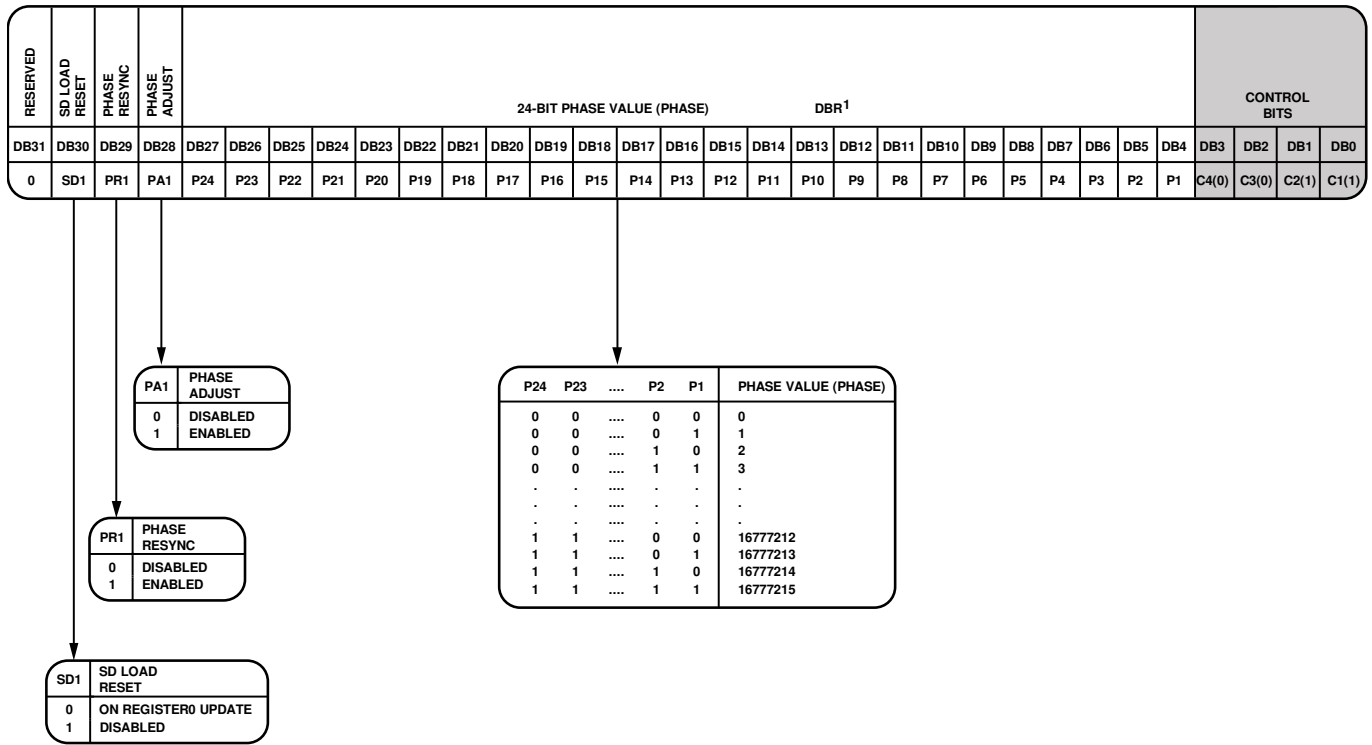

<sup>1</sup>DBR = DOUBLE BUFFERED REGISTER—BUFFERED BY THE WRITE TO REGISTER 0.

Figure 31. Register 3

**REGISTER 3**

**Control Bits**

With Bits[C4:C1] set to 0011, Register 3 is programmed. Figure 31 shows the input data format for programming this register.

**Reserved**

Bit DB31 is reserved and must be set to 0.

**SD Load Reset**

When writing to Register 0, the Σ-Δ modulator resets. For applications in which the phase is continually adjusted, this may not be desirable; therefore, in these cases, the Σ-Δ reset can be disabled by writing a 1 to the SD1 bit (Bit DB30).

**Phase Resync**

To use the phase resynchronization feature, the PR1 bit (Bit DB29) must be set to 1. If unused, the bit can be programmed to 0. The phase resync activation timeout value must also be used in Register 12 to ensure that the resynchronization feature is applied after the PLL settles to the final frequency. If the PLL has not settled to the final frequency, phase resync may not function correctly. Resynchronization is useful in phased array and beam forming applications. It ensures repeatability of output phase when programming the same frequency. In phase critical applications that use frequencies requiring the output divider (<3400 MHz), it is necessary to feed the N divider with the divided VCO frequency as distinct from the fundamental VCO frequency, which is achieved by programming the D13 bit (Bit DB24) in Register 6 to 0, which ensures divided feedback to the N divider.

For resync applications, enable the Σ-Δ modulator load reset (SD load reset) in Register 3 by setting DB30 to 0.

The phase of the RF output frequency can be adjusted in 24-bit steps from 0° (0) to 360° (2<sup>24</sup> - 1) relative to the resync phase. For phase adjustment applications, the phase is set by Bits[P24:P1].

$$(Phase\ Value/16,777,216) \times 360^\circ$$

Practically, this means that repeatable adjustable phase values can be achieved by using the resync feature with different phase values.

**Phase Adjustment**

To adjust the relative output phase of the ADF4356 on each Register 0 update, set the PA1 bit (Bit DB28) to 1. This feature differs from the resynchronization feature in that it is useful when adjustments to phase are made continually in an application. For this function, disable the VCO automatic calibration by setting the AC1 bit (Bit DB21) in Register 0 to 1, and disable the SD load reset by setting the SD1 bit (Bit DB30) in Register 3 to 1.

**24-Bit Phase Value**

The phase of the RF output frequency can adjust in 24-bit steps, from 0° (0) to 360° (2<sup>24</sup> - 1). For phase adjust applications, the phase is set by

$$(Phase\ Value/16,777,216) \times 360^\circ$$

When the phase value is programmed to Register 3, each subsequent adjustment of Register 0 increments the phase by the value in this equation.

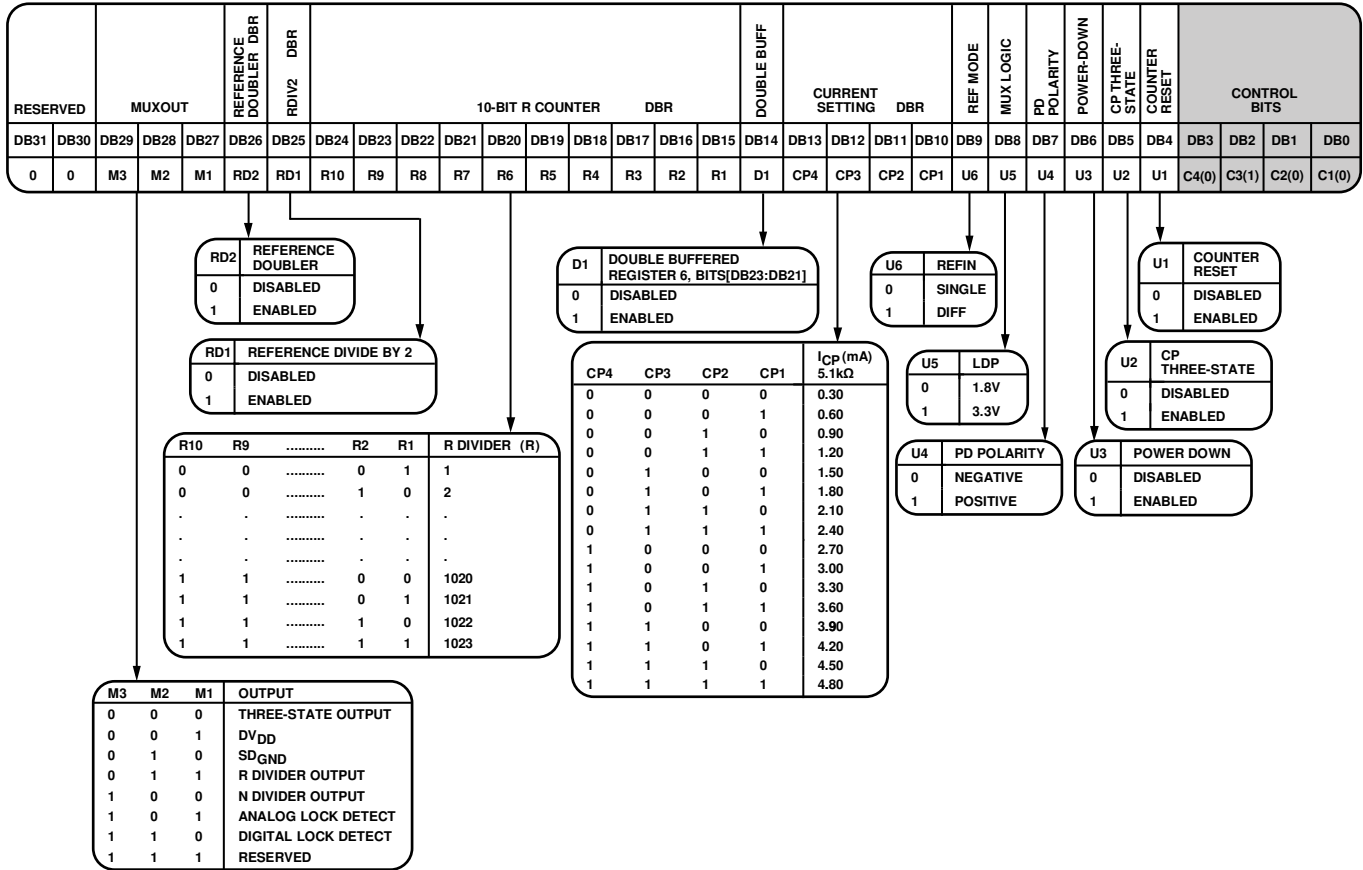

<sup>1</sup>DBR = DOUBLE BUFFERED REGISTER—BUFFERED BY THE WRITE TO REGISTER 0.

Figure 32. Register 4

**REGISTER 4**

**Control Bits**

With Bits[C4:C1] set to 0100, Register 4 is programmed. Figure 32 shows the input data format for programming this register.

**Reserved**

Bits[DB31:DB30] are reserved and must be set to 0.

**MUXOUT**

The on-chip multiplexer (MUXOUT) is controlled by Bits[DB29:DB27]. For additional details, see Figure 32.

When changing frequency, that is, writing Register 0, MUXOUT must not be set to N divider output or R divider output. If needed, enable these functions after locking to the new frequency.

**Reference Doubler**

Setting the RD2 bit (Bit DB26) to 0 feeds the reference frequency signal directly to the 10-bit R counter, disabling the doubler. Setting this bit to 1 multiplies the reference frequency by a factor of 2 before feeding it into the 10-bit R counter. When the doubler is disabled, the REF<sub>IN</sub> falling edge is the active edge at the PFD input to the fractional synthesizer. When the doubler is enabled, both the rising and falling edges of the reference frequency become active edges at the PFD input.

The maximum allowable reference frequency when the doubler is enabled is 80 MHz.

**RDIV2**

Setting the RDIV2 bit (Bit DB25) to 1 inserts a divide by 2, toggle flip-flop between the R counter and PFD, which extends the maximum reference frequency input rate. This function provides a 50% duty cycle signal at the PFD input.

**10-Bit R Counter**

The 10-bit R counter divides the input reference frequency (REF<sub>IN</sub>) to produce the reference clock to the PFD. Division ratios range from 1 to 1023.

**Double Buffer**

The D1 bit (Bit DB14) enables or disables double buffering of the RF divider select bits (Bits[DB23:DB21]) in Register 6. The Program Modes section explains how double buffering works.

**Charge Pump Current Setting**

The CP4 to CP1 bits (Bits[DB13:DB10]) set the charge pump current. Set this value to the charge pump current that the loop filter is designed with (see Figure 32). For the lowest spurs, the 0.9 mA setting is recommended.

**Reference Mode**

The ADF4356 permits use of either differential or single-ended reference sources.

For optimum integer boundary spur performance, it is recommended to use the single-ended setting for all references up to 250 MHz (even if using a differential reference signal). Use the differential setting for reference frequencies above 250 MHz.

**Level Select**

To assist with logic compatibility, MUXOUT is programmable to two logic levels. Set the U5 bit (Bit DB8) to 0 to select 1.8 V logic, and set it to 1 to select 3.3 V logic.

**Phase Detector Polarity**

The U4 bit (Bit DB7) sets the phase detector polarity. When a passive loop filter or a noninverting active loop filter is used, set DB7 to 1 (positive). If an active filter with an inverting characteristic is used, set this bit to 0 (negative).

**Power-Down**

The U3 bit (Bit DB6) sets the programmable power-down mode. Setting DB6 to 1 performs a power-down. Setting DB6 to 0 returns the synthesizer to normal operation. In software power-down mode, the ADF4356 retains all information in its registers. The register contents are only lost if the supply voltages are removed.

When power-down activates, the following events occur:

- The synthesizer counters are forced to their load state conditions.
- The VCO powers down.
- The charge pump is forced into three-state mode.
- The digital lock detect circuitry resets.
- The RF<sub>OUTA+</sub>/RF<sub>OUTA-</sub> and RF<sub>OUTB+</sub>/RF<sub>OUTB-</sub> output stages are disabled.
- The input registers remain active and capable of loading and latching data.

**Charge Pump Three-State**

Setting the U2 bit (Bit DB5) to 1 puts the charge pump into three-state mode. Set DB5 to 0 for normal operation.

**Counter Reset**

The U1 bit (Bit DB4) resets the R counter, N counter, and VCO band select of the ADF4356. When DB4 is set to 1, the RF synthesizer N counter, R counter, and VCO band select are reset. For normal operation, set DB4 to 0.

**REGISTER 5**

The bits in Register 5 are reserved and must be programmed as described in Figure 33, using a hexadecimal word of 0x00800025.

RESERVED																												CONTROL BITS				
DB31	DB30	DB29	DB28	DB27	DB26	DB25	DB24	DB23	DB22	DB21	DB20	DB19	DB18	DB17	DB16	DB15	DB14	DB13	DB12	DB11	DB10	DB9	DB8	DB7	DB6	DB5	DB4	DB3	DB2	DB1	DB0	
0	0	0	0	0	0	0	0	0	1	0	0	0	0	0	0	0	0	0	0	0	0	0	0	0	0	0	1	0	C4(0)	C3(1)	C2(0)	C1(1)

Figure 33. Register 5 (0x00800025)

15984-033



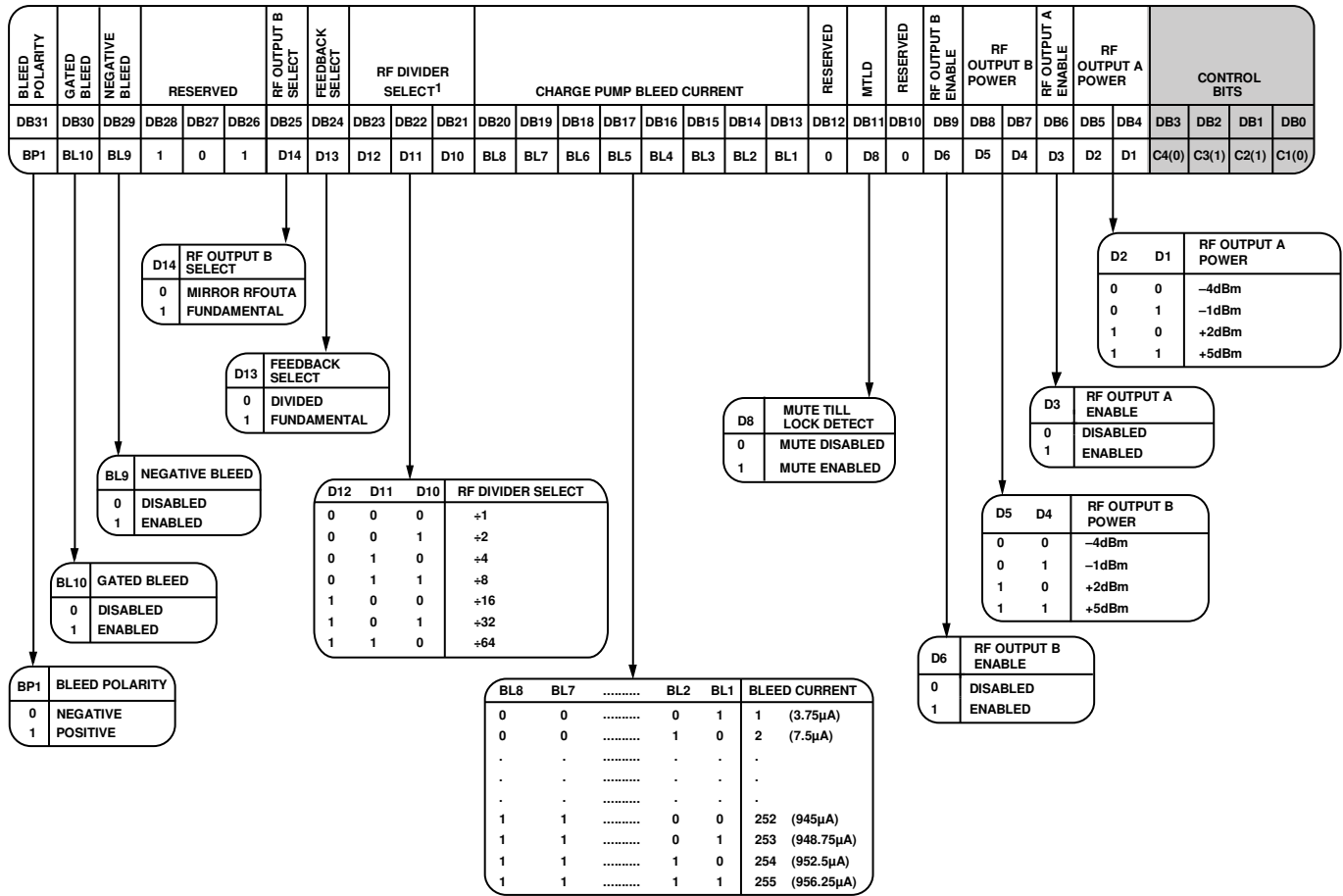

<sup>1</sup>BITS[DB23:DB21] ARE BUFFERED BY A WRITE TO REGISTER 0 WHEN THE DOUBLE BUFFER BIT, BIT DB14 OF REGISTER 4, IS ENABLED.

Figure 34. Register 6

**REGISTER 6**

**Control Bits**

With [C4:C1] set to 0110, Register 6 is programmed. Figure 34 shows the input data format for programming this register.

**Bleed Polarity**

DB31 sets the polarity of the charge pump bleed current.

**Gated Bleed**

Bleed currents can be used for improving phase noise and spurs; however, due to a potential impact on lock time, the gated bleed bit, BL10 (Bit DB30), if set to 1, ensures bleed currents are not switched on until the digital lock detect asserts logic high. Note that this function requires digital lock detect to be enabled.

**Negative Bleed**

Use of constant negative bleed is recommended for most fractional-N applications because it improves the linearity of the charge pump, leading to lower noise and spurious signals than leaving it off. To enable negative bleed, write 1 to BL9 (Bit DB29), and to disable negative bleed, write 0 to BL9 (Bit DB29).

Do not use negative bleed when operating in Integer-N mode, that is, FRAC1 = FRAC2 = 0. Do not use negative bleed for *f<sub>PEL</sub>* greater than 100 MHz.

**Reserved**

Bits[DB28:DB26] are reserved and must be set to 101. Bit DB12 is reserved and must be set to 0. Bit DB10 is reserved and must be set to 0.

**RF Output B Select**

D14 (Bit DB25) enables the RF output B (RF<sub>OUTB+</sub>/RF<sub>OUTB-</sub>) to selects the fundamental output from the VCO. When this bit is disabled, RF<sub>OUTB+</sub>/RF<sub>OUTB-</sub> is a duplicate of RF<sub>OUTA+</sub>/RF<sub>OUTA-</sub>.

**Feedback Select**

D13 (Bit DB24) selects the feedback from the output of the VCO to the N counter. When D13 is set to 1, the signal is taken directly from the VCO. When this bit is set to 0, the signal is taken from the output of the output dividers. The dividers enable coverage of the wide frequency band (54 MHz to 6800 MHz). When the divider is enabled and the feedback signal is taken from the output, the RF output signals of two separately configured PLLs are in phase. Divided feedback is useful in some applications where the positive interference of signals is required to increase the power.

**Divider Select**

D12 to D10 (Bits[DB23:DB21]) select the value of the RF output divider (see Figure 34).

**Charge Pump Bleed Current**

BL8 to BL1 (Bits[DB20:DB13]) control the level of the bleed current added to the charge pump output. This current optimizes the phase noise and spurious levels from the device.

Calculate the optimal bleed setting using the following rule.

$$\text{Bleed Value} = \text{floor}(24 \times (f_{\text{PFD}}/61.44 \text{ MHz}) \times (I_{\text{CP}}/0.9 \text{ mA}))$$

If  $f_{\text{PFD}} > 100 \text{ MHz}$ , disable bleed current using DB29.

where:

*Bleed Value* is the value programmed to Bits[DB20:DB13].

floor() is a function to round down to the nearest integer value.

$f_{\text{PFD}}$  is the PFD frequency.

$I_{\text{CP}}$  is the value of charge pump current setting, Bits[DB13:DB10] of Register 4.

**Mute Till Lock Detect**

When D8 (Bit DB11) is set to 1, the supply current to the RF output stage is shut down until the device achieves lock, as determined by the digital lock detect circuitry.

**RF Output B Enable**

D6 (Bit DB9) enables or disables RF Output B (RF<sub>OUTB+</sub>/RF<sub>OUTB-</sub>). If DB10 is set to 0, RF Output B is enabled. If DB10 is set to 1, the RF Output B is disabled.

**RF Output B Power**

D5 and D4 (Bits[DB8:DB7]) set the value of the RF Output B (RF<sub>OUTB+</sub>/RF<sub>OUTB-</sub>) power level (see Figure 34).

**RF Output A Enable**

D3 (Bit DB6) enables or disables RF Output A (RF<sub>OUTA+</sub>/RF<sub>OUTA-</sub>). If DB3 is set to 0, RF Output A is disabled. If DB6 is set to 1, RF Output A is enabled.

**RF Output A Power**

D2 and D1 (Bits[DB5:DB4]) set the value of the RF Output A (RF<sub>OUTA+</sub>/RF<sub>OUTA-</sub>) power level (see Figure 34).