



Chipsmall Limited consists of a professional team with an average of over 10 year of expertise in the distribution of electronic components. Based in Hongkong, we have already established firm and mutual-benefit business relationships with customers from,Europe,America and south Asia,supplying obsolete and hard-to-find components to meet their specific needs.

With the principle of "Quality Parts,Customers Priority,Honest Operation,and Considerate Service",our business mainly focus on the distribution of electronic components. Line cards we deal with include Microchip,ALPS,ROHM,Xilinx,Pulse,ON,Everlight and Freescale. Main products comprise IC,Modules,Potentiometer,IC Socket,Relay,Connector.Our parts cover such applications as commercial,industrial, and automotives areas.

We are looking forward to setting up business relationship with you and hope to provide you with the best service and solution. Let us make a better world for our industry!



Contact us

Tel: +86-755-8981 8866 Fax: +86-755-8427 6832

Email & Skype: info@chipsmall.com Web: www.chipsmall.com

Address: A1208, Overseas Decoration Building, #122 Zhenhua RD., Futian, Shenzhen, China



FEATURES

- 1 pF off capacitance
- 2.6 pF on capacitance
- <1 pC charge injection
- 33 V supply range
- 120 Ω on resistance
- Fully specified at ± 15 V, +12 V
- No V_L supply required
- 3 V logic-compatible inputs
- Rail-to-rail operation
- 16-lead TSSOP and 16-lead LFCSP
- Typical power consumption: <0.03 μ W

APPLICATIONS

- Automatic test equipment
- Data acquisition systems
- Battery-powered systems
- Sample-and-hold systems
- Audio signal routing
- Video signal routing
- Communication systems

GENERAL DESCRIPTION

The [ADG1211/ADG1212/ADG1213](#) are monolithic complementary metal-oxide semiconductor (CMOS) devices containing four independently selectable switches designed on an *i*CMOS[®] (industrial CMOS) process. *i*CMOS is a modular manufacturing process combining high voltage CMOS and bipolar technologies. It enables the development of a wide range of high performance analog ICs capable of 33 V operation in a footprint that no previous generation of high voltage devices has been able to achieve.

Unlike analog ICs using conventional CMOS processes, *i*CMOS components can tolerate high supply voltages while providing increased performance, dramatically lower power consumption, and reduced package size.

The ultralow capacitance and charge injection of these switches make them ideal solutions for data acquisition and sample-and-hold applications, where low glitch and fast settling are required. Fast switching speed coupled with high signal bandwidth make the devices suitable for video signal switching.

*i*CMOS construction ensures ultralow power dissipation, making the devices ideally suited for portable and battery-powered instruments.

FUNCTIONAL BLOCK DIAGRAM

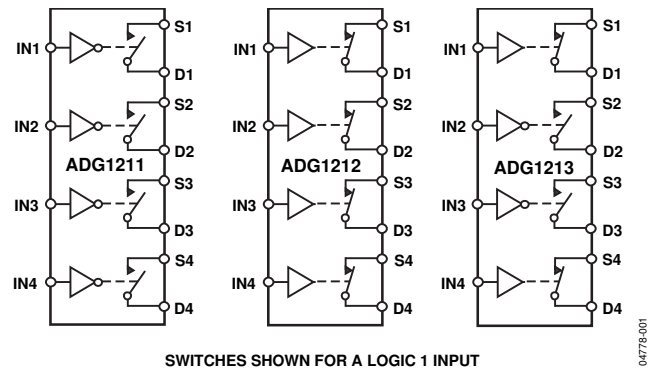

Figure 1.

The [ADG1211/ADG1212/ADG1213](#) contain four independent single-pole/single-throw (SPST) switches. The [ADG1211](#) and [ADG1212](#) differ only in that the digital control logic is inverted. The [ADG1211](#) switches are turned on with Logic 0 on the appropriate control input, while Logic 1 is required for the [ADG1212](#). The [ADG1213](#) has two switches with digital control logic similar to that of the [ADG1211](#); the logic is inverted on the other two switches. The [ADG1213](#) exhibits break-before-make switching action for use in multiplexer applications.

Each switch conducts equally well in both directions when on and has an input signal range that extends to the supplies. In the off condition, signal levels up to the supplies are blocked.

PRODUCT HIGHLIGHTS

1. Ultralow capacitance.
2. <1 pC charge injection.
3. 3 V logic-compatible digital inputs: $V_{IH} = 2.0$ V, $V_{IL} = 0.8$ V.
4. No V_L logic power supply required.
5. Ultralow power dissipation: <0.03 μ W.
6. 16-lead TSSOP and 3 mm \times 3 mm LFCSP packages.

TABLE OF CONTENTS

Features	1	Absolute Maximum Ratings	6
Applications.....	1	ESD Caution.....	6
Functional Block Diagram	1	Pin Configurations and Function Descriptions	7
General Description	1	Terminology	8
Product Highlights	1	Typical Performance Characteristics	9
Revision History	2	Test Circuits.....	12
Specifications.....	3	Outline Dimensions	14
Dual Supply	3	Ordering Guide	15
Single Supply	5		

REVISION HISTORY

11/2016—Rev. C to Rev. D		2/2009—Rev. 0 to Rev. A	
Change to VDD Parameter, Table 2	5	Changes to Power Requirements, I _{DD} , Digital Inputs = 5 V	
		Parameter, Table 1	4
3/2016—Rev. B to Rev. C		Changes to Power Requirements, I _{DD} , Digital Inputs = 5 V	
Changes to Figure 3.....	7	Parameter, Table 2	5
Updated Outline Dimensions	14		
Changes to Ordering Guide	15	7/2005—Revision 0: Initial Version	
8/2012—Rev. A to Rev. B			
Changes to Table 1.....	3		
Changes to Table 2.....	5		
Change to Table 6	7		
Updated Outline Dimensions	14		
Changes to Ordering Guide	15		

SPECIFICATIONS

DUAL SUPPLY

$V_{DD} = 15\text{ V} \pm 10\%$, $V_{SS} = -15\text{ V} \pm 10\%$, $GND = 0\text{ V}$, unless otherwise noted.

Table 1.

Parameter	Y Version ¹			Unit	Test Conditions/Comments
	25°C	-40°C to +85°C	-40°C to +125°C		
ANALOG SWITCH					
Analog Signal Range			V_{DD} to V_{SS}	V	
On Resistance (R_{ON})	120			Ω typ	$V_S = \pm 10\text{ V}$, $I_S = -1\text{ mA}$; see Figure 20
	190	230	260	Ω max	$V_{DD} = +13.5\text{ V}$, $V_{SS} = -13.5\text{ V}$
On Resistance Match Between Channels (ΔR_{ON})	2.5			Ω typ	$V_S = \pm 10\text{ V}$, $I_S = -1\text{ mA}$
On Resistance Flatness ($R_{FLAT(ON)}$)	6	10	11	Ω max	
	20			Ω typ	$V_S = -5\text{ V}/0\text{ V}/+5\text{ V}$; $I_S = -1\text{ mA}$
	57	72	79	Ω max	
LEAKAGE CURRENTS					
Source Off Leakage, I_S (Off)	± 0.02			nA typ	$V_{DD} = +16.5\text{ V}$, $V_{SS} = -16.5\text{ V}$
	± 0.1	± 0.6	± 1	nA max	$V_S = \pm 10\text{ V}$, $V_D = \mp 10\text{ V}$; see Figure 21
Drain Off Leakage, I_D (Off)	± 0.02			nA typ	$V_S = \pm 10\text{ V}$, $V_D = \mp 10\text{ V}$; see Figure 21
	± 0.1	± 0.6	± 1	nA max	
Channel On Leakage, I_D , I_S (On)	± 0.02			nA typ	$V_S = V_D = \pm 10\text{ V}$; see Figure 22
	± 0.1	± 0.6	± 1	nA max	
DIGITAL INPUTS					
Input High Voltage, V_{INH}			2.0	V min	
Input Low Voltage, V_{INL}			0.8	V max	
Input Current, I_{INL} or I_{INH}	0.005			μA typ	$V_{IN} = V_{INL}$ or V_{INH}
			± 0.1	μA max	
Digital Input Capacitance, C_{IN}	2.5			pF typ	
DYNAMIC CHARACTERISTICS²					
t_{ON}	110			ns typ	$R_L = 300\ \Omega$, $C_L = 35\text{ pF}$
	130	160	195	ns max	$V_S = 10\text{ V}$; see Figure 23
t_{OFF}	85			ns typ	$R_L = 300\ \Omega$, $C_L = 35\text{ pF}$
	115	130	150	ns max	$V_S = 10\text{ V}$; see Figure 23
Break-Before-Make Time Delay, t_D (ADG1213 Only)	25		10	ns typ	$R_L = 300\ \Omega$, $C_L = 35\text{ pF}$
				ns min	$V_{S1} = V_{S2} = 10\text{ V}$; see Figure 24
Charge Injection	-0.3			pC typ	$V_S = 0\text{ V}$, $R_S = 0\ \Omega$, $C_L = 1\text{ nF}$; see Figure 25
Off Isolation	80			dB typ	$R_L = 50\ \Omega$, $C_L = 5\text{ pF}$, $f = 1\text{ MHz}$; see Figure 26
Channel-to-Channel Crosstalk	90			dB typ	$R_L = 50\ \Omega$, $C_L = 5\text{ pF}$, $f = 1\text{ MHz}$; see Figure 27
Total Harmonic Distortion + Noise	0.15			% typ	$R_L = 10\text{ k}\Omega$, 5 V rms , $f = 20\text{ Hz}$ to 20 kHz
-3 dB Bandwidth	1000			MHz typ	$R_L = 50\ \Omega$, $C_L = 5\text{ pF}$; see Figure 28
C_S (Off)	0.9			pF typ	$V_S = 0\text{ V}$, $f = 1\text{ MHz}$
	1.1			pF max	$V_S = 0\text{ V}$, $f = 1\text{ MHz}$
C_D (Off)	1			pF typ	$V_S = 0\text{ V}$, $f = 1\text{ MHz}$
	1.2			pF max	$V_S = 0\text{ V}$, $f = 1\text{ MHz}$
C_D , C_S (On)	2.6			pF typ	$V_S = 0\text{ V}$, $f = 1\text{ MHz}$
	3			pF max	$V_S = 0\text{ V}$, $f = 1\text{ MHz}$

Parameter	25°C	Y Version ¹		Unit	Test Conditions/Comments
		-40°C to +85°C	-40°C to +125°C		
POWER REQUIREMENTS					$V_{DD} = +16.5\text{ V}$, $V_{SS} = -16.5\text{ V}$
I_{DD}	0.001		1.0	$\mu\text{A typ}$ $\mu\text{A max}$	Digital inputs = 0 V or V_{DD}
I_{DD}	220		380	$\mu\text{A typ}$ $\mu\text{A max}$	Digital inputs = 5 V
I_{SS}	0.001		1.0	$\mu\text{A typ}$ $\mu\text{A max}$	Digital inputs = 0 V or V_{DD}
I_{SS}	0.001		1.0	$\mu\text{A typ}$ $\mu\text{A max}$	Digital inputs = 5 V
VDD/VSS			$\pm 4.5/\pm 16.5$	V min/max	

¹ Temperature range for Y version is -40°C to +125°C.

² Guaranteed by design, not subject to production test.

SINGLE SUPPLY

$V_{DD} = 12\text{ V} \pm 10\%$, $V_{SS} = 0\text{ V}$, $GND = 0\text{ V}$, unless otherwise noted.

Table 2.

Parameter	Y Version ¹			Unit	Test Conditions/Comments
	25°C	–40°C to +85°C	–40°C to +125°C		
ANALOG SWITCH					
Analog Signal Range			0 V to V_{DD}	V	
On Resistance (R_{ON})	300			Ω typ	$V_S = 0\text{ V to }10\text{ V}$, $I_S = -1\text{ mA}$; see Figure 20
	475	567	625	Ω max	$V_{DD} = 10.8\text{ V}$, $V_{SS} = 0\text{ V}$
On Resistance Match Between Channels (ΔR_{ON})	4.5			Ω typ	$V_S = 0\text{ V to }10\text{ V}$, $I_S = -1\text{ mA}$
	12	26	27	Ω max	
On Resistance Flatness ($R_{FLAT(ON)}$)	60			Ω typ	$V_S = 3\text{ V}/6\text{ V}/9\text{ V}$, $I_S = -1\text{ mA}$
LEAKAGE CURRENTS					
Source Off Leakage, I_S (Off)	± 0.02			nA typ	$V_{DD} = 13.2\text{ V}$, $V_{SS} = 0\text{ V}$
	± 0.1	± 0.6	± 1	nA max	$V_S = 1\text{ V}/10\text{ V}$, $V_D = 10\text{ V}/1\text{ V}$; see Figure 21
Drain Off Leakage, I_D (Off)	± 0.02			nA typ	$V_S = 1\text{ V}/10\text{ V}$, $V_D = 10\text{ V}/1\text{ V}$; see Figure 21
	± 0.1	± 0.6	± 1	nA max	
Channel On Leakage, I_D , I_S (On)	± 0.02			nA typ	$V_S = V_D = 1\text{ V or }10\text{ V}$; see Figure 22
	± 0.1	± 0.6	± 1	nA max	
DIGITAL INPUTS					
Input High Voltage, V_{INH}			2.0	V min	
Input Low Voltage, V_{INL}			0.8	V max	
Input Current, I_{INL} or I_{INH}	0.001			μA typ	$V_{IN} = V_{INL}$ or V_{INH}
			± 0.1	μA max	
Digital Input Capacitance, C_{IN}	3			pF typ	
DYNAMIC CHARACTERISTICS²					
t_{ON}	130			ns typ	$R_L = 300\ \Omega$, $C_L = 35\text{ pF}$
	170	210	240	ns max	$V_S = 8\text{ V}$; see Figure 23
t_{OFF}	95			ns typ	$R_L = 300\ \Omega$, $C_L = 35\text{ pF}$
	120	145	180	ns max	$V_S = 8\text{ V}$; see Figure 23
Break-Before-Make Time Delay, t_D (ADG1213 Only)	50		10	ns typ	$R_L = 300\ \Omega$, $C_L = 35\text{ pF}$
				ns min	$V_{S1} = V_{S2} = 8\text{ V}$; see Figure 24
Charge Injection	0			pC typ	$V_S = 6\text{ V}$, $R_S = 0\ \Omega$, $C_L = 1\text{ nF}$; see Figure 25
Off Isolation	80			dB typ	$R_L = 50\ \Omega$, $C_L = 5\text{ pF}$, $f = 1\text{ MHz}$; see Figure 26
Channel-to-Channel Crosstalk	90			dB typ	$R_L = 50\ \Omega$, $C_L = 5\text{ pF}$, $f = 1\text{ MHz}$; see Figure 27
–3 dB Bandwidth	900			MHz typ	$R_L = 50\ \Omega$, $C_L = 5\text{ pF}$; see Figure 28
C_S (Off)	1.2			pF typ	$V_S = 6\text{ V}$, $f = 1\text{ MHz}$
	1.4			pF max	$V_S = 6\text{ V}$, $f = 1\text{ MHz}$
C_D (Off)	1.3			pF typ	$V_S = 6\text{ V}$, $f = 1\text{ MHz}$
	1.5			pF max	$V_S = 6\text{ V}$, $f = 1\text{ MHz}$
C_D , C_S (On)	3.2			pF typ	$V_S = 6\text{ V}$, $f = 1\text{ MHz}$
	3.9			pF max	$V_S = 6\text{ V}$, $f = 1\text{ MHz}$
POWER REQUIREMENTS					
I_{DD}	0.001			μA typ	$V_{DD} = 13.2\text{ V}$
			1.0	μA max	Digital inputs = 0 V or V_{DD}
I_{DD}	220			μA typ	Digital inputs = 5 V
			1.0	μA max	
VDD			5/16.5	V min/max	$V_{SS} = 0\text{ V}$, $GND = 0\text{ V}$

¹ Temperature range for Y version is –40°C to +125°C.

² Guaranteed by design, not subject to production test.

ABSOLUTE MAXIMUM RATINGS

$T_A = 25^\circ\text{C}$, unless otherwise noted.

Table 3.

Parameter	Rating
V_{DD} to V_{SS}	35 V
V_{DD} to GND	-0.3 V to +25 V
V_{SS} to GND	+0.3 V to -25 V
Analog Inputs ¹	$V_{SS} - 0.3\text{ V}$ to $V_{DD} + 0.3\text{ V}$ or 30 mA, whichever occurs first
Digital Inputs ¹	GND - 0.3 V to $V_{DD} + 0.3\text{ V}$ or 30 mA, whichever occurs first
Peak Current, S or D	100 mA (pulsed at 1 ms, 10% duty cycle max)
Continuous Current per Channel, S or D	25 mA
Operating Temperature Range Automotive (Y Version)	-40°C to +125°C
Storage Temperature Range	-65°C to +150°C
Junction Temperature	150°C
16-Lead TSSOP, θ_{JA} Thermal Impedance (4-Layer Board)	112°C/W
16-Lead LFCSP, θ_{JA} Thermal Impedance	72.7°C/W
Reflow Soldering Peak Temperature, Pb free	260°C

¹ Overvoltages at IN, S, or D are clamped by internal diodes. Current must be limited to the maximum ratings given.

Stresses at or above those listed under Absolute Maximum Ratings may cause permanent damage to the product. This is a stress rating only; functional operation of the product at these or any other conditions above those indicated in the operational section of this specification is not implied. Operation beyond the maximum operating conditions for extended periods may affect product reliability.

Only one absolute maximum rating can be applied at any one time.

Table 4. ADG1211/ADG1212 Truth Table

ADG1211 INx	ADG1212 INx	Switch Condition
0	1	On
1	0	Off

Table 5. ADG1213 Truth Table

ADG1213 INx	Switch 1, 4	Switch 2, 3
0	Off	On
1	On	Off

ESD CAUTION



ESD (electrostatic discharge) sensitive device. Charged devices and circuit boards can discharge without detection. Although this product features patented or proprietary protection circuitry, damage may occur on devices subjected to high energy ESD. Therefore, proper ESD precautions should be taken to avoid performance degradation or loss of functionality.

PIN CONFIGURATIONS AND FUNCTION DESCRIPTIONS

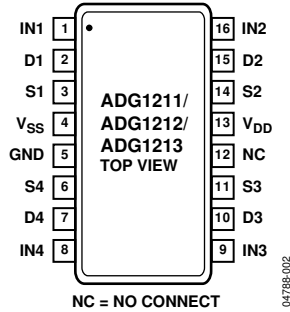
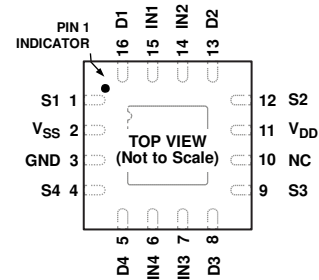

Figure 2. TSSOP Pin Configuration

ADG1211/ADG1212/ADG1213



- NOTES
1. NC = NO CONNECT. DO NOT CONNECT TO THIS PIN.
 2. THE EXPOSED PAD MUST BE TIED TO SUBSTRATE, V_{SS} .

Figure 3. LFCSP Pin Configuration

Table 6. Pin Function Descriptions

Pin No.		Mnemonic	Description
TSSOP	LFCSP		
1	15	IN1	Logic Control Input.
2	16	D1	Drain Terminal. Can be an input or output.
3	1	S1	Source Terminal. Can be an input or output.
4	2	V_{SS}	Most Negative Power Supply Potential.
5	3	GND	Ground (0 V) Reference.
6	4	S4	Source Terminal. Can be an input or output.
7	5	D4	Drain Terminal. Can be an input or output.
8	6	IN4	Logic Control Input.
9	7	IN3	Logic Control Input.
10	8	D3	Drain Terminal. Can be an input or output.
11	9	S3	Source Terminal. Can be an input or output.
12	10	NC	No Internal Connection.
13	11	V_{DD}	Most Positive Power Supply Potential.
14	12	S2	Source Terminal. Can be an input or output.
15	13	D2	Drain Terminal. Can be an input or output.
16	14	IN2	Logic Control Input.

TERMINOLOGY

I_{DD}

The positive supply current.

I_{SS}

The negative supply current.

V_D (V_S)

The analog voltage on Terminals D and S.

R_{ON}

The ohmic resistance between D and S.

R_{FLAT(ON)}

Flatness is defined as the difference between the maximum and minimum value of on resistance, as measured over the specified analog signal range.

I_S (Off)

The source leakage current with the switch off.

I_D (Off)

The drain leakage current with the switch off.

I_D, I_S (On)

The channel leakage current with the switch on.

V_{INL}

The maximum input voltage for Logic 0.

V_{INH}

The minimum input voltage for Logic 1.

I_{INL} (I_{INH})

The input current of the digital input.

C_S (Off)

The off switch source capacitance, measured with reference to ground.

C_D (Off)

The off switch drain capacitance, measured with reference

to ground.

C_D, C_S (On)

The on switch capacitance, measured with reference to ground.

C_{IN}

The digital input capacitance.

t_{ON}

The delay between applying the digital control input and the output switching on. See Figure 23.

t_{OFF}

The delay between applying the digital control input and the output switching off. See Figure 23.

Charge Injection

A measure of the glitch impulse transferred from the digital input to the analog output during switching.

Off Isolation

A measure of unwanted signal coupling through an off switch.

Crosstalk

A measure of unwanted signal that is coupled through from one channel to another as a result of parasitic capacitance.

Bandwidth

The frequency at which the output is attenuated by 3 dB.

On Response

The frequency response of the on switch.

Insertion Loss

The loss due to the on resistance of the switch.

THD + N

The ratio of the harmonic amplitude plus noise of the signal to the fundamental.

TYPICAL PERFORMANCE CHARACTERISTICS

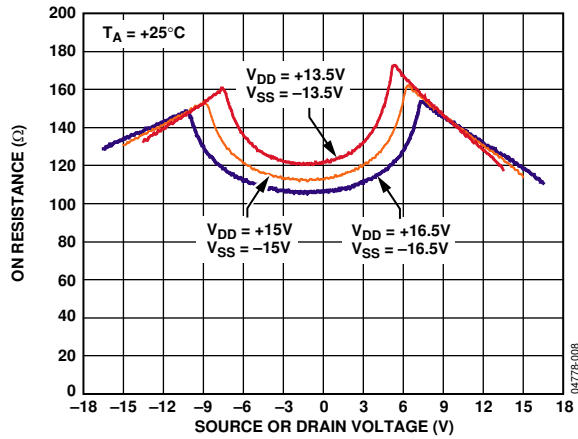

Figure 4. On Resistance as a Function of V_D (V_S) for Dual Supply

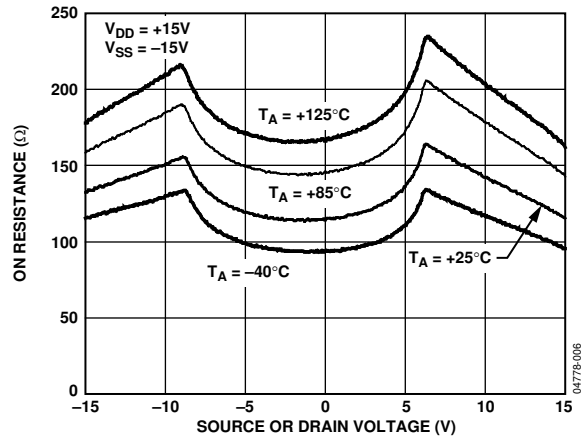

Figure 7. On Resistance as a Function of V_D (V_S) for Different Temperatures, Dual Supply

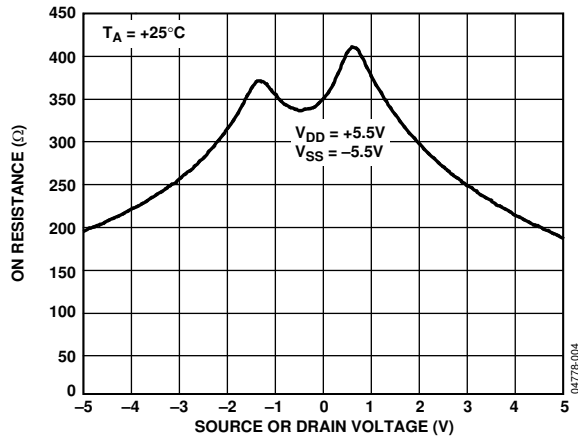

Figure 5. On Resistance as a Function of V_D (V_S) for Dual Supply

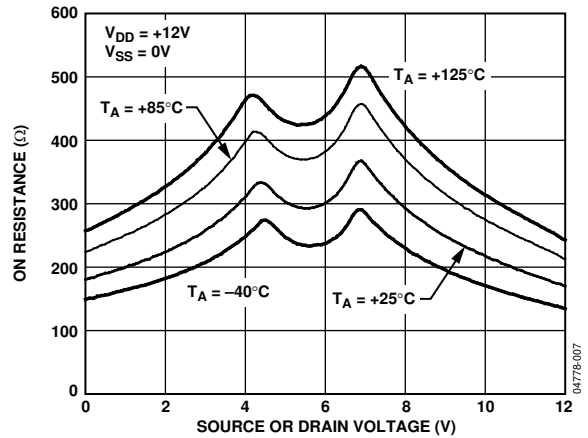

Figure 8. On Resistance as a Function of V_D (V_S) for Different Temperatures, Single Supply

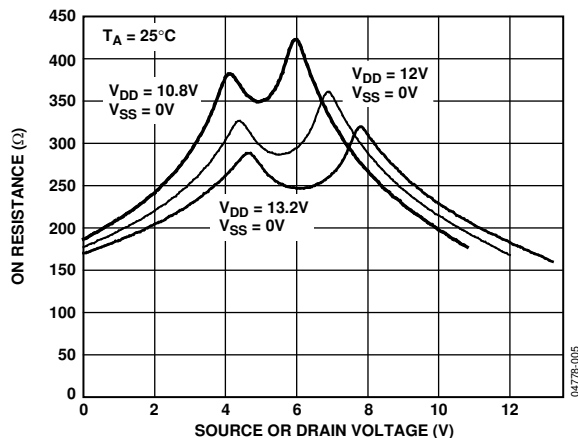

Figure 6. On Resistance as a Function of V_D (V_S) for Single Supply

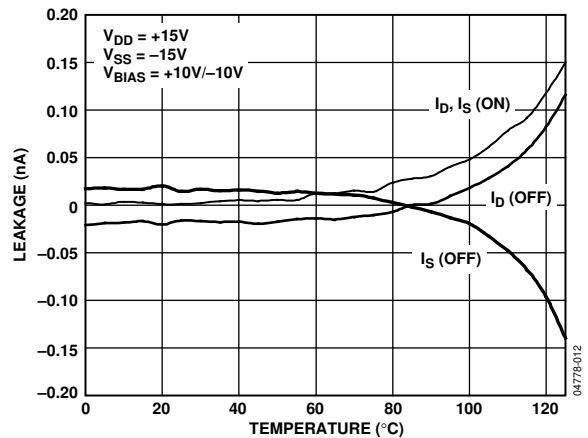

Figure 9. Leakage Currents as a Function of Temperature, Dual Supply

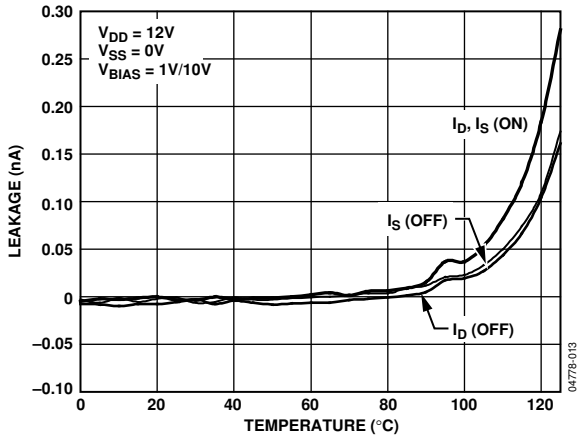

Figure 10. Leakage Currents as a Function of Temperature, Single Supply

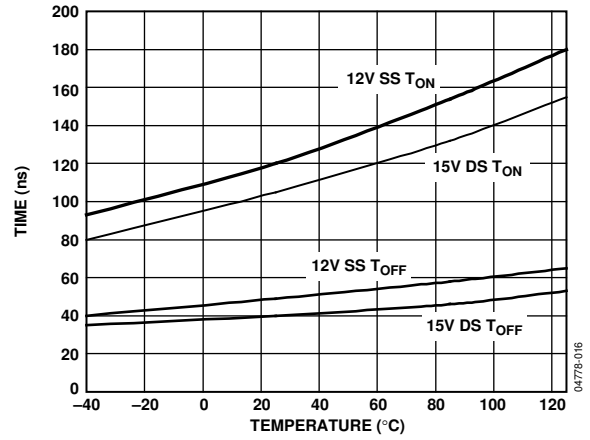

Figure 13. T_{ON}/T_{OFF} Times vs. Temperature

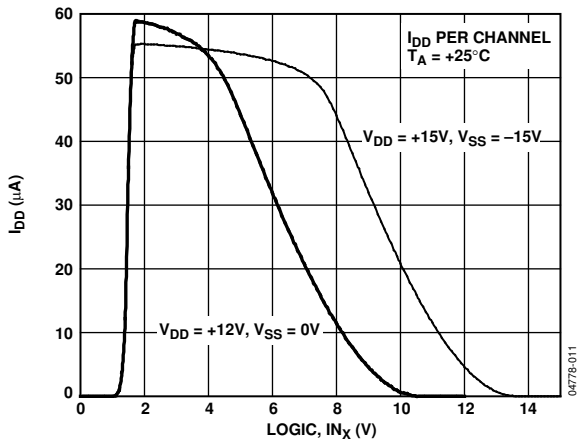

Figure 11. I_{DD} vs. Logic Level

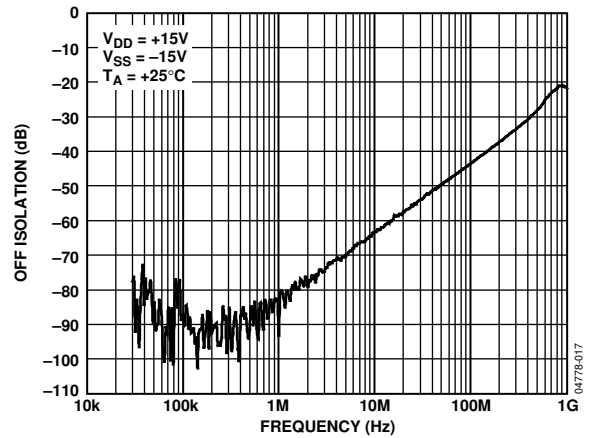

Figure 14. Off Isolation vs. Frequency

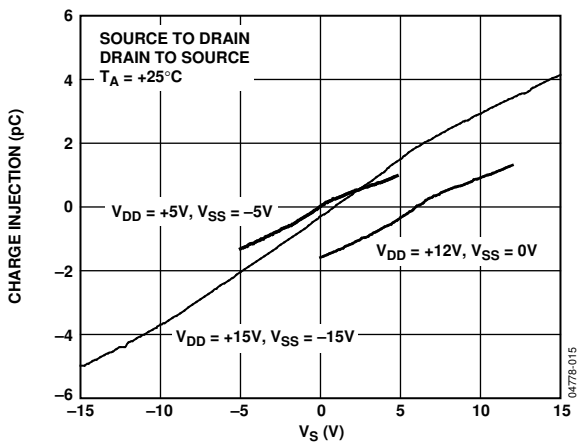

Figure 12. Charge Injection vs. Source Voltage

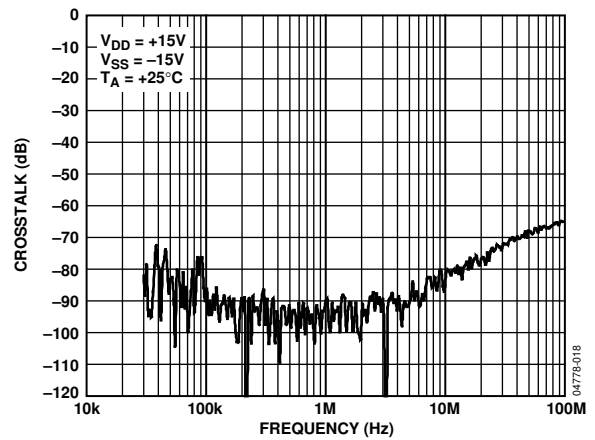

Figure 15. Crosstalk vs. Frequency

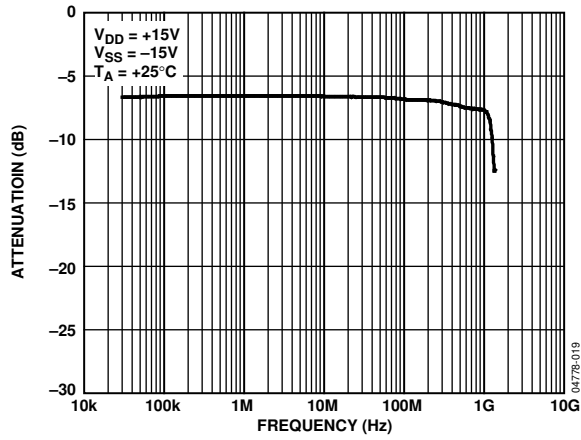

Figure 16. On Response vs. Frequency

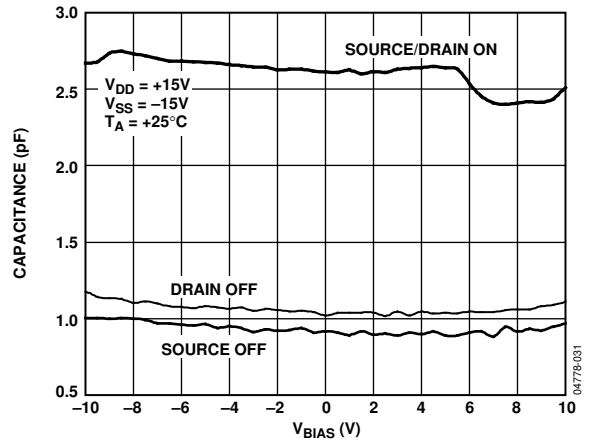

Figure 18. Capacitance vs. Source Voltage, Dual Supply

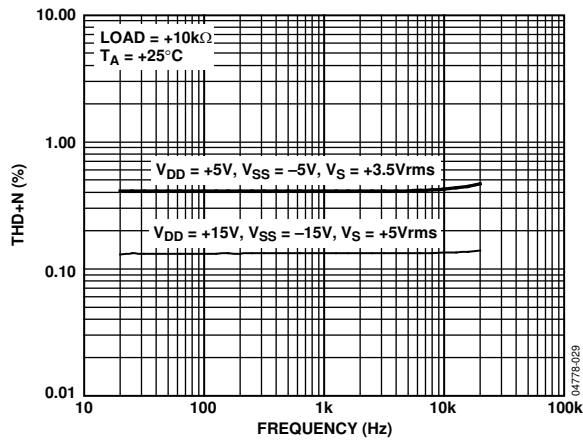

Figure 17. THD + N vs. Frequency

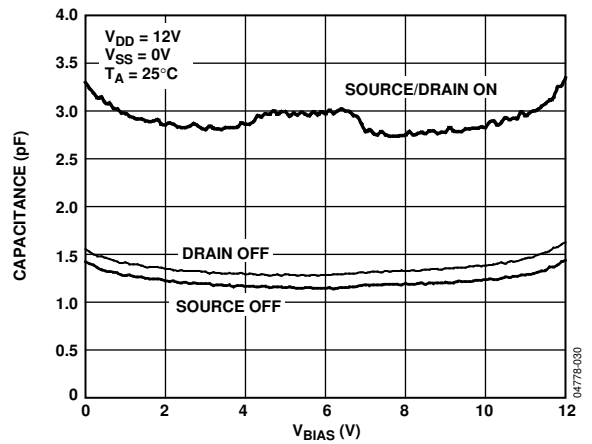

Figure 19. Capacitance vs. Source Voltage, Single Supply

TEST CIRCUITS

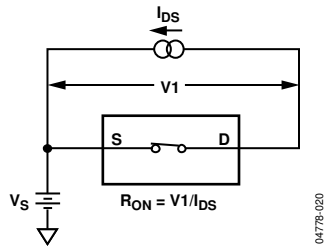

Figure 20. On Resistance

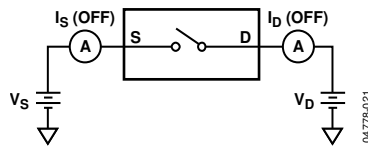

Figure 21. Off Leakage

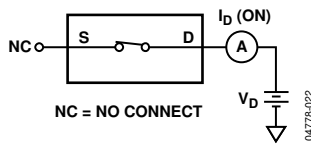

Figure 22. On Leakage

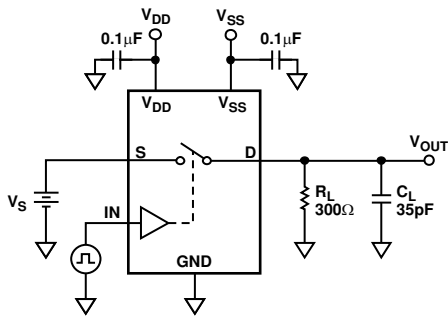

Figure 23. Switching Times

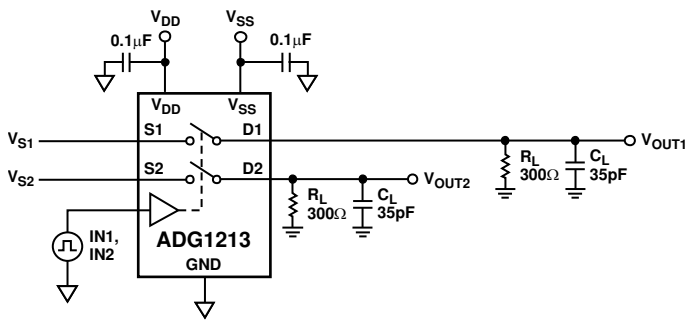
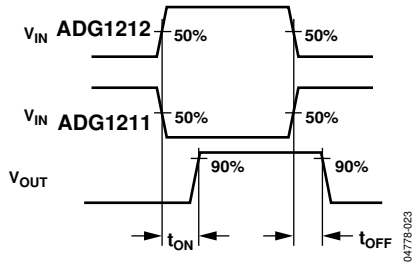
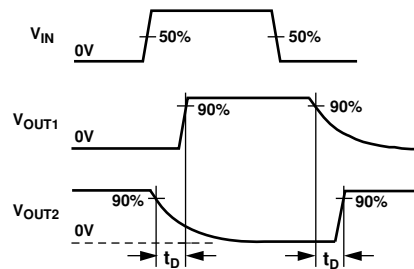

Figure 24. Break-Before-Make Time Delay



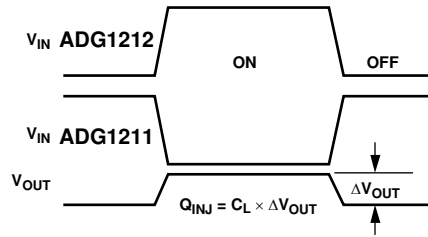
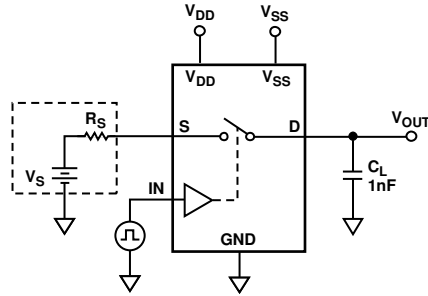
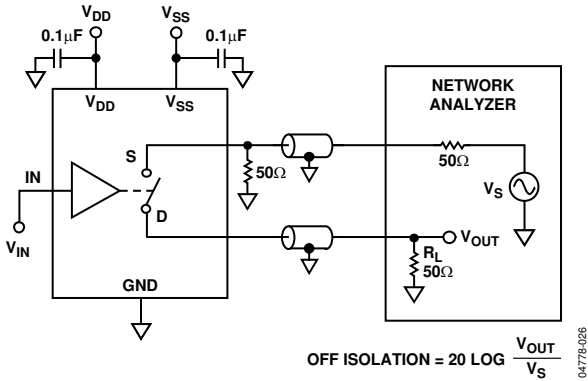
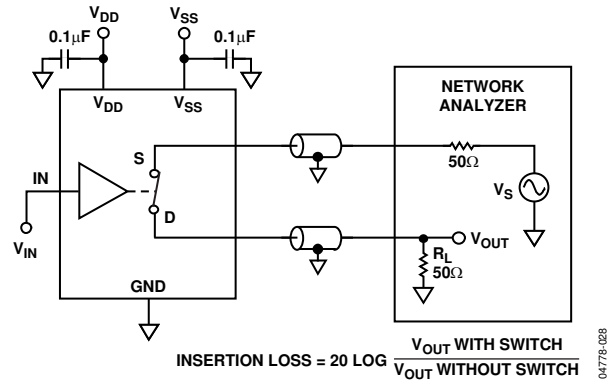

Figure 25. Charge Injection



OFF ISOLATION = $20 \text{ LOG } \frac{V_{OUT}}{V_S}$

Figure 26. Off Isolation



INSERTION LOSS = $20 \text{ LOG } \frac{V_{OUT \text{ WITH SWITCH}}}{V_{OUT \text{ WITHOUT SWITCH}}}$

Figure 28. Bandwidth

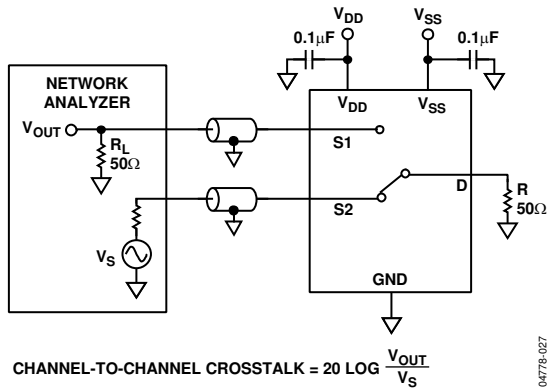

CHANNEL-TO-CHANNEL CROSSTALK = $20 \text{ LOG } \frac{V_{OUT}}{V_S}$

Figure 27. Channel-to-Channel Crosstalk

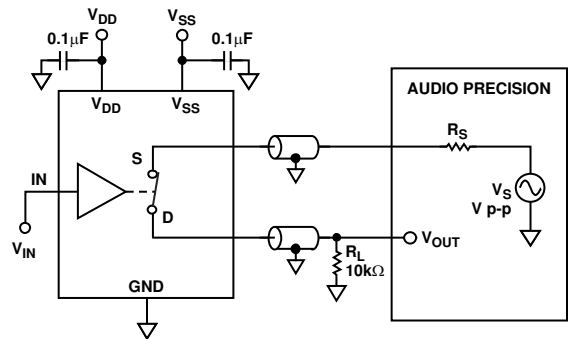
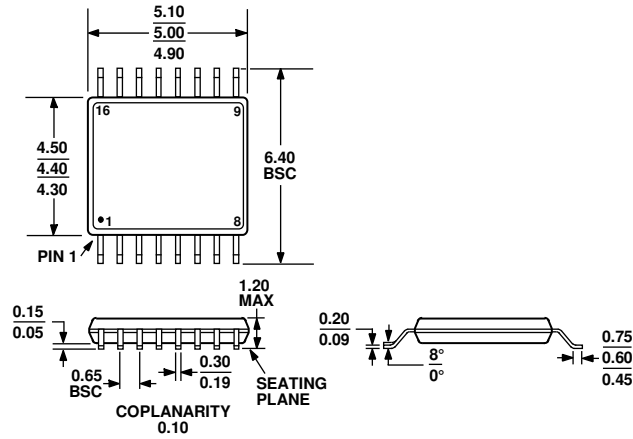

Figure 29. THD + Noise

OUTLINE DIMENSIONS



COMPLIANT TO JEDEC STANDARDS MO-153-AB

Figure 30. 16-Lead Thin Shrink Small Outline Package [TSSOP] (RU-16)

Dimensions shown in millimeters

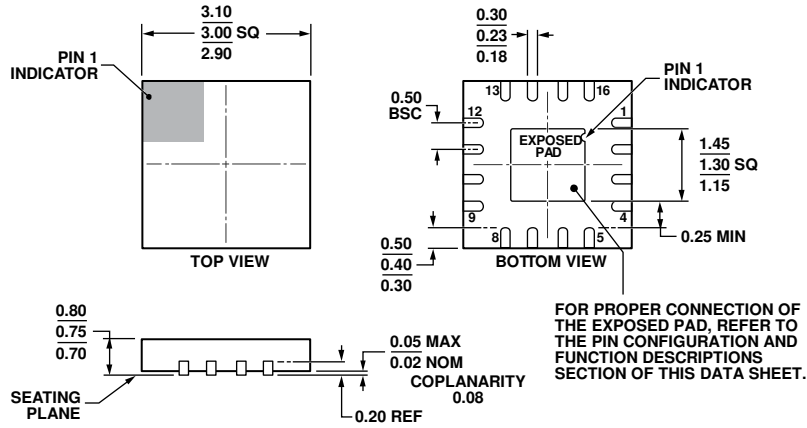

COMPLIANT TO JEDEC STANDARDS MO-220-WEED.

Figure 31. 16-Lead Lead Frame Chip Scale Package [LFCSP] 3 mm x 3 mm Body and 0.75 mm Package Height (CP-16-21)

Dimensions shown in millimeters

11169B-A

ORDERING GUIDE

Model ¹	Temperature Range	Package Description	Package Option	Branding
ADG1211YRUZ	-40°C to +125°C	Thin Shrink Small Outline Package [TSSOP]	RU-16	
ADG1211YRUZ-REEL	-40°C to +125°C	Thin Shrink Small Outline Package [TSSOP]	RU-16	
ADG1211YRUZ-REEL7	-40°C to +125°C	Thin Shrink Small Outline Package [TSSOP]	RU-16	
ADG1211YCPZ-500RL7	-40°C to +125°C	Lead Frame Chip Scale Package [LFCSP]	CP-16-21	S07
ADG1211YCPZ-REEL7	-40°C to +125°C	Lead Frame Chip Scale Package [LFCSP]	CP-16-21	S07
ADG1212YRUZ	-40°C to +125°C	Thin Shrink Small Outline Package [TSSOP]	RU-16	
ADG1212YRUZ-REEL7	-40°C to +125°C	Thin Shrink Small Outline Package [TSSOP]	RU-16	
ADG1212YCPZ-500RL7	-40°C to +125°C	Lead Frame Chip Scale Package [LFCSP]	CP-16-21	S08
ADG1212YCPZ-REEL7	-40°C to +125°C	Lead Frame Chip Scale Package [LFCSP]	CP-16-21	S08
ADG1213YRUZ	-40°C to +125°C	Thin Shrink Small Outline Package [TSSOP]	RU-16	
ADG1213YRUZ-REEL7	-40°C to +125°C	Thin Shrink Small Outline Package [TSSOP]	RU-16	
ADG1213YCPZ-500RL7	-40°C to +125°C	Lead Frame Chip Scale Package [LFCSP]	CP-16-21	S09
ADG1213YCPZ-REEL7	-40°C to +125°C	Lead Frame Chip Scale Package [LFCSP]	CP-16-21	S09

¹Z = RoHS Compliant Part.

NOTES