



Chipsmall Limited consists of a professional team with an average of over 10 year of expertise in the distribution of electronic components. Based in Hongkong, we have already established firm and mutual-benefit business relationships with customers from,Europe,America and south Asia,supplying obsolete and hard-to-find components to meet their specific needs.

With the principle of "Quality Parts,Customers Priority,Honest Operation,and Considerate Service",our business mainly focus on the distribution of electronic components. Line cards we deal with include Microchip,ALPS,ROHM,Xilinx,Pulse,ON,Everlight and Freescale. Main products comprise IC,Modules,Potentiometer,IC Socket,Relay,Connector.Our parts cover such applications as commercial,industrial, and automotives areas.

We are looking forward to setting up business relationship with you and hope to provide you with the best service and solution. Let us make a better world for our industry!



## Contact us

Tel: +86-755-8981 8866 Fax: +86-755-8427 6832

Email & Skype: info@chipsmall.com Web: www.chipsmall.com

Address: A1208, Overseas Decoration Building, #122 Zhenhua RD., Futian, Shenzhen, China



## FEATURES

- Fully operational down to 0 Hz/dc
  - On resistance: 1.8  $\Omega$  (typical)
  - Off leakage: 0.5 nA (maximum)
- 3 dB bandwidth
  - 13 GHz (typical) for RF2, RF3
  - 10.8 GHz (typical) for RF1, RF4
- RF performance characteristics
  - Insertion loss: 0.45 dB (typical) at 2.5 GHz
  - Isolation: 24 dB (typical) at 2.5 GHz
  - IIP3: 67 dBm (typical)
  - Radio frequency (RF) power: 32 dBm (maximum)
- Actuation lifetime: 1 billion cycles (minimum)
  - Hermetically sealed switch contacts
  - On switching time: 30  $\mu$ s (typical)
- Electrostatic discharge (ESD) human body model (HBM) rating
  - 5 kV for RF1 to RF4 and RFC pins
  - 2.5 kV for all other pins
- Integrated driver removes the need for an external driver
  - Supply voltage: 3.1 V to 3.3 V
  - CMOS/LVTTL compatible
  - Parallel interface
  - Independently controllable switches
- 5 mm  $\times$  4 mm  $\times$  1.45 mm, 24-lead LFCSP

## APPLICATIONS

- Relay replacements
- Automatic test equipment (ATE): RF/digital/mixed signals
- Load/probe boards: RF/digital/mixed signals
- Radio frequency (RF) test instrumentation
- Reconfigurable filters/attenuators
- High performance RF switching

## GENERAL DESCRIPTION

The ADGM1004 is a wideband, single-pole, four-throw (SP4T) switch, fabricated using Analog Devices, Inc., microelectro-mechanical system (MEMS) switch technology. This technology enables a small form factor, wide RF bandwidth, highly linear, low insertion loss switch that is operational down to 0 Hz/dc, making it an ideal solution for a wide range of RF and precision equipment switching needs.

An integrated control chip generates the high voltage necessary to electrostatically actuate the switch via a complementary metal-oxide semiconductor (CMOS)-/low voltage transistor-transistor logic (LVTTL)-compatible parallel interface. All four switches are independently controllable.

The device is packaged in a 24-lead, 5 mm  $\times$  4 mm  $\times$  1.45 mm lead frame chip-scale package (LFCSP).

## FUNCTIONAL BLOCK DIAGRAM

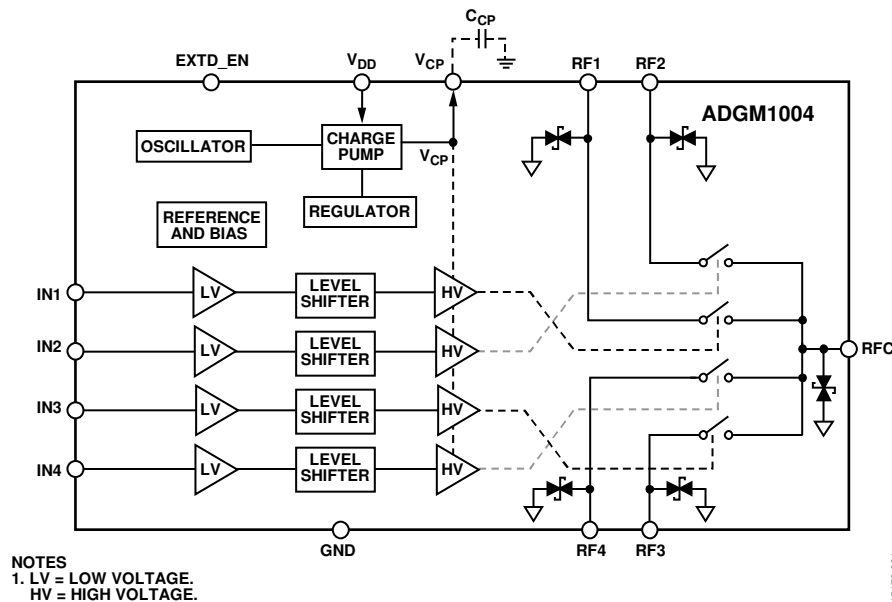

Figure 1.

# ADGM1004\* PRODUCT PAGE QUICK LINKS

Last Content Update: 02/23/2017

---

## COMPARABLE PARTS

View a parametric search of comparable parts.

## EVALUATION KITS

- ADGM1004 Evaluation Board

## DOCUMENTATION

### Data Sheet

- ADGM1004: 0 Hz/DC to 13 GHz, 2.5 kV HBM ESD SP4T, MEMS Switch with Integrated Driver Data Sheet

### User Guides

- UG-1078: Evaluating the ADGM1004 0 Hz/DC to 13 GHz, 2.5 kV HBM ESD, SP4T, MEMS Switch with Integrated Driver User Guide

## TOOLS AND SIMULATIONS

- ADGM1004 S-Parameter

## REFERENCE MATERIALS

### Press

- Analog Devices Makes MEMS Switch Technology a Commercial Reality

### Technical Articles

- The Fundamentals of Analog Devices' Revolutionary MEMS Switch Technology

## DESIGN RESOURCES

- ADGM1004 Material Declaration
- PCN-PDN Information
- Quality And Reliability
- Symbols and Footprints

## DISCUSSIONS

View all ADGM1004 EngineerZone Discussions.

## SAMPLE AND BUY

Visit the product page to see pricing options.

## TECHNICAL SUPPORT

Submit a technical question or find your regional support number.

## DOCUMENT FEEDBACK

Submit feedback for this data sheet.

## TABLE OF CONTENTS

Features .....	1	Internal Oscillator/EXTD_EN.....	15
Applications.....	1	Typical Operating Circuit .....	15
General Description .....	1	Applications Information .....	16
Functional Block Diagram .....	1	Floating Node Avoidance .....	16
Revision History .....	2	Continuously on Lifetime .....	17
Specifications.....	3	Suggested Application Circuits.....	18
Absolute Maximum Ratings.....	5	Switchable RF Attenuator.....	18
Thermal Resistance .....	5	Reconfigurable RF Filter .....	18
ESD Caution.....	5	Handling Guidelines .....	19
Pin Configuration and Function Descriptions.....	6	Electrical Overstress (EOS) Precautions .....	19
Typical Performance Characteristics .....	7	DC Voltage Range .....	19
Test Circuits.....	10	Mechanical Shock Precautions .....	19
Terminology .....	12	Outline Dimensions .....	20
Theory of Operation .....	14	Ordering Guide .....	20
Digital Interface .....	14		

## REVISION HISTORY

### 2/2017—Rev. 0 to Rev. A

Changes to Features Section.....	1
Changes to On Resistance Parameter, Table 1 .....	3
Change to Table 2 .....	5
Changes to Figure 13 and Figure 14.....	8
Updated Outline Dimensions .....	20

### 1/2017—Revision 0: Initial Version

## SPECIFICATIONS

$V_{DD} = 3.1 \text{ V to } 3.3 \text{ V}$ ,  $GND = 0 \text{ V}$ , all specifications at  $25^\circ\text{C}$ , unless otherwise noted.

Table 1.

Parameter	Symbol	Min	Typ <sup>1</sup>	Max	Unit	Test Conditions/Comments <sup>2</sup>
<b>DYNAMIC CHARACTERISTICS</b>						
-3 dB Bandwidth	BW					
RF1, RF4		9.5	10.8		GHz	RF1 to RFC and RF4 to RFC channels
RF2, RF3		11.5	13		GHz	RF2 to RFC and RF3 to RFC channels
Insertion Loss <sup>3</sup>	IL		0.45	0.6	dB	At 2.5 GHz; RFC to RFx
			0.63	0.95	dB	At 6.0 GHz; RFC to RFx
Isolation <sup>3</sup>	$I_{SO}$	22	24		dB	At 2.5 GHz; RFC to RFx
		16	19		dB	At 6.0 GHz; RFC to RFx
Crosstalk <sup>3</sup>	$C_{TK}$	27	30		dB	At 2.5 GHz; RFx to RFx
		22	24		dB	At 6.0 GHz; RFx to RFx
Return Loss <sup>3</sup>	RL	14	17		dB	DC to 6.0 GHz
Third-Order Intermodulation Intercept <sup>3</sup>	IIP3		67		dBm	Input: 900 MHz and 901 MHz; input power = 27 dBm
Second-Order Intermodulation Intercept <sup>3</sup>	IIP2		95		dBm	Input: 900 MHz and 901 MHz; input power = 27 dBm
Second Harmonic <sup>3</sup>	HD2		-90		dBc	Input: 5.4 MHz; input power = 0 dBm
			-74		dBc	Input: 150 MHz and 800 MHz; input power = 27 dBm
Third Harmonic <sup>3</sup>	HD3		-80		dBc	Input: 150 MHz and 800 MHz; input power = 27 dBm
Total Harmonic Distortion <sup>3</sup>	THD + N		-102		dBc	$R_L = 300 \Omega$ , $f = 1 \text{ kHz}$ , $RFx = 2.5 \text{ V p-p}$
Maximum RF Power <sup>3</sup>				32	dBm	Switch in the on state and terminated into $50 \Omega$ , $0^\circ\text{C}$ to $85^\circ\text{C}$
DC Voltage Range		-6		+6	V	On switch dc voltage operation range, $0^\circ\text{C}$ to $85^\circ\text{C}$
On Switching Time	$t_{ON}$		30	75	$\mu\text{s}$	50% INx to 90% RFx, $50 \Omega$ termination, $0^\circ\text{C}$ to $85^\circ\text{C}$
Off Switching Time	$t_{OFF}$		5	30	$\mu\text{s}$	50% INx to 10% RFx, $50 \Omega$ termination, $0^\circ\text{C}$ to $85^\circ\text{C}$
Settling Time						
Rising Edge			40		$\mu\text{s}$	50% INx to 0.05 dB final IL value, $50 \Omega$ termination
Falling Edge			10		$\mu\text{s}$	50% INx to 0.05 dB final IL value, $50 \Omega$ termination
Actuation Frequency <sup>3</sup>				5	kHz	All switches toggled simultaneously; $0^\circ\text{C}$ to $85^\circ\text{C}$
Power-Up Time			0.55		ms	$C_{CP} = 47 \text{ pF}$ ; 95% $V_{DD}$ to 90% RFx; $0^\circ\text{C}$ to $85^\circ\text{C}$
Video Feedthrough <sup>3</sup>			16		mV peak	1 M $\Omega$ termination
Internal Oscillator Frequency		6		16	MHz	$0^\circ\text{C}$ to $85^\circ\text{C}$
Internal Oscillator Feedthrough <sup>3,4</sup>			-115		dBm	Spectrum analyzer resolution bandwidth (RBW) = 200 Hz; one switch in on state, all others off with $50 \Omega$ terminations
<b>SWITCH PROPERTIES</b>						
On Resistance	$R_{ON}$		1.8	3.5	$\Omega$	$I_{DS}^5 = 50 \text{ mA}$ , 0 V input bias, at 1 ms after actuation, maximum specification from $0^\circ\text{C}$ to $85^\circ\text{C}$
On Resistance Variation Over Actuations	$\Delta R_{ON}$		1.4		$\Omega$	$10^9$ actuations; from $0^\circ\text{C}$ to $85^\circ\text{C}$ ; 1 kHz cycling frequency; 220 mA load between toggles

Parameter	Symbol	Min	Typ <sup>1</sup>	Max	Unit	Test Conditions/Comments <sup>2</sup>
Between Channels	$\Delta R_{ON\ CH\_CH}$		0.25	1	$\Omega$	Maximum value tested from 0°C to 85°C
Over Time	$\Delta R_{ON\ TIME}$		-0.11	-0.32	$\Omega$	$R_{ON}$ change from 1 ms to 100 ms after actuation; maximum value tested from 0°C to 85°C
On Resistance Repeatability	$\Delta R_{ON\ REP}$		0.01		$\Omega$	1 on/off/on actuation cycle
On Resistance Input Voltage Bias	$\Delta R_{ON\ VBIAS}$		0.17		$\Omega$	$I_{DS} = 50$ mA, from -6 V to +6 V input bias
RF Port						
On Capacitance <sup>3</sup>	$C_{RF\ ON}$		3		pF	At 1 MHz
Off Capacitance <sup>3</sup>	$C_{RF\ OFF}$		1.5		pF	At 1 MHz
On Leakage				5	nA	RFx (off channels) = 6 V; RFC/RFx (on channel) = -6 V; maximum specification from 0°C to 85°C
Off Leakage				0.5	nA	RFx = 6 V; RFC = -6 V; maximum specification from 0°C to 85°C
Continuously On Lifetime <sup>3</sup>			7.2		Years	Median time before failure <sup>6</sup> at 50°C
Actuation Lifetime <sup>3</sup>		$10^9$			Cycles	Cold switched; load between toggling is 220 mA; tested at 85°C
DIGITAL INPUTS						Minimum and maximum over 0°C to 85°C
Input High Voltage	$V_{INH}$	2			V	
Input Low Voltage	$V_{INL}$			0.8	V	
Input Current	$I_{INL}/I_{INH}$		0.025	1	$\mu$ A	$V_{IN} = V_{INL}$ or $V_{INH}$
POWER REQUIREMENTS						Minimum and maximum over 0°C to 85°C
Voltage	$V_{DD}$	3.1		3.3	V	
Current	$I_{DD}$		3	4	mA	$V_{DD} = 3.3$ V; digital inputs = 0 V or $V_{DD}$

<sup>1</sup> Typical specifications tested at 25°C with  $V_{DD} = 3.3$  V.

<sup>2</sup> RFx is RF1, RF2, RF3, and RF4. INx is IN1, IN2, IN3, and IN4.

<sup>3</sup> Guaranteed by design, but not subject to production test.

<sup>4</sup> Disable the internal oscillator to eliminate feedthrough.

<sup>5</sup>  $I_{DS}$  is the drain source current.

<sup>6</sup> This value shows the median time it takes for 50% of a sample lot to fail.

## ABSOLUTE MAXIMUM RATINGS

$T_A = 25^\circ\text{C}$ , unless otherwise noted.

**Table 2.**

Parameter	Rating
$V_{DD}$ to GND	-0.3 V to +6 V
Digital Inputs <sup>1</sup>	-0.3 V to $V_{DD} + 0.3$ V or 30 mA (whichever occurs first)
DC Voltage Rating <sup>2</sup>	$\pm 10$ V
Current Rating <sup>2</sup>	250 mA
RF Power Rating <sup>3</sup>	33 dBm
Operating Temperature Range	$0^\circ\text{C}$ to $+85^\circ\text{C}$
Storage Temperature Range	$-65^\circ\text{C}$ to $+150^\circ\text{C}$
Reflow Soldering (Pb-Free)	
Peak Temperature	260 (+0/-5) $^\circ\text{C}$
Time at Peak Temperature	10 sec to 30 sec
ESD	
Human Body Model	
RF1 to RF4 and RFC Pins	5 kV
All Other Pins	2.5 kV
Field Induced Charged Device Model <sup>4</sup>	
All Pins	1.25 kV
Group D	
Mechanical Shock <sup>5</sup>	1500 g with 0.5 ms pulse
Vibration	20 Hz to 2000 Hz acceleration at 50 g
Constant Acceleration	30,000 g

<sup>1</sup> Clamp overvoltages at INx by internal diodes. Limit the current to the maximum ratings given.

<sup>2</sup> This rating is with respect to the switch in the on position with no radio frequency signal applied.

<sup>3</sup> This rating is with respect to the switch in the on position and terminated into 50  $\Omega$ . The rating is 27 dBm when the switch is unterminated.

<sup>4</sup> A safe automated handling and assembly process is achieved at this rating level by implementing industry-standard ESD controls.

<sup>5</sup> If the device is dropped during handling, do not use the device.

Stresses at or above those listed under Absolute Maximum Ratings may cause permanent damage to the product. This is a stress rating only; functional operation of the product at these or any other conditions above those indicated in the operational section of this specification is not implied. Operation beyond the maximum operating conditions for extended periods may affect product reliability.

Only one absolute maximum rating can be applied at any one time.

## THERMAL RESISTANCE

Thermal performance is directly linked to printed circuit board (PCB) design and operating environment. Careful attention to PCB thermal design is required.

$\theta_{JA}$  is the natural convection junction to ambient thermal resistance measured in a one cubic foot sealed enclosure.

$\theta_{JC}$  is the junction to case thermal resistance.

**Table 3. Thermal Resistance**

Package Type	$\theta_{JA}$	$\theta_{JC}$	Unit
CP-24-4 <sup>1</sup>	60	75	$^\circ\text{C}/\text{W}$

<sup>1</sup> A simulated  $\theta_{JA}$  number is evaluated using the maximum junction temperature in the package and the total power being dissipated in the package under operating conditions. For thermal performance calculation purposes at  $25^\circ\text{C}$ , a power dissipation of 113 mW per switch can be used. This value is calculated from a typical  $R_{ON}$  of 1.8  $\Omega$  and an absolute maximum current rating of 250 mA.

## ESD CAUTION



**ESD (electrostatic discharge) sensitive device.** Charged devices and circuit boards can discharge without detection. Although this product features patented or proprietary protection circuitry, damage may occur on devices subjected to high energy ESD. Therefore, proper ESD precautions should be taken to avoid performance degradation or loss of functionality.

## PIN CONFIGURATION AND FUNCTION DESCRIPTIONS

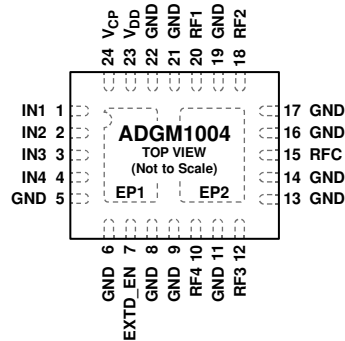

## NOTES

1. EXPOSED PAD 1. EP1 IS INTERNALLY CONNECTED TO EP2 AND MUST BE CONNECTED TO GND.
2. EXPOSED PAD 2. EP2 IS INTERNALLY CONNECTED TO EP1 AND MUST BE CONNECTED TO GND.

15173-002

Figure 2. Pin Configuration

Table 4. Pin Function Descriptions

Pin No.	Mnemonic	Description
1	IN1	Digital Control Input 1. The voltage applied to this pin controls the gate of the MEMS switch, RF1 to RFC. If IN1 is low, RF1 to RFC is open (off). If IN1 is high, connect RF1 to RFC (on).
2	IN2	Digital Control Input 2. The voltage applied to this pin controls the gate of the MEMS switch, RF2 to RFC. If IN2 is low, RF2 to RFC is open (off). If IN2 is high, connect RF2 to RFC (on).
3	IN3	Digital Control Input 3. The voltage applied to this pin controls the gate of the MEMS switch, RF3 to RFC. If IN3 is low, RF3 to RFC is open (off). If IN3 is high, connect RF3 to RFC (on).
4	IN4	Digital Control Input 4. The voltage applied to this pin controls the gate of the MEMS switch, RF4 to RFC. If IN4 is low, RF4 to RFC is open (off). If IN4 is high, connect RF4 to RFC (on).
5, 6, 8, 9, 11, 13, 14, 16, 17, 19, 21, 22	GND	Ground Connection.
7	EXTD_EN	External Voltage Drive Enable. In normal operation, set EXTD_EN low to enable the built in 11.5 MHz oscillator to enable the internal driver IC voltage boost circuitry. Setting EXTD_EN high disables the internal 11.5 MHz oscillator and driver boost circuitry. Disabling the internal oscillator eliminates the associated 11.5 MHz noise feedthrough into the switch. With the oscillator disabled, the switch can still be controlled via the logic interface pins (IN1 to IN4) but the $V_{CP}$ pin must be driven with 80V dc from an external voltage supply.
10	RF4	RF4 Port. This pin can be an input or an output. If unused, the pin must be connected to GND.
12	RF3	RF3 Port. This pin can be an input or an output. If unused, the pin must be connected to GND.
15	RFC	Common RF Port. This pin can be an input or an output.
18	RF2	RF2 Port. This pin can be an input or an output. If unused, the pin must be connected to GND.
20	RF1	RF1 Port. This pin can be an input or an output. If unused, the pin must be connected to GND.
23	$V_{DD}$	Positive Power Supply Input. For the recommend input voltage for this chip, see the Specifications section. Then, boost up this voltage internally to generate the voltage required to turn on the MEMS switch.
24	$V_{CP}$	Charge Pump Capacitor Terminal. The recommended shunt capacitor to ground value is 47 pF. If Pin 7 is high, an 80V dc drive voltage must be input into $V_{CP}$ to drive the switches.
	EP1	Exposed Pad 1. EP1 is internally connected to EP2 and must be connected to GND.
	EP2	Exposed Pad 2. EP2 is internally connected to EP1 and must be connected to GND.



# TYPICAL PERFORMANCE CHARACTERISTICS

For Figure 12, Figure 13, and Figure 14, T50 refers to the number of cycles for 50% of the population to fail.

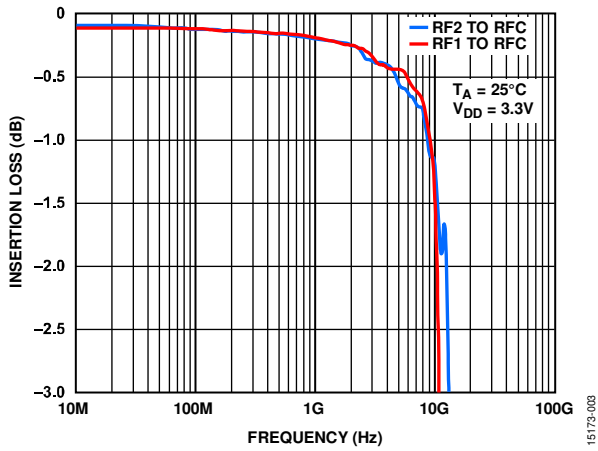

Figure 3. Insertion Loss vs. Frequency ( $V_{DD} = 3.3 V$ )

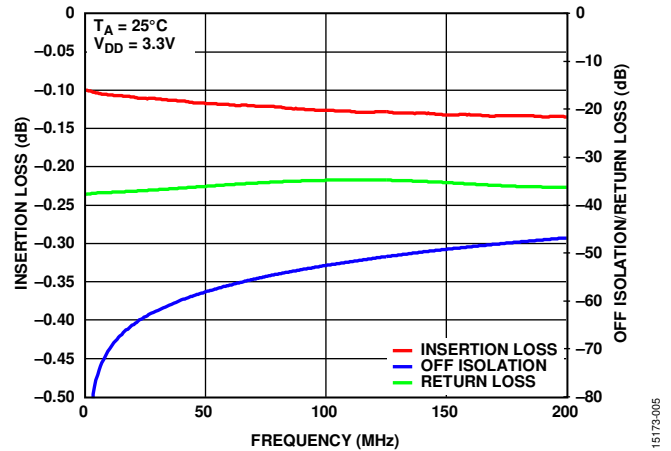

Figure 6. Low Frequency Insertion Loss and Off Isolation/Return Loss vs. Frequency ( $V_{DD} = 3.3 V$ , RF1 to RFC)

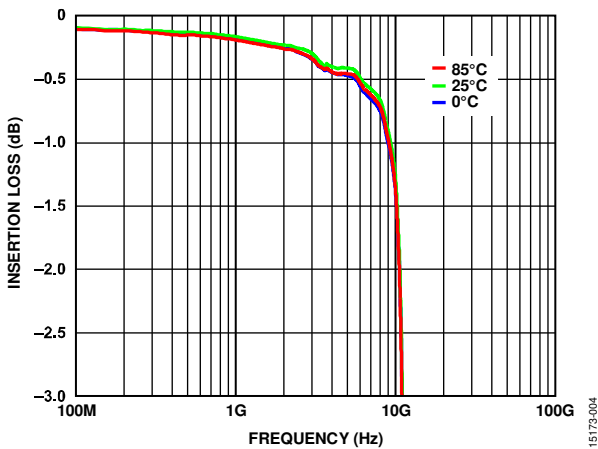

Figure 4. Insertion Loss vs. Frequency over Temperature ( $V_{DD} = 3.3 V$ , RF1 to RFC)

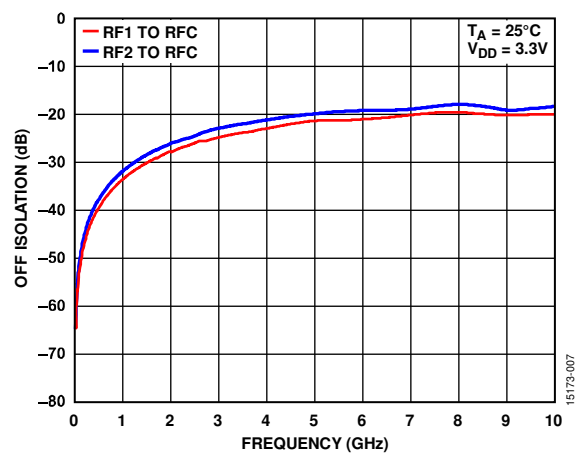

Figure 7. Off Isolation vs. Frequency ( $V_{DD} = 3.3 V$ )

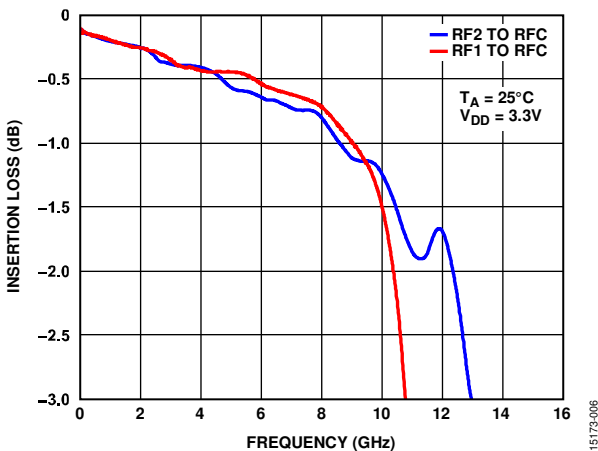

Figure 5. Insertion Loss vs. Frequency Linear Scale ( $V_{DD} = 3.3 V$ )

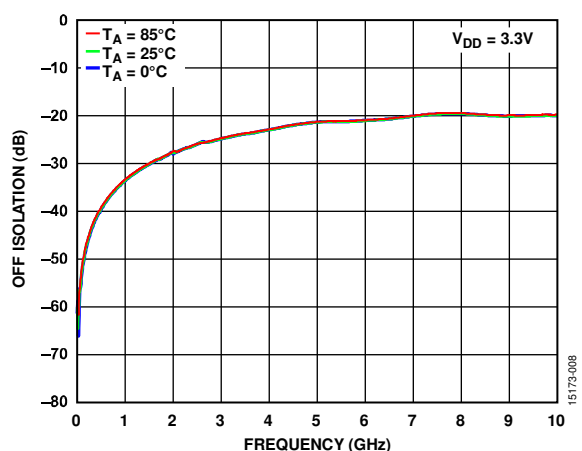

Figure 8. Off Isolation vs. Frequency over Temperature ( $V_{DD} = 3.3 V$ , RF1 to RFC)

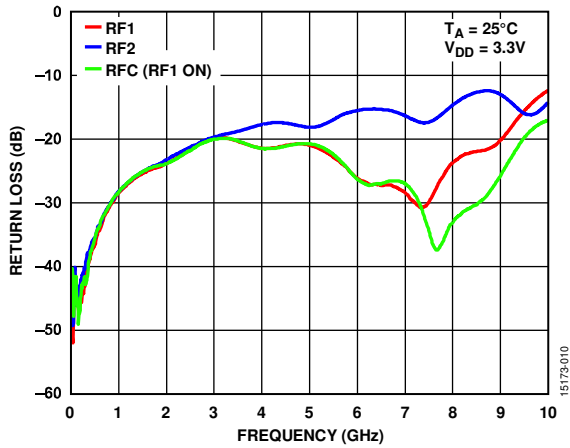

Figure 9. Return Loss vs. Frequency ( $V_{DD} = 3.3 V$ )

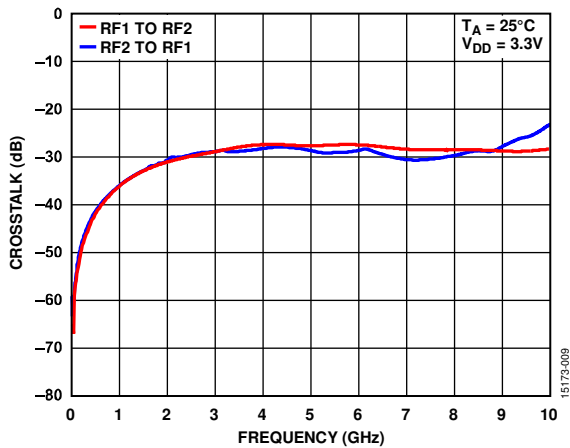

Figure 10. Crosstalk vs. Frequency ( $V_{DD} = 3.3 V$ )

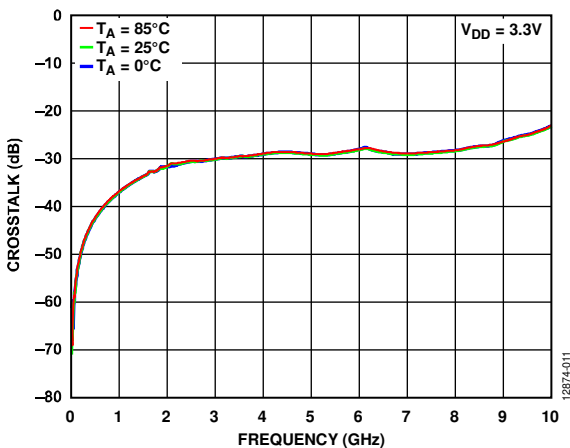

Figure 11. Crosstalk vs. Frequency over Temperature ( $V_{DD} = 3.3 V$ , RF2 to RF1)

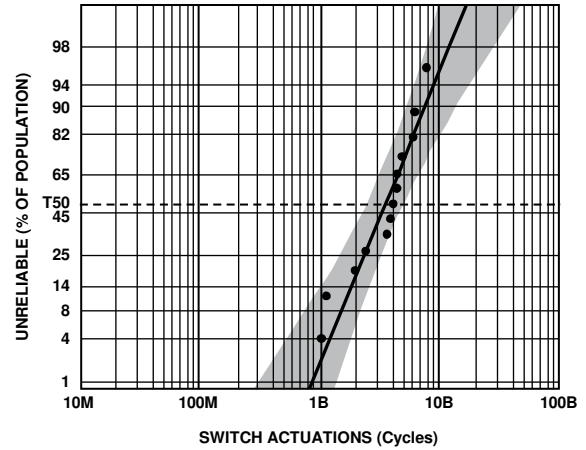

Figure 12. Log Normal Failure Probability with 95% Confidence Interval (CI) Indicated for Hot Switching a 10 dBm Continuous Wave (CW) Terminated into  $50 \Omega$ ,  $T_A = 25^\circ C$ ,  $V_{DD} = 3.3 V$

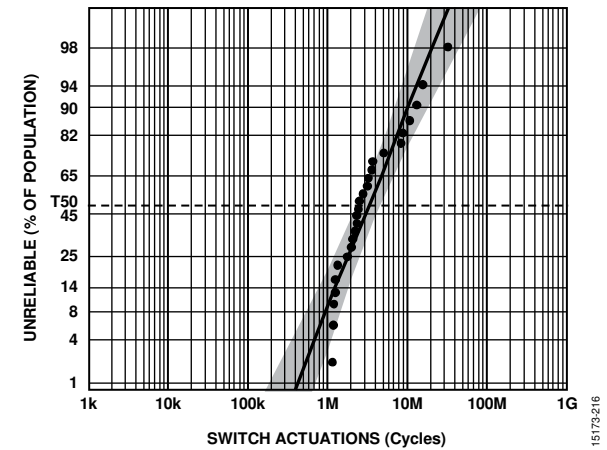

Figure 13. Log Normal Failure Probability with 95% CI Indicated for Hot Switching a 15 dBm CW Terminated into  $50 \Omega$ ,  $T_A = 25^\circ C$ ,  $V_{DD} = 3.3 V$

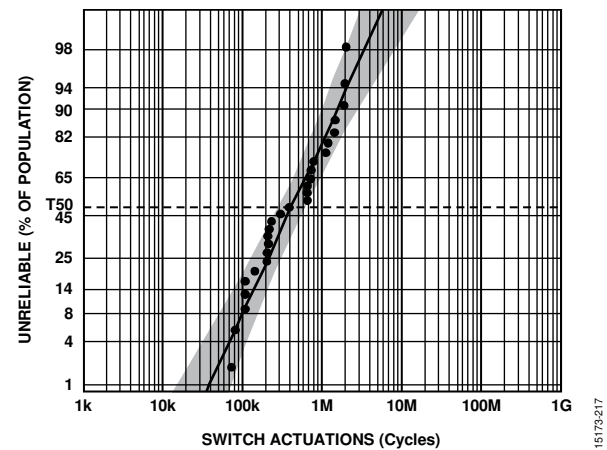

Figure 14. Log Normal Failure Probability with 95% CI Indicated for Hot Switching a 20 dBm CW Terminated into  $50 \Omega$ ,  $T_A = 25^\circ C$ ,  $V_{DD} = 3.3 V$

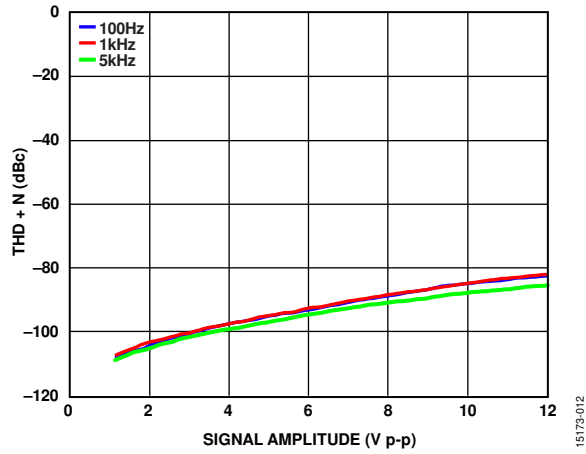

Figure 15. Total Harmonic Distortion Plus Noise (THD + N) vs. Signal Amplitude ( $V_{DD} = 3.3\text{ V}$ ,  $R_{LOAD} = 300\ \Omega$ ,  $T_A = 25^\circ\text{C}$ )

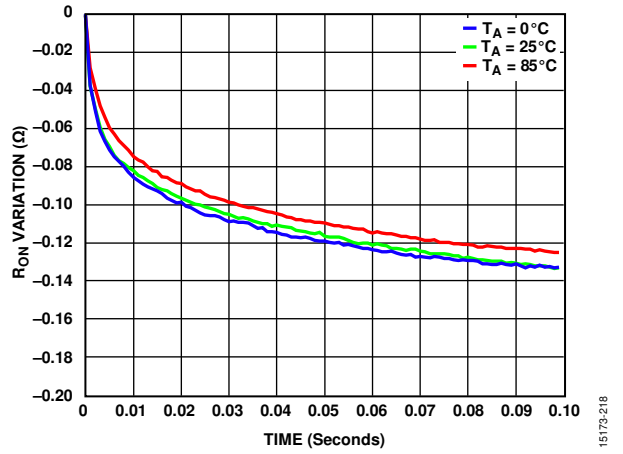

Figure 17.  $R_{ON}$  Variation vs. Time (1 ms to 100 ms) over Temperature ( $V_{DD} = 3.3\text{ V}$ , RF2 to RFC)

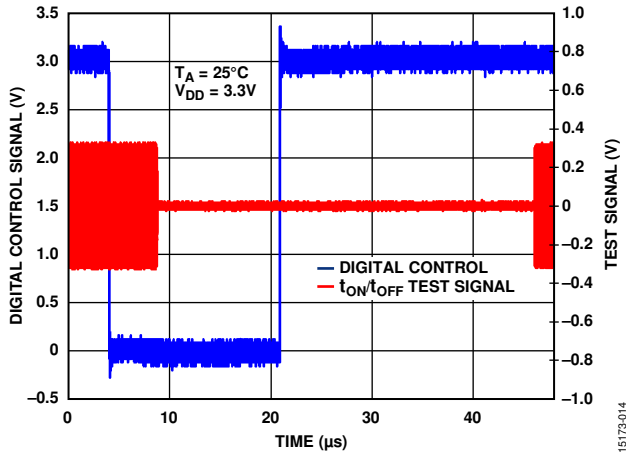

Figure 16. Digital Control Signal and Test Signal vs. Time ( $V_{DD} = 3.3\text{ V}$ )

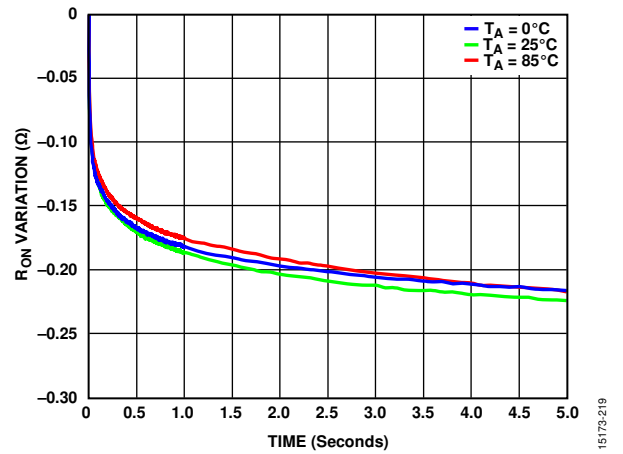

Figure 18.  $R_{ON}$  Variation vs. Time (1 ms to 5 sec) over Temperature ( $V_{DD} = 3.3\text{ V}$ , RF2 to RFC)

TEST CIRCUITS

Test circuits applicable to all channels, and additional pins omitted for clarity.

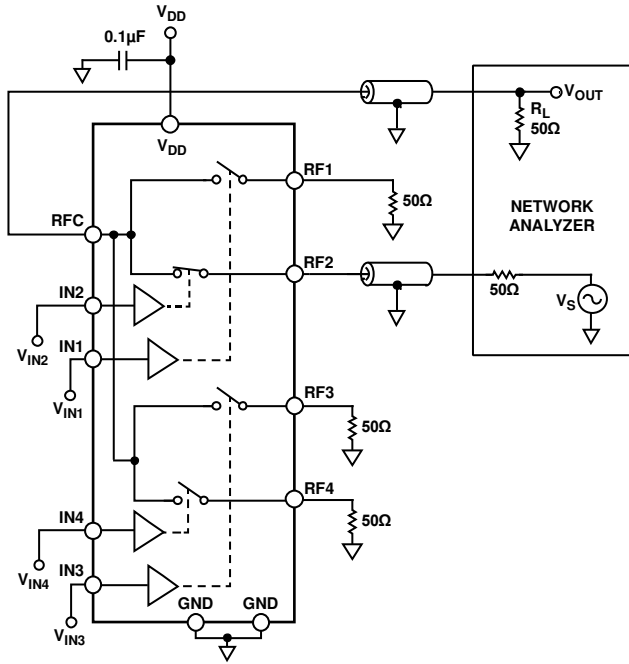

Figure 19. Insertion Loss/Return Loss

15173-015

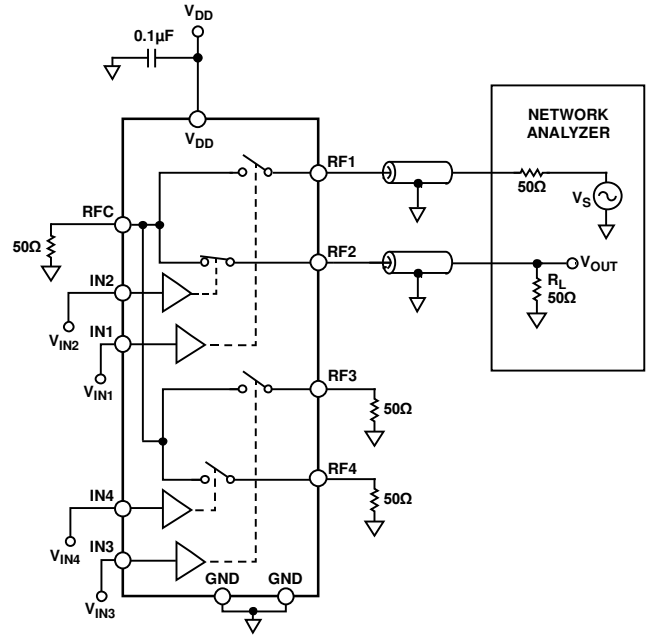

Figure 21. Crosstalk

15173-017

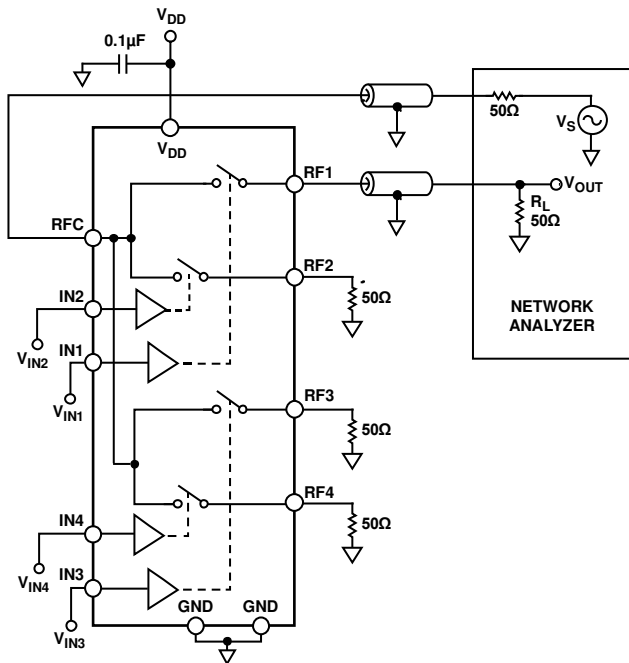

Figure 20. Isolation

15173-016

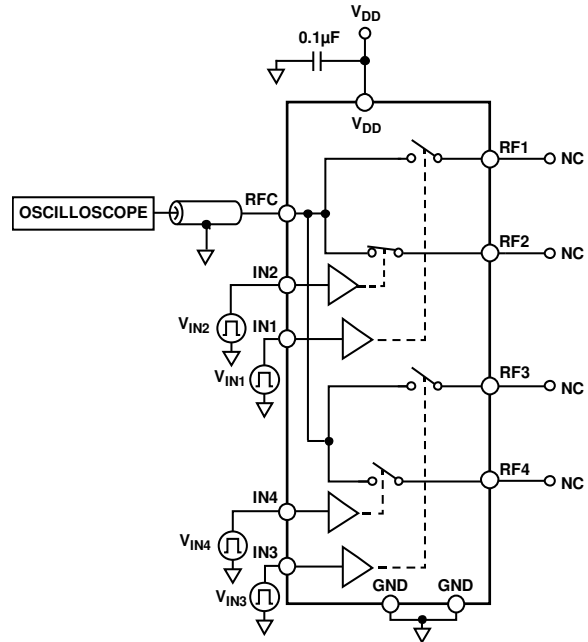

Figure 22. Video Feedthrough

15173-018

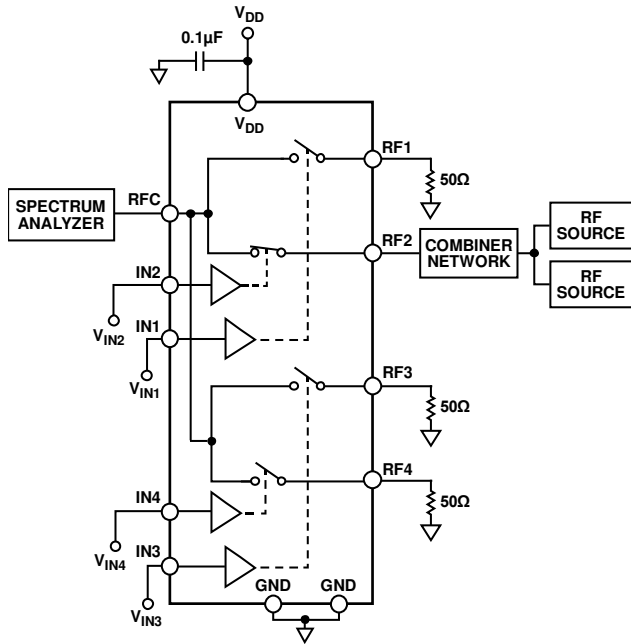

Figure 23. IIP2 and IIP3

15173-019

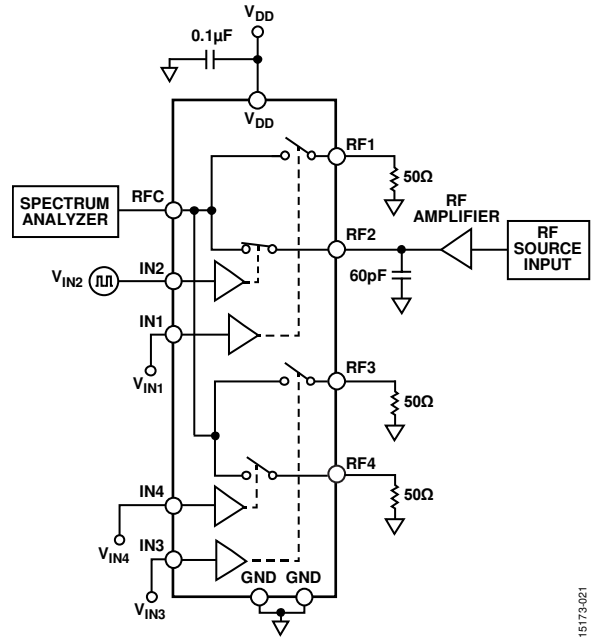

Figure 25. Hot Switching Evaluation Setup, 2 GHz RF Source, 50% Duty Cycle, 5 kHz Switching Actuation Speed

15173-021

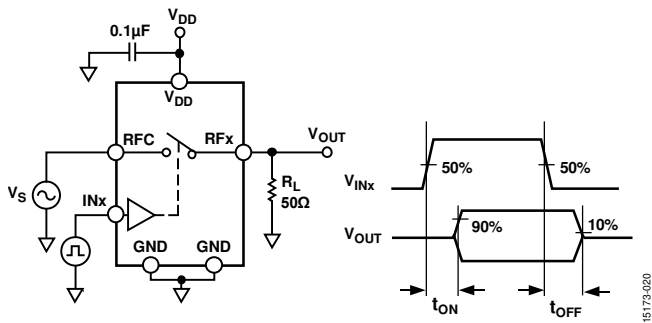

Figure 24. Switch Timing,  $t_{ON}$  and  $t_{OFF}$

15173-020

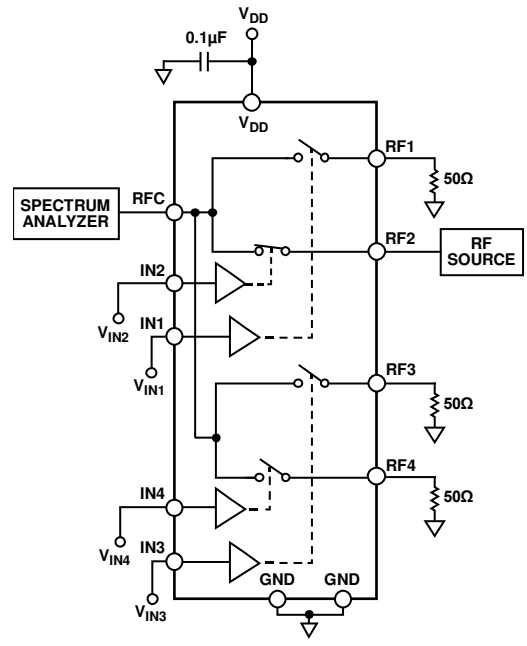

Figure 26. Second and Third Harmonics, RF Power

15173-022

## TERMINOLOGY

### Insertion Loss (IL)

IL is the amount of signal attenuation between the input and output ports of the switch when the switch is in the on state. Expressed in decibels, ensure that insertion loss is as small as possible for maximum power transfer.

An example calculation of insertion loss based on the setup in Figure 19 is as follows:

$$IL \text{ (dB)} = -20\log_{10}|S_{RF2RFC}|$$

where  $S_{RF2RFC}$  is the transmission coefficient measured from RF2 to RFC with RF2 in the on position. All unused switches are in the off position and terminated in a purely resistive load of 50  $\Omega$ .

### Isolation ( $I_{SO}$ )

$I_{SO}$  is the amount of signal attenuation between the input and output ports of the switch when the switch is in the off state. Expressed in decibels, ensure that isolation is as large as possible.

An example calculation of isolation based on the setup in Figure 20 is as follows:

$$I_{SO} \text{ (dB)} = -20\log_{10}|S_{RFCRF1}|$$

where  $S_{RFCRF1}$  is the transmission coefficient measured from RFC to RF1 with RF1 in the off position. All unused switches are in the off position and terminated in a purely resistive load of 50  $\Omega$ .

### Crosstalk ( $C_{TK}$ )

$C_{TK}$  is a measure of unwanted signals coupled through from one channel to another because of parasitic capacitance.

An example calculation of crosstalk based on the setup in Figure 21 is as follows:

$$C_{TK} \text{ (dB)} = -20\log_{10}|S_{RF1RF2}|$$

where  $S_{RF1RF2}$  is the transmission coefficient measured from RF1 to RF2 with RF1 in the off position and RF2 in the on position. All unused switches are in the off position and terminated in a purely resistive load of 50  $\Omega$ .

### Return Loss (RL)

RL is the magnitude of the reflection coefficient expressed in decibels, and the amount of reflected signal relative to the incident signal.

An example calculation of return loss based on the setup in Figure 19 is as follows:

$$RL \text{ (dB)} = -20\log_{10}|S_{11}|$$

where  $S_{11}$  is the reflection coefficient of the port under test.

### Third-Order Intermodulation Intercept (IIP3)

IIP3 is the intersection point of the fundamental  $P_{OUT}$  vs.  $P_{IN}$  extrapolated line and the third-order intermodulation products extrapolated line of a two-tone test. IIP3 is a figure of merit that characterizes the switch linearity.

### Second-Order Intermodulation Intercept (IIP2)

IIP2 is the intersection point of the fundamental  $P_{OUT}$  vs.  $P_{IN}$  extrapolated line and the second-order intermodulation products extrapolated line of a two-tone test. IIP2 is a figure of merit that characterizes the switch linearity.

### Second Harmonic (HD2)

HD2 is the amplitude of the second harmonic, where, for a signal whose fundamental frequency is  $f$ , the second harmonic has a frequency of  $2f$ . This measurement is a single-tone test, expressed with reference to the carrier signal (dBc).

### Third Harmonic (HD3)

HD3 is the amplitude of the third harmonic, where, for a signal whose fundamental frequency is  $f$ , the third harmonic has a frequency of  $3f$ . This measurement is a single tone test, expressed with reference to the carrier signal (dBc).

### On Switching Time ( $t_{ON}$ )

$t_{ON}$  is the time it takes for the switch to turn on. It is measured from 50% of the control signal ( $INx$ ) to 90% of the on level. No power was applied through the switch during this test (cold switched). The switch was terminated into a 50  $\Omega$  load.

### Off Switching Time ( $t_{OFF}$ )

$t_{OFF}$  is the time it takes for the switch to turn off. It is measured from 50% of the control signal ( $INx$ ) to 10% of the on level. No power was applied through the switch during this test (cold switched). The switch was terminated into a 50  $\Omega$  load.

### Settling Time Rising Edge

The settling time rising edge is the time it takes for the power of an RF signal to settle within 0.05 dB of its final steady state value. The switch was terminated into a 50  $\Omega$  load.

### Settling Time Falling Edge

The settling time falling edge is the time it takes for the power of an RF signal to settle within 0.05 dB of its final steady state value. The switch was terminated into a 50  $\Omega$  load.

### Actuation Frequency

The actuation frequency refers to the speed at which the [ADGM1004](#) can be switched on and off. Actuation frequency is dependent on both settling times and on/off switching times.

### Power-Up Time

The power-up time is a measure of the time required for the device to power up and start to pass 90% of an RF input signal after  $V_{DD}$  has reached 95%.

### Video Feedthrough

Video feedthrough is a measure of the spurious signals present at the RFX ports of the switch when the control voltage is switched from high to low or from low to high without an RF signal present.

### Internal Oscillator Frequency

The internal oscillator frequency is the value of the on-board oscillator that drives the gate control chip of the [ADGM1004](#).

**Internal Oscillator Feedthrough**

The internal oscillator feedthrough is the amount of internal oscillator signal that feeds through to the RFx and RFC pins of the switch. This signal appears as a noise spur on the RFx and RFC pins of the switch at the frequency the oscillator is operating at and harmonics thereof.

**On Resistance ( $R_{ON}$ )**

$R_{ON}$  is the resistance of a switch in the closed/on state measured between the package pins. Measure resistance in 4-wire mode to null out any cabling or PCB series resistances.

**On Resistance Variation**

On resistance variation is the variation in the on resistance of the switch over the specified criteria in Table 1.

**Continuously On Lifetime**

The continuously on lifetime parameter measures how long the switch is left in a continuously on state. If the switch is left in the on position for an extended period, it affects the turn off mechanism of the device.

**Actuation Lifetime**

Actuation lifetime is the number of consecutive open/close/open cycles that can complete without the on resistance exceeding a specified limit and no occurrence of failures to open (FTO) or failures to close (FTC).

**Cold Switching**

Cold switching operates the switch in a mode so that no voltage differential exists between source and drain when the switch is closed and/or no current is flowing source to drain when the switch opens. All switches have longer lives when cold switched.

**Hot Switching**

Hot switching is operating the switch in a mode where a voltage differential exists between source and drain when the switch is closed and/or current is flowing RFx to RFC when the switch is opened. Hot switching results in a reduced switch life, depending on the magnitude of the open circuit voltage between the source and the drain.

**Input High Voltage ( $V_{INH}$ )**

$V_{INH}$  is the minimum input voltage for Logic 1.

**Input Low Voltage ( $V_{INL}$ )**

$V_{INL}$  is the maximum input voltage for Logic 0.

## THEORY OF OPERATION

The **ADGM1004** is a wideband SP4T switch fabricated using Analog Devices, Inc., MEMS switch technology. This technology enables high power, low loss, low distortion gigahertz switches to be realized for demanding RF applications.

A key strength of the MEMS switch is that it simultaneously brings together best-in-class high frequency RF performance and 0 Hz/dc precision performance. This combination coupled with superior reliability and a tiny surface mountable form factor make the MEMS switch the ideal switching solution for all RF and precision signal instrumentation needs.

Figure 27 shows a stylized cross section graphic of the switch with dimensions. The switch is an electrostatically actuated cantilever beam connected in a 3-terminal configuration. Functionally, it is analogous to a field effect transistor (FET); the terminals can be used as a source, gate, and drain.

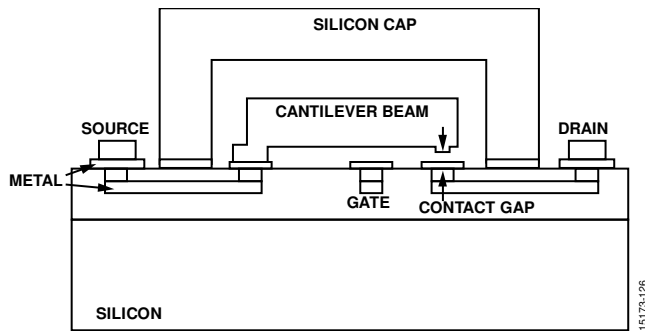

Figure 27. Cross Section of the MEMS Switch Design Showing the Cantilever Switch Beam (Not to Scale)

When a dc actuation voltage is applied between the gate electrode and the source (the switch beam), an electrostatic force is generated, resulting in attracting the beam toward the substrate. A separate on-board charge pump IC generates the bias voltage; 80 V is used for actuation.

Table 5. Truth Table

IN1	IN2	IN3	IN4	RF1 to RFC	RF2 to RFC	RF3 to RFC	RF4 to RFC
0	0	0	0	Off	Off	Off	Off
0	0	0	1	Off	Off	Off	On
0	0	1	0	Off	Off	On	Off
0	0	1	1	Off	Off	On	On
0	1	0	0	Off	On	Off	Off
0	1	0	1	Off	On	Off	On
0	1	1	0	Off	On	On	Off
0	1	1	1	Off	On	On	On
1	0	0	0	On	Off	Off	Off
1	0	0	1	On	Off	Off	On
1	0	1	0	On	Off	On	Off
1	0	1	1	On	Off	On	On
1	1	0	0	On	On	Off	Off
1	1	0	1	On	On	Off	On
1	1	1	0	On	On	On	Off
1	1	1	1	On	On	On	On

When the bias voltage between the gate and the source exceeds the threshold voltage of the switch,  $V_{TH}$ , the contacts on the beam touch the drain, which completes the circuit between the source and the drain and turns the switch on. When the bias voltage is removed, that is, 0 V on the gate electrode, the beam acts as a spring generating a sufficient restoring force to open the connection between the source and the drain, thus breaking the circuit and turning the switch off.

The silicon cap covering the switch die is shown in Figure 27. This cap hermetically seals the switch, which improves reliability. The switch contacts do not suffer from dry switching or low power switching lifetime degradation.

## DIGITAL INTERFACE

The **ADGM1004** is controlled via a parallel interface. Standard CMOS/LVTTL signals applied through this interface control the actuation or release of all of the switch channels of the **ADGM1004**. Gate signals applied are boosted to provide the required voltages needed to actuate the MEMS switch.

Pin 1 to Pin 4 (IN1 to IN4) control the switching functions of the **ADGM1004**. When a Logic 1 is applied to one of these pins, the gate of the corresponding switch is activated, and the switch turns on. Conversely, when a Logic 0 is applied to any of these pins, the switch turns off. Note that it is possible to connect more than one RFx input to RFC at a time. The truth table for the **ADGM1004** is given in Table 5.



**INTERNAL OSCILLATOR/EXTD\_EN**

The ADGM1004 has an internal oscillator running at a nominal 11.5 MHz. This oscillator drives the charge pump circuitry that provides the actuation voltage for each of the switch gate electrodes. Although this oscillator is very low power, the 11.5 MHz signal is coupled to the switch and can be considered a noise spur on the switch channels. The magnitude of this feedthrough noise spur is specified in Table 1 and is typically -115 dBm when one switch is on. When all four switches are simultaneously on, the feedthrough goes up to -94 dBm.  $V_{DD}$  level and temperature changes affect the frequency of the noise spur. For the maximum and minimum frequency range over temperature and voltage supply range, see Table 1.

Setting the EXTD\_EN pin high disables the internal oscillator and driver boost circuitry. With the driver boost circuitry disabled, applying an external 80 V dc to the  $V_{CP}$  pin enables the switch to be driven via the digital interface, as outlined in Table 4. Disabling the boost circuitry and driving it with an external 80 V dc source completely eliminates oscillator feedthrough that can be an issue in some applications.

**TYPICAL OPERATING CIRCUIT**

Figure 28 shows the typical operating circuit for the ADGM1004 as used in the EVAL-ADGM1004EBZ evaluation board. A 47 pF external capacitor is required on the  $V_{CP}$  pin; this capacitor is a holding capacitor for the 80 V dc gate drive voltage. Because the device incorporates the boost circuitry required to generate the 80 V dc, the boost circuitry results in an overall saving in the number of external components required, and therefore reduces board space needed to use the device.

In the circuit shown in Figure 28,  $V_{DD}$  is connected to 3.3 V. EP1 connects to EP2 internally. Typically, one large GND pad on the PCB is used to short together EP1 and EP2. Figure 28 shows the ADGM1004 configured to use the internal oscillator as the reference clock to the driver IC control circuit. Alternatively, set Pin 7 high and apply 80 V dc directly to Pin 24 to disable the internal oscillator and eliminate all oscillator feedthrough. The switches can then be controlled as normal via the logic control interface, Pin 1 to Pin 4.

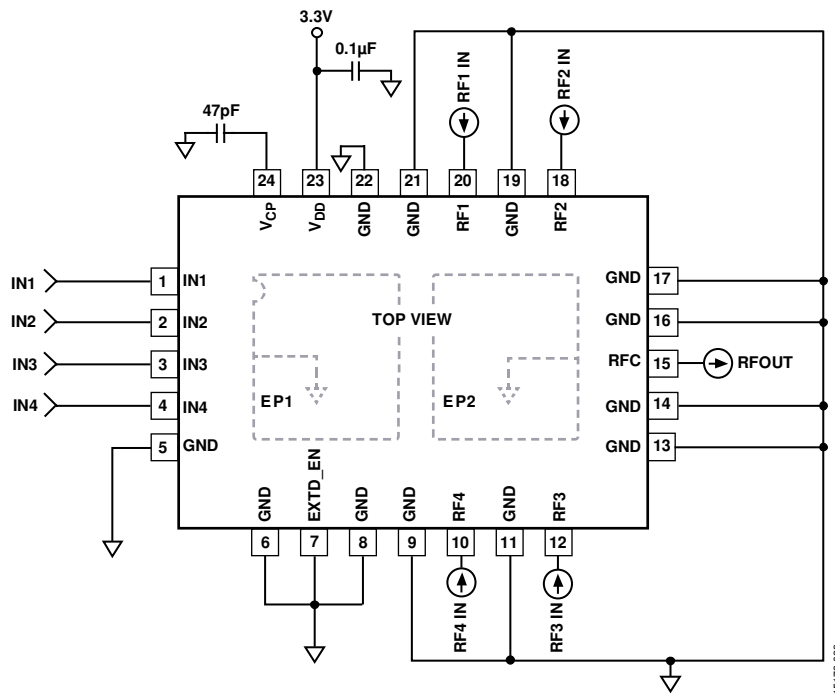

Figure 28. Typical Operating Circuit

## APPLICATIONS INFORMATION

### FLOATING NODE AVOIDANCE

As outlined in the Theory of Operation section, to actuate the switch, 80 V dc is generated internally in the **ADGM1004** device and applied to a gate electrode, which creates the electrostatic attraction force that actuates the switch. Without an external impedance to a dc voltage reference, charges can increase on the switch terminals, causing voltages to float to unknown levels, which can lead to unreliable actuation behavior with potential to damage the switch. To ensure correct and reliable switch actuation, ensure that all switch nodes have a dc voltage reference such as a connection to another active component with an internal voltage reference or an impedance to ground. Figure 29 to Figure 32 show examples of four cases to avoid where floating nodes can occur when using the switch. These include the following:

- RFX pins must not be open circuit
- A series capacitor connected directly to the switch can result in a floating node condition
- Connecting the RFX pin of two switches directly together or RFC to RFX can result in a floating node condition

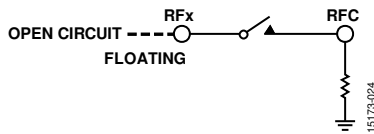

Figure 29. RFX Left Open Circuit

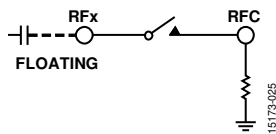

Figure 30. Series Capacitor Connected Directly to the Switch Can Result in a Floating Node Condition

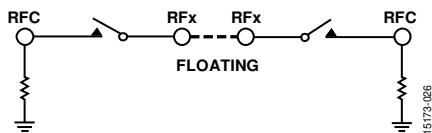

Figure 31. Connecting the RFX Pin of Two Switches Directly Together Can Result in a Floating Node Condition

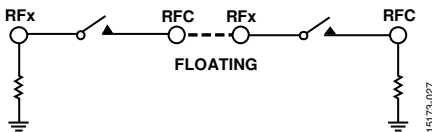

Figure 32. Connecting RFC to RFX Can Result in a Floating Node Condition

Providing a dc voltage reference to the switch ensures a correct gate to beam voltage differential to drive the switch and prevents unreliable actuation. In a typical application, a 50 Ω termination connected to the switch provides a constant dc voltage reference. Most amplifiers and other active devices also have an internal dc voltage reference; therefore, when they are connected directly to the switch, they provide a dc voltage reference and avoid any floating node issues. If there is no inherent dc voltage reference in the application circuit, a 10 MΩ shunt resistor or inductor on the source (RFX) pin of the MEMS switch must be added to provide a voltage reference. The addition of external shunt resistors increases the leakage above the specification listed in Table 1. Figure 33 shows this type of voltage reference configuration.

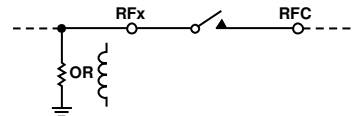

Figure 33. Switch Configuration Providing a Voltage Reference

Figure 34 and Figure 35 illustrate typical cascaded switch use cases and the corresponding schemes to mitigate floating node risks. The path between the two switches needs a voltage reference to ground; otherwise, the path can float to an unknown voltage and subsequently cause unreliable actuations, possibly leading to hot switching events or switches remaining in the on state. Use 10 MΩ shunt resistors to provide the voltage references.

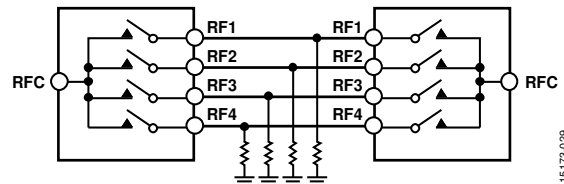

Figure 34. Two **ADGM1004** Devices Connected Together with Shunt Resistors to Mitigate Floating Nodes

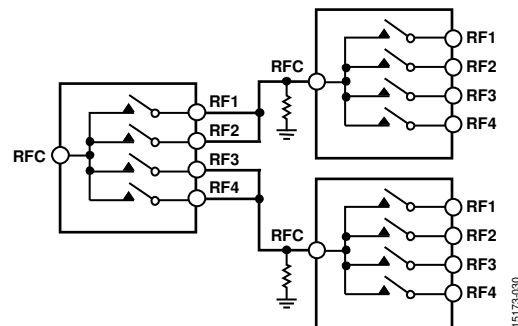

Figure 35. Three **ADGM1004** Devices Connected Together with Shunt Resistors to Mitigate Floating Nodes

**CONTINUOUSLY ON LIFETIME**

If the switch channel is in the on state for extended periods of time (more than seven years), the switch can fail to turn off due to mechanical degradation effects. The continuously on lifetime feature is duty cycle dependent; in low duty cycle uses cases (for example, 10% on, 90% off), there is no lifetime degradation.

The ADGM1004 has a continuous on lifetime specification of 7.2 years (typical) at 50°C; see Table 1.

Figure 36 shows the extrapolated failure time of 31 switches where all of them were held in the on state continuously at 50°C until they failed to open. The lifetime is affected by temperature. As the temperature increases above 50°C, the continuously on lifetime degrades significantly. However, for lower temperatures, the lifetime improves.

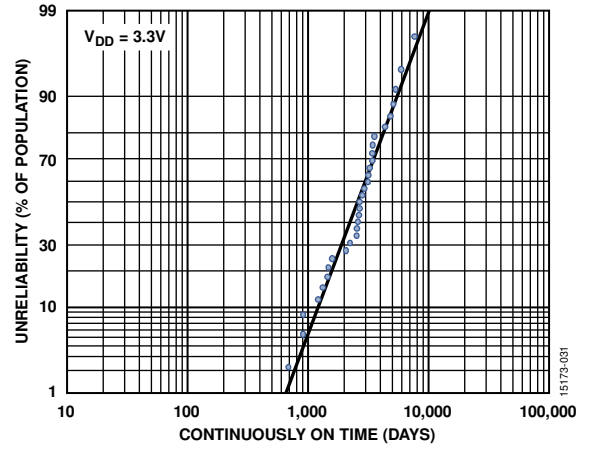

Figure 36. Continuously On Lifetime,  $V_{DD} = 3.3\text{ V}$ , 50°C, Sample Size = 31 Devices

## SUGGESTED APPLICATION CIRCUITS

### SWITCHABLE RF ATTENUATOR

RF attenuator networks are commonly used in RF instrumentation equipment such as vector network analyzers, spectrum analyzers, and signal generators. Routing RF signals through an attenuator can enable the equipment to accept higher power signals and, therefore, increase the dynamic range of the instrument. In RF attenuation applications like the vector network analyzers, spectrum analyzers, and signal generators, maintaining the bandwidth of the signal after it passes through the network is critical. Any degradation of the signal reduces the performance of the equipment. Therefore, the RF characteristics of the switches used for routing are an integral part of the quality of an attenuator network.

The ADGM1004 MEMS switch with low flat insertion loss, wide RF bandwidth, and high reliability is suited for use as a switchable RF attenuator. The ADGM1004, as an SP4T switch, also brings added flexibility. Figure 37 shows an example attenuation network configuration using two ADGM1004 switches and three different attenuators. The fourth channel of the switches is used as a nonattenuated route in Figure 37.

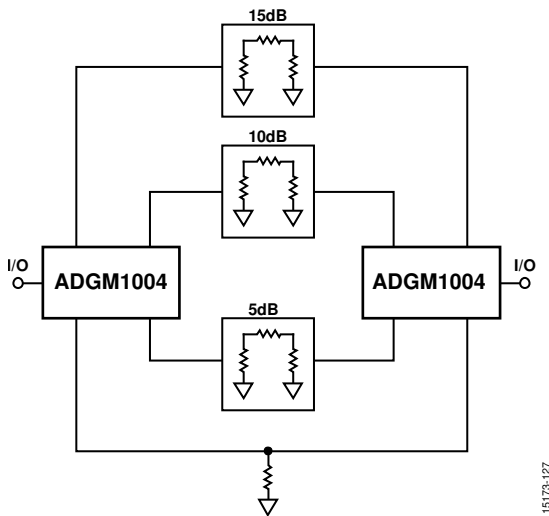

Figure 37. Switching RF Attenuators Using ADGM1004 MEMS Switches

### RECONFIGURABLE RF FILTER

A reconfigurable RF filter is advantageous in many RF front-end applications. A reconfigurable RF filter provides more saved space. As space becomes more constrained in applications, the option to have an economical reconfigurable RF filter instead of individual frequency dependent filters is attractive.

The ADGM1004, with its low flat insertion loss, wide RF bandwidth, low parasitic, low capacitance, and high linearity, is needed to turn on the lump components (capacitor, inductor), which make the MEMS switch suited for reconfigurable filter application.

In applications such as wireless communications or mobile radios, the number of bands and/or modes constantly increases. A reconfigurable RF filter allows more bands/modes to be covered using the same components.

Figure 38 shows an example of a reconfigurable band-pass filter. The topology shown is of a generalized two-section, inductively coupled, single-ended band-pass filter, nominally centered on 400 MHz ultrahigh frequency (UHF) band. The MEMS switches are positioned in series with each of the shunt inductors.

The function of the switches includes or omits a shunt inductor from the circuit. Changing the shunt inductor value affects the bandwidth and center frequency of the filter. Using inductance values from 15 nH to 30 nH significantly alters the bandwidth and center frequency, allowing the filter to dynamically configure to operate in the UHF or very high frequency (VHF) bands while preserving the 50 Ω match on the input and output ports. The low  $R_{ON}$  value and wide bandwidth of the MEMS switch makes it an ideal choice for this application. The low  $R_{ON}$  reduces the negative effect a series resistance has on the quality factor of the shunt inductor. The large bandwidth enables higher frequency band-pass filters.

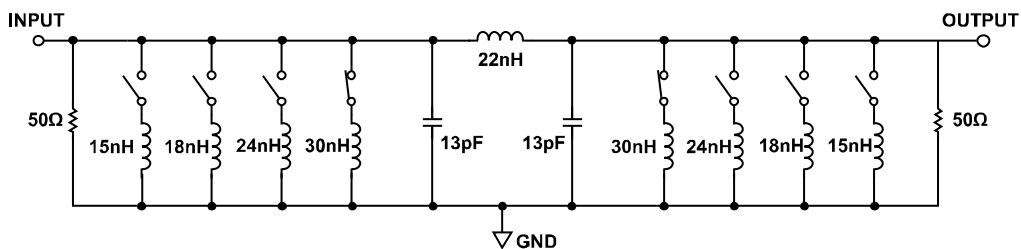

Figure 38. Reconfigurable Band-Pass Filter Achieved Using Two ADGM1004 MEMS Switches

## HANDLING GUIDELINES

### ELECTRICAL OVERSTRESS (EOS) PRECAUTIONS

A stored charge inadvertently conducted through the switches can result in immediate permanent damage to the ADGM1004. Therefore, observe the following precautions:

- Treat the ADGM1004 as a static sensitive device and observe all normal handling precautions, which include, working only on static dissipative surfaces, wearing wrist straps or other ESD control devices, and storing unused devices in conductive foam.
- Avoid connecting large capacitive terminations directly to the switch. A shunt capacitor can store a charge that can potentially give rise to hot switching events when the switch opens or closes, affecting the lifetime of the switch. Figure 39 shows where to avoid large capacitive terminations.

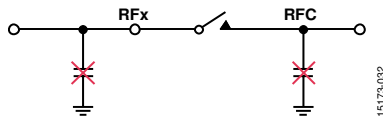

Figure 39. Avoid Connecting Large Capacitive Terminations Directly to the Switch

### DC VOLTAGE RANGE

The dc voltage range of the switch, the dc signal range the switch is specified to carry, is  $\pm 6$  V (see Table 1)

### MECHANICAL SHOCK PRECAUTIONS

The device passes an extensive mechanical shock qualification process. Table 6 shows a summary of the mechanical shock qualification tests used on the ADGM1004. These tests validate the robustness of the device to mechanical shocks.

Table 6. Mechanical Shock Qualification Summary

Parameter	Qualification
Random Drop	AEC-Q100 Test G5, five drops from 0.6 m
Vibration Testing	MIL-STD-883, M2007.3, Condition B, 20 Hz to 2000 Hz at 50 g
Group D Sub 4 MIL-STD-883, M5005	Mechanical shock, 1500 g, 0.5 ms; vibration 50 g sine sweep, 20 Hz to 2000 Hz; acceleration 30,000 g

The device must be handled with care. As is the case with electromechanical relays, do not use the device if dropped and ensure that there are minimal mechanical shocks during the handling and manufacturing of the device.

Figure 40 shows examples of loose device handling situations that must be avoided due to mechanical shock and ESD event risk.

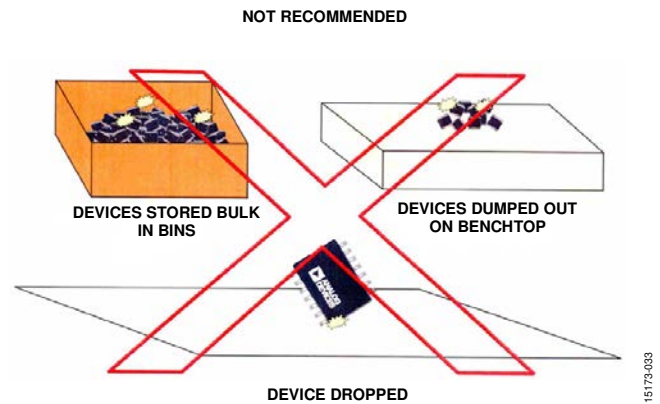

Figure 40. Device Handling Precautions

OUTLINE DIMENSIONS

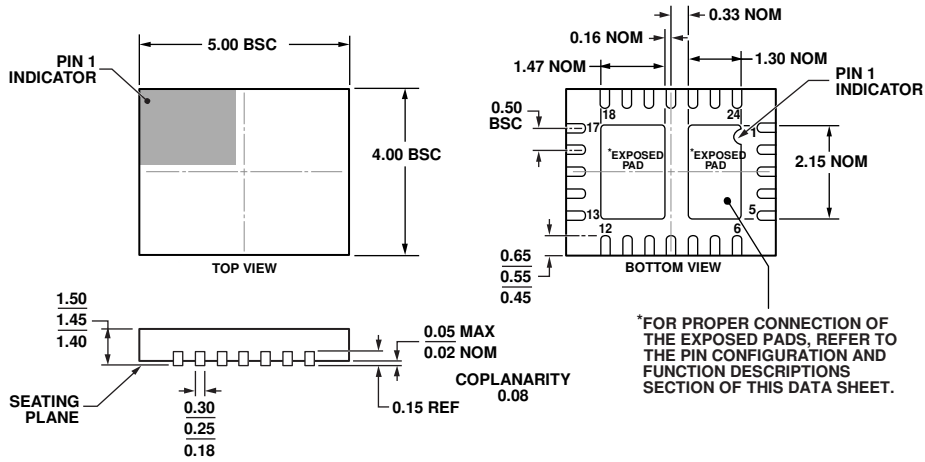

Figure 41. 24-Lead Lead Frame Chip Scale Package [LFCSP]  
 5 mm x 4 mm Body, and 1.45 mm Package Height  
 (CP-24-4)

Dimensions shown in millimeters

ORDERING GUIDE

Model <sup>1</sup>	Temperature Range	Package Description	Package Option
ADGM1004JCPZ-R2	0°C to 85°C	24-Lead Lead Frame Chip Scale Package [LFCSP]	CP-24-4
ADGM1004JCPZ-RL7	0°C to 85°C	24-Lead Lead Frame Chip Scale Package [LFCSP]	CP-24-4
EVAL-ADGM1004EBZ		Evaluation Board	

<sup>1</sup> Z = RoHS Compliant Part.