



Chipsmall Limited consists of a professional team with an average of over 10 year of expertise in the distribution of electronic components. Based in Hongkong, we have already established firm and mutual-benefit business relationships with customers from,Europe,America and south Asia,supplying obsolete and hard-to-find components to meet their specific needs.

With the principle of "Quality Parts,Customers Priority,Honest Operation,and Considerate Service",our business mainly focus on the distribution of electronic components. Line cards we deal with include Microchip,ALPS,ROHM,Xilinx,Pulse,ON,Everlight and Freescale. Main products comprise IC,Modules,Potentiometer,IC Socket,Relay,Connector.Our parts cover such applications as commercial,industrial, and automotives areas.

We are looking forward to setting up business relationship with you and hope to provide you with the best service and solution. Let us make a better world for our industry!



Contact us

Tel: +86-755-8981 8866 Fax: +86-755-8427 6832

Email & Skype: info@chipsmall.com Web: www.chipsmall.com

Address: A1208, Overseas Decoration Building, #122 Zhenhua RD., Futian, Shenzhen, China



GENERAL DESCRIPTION

The ADIS16080/PCB is a simple evaluation board that provides convenient access to the ADIS16080 using a standard 2mm, 2x6, connector interface. These connectors can be accessed using a variety of cable options, including standard 1mm ribbon cables. The ADIS16080/PCB is designed to be evaluated in an existing digital platform (MCU, DSP, FPGA, PLD, etc) or as part of the ADISEVAL system. Four mounting holes (sized for 2-56 or 2mm screws) have been provided to secure the board during evaluation.

CIRCUIT DESCRIPTION

The schematic, layout and parts list for the ADIS16080/PCB can be found in Figure 1, Figure 2, and Table 1.

The ADIS16080's digitized outputs can be accessed using the 4-wire serial port interface (SPI) signals on J1: SCLK, CS, DOUT and DIN. For specific information on using the ADIS16080's SPI interface, refer to the ADIS16080 datasheet. Auxiliary functions, such as the two 12-bit ADC inputs, can be accessed using J2. C1 and C4 provide additional filtering for the two different power supply inputs (Vdrive and Vcc). The ADIS16080's reference voltage is filtered by C2.

Table 1 – ADIS16080/PCB Parts List

| Reference Designator | Part Description |
|----------------------|---------------------------------------|
| U1 | ADIS16080ACCZ |
| J1,J2 | Connector, 12-pin, dual row, 2mm |
| C1, C4 | Power supply filtering, not installed |
| C2 | Vref filtering, not installed |
| C3 | Bandwidth reduction, not installed |

SPECIAL NOTES ON HANDLING

Note that the ADIS16080/PCB is not reverse polarity protected. Reversing the power supply or applying inappropriate voltages to any pin (outside the Absolute Maximum Ratings in the ADIS16080 data sheet) may damage the ADIS16080/PCB.

Table 2 – Power Supply Levels

| | |
|--------|------------------|
| Vcc | +4.75V to +5.25V |
| Vdrive | +2.7V to +5.25V |

Rev. PrC

8/14/2006

Information furnished by Analog Devices is believed to be accurate and reliable. However, no responsibility is assumed by Analog Devices for its use, nor for any infringements of patents or other rights of third parties that may result from its use. Specifications subject to change without notice. No license is granted by implication or otherwise under any patent or patent rights of Analog Devices. Trademarks and registered trademarks are the property of their respective owners.

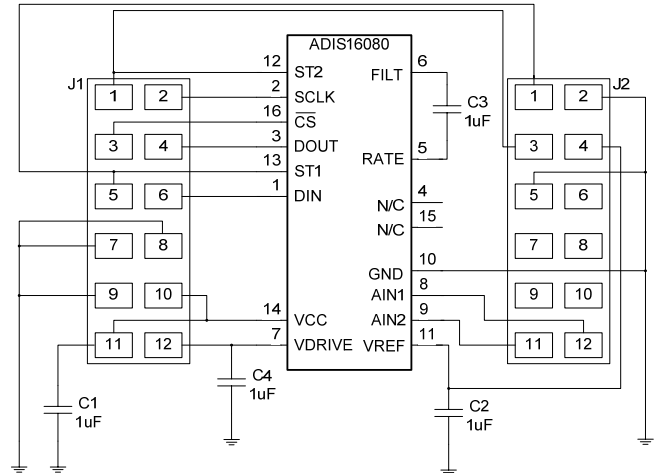

Figure 1 - ADIS16080/PCB Schematic

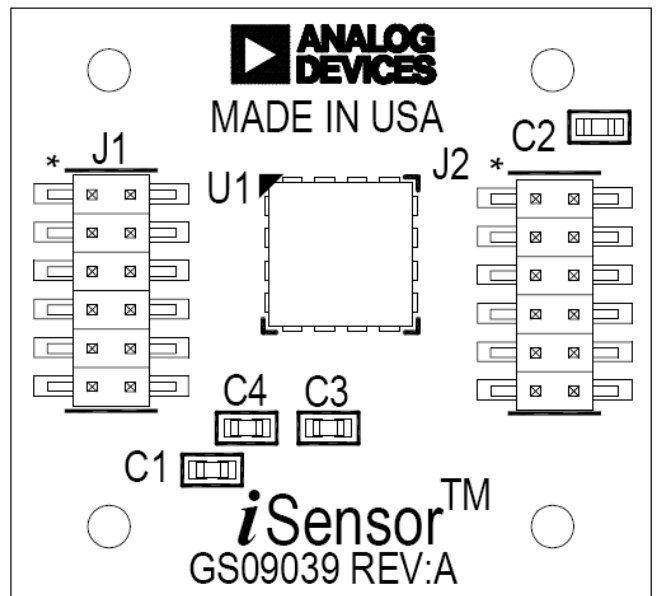

Figure 2 - ADIS16080/PCB Layout (Top View)

ORDERING GUIDE

| Model | Package Description |
|----------------|----------------------------------|
| ADIS16080/PCBZ | Evaluation Board, RoHS Compliant |
| ADISEVAL | iSensor™ PC Evaluation System |