



Chipsmall Limited consists of a professional team with an average of over 10 year of expertise in the distribution of electronic components. Based in Hongkong, we have already established firm and mutual-benefit business relationships with customers from,Europe,America and south Asia,supplying obsolete and hard-to-find components to meet their specific needs.

With the principle of "Quality Parts,Customers Priority,Honest Operation,and Considerate Service",our business mainly focus on the distribution of electronic components. Line cards we deal with include Microchip,ALPS,ROHM,Xilinx,Pulse,ON,Everlight and Freescale. Main products comprise IC,Modules,Potentiometer,IC Socket,Relay,Connector.Our parts cover such applications as commercial,industrial, and automotives areas.

We are looking forward to setting up business relationship with you and hope to provide you with the best service and solution. Let us make a better world for our industry!



## Contact us

Tel: +86-755-8981 8866 Fax: +86-755-8427 6832

Email & Skype: info@chipsmall.com Web: www.chipsmall.com

Address: A1208, Overseas Decoration Building, #122 Zhenhua RD., Futian, Shenzhen, China



## FEATURES

### Triaxial digital gyroscope

Measurement range:  $\pm 100^\circ/\text{sec}$  (minimum)

$8^\circ/\text{hr}$  (typical) in-run bias stability

$0.12^\circ/\sqrt{\text{hr}}$  (typical) angle random walk, x-axis

### Triaxial digital accelerometer, $\pm 5 g$ dynamic range

### Autonomous operation and data collection

No external configuration commands required

Fast start-up time

### Factory calibrated sensitivity, bias, and axial alignment

Calibration temperature range:  $0^\circ\text{C} \leq T_A \leq 70^\circ\text{C}$

### Serial peripheral interface (SPI) data communications

### Data ready signal for synchronizing data acquisition

### Embedded temperature sensor

### Programmable operation and control

Automatic and manual bias correction controls

Bartlett window finite impulse response (FIR) filter, variable number of taps

External sample clock options: direct

Single command self test

Single-supply operation: 3.15 V to 3.45 V

2000 g shock survivability

Operating temperature range:  $-25^\circ\text{C}$  to  $+85^\circ\text{C}$

## APPLICATIONS

Smart agriculture/construction machinery

Unmanned aerial vehicles (UAVs)/drones, and navigation  
and payload stabilization

Robotics

Factory/industrial automation personnel/asset tracking

## GENERAL DESCRIPTION

The ADIS16460 *iSensor*® device is a complete inertial system that includes a triaxial gyroscope and a triaxial accelerometer. Each sensor in the ADIS16460 combines industry leading *iMEMS*® technology with signal conditioning that optimizes dynamic performance. The factory calibration characterizes each sensor for sensitivity, bias, and alignment. As a result, each sensor has its own dynamic compensation formulas that provide accurate sensor measurements.

The ADIS16460 provides a simple, cost effective method for integrating accurate, multi-axis inertial sensing into industrial systems, especially when compared with the complexity and investment associated with discrete designs. All necessary motion testing and calibration are part of the production process at the factory, greatly reducing system integration time. Tight orthogonal alignment simplifies inertial frame alignment in navigation systems. The SPI and register structures provide a simple interface for data collection and configuration control.

The ADIS16460 is in an aluminum module package that is approximately 22.4 mm × 22.4 mm × 9 mm and has a 14-pin connector interface.

## FUNCTIONAL BLOCK DIAGRAM

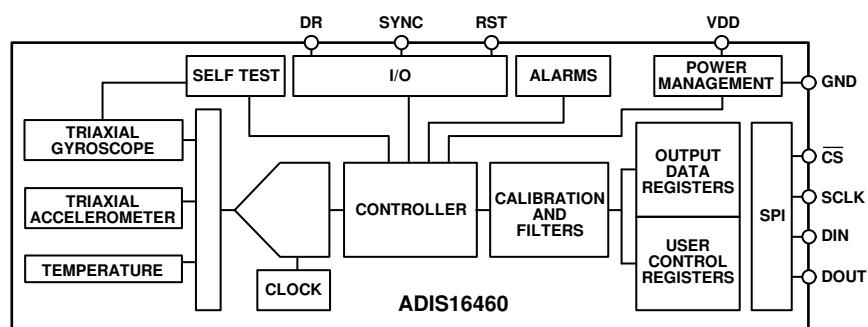

Figure 1.

Rev. A

[Document Feedback](#)

Information furnished by Analog Devices is believed to be accurate and reliable. However, no responsibility is assumed by Analog Devices for its use, nor for any infringements of patents or other rights of third parties that may result from its use. Specifications subject to change without notice. No license is granted by implication or otherwise under any patent or patent rights of Analog Devices. Trademarks and registered trademarks are the property of their respective owners.

One Technology Way, P.O. Box 9106, Norwood, MA 02062-9106, U.S.A.  
Tel: 781.329.4700 ©2016 Analog Devices, Inc. All rights reserved.  
[Technical Support](#) [www.analog.com](http://www.analog.com)

# ADIS16460\* PRODUCT PAGE QUICK LINKS

Last Content Update: 02/23/2017

---

## COMPARABLE PARTS

View a parametric search of comparable parts.

## EVALUATION KITS

- ADIS16IMU4 Breakout Board
- EVAL-ADIS Evaluation System
- EVAL-ADIS2 Evaluation System

## DOCUMENTATION

### Data Sheet

- ADIS16460: Compact, Precision, Six Degrees of Freedom Inertial Sensor Data Sheet

### User Guides

- Wiki Guide for PC-Based Evaluation of the ADIS16460

## REFERENCE MATERIALS

### Technical Articles

- Anticipating and Managing Critical Noise Sources in MEMS Gyros
- Designing For Low Noise Feedback Control With MemS Gyroscopes
- High Performance Inertial Sensing Solutions Enable Autonomous Machine Applications

## DESIGN RESOURCES

- ADIS16460 Material Declaration
- PCN-PDN Information
- Quality And Reliability
- Symbols and Footprints

## DISCUSSIONS

View all ADIS16460 EngineerZone Discussions.

## SAMPLE AND BUY

Visit the product page to see pricing options.

## TECHNICAL SUPPORT

Submit a technical question or find your regional support number.

## DOCUMENT FEEDBACK

Submit feedback for this data sheet.

## TABLE OF CONTENTS

Features .....	1	Global Commands .....	19
Applications .....	1	Software Reset .....	19
General Description .....	1	Flash Memory Test .....	19
Functional Block Diagram .....	1	Manual Flash Update .....	19
Revision History .....	2	Automated Self Test .....	19
Specifications .....	3	Input/Output Configuration .....	19
Timing Specifications .....	5	Data Ready (DR) Pin Configuration .....	19
Absolute Maximum Ratings .....	6	SYNC Pin Configuration .....	20
ESD Caution .....	6	Digital Processing Configuration .....	21
Pin Configuration and Function Descriptions .....	7	Gyroscopes/Accelerometers .....	21
Typical Performance Characteristics .....	8	Calibration .....	22
Theory of Operation .....	10	Gyroscopes .....	22
Reading Sensor Data .....	10	Accelerometers .....	22
Device Configuration .....	11	Restoring Factory Calibration .....	23
User Registers .....	12	Applications Information .....	24
Output Data Registers .....	13	Mounting Tips .....	24
Rotation .....	13	Power Supply Considerations .....	24
Accelerometers .....	15	Breakout Board .....	24
Internal Temperature .....	17	PC-Based Evaluation Tools .....	25
Product Identification .....	17	Outline Dimensions .....	26
Status/Error Flags .....	17	Ordering Guide .....	26
System Functions .....	19		

## REVISION HISTORY

### 8/2016—Rev. 0 to Rev. A

Changes to Features Section .....	1
Changes to Table 1 .....	3
Changes to $t_{NV}$ Parameter, Table 2 .....	5
Changed Acceleration (Shock) Parameter to Mechanical Shock Survival Parameter, Table 3 .....	6
Changes to Burst Read Function Section and Figure 21 .....	11
Change to Bit 7, Table 44 .....	19

### 1/2016—Revision 0: Initial Version

## SPECIFICATIONS

$T_A = 25^\circ\text{C}$ ,  $V_{DD} = 3.3\text{ V}$ , angular rate =  $0^\circ/\text{sec}$ ,  $\pm 1\text{ g}$ ,  $\text{MSC\_CTRL} = 0x00C1$ , unless otherwise noted.

Table 1.

Parameter	Test Conditions/Comments	Min	Typ	Max	Unit
<b>GYROSCOPES</b>					
Dynamic Range		$\pm 100$			$^\circ/\text{sec}$
Initial Sensitivity	16-bit data format <sup>1</sup>		0.005		$^\circ/\text{sec}/\text{LSB}$
	32-bit data format <sup>1</sup>		$7.63 \times 10^{-8}$		$^\circ/\text{sec}/\text{LSB}$
Repeatability <sup>2</sup>	$0^\circ\text{C} \leq T_A \leq 70^\circ\text{C}$			1	%
Sensitivity Temperature Coefficient	$0^\circ\text{C} \leq T_A \leq 70^\circ\text{C}$		$\pm 20$		ppm/ $^\circ\text{C}$
Misalignment	Axis to axis		$\pm 0.15$		Degrees
	Axis to frame (package)		$\pm 1$		Degrees
Nonlinearity	Best fit straight line		0.5		% of FS
Bias Repeatability <sup>2,3</sup>	$0^\circ\text{C} \leq T_A \leq 70^\circ\text{C}$ , $1\sigma$		0.5		$^\circ/\text{sec}$
In-Run Bias Stability	$1\sigma$		8		$^\circ/\text{hr}$
Angle Random Walk	$1\sigma$ , x-axis		0.12		$^\circ/\sqrt{\text{hr}}$
	$1\sigma$ , y-axis, z-axis		0.17		$^\circ/\sqrt{\text{hr}}$
Bias Temperature Coefficient	$0^\circ\text{C} \leq T_A \leq 70^\circ\text{C}$		$\pm 0.007$		$^\circ/\text{sec}/^\circ\text{C}$
Linear Acceleration Effect on Bias	Any axis, $1\sigma$		$\pm 0.01$		$^\circ/\text{sec}/\text{g}$
Vibration Rectification Error	20 Hz to 2000 Hz, 5 g rms		$\pm 0.0004$		$^\circ/\text{sec}/\text{g}^2$
Bias Supply Sensitivity	$3.15\text{ V} \leq V_{DD} \leq 3.45\text{ V}$		0.037		$^\circ/\text{sec}/\text{V}$
Output Noise	No filtering		0.075		$^\circ/\text{sec rms}$
Rate Noise Density	10 Hz to 40 Hz, no filtering		0.004		$^\circ/\text{sec}/\sqrt{\text{Hz rms}}$
-3 dB Bandwidth			375		Hz
Sensor Resonant Frequency			65		kHz
<b>ACCELEROMETERS</b>					
Dynamic Range	Each axis	$\pm 5$			g
Initial Sensitivity	16-bit data format <sup>4</sup>		0.25		mg/LSB
	32-bit data format <sup>4</sup>		$3.81 \times 10^{-6}$		mg/LSB
Repeatability <sup>2</sup>	$0^\circ\text{C} \leq T_A \leq 70^\circ\text{C}$			1	%
Sensitivity Temperature Coefficient	$0^\circ\text{C} \leq T_A \leq 70^\circ\text{C}$		$\pm 15$		ppm/ $^\circ\text{C}$
Misalignment	Axis to axis		$\pm 0.05$		Degrees
	Axis to frame (package)		$\pm 1$		Degrees
Nonlinearity	Best fit straight line		$\pm 0.1$		% of FS
Bias Repeatability <sup>2,3</sup>	$0^\circ\text{C} \leq T_A \leq +70^\circ\text{C}$ , $1\sigma$		$\pm 15$		mg
In-Run Bias Stability	$1\sigma$		0.2		mg
Velocity Random Walk	$1\sigma$		0.09		m/sec/ $\sqrt{\text{hr}}$
Bias Temperature Coefficient	$0^\circ\text{C} \leq T_A \leq 70^\circ\text{C}$		$\pm 0.05$		mg/ $^\circ\text{C}$
Vibration Rectification Error	20 Hz to 2000 Hz, 1 g rms		0.08		mg/g <sup>2</sup>
Bias Supply Sensitivity	$3.15\text{ V} \leq V_{DD} \leq 3.45\text{ V}$		72		mg/V
Output Noise	No filtering		4.5		mg rms
Noise Density	10 Hz to 40 Hz, no filtering		0.2		mg/ $\sqrt{\text{Hz rms}}$
-3 dB Bandwidth			350		Hz
Sensor Resonant Frequency			5.5		kHz
<b>TEMPERATURE</b>					
Sensitivity	See Table 37		0.05		$^\circ\text{C}/\text{LSB}$
<b>LOGIC INPUTS<sup>5</sup></b>					
Input High Voltage, $V_{IH}$		2.0			V
Input Low Voltage, $V_{IL}$				0.8	V
Logic 1 Input Current, $I_{IH}$	$V_{IH} = 3.3\text{ V}$		$\pm 0.2$	$\pm 10$	$\mu\text{A}$

Parameter	Test Conditions/Comments	Min	Typ	Max	Unit
Logic 0 Input Current, $I_{IL}$ All Pins Except $\overline{RST}$ $\overline{RST}$ Pin	$V_{IL} = 0\text{ V}$		40 1	60	$\mu\text{A}$ mA
Input Capacitance, $C_{IN}$			10		pF
DIGITAL OUTPUTS <sup>5</sup> Output High Voltage, $V_{OH}$ Output Low Voltage, $V_{OL}$	$I_{SOURCE} = 1.6\text{ mA}$ $I_{SINK} = 1.6\text{ mA}$	2.4		0.4	V V
FLASH MEMORY Data Retention <sup>7</sup>	Endurance <sup>6</sup> $T_J = 85^\circ\text{C}$	10,000 20			Cycles Years
FUNCTIONAL TIMES <sup>8</sup> Power-On Start-Up Time Reset Recovery Time <sup>9, 10</sup> Reset Initiation Time <sup>11</sup>	Time until new data is available		290 222 10		ms ms $\mu\text{s}$
CONVERSION RATE $x\_GYRO\_OUT$ , $x\_ACCL\_OUT$ Clock Accuracy Sync Input Clock <sup>12</sup> PPS Input Clock	$MSC\_CTRL[3:2] = 01$ $MSC\_CTRL[3:2] = 10$		2048	$\pm 3$ 2000 128	SPS % Hz Hz
POWER SUPPLY Power Supply Current	Operating voltage range, VDD $VDD = 3.15\text{ V}$	3.15	3.3 44	3.45 55	V mA

<sup>1</sup> The X\_GYRO\_LOW (see Table 10), Y\_GYRO\_LOW (see Table 12), and Z\_GYRO\_LOW (see Table 14) registers capture the bit growth associated with the user configurable filters.

<sup>2</sup> The repeatability specifications represent analytical projections, which are based on the following drift contributions and conditions: temperature hysteresis (0°C to 70°C), electronics drift (high temperature operating life test: 85°C, 500 hours), drift from temperature cycling (JEDEC22, Method A104-C, Method N, 500 cycles, -40°C to +85°C), rate random walk (10 year projection), and broadband noise.

<sup>3</sup> Bias repeatability describes a long-term behavior, over a variety of conditions. Short-term repeatability is related to the in-run bias stability and noise density specifications.

<sup>4</sup> The X\_ACCL\_LOW (see Table 24), Y\_ACCL\_LOW (see Table 26), and Z\_ACCL\_LOW (see Table 28) registers capture the bit growth associated with the user configurable filters.

<sup>5</sup> The digital I/O signals are driven by an internal 3.3 V supply, and the inputs are 5 V tolerant.

<sup>6</sup> Endurance is qualified as per JEDEC Standard 22, Method A117, and measured at -40°C, +25°C, +85°C, and +125°C.

<sup>7</sup> The data retention lifetime equivalent is at a junction temperature ( $T_J$ ) of 85°C as per JEDEC Standard 22, Method A117. Data retention lifetime decreases with junction temperature.

<sup>8</sup> These times do not include thermal settling and internal filter response times (375 Hz bandwidth), which may affect overall accuracy.

<sup>9</sup> The parameter assumes that a full start-up sequence has taken place, prior to initiation of the reset cycle.

<sup>10</sup> This parameter represents the time between raising the  $\overline{RST}$  line and restoration of pulsing on the DR line, which indicates a return to normal operation.

<sup>11</sup> This parameter represents the pulse time on the  $\overline{RST}$  line, which ensures initiation of the reset operation.

<sup>12</sup> The sync input clock functions below the specified minimum value but at reduced performance levels.

**TIMING SPECIFICATIONS**

T<sub>A</sub> = 25°C, VDD = 3.3 V, unless otherwise noted.

Table 2.

Parameter	Description	Normal Mode			Burst Read			Unit
		Min <sup>1</sup>	Typ	Max	Min <sup>1</sup>	Typ	Max	
f <sub>SCLK</sub>	Serial clock	0.1		2.0	0.1		1.0	MHz
t <sub>STALL</sub>	Stall period between data	16			N/A <sup>2</sup>			μs
t <sub>READRATE</sub>	Read rate	24						μs
t <sub>CS</sub>	Chip select to SCLK edge	200			200			ns
t <sub>DAV</sub>	DOUT valid after SCLK edge			25			25	ns
t <sub>DSU</sub>	DIN setup time before SCLK rising edge	25			25			ns
t <sub>DHD</sub>	DIN hold time after SCLK rising edge	50			50			ns
t <sub>SCLKR</sub> , t <sub>SCLKF</sub>	SCLK rise/fall times		5	12.5		5	12.5	ns
t <sub>DR</sub> , t <sub>DF</sub>	DOUT rise/fall times		5	12.5		5	12.5	ns
t <sub>SFS</sub>	CS high after SCLK edge	0			0			ns
t <sub>1</sub>	Input sync positive pulse width	25			25			μs
t <sub>STDR</sub>	Input sync to data ready valid transition		636			636		μs
t <sub>NV</sub>	Data invalid time		47			47		μs
t <sub>2</sub>	Input sync period	500			500			μs

<sup>1</sup> Guaranteed by design and characterization, but not tested in production.

<sup>2</sup> When using the burst read mode, the stall period is not applicable.

**Timing Diagrams**

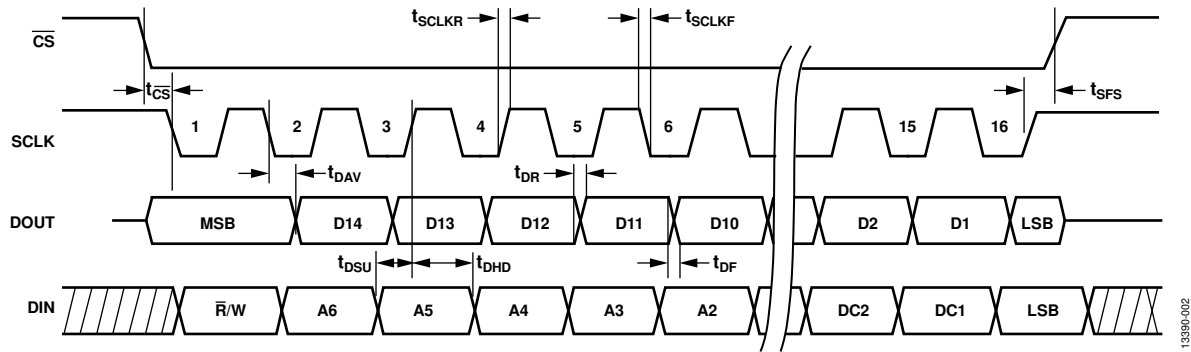

Figure 2. SPI Timing and Sequence

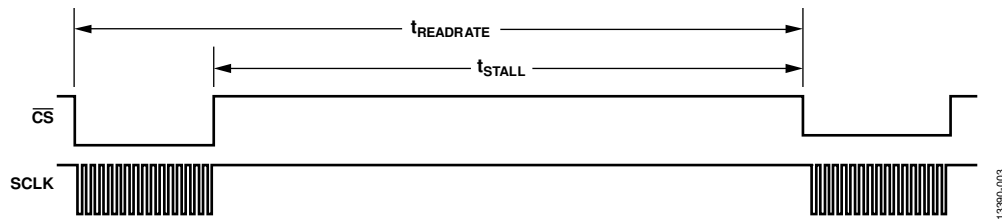

Figure 3. Stall Time and Data Rate

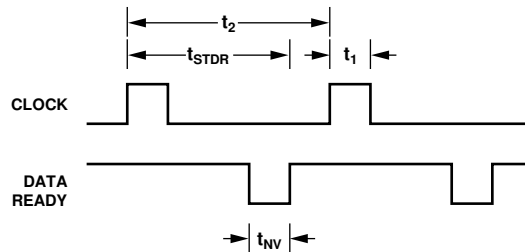

Figure 4. Input Clock Timing Diagram, MSC\_CTRL[0] = 1

## ABSOLUTE MAXIMUM RATINGS

Table 3.

Parameter	Rating
Mechanical Shock Survival	
Any Axis, Unpowered	2000 <i>g</i>
Any Axis, Powered	2000 <i>g</i>
VDD to GND	−0.3 V to +3.45 V
Digital Input Voltage to GND	−0.3 V to +5.3 V
Digital Output Voltage to GND	−0.3 V to +VDD + 0.3 V
Temperature	
Operating Range	−25°C to +85°C
Storage Range	−65°C to +125°C <sup>1,2</sup>

<sup>1</sup> Extended exposure to temperatures outside the specified temperature range of −25°C to +85°C can adversely affect the accuracy of the factory calibration. For best accuracy, store the parts within the specified operating range of −25°C to +85°C.

<sup>2</sup> Although the device is capable of withstanding short-term exposure to 150°C, long-term exposure threatens internal mechanical integrity.

Stresses at or above those listed under Absolute Maximum Ratings may cause permanent damage to the product. This is a stress rating only; functional operation of the product at these or any other conditions above those indicated in the operational section of this specification is not implied. Operation beyond the maximum operating conditions for extended periods may affect product reliability.

Table 4. Package Characteristics

Package Type	$\theta_{JA}$ (°C/W)	$\theta_{JC}$ (°C/W)	Mass (grams)
14-Lead Module	36.5	16.9	15

### ESD CAUTION



**ESD (electrostatic discharge) sensitive device.** Charged devices and circuit boards can discharge without detection. Although this product features patented or proprietary protection circuitry, damage may occur on devices subjected to high energy ESD. Therefore, proper ESD precautions should be taken to avoid performance degradation or loss of functionality.



# PIN CONFIGURATION AND FUNCTION DESCRIPTIONS

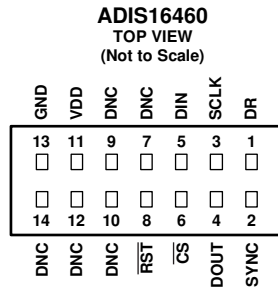

**NOTES**

1. THIS REPRESENTS THE PIN ASSIGNMENTS WHEN LOOKING DOWN AT THE CONNECTOR. SEE FIGURE 6.
2. MATING CONNECTOR:  
SAMTEC CLM-107-02 SERIES OR EQUIVALENT.
3. DNC = DO NOT CONNECT.

13390-005

Figure 5. Pin Configuration

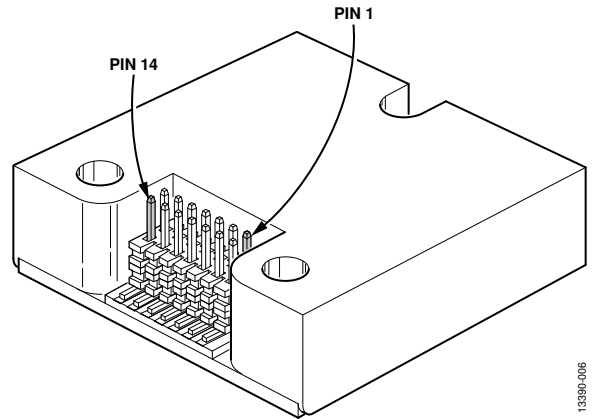

13390-006

Figure 6. Pin Locations

**Table 5. Pin Function Descriptions**

Pin No.	Mnemonic	Type	Description
1	DR	Output	Data Ready Indicator.
2	SYNC	Input/Output	External Sync Input/Output, per MSC_CTRL. See Table 50.
3	SCLK	Input	SPI Serial Clock.
4	DOUT	Output	SPI Data Output. This pin clocks the output on the SCLK falling edge.
5	DIN	Input	SPI Data Input. This pin clocks the input on the SCLK rising edge.
6	CS	Input	SPI Chip Select.
7	DNC	Not applicable	Do Not Connect. Do not connect to this pin.
8	RST	Input	Reset.
9	DNC	Not applicable	Do Not Connect. Do not connect to this pin.
10	DNC	Not applicable	Do Not Connect. Do not connect to this pin.
11	VDD	Supply	Power Supply.
12	DNC	Not applicable	Do Not Connect. Do not connect to this pin.
13	GND	Supply	Power Ground.
14	DNC	Not applicable	Do Not Connect. Do not connect to this pin.

TYPICAL PERFORMANCE CHARACTERISTICS

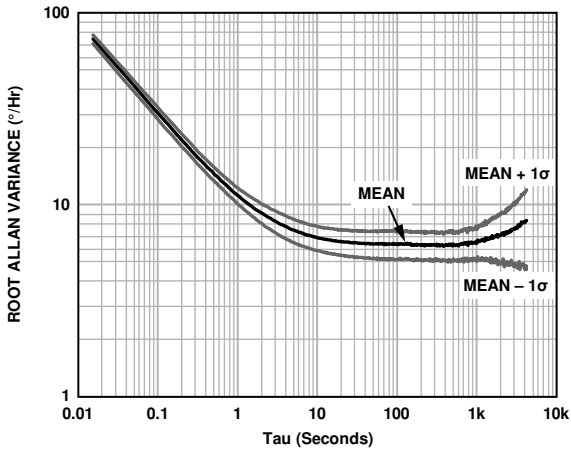

Figure 7. Gyroscope Root Allan Variance

13390-007

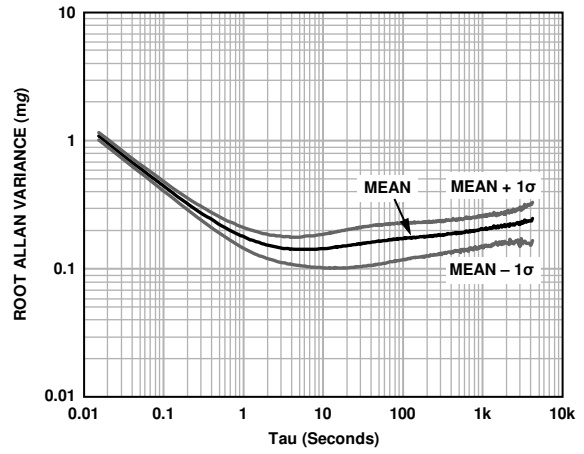

Figure 10. Accelerometer Root Allan Variance

13390-008

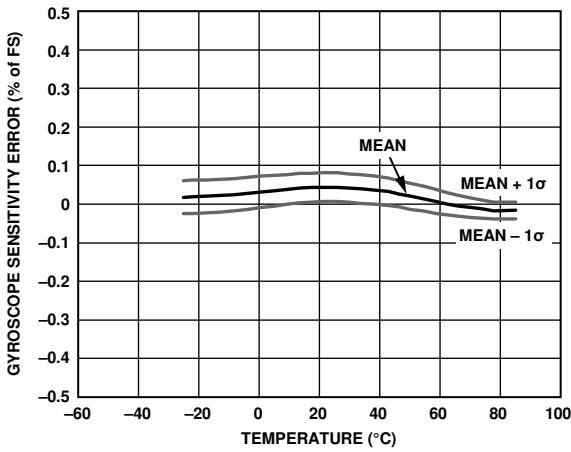

Figure 8. Gyroscope Sensitivity Error vs. Cold to Hot Temperature Sweep

13390-100

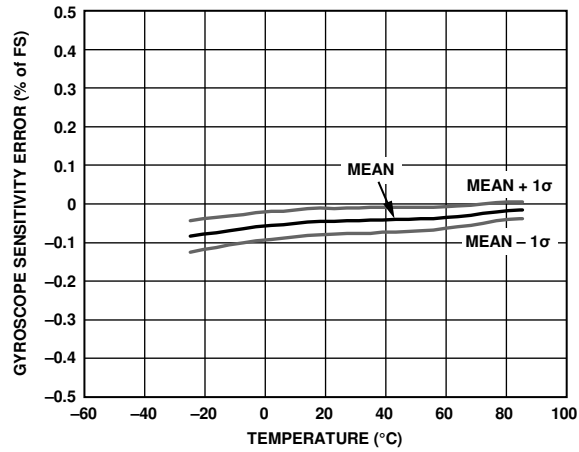

Figure 11. Gyroscope Sensitivity Error vs. Hot to Cold Temperature Sweep

13390-101

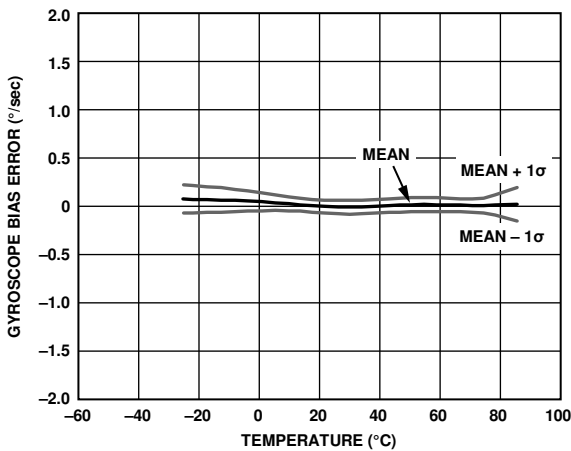

Figure 9. Gyroscope Bias Error vs. Cold to Hot Temperature Sweep

13390-102

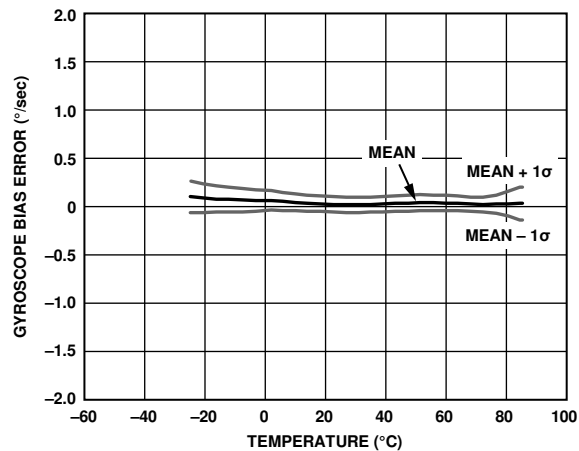

Figure 12. Gyroscope Bias Error vs. Hot to Cold Temperature Sweep

13390-103

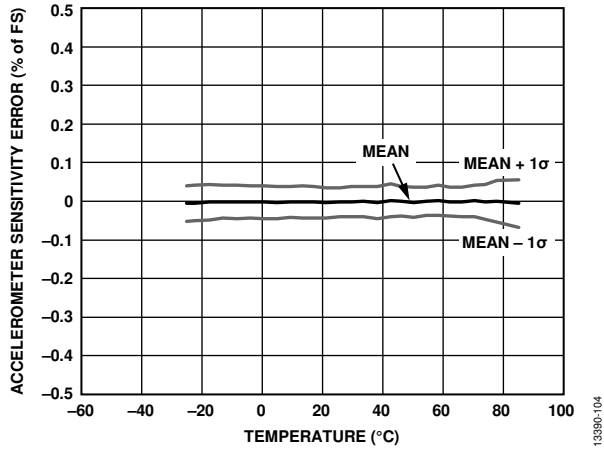

Figure 13. Accelerometer Sensitivity Error vs. Cold to Hot Temperature Sweep

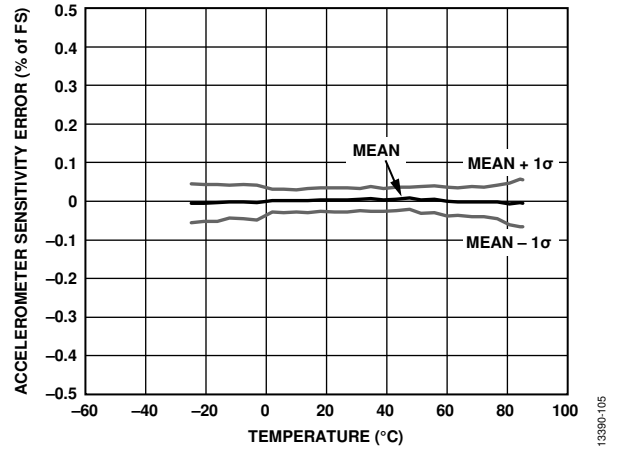

Figure 15. Accelerometer Sensitivity Error vs. Hot to Cold Temperature Sweep

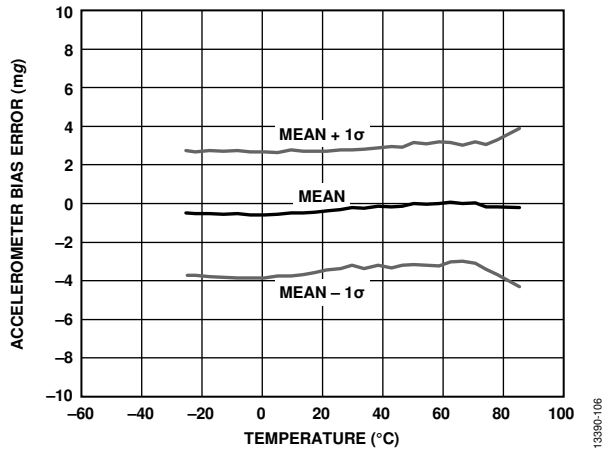

Figure 14. Accelerometer Bias Error vs. Cold to Hot Temperature Sweep

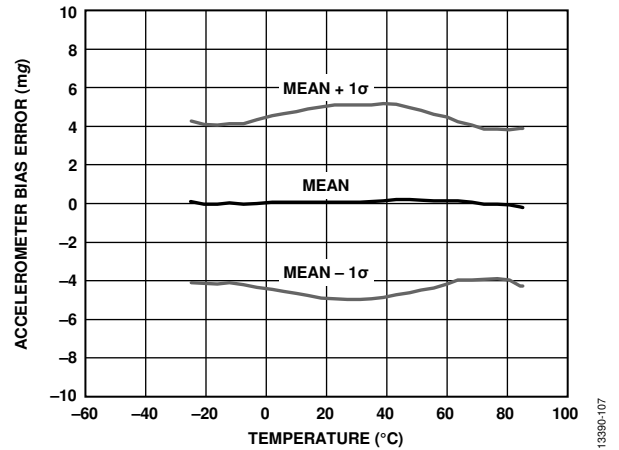

Figure 16. Accelerometer Bias Error vs. Hot to Cold Temperature Sweep

# THEORY OF OPERATION

The ADIS16460 is an autonomous sensor system that requires no user initialization. When it has an adequate power supply across the VDD and GND pins, it initializes itself and starts sampling, processing, and loading sensor data into the output registers at a sample rate of 2048 SPS. The DR pin (see Figure 5) pulses high after each sample cycle concludes. The SPI interface enables simple integration with many embedded processor platforms, as shown in Figure 17 (electrical connection) and Table 6 (pin functions).

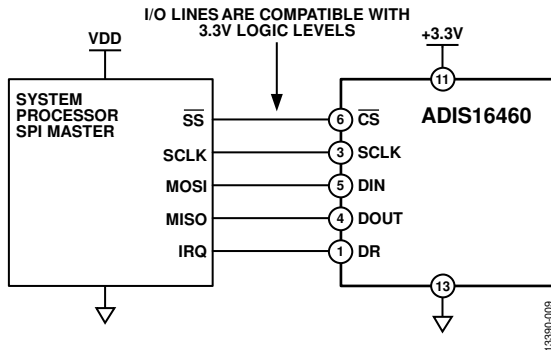

Figure 17. Electrical Connection Diagram

Table 6. Generic Master Processor Pin Names and Functions

Pin Name	Function
SS	Slave select
SCLK	Serial clock
MOSI	Master output, slave input
MISO	Master input, slave output
IRQ	Interrupt request

The ADIS16460 SPI interface supports full duplex serial communication (simultaneous transmit and receive) and uses the bit sequence shown in Figure 20. Table 7 provides a list of the most common settings that require attention to initialize the serial port of a processor for the ADIS16460.

Table 7. Generic Master Processor SPI Settings

Processor Setting	Description
Master	The ADIS16460 operates as a slave
SCLK Rate <sup>1</sup>	Maximum serial clock rate, see Table 2
SPI Mode 3	CPOL = 1 (polarity), CPHA = 1 (phase)
MSB First	Bit sequence, see Figure 20
16-Bit Length	Shift register/data length

<sup>1</sup> For burst read, SCLK rate ≤ 1 MHz.

## READING SENSOR DATA

The ADIS16460 provides two options for acquiring sensor data: a single register and a burst register. A single register read requires two 16-bit SPI cycles. The first cycle requests the contents of a register using the bit assignments in Figure 20. Bit DC7 to Bit DC0 are don't cares for a read, and then the output register contents follow on DOUT during the second sequence. Figure 18 includes three single register reads in succession.

In this example, the process starts with DIN = 0x0600 to request the contents of X\_GYRO\_OUT, then follows with 0x0A00 to request Y\_GYRO\_OUT, and 0x0E00 to request Z\_GYRO\_OUT. Full duplex operation enables processors to use the same 16-bit SPI cycle to read data from DOUT while requesting the next set of data on DIN. Figure 19 provides an example of the four SPI signals when reading X\_GYRO\_OUT in a repeating pattern.

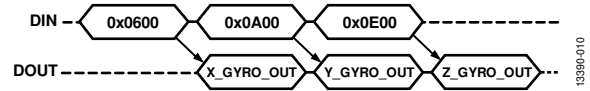

Figure 18. SPI Read Example

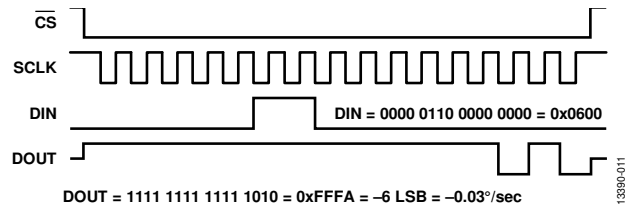
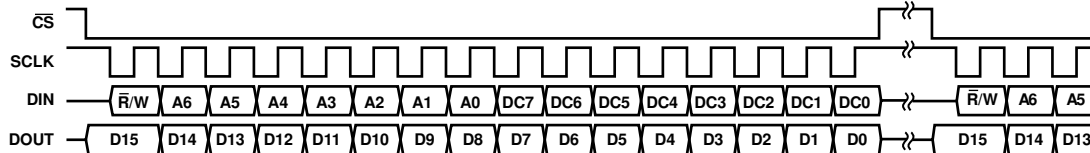

Figure 19. Example SPI Read, Second Sequence



NOTES

1. THE DOUT BIT PATTERN REFLECTS THE ENTIRE CONTENTS OF THE REGISTER IDENTIFIED BY [A6:A0] IN THE PREVIOUS 16-BIT DIN SEQUENCE WHEN R/W = 0.
2. IF R/W = 1 DURING THE PREVIOUS SEQUENCE, DOUT IS NOT DEFINED.

Figure 20. SPI Communication Bit Sequence

**Burst Read Function**

The burst read function provides a way to read all of the data in one continuous stream of bits, with no stall time in between each 16-bit segment. As shown in Figure 21, start this mode by setting DIN = 0x3E00, and then read each of the following registers out, while keeping CS low: DIAG\_STAT, X\_GYRO\_OUT, Y\_GYRO\_OUT, Z\_GYRO\_OUT, X\_ACCL\_OUT, Y\_ACCL\_OUT, Z\_ACCL\_OUT, TEMP\_OUT, SMPL\_CNTR, and checksum. Use the following formula to verify the checksum value, while treating each byte in the formula as an independent, unsigned, 8-bit number.

$$\begin{aligned}
 \text{Checksum} = & \text{DIAG\_STAT}[15:8] + \text{DIAG\_STAT}[7:0] + \\
 & \text{X\_GYRO\_OUT}[15:8] + \text{X\_GYRO\_OUT}[7:0] + \\
 & \text{Y\_GYRO\_OUT}[15:8] + \text{Y\_GYRO\_OUT}[7:0] + \\
 & \text{Z\_GYRO\_OUT}[15:8] + \text{Z\_GYRO\_OUT}[7:0] + \\
 & \text{X\_ACCL\_OUT}[15:8] + \text{X\_ACCL\_OUT}[7:0] + \\
 & \text{Y\_ACCL\_OUT}[15:8] + \text{Y\_ACCL\_OUT}[7:0] + \\
 & \text{Z\_ACCL\_OUT}[15:8] + \text{Z\_ACCL\_OUT}[7:0] + \\
 & \text{TEMP\_OUT}[15:8] + \text{TEMP\_OUT}[7:0] + \\
 & \text{SMPL\_CNTR}[15:8] + \text{SMPL\_CNTR}[7:0]
 \end{aligned}$$

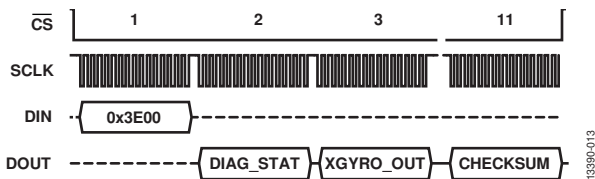

Figure 21. Burst Read Sequence

**SPI Read Test Sequence**

Figure 22 provides a test pattern for testing the SPI communication. In this pattern, write 0x5600 to the DIN line in a repeating pattern and raise the chip select for a time that meets the stall time requirement (see Table 2) each 16-bit sequence. Starting with the second 16-bit sequence, DOUT produces the contents of the PROD\_ID register, 0x404C (see Table 41).

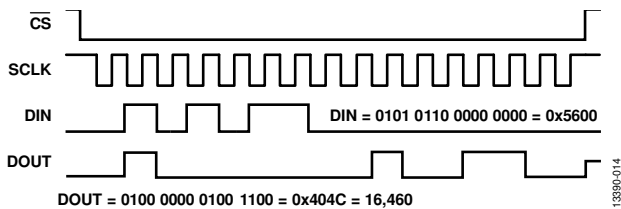

Figure 22. SPI Test Read Pattern DIN = 0x5600, DOUT = 0x404C

**DEVICE CONFIGURATION**

The control registers in Table 8 provide users with a variety of configuration options. The SPI provides access to these registers, one byte at a time, using the bit assignments in Figure 20. Each register has 16 bits, where Bits[7:0] represent the lower address, and Bits[15:8] represent the upper address. Figure 23 provides an example of writing 0x01 to Address 0x3E (GLOB\_CMD[1], using DIN = 0xBE01).

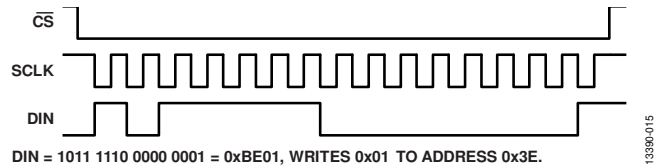

Figure 23. Example SPI Write Sequence

**Dual Memory Structure**

Writing configuration data to a control register updates its SRAM contents, which are volatile. After optimizing each relevant control register setting in a system, set GLOB\_CMD[3] = 1 (DIN = 0xBE08) to copy these settings into nonvolatile flash memory. The flash update process requires a valid power supply level for the entire process time (see Table 44). Table 8 provides a memory map for the user registers, which includes a flash backup column. A yes in this column indicates that a register has a mirror location in flash and, when backed up properly, it automatically restores itself during startup or after a reset. Figure 24 provides a diagram of the dual memory structure used to manage operation and store critical user settings.

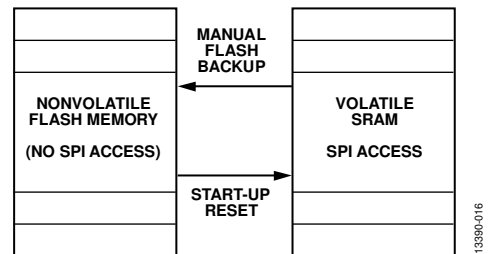

Figure 24. SRAM and Flash Memory Diagram

## USER REGISTERS

Table 8. User Register Memory Map<sup>1</sup>

Name	R/W	Flash Backup	Address <sup>2</sup>	Default	Function	Bit Assignments
FLASH_CNT	R	Yes	0x00	N/A	Flash memory write count	See Table 49
DIAG_STAT	R	No	0x02	0x0000	Diagnostic and operational status	See Table 43
X_GYRO_LOW	R	No	0x04	N/A	X-axis gyroscope output, lower word	See Table 10
X_GYRO_OUT	R	No	0x06	N/A	X-axis gyroscope output, upper word	See Table 11
Y_GYRO_LOW	R	No	0x08	N/A	Y-axis gyroscope output, lower word	See Table 12
Y_GYRO_OUT	R	No	0x0A	N/A	Y-axis gyroscope output, upper word	See Table 13
Z_GYRO_LOW	R	No	0x0C	N/A	Z-axis gyroscope output, lower word	See Table 14
Z_GYRO_OUT	R	No	0x0E	N/A	Z-axis gyroscope output, upper word	See Table 15
X_ACCL_LOW	R	No	0x10	N/A	X-axis accelerometer output, lower word	See Table 24
X_ACCL_OUT	R	No	0x12	N/A	X-axis accelerometer output, upper word	See Table 25
Y_ACCL_LOW	R	No	0x14	N/A	Y-axis accelerometer output, lower word	See Table 26
Y_ACCL_OUT	R	No	0x16	N/A	Y-axis accelerometer output, upper word	See Table 27
Z_ACCL_LOW	R	No	0x18	N/A	Z-axis accelerometer output, lower word	See Table 28
Z_ACCL_OUT	R	No	0x1A	N/A	Z-axis accelerometer output, upper word	See Table 29
SMPL_CNTR	R	No	0x1C	N/A	Sample counter, MSC_CTRL[3:2] = 11	See Table 52
TEMP_OUT	R	No	0x1E	N/A	Temperature (internal, not calibrated)	See Table 37
Reserved	N/A	N/A	0x20, 0x22	N/A	Reserved, do not use	N/A
X_DELT_ANG	R	No	0x24	N/A	X-axis delta angle output	See Table 18
Y_DELT_ANG	R	No	0x26	N/A	Y-axis delta angle output	See Table 19
Z_DELT_ANG	R	No	0x28	N/A	Z-axis delta angle output	See Table 20
X_DELT_VEL	R	No	0x2A	N/A	X-axis delta velocity	See Table 32
Y_DELT_VEL	R	No	0x2C	N/A	Y-axis delta velocity	See Table 33
Z_DELT_VEL	R	No	0x2E	N/A	Z-axis delta velocity	See Table 34
Reserved	N/A	N/A	0x30	N/A	Reserved, do not use	N/A
MSC_CTRL	R/W	Yes	0x32	0x00C1	Miscellaneous control	See Table 50
SYNC_SCAL	R/W	Yes	0x34	0x7FFF	Sync input scale control	See Table 51
DEC_RATE	R/W	Yes	0x36	0x0000	Decimation rate control	See Table 53
FLTR_CTRL	R/W	Yes	0x38	0x0500	Filter control, autonull record time	See Table 54
Reserved	N/A	N/A	0x3A, 0x3C	N/A	Reserved, do not use	N/A
GLOB_CMD	W	No	0x3E	N/A	Global commands	See Table 44
X_GYRO_OFF	R/W	Yes	0x40	0x0000	X-axis gyroscope bias offset factor	See Table 55
Y_GYRO_OFF	R/W	Yes	0x42	0x0000	Y-axis gyroscope bias offset factor	See Table 56
Z_GYRO_OFF	R/W	Yes	0x44	0x0000	Z-axis gyroscope bias offset factor	See Table 57
X_ACCL_OFF	R/W	Yes	0x46	0x0000	X-axis acceleration bias offset factor	See Table 58
Y_ACCL_OFF	R/W	Yes	0x48	0x0000	Y-axis acceleration bias offset factor	See Table 59
Z_ACCL_OFF	R/W	Yes	0x4A	0x0000	Z-axis acceleration bias offset factor	See Table 60
Reserved	N/A	N/A	0x4C, 0x4E, 0x50	N/A	Reserved, do not use	N/A
LOT_ID1	R	Yes	0x52	N/A	Lot Identification Number 1	See Table 39
LOT_ID2	R	Yes	0x54	N/A	Lot Identification Number 2	See Table 40
PROD_ID	R	Yes	0x56	0x404C	Product identifier	See Table 41
SERIAL_NUM	R	Yes	0x58	N/A	Lot specific serial number	See Table 42
CAL_SGNTR	R	N/A	0x60	N/A	Calibration memory signature value	See Table 46
CAL_CRC	R	N/A	0x62	N/A	Calibration memory CRC values	See Table 48
CODE_SGNTR	R	N/A	0x64	N/A	Code memory signature value	See Table 45
CODE_CRC	R	N/A	0x66	N/A	Code memory CRC values	See Table 47

<sup>1</sup> N/A means not applicable.<sup>2</sup> Each register contains two bytes. The address on display is for the lower byte. The address of the upper byte is equal to the address of the lower byte plus 1.

## OUTPUT DATA REGISTERS

The output data registers contain inertial sensor (gyroscopes, accelerometers) measurements, delta angle calculations, delta velocity calculations, and a relative temperature monitor.

### ROTATION

The ADIS16460 uses iMEMS gyroscopes to provide inertial rotation measurements around three orthogonal axes, in two different formats: angular rate and angular displacement (delta-angles). Figure 26 shows the axial assignments and the direction of rotation that corresponds to a positive response in their respective output registers (see Table 9).

#### Angular Rate Data

The angular rate of rotation data represents the calibrated response from the tri-axis MEMS gyroscopes. Six registers provide real-time access to these measurements. Each axis has two dedicated registers: a primary and a secondary register. Table 9 provides the register assignments for each of the three axes ( $\omega_x$ ,  $\omega_y$ ,  $\omega_z$ ) in Figure 26.

Table 9. Angular Rate of Rotation Data Registers

Axis	Primary Register	Secondary Register
$\omega_x$	X_GYRO_OUT (see Table 11)	X_GYRO_LOW (see Table 10)
$\omega_y$	Y_GYRO_OUT (see Table 13)	Y_GYRO_LOW (see Table 12)
$\omega_z$	Z_GYRO_OUT (see Table 15)	Z_GYRO_LOW (see Table 14)

The primary register provides a 16-bit, twos complement number, where the scale factor ( $K_G$ ) is equal to  $0.005^\circ/\text{sec}/\text{LSB}$ . The secondary register provides users with the ability to capture the bit growth that is associated with the summation functions in the user configurable digital filters (see Table 53 and Table 54). Figure 25 illustrates how the primary ( $X\_GYRO\_OUT$ ) and secondary ( $X\_GYRO\_LOW$ ) registers combine to provide a digital result that supports up to 32 bits of digital resolution for the angular rate of rotation around the x-axis.

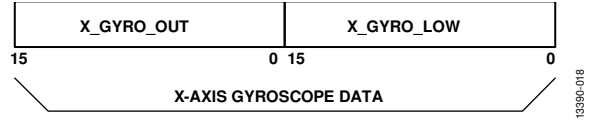

Figure 25. 32-Bit Gyroscope Data Format

Table 10. X\_GYRO\_LOW (Base Address = 0x04), Read Only

Bits	Description
[15:0]	X-axis, gyroscope, output data Bit growth from X_GYRO_OUT data path

Table 11. X\_GYRO\_OUT (Base Address = 0x06), Read Only

Bits	Description
[15:0]	X-axis, gyroscope output data, $0.005^\circ/\text{sec}/\text{LSB}$ ( $K_G$ ) $0^\circ/\text{sec} = 0x0000$ , twos complement format

Table 12. Y\_GYRO\_LOW (Base Address = 0x08), Read Only

Bits	Description
[15:0]	Y-axis, gyroscope, output data Bit growth from Y_GYRO_OUT data path

Table 13. Y\_GYRO\_OUT (Base Address = 0x0A), Read Only

Bits	Description
[15:0]	Y-axis, gyroscope output data, $0.005^\circ/\text{sec}/\text{LSB}$ ( $K_G$ ) $0^\circ/\text{sec} = 0x0000$ , twos complement format

Table 14. Z\_GYRO\_LOW (Base Address = 0x0C), Read Only

Bits	Description
[15:0]	Z-axis, gyroscope, output data Bit growth from Z_GYRO_OUT data path

Table 15. Z\_GYRO\_OUT (Base Address = 0x0E), Read Only

Bits	Description
[15:0]	Z-axis, gyroscope output data, $0.005^\circ/\text{sec}/\text{LSB}$ ( $K_G$ ) $0^\circ/\text{sec} = 0x0000$ , twos complement format

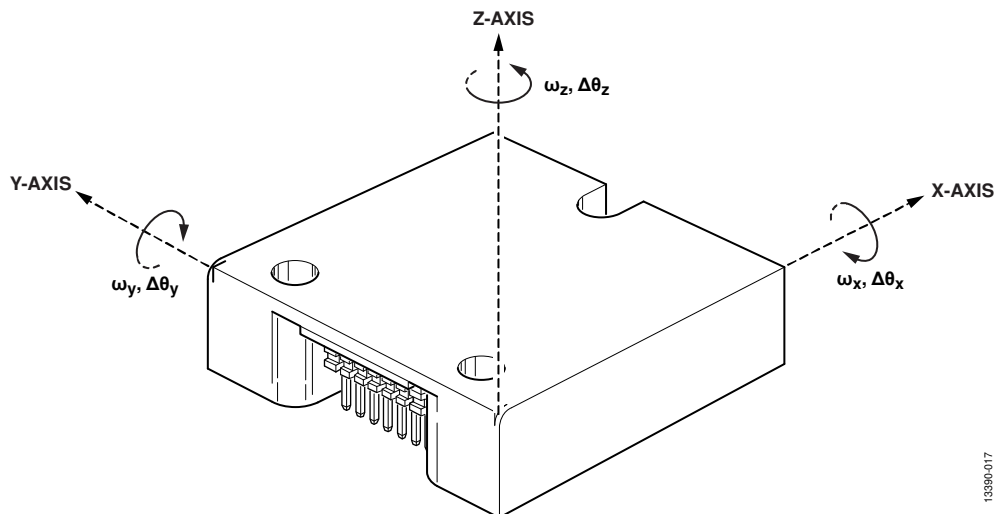

Figure 26. Inertial Sensor Definitions

Table 16 provides seven examples of the digital data format when using only the primary registers for 16-bit measurements.

**Table 16. Rotation Rate, 16-Bit Example**

Rotation Rate (°/sec)	Decimal	Hex	Binary
+100	20,000	0x4E20	0100 1110 0010 0000
+0.01	+2	0x0002	0000 0000 0000 0010
+0.005	+1	0x0001	0000 0000 0000 0001
0	0	0x0000	0000 0000 0000 0000
-0.005	-1	0xFFFF	1111 1111 1111 1111
-0.01	-2	0xFFFE	1111 1111 1111 1110
-100	-20,000	0xB1E0	1011 0001 1110 0000

Many, if not all, applications do not require all 32 bits of digital resolution to preserve key sensor performance criteria. When truncating the data width to a lower number of bits, use the following formula to calculate the scale factor for the least significant bit:

$$1 \text{ LSB} = K_G \times \frac{1}{2^{N-16}}$$

where  $N$  is the total number of bits.

For example, if the system uses four bits from the  $x\_GYRO\_LOW$  registers, the data width is 20 bits and the LSB weight is equal to  $0.0003215^\circ/\text{sec}$ .

$$1 \text{ LSB} = 0.005^\circ/\text{sec} \times \frac{1}{2^{20-16}}$$

$$1 \text{ LSB} = 0.005^\circ/\text{sec} \times \frac{1}{16} = 0.0003125^\circ/\text{sec}$$

Table 17 provides seven examples of the digital data format when using the primary and the secondary registers to produce a 20-bit number for the angular rate of rotation.

**Table 17. Rotation Rate, 20-Bit Example**

Rotation Rate (°/sec)	Decimal	Hex	Binary
+100	+320,000	0x4E200	0100 1110 0010 0000 0000
+0.000625	+2	0x00002	0000 0000 0000 0000 0010
+0.0003125	+1	0x00001	0000 0000 0000 0000 0001
0	0	0x00000	0000 0000 0000 0000 0000
-0.0003125	-1	0xFFFFF	1111 1111 1111 1111 1111
-0.000625	-2	0xFFFFE	1111 1111 1111 1111 1110
-100	-320,000	0xB1E00	1011 0001 1110 0000 0000

**Delta Angle Data**

The delta angle measurements ( $\Delta\theta_x, \Delta\theta_y, \Delta\theta_z$  in Figure 26) represent the angular displacement around each axis, during each data processing cycle. Three registers provide real-time access to these measurements, with each axis ( $x, y, z$ ) having its own dedicated register.  $X\_DELTA\_ANG$  (see Table 18) is the output data register for the  $x$ -axis ( $\Delta\theta_x$  in Figure 26),  $Y\_DELTA\_ANG$  (see Table 19) is the output data register for the  $y$ -axis ( $\Delta\theta_y$  in Figure 26), and  $Z\_DELTA\_ANG$  (see Table 20) is the output data register for the  $z$ -axis ( $\Delta\theta_z$  in Figure 26). The scale factors for these registers depend on the scale factor for the gyroscopes (see Table 11,  $K_G = 0.005^\circ/\text{sec}/\text{LSB}$ ), sample clock ( $f_{\text{SAMPLE}}$ ),

related to  $MSC\_CTRL[3:2]$  (see Table 50), and the decimation rate settings ( $DEC\_RATE$ , see Table 53).

**Table 18. X\_DELTA\_ANG (Base Address = 0x24), Read Only**

Bits	Description
[15:0]	X-axis, delta angle output data $0^\circ = 0x0000$ , twos complement format $1 \text{ LSB} = K_G \times (\text{DEC\_RATE} + 1)/f_{\text{SAMPLE}}$ (degrees) $f_{\text{SAMPLE}} = 2048 \text{ Hz}$ when $MSC\_CTRL[3:2] = 00$ $f_{\text{SAMPLE}}$ is the external clock rate when $MSC\_CTRL[3:2] \neq 00$

**Table 19. Y\_DELTA\_ANG (Base Address = 0x26), Read Only**

Bits	Description
[15:0]	Y-axis, delta angle output data $0^\circ = 0x0000$ , twos complement format $1 \text{ LSB} = K_G \times (\text{DEC\_RATE} + 1)/f_{\text{SAMPLE}}$ (degrees) $f_{\text{SAMPLE}} = 2048 \text{ Hz}$ when $MSC\_CTRL[3:2] = 00$ $f_{\text{SAMPLE}}$ is the external clock rate when $MSC\_CTRL[3:2] \neq 00$

**Table 20. Z\_DELTA\_ANG (Base Address = 0x28), Read Only**

Bits	Description
[15:0]	Z-axis, delta angle output data $0^\circ = 0x0000$ , twos complement format $1 \text{ LSB} = K_G \times (\text{DEC\_RATE} + 1)/f_{\text{SAMPLE}}$ (degrees) $f_{\text{SAMPLE}} = 2048 \text{ Hz}$ when $MSC\_CTRL[3:2] = 00$ $f_{\text{SAMPLE}}$ is the external clock rate when $MSC\_CTRL[3:2] \neq 00$

Table 21 illustrates the delta angle data format with numerical examples when  $MSC\_CTRL[3:2] = 00$  ( $f_{\text{SAMPLE}} = 2048 \text{ Hz}$ ) and  $DEC\_RATE = 0x0000$ .

**Table 21. x\_DELTA\_ANG Data Format, Example 1**

Angle (°) <sup>1</sup>	Decimal	Hex	Binary
+0.079998	+32,767	0x7FFF	0111 1111 1111 1111
+0.000048828	+2	0x0002	0000 0000 0000 0010
+0.000024414	+1	0x0001	0000 0000 0000 0001
0	0	0x0000	0000 0000 0000 0000
-0.000024414	-1	0xFFFF	1111 1111 1111 1111
-0.000048828	-2	0xFFFE	1111 1111 1111 1110
-0.080000	-32,768	0x8000	1000 0000 0000 0000

<sup>1</sup>  $MSC\_CTRL[3:2] = 00, DEC\_RATE = 0x0000$ .

Table 22 illustrates the delta-angle data format with numerical examples when  $MSC\_CTRL[3:2] = 01$ , the external clock ( $f_{\text{SAMPLE}}$ ) is 2000 Hz, and  $DEC\_RATE = 0x0009$ .

**Table 22. x\_DELTA\_ANG Data Format, Example 2**

Angle (°) <sup>1</sup>	Decimal	Hex	Binary
+0.81918	+32,767	0x7FFF	0111 1111 1111 1111
+0.000050	+2	0x0002	0000 0000 0000 0010
+0.000025	+1	0x0001	0000 0000 0000 0001
0	0	0x0000	0000 0000 0000 0000
-0.000025	-1	0xFFFF	1111 1111 1111 1111
-0.000050	-2	0xFFFE	1111 1111 1111 1110
-0.81920	-32,768	0x8000	1000 0000 0000 0000

<sup>1</sup>  $MSC\_CTRL[3:2] = 01, DEC\_RATE = 0x0009, f_{\text{SAMPLE}} = 2000 \text{ Hz}$ .



**ACCELEROMETERS**

The ADIS16460 uses iMEMS accelerometers to provide linear inertial measurements along three orthogonal axes, in two different formats: linear acceleration and delta velocity.

Figure 28 shows the axial assignments, the direction of linear acceleration that corresponds to a positive response in their respective output registers (see Table 9).

**Linear Acceleration**

The linear acceleration measurements represent the calibrated response from the tri-axis MEMS accelerometers. Six registers provide real-time access to these measurements. Each axis has two dedicated registers: a primary register and a secondary register. Table 23 provides the register assignments for each of the three axes ( $a_x$ ,  $a_y$ ,  $a_z$ ) in Figure 28.

**Table 23. Linear Acceleration Data Registers**

Axis	Primary Register	Secondary Register
$a_x$	X_ACCL_OUT (see Table 25)	X_ACCL_LOW (see Table 24)
$a_y$	Y_ACCL_OUT (see Table 27)	Y_ACCL_LOW (see Table 26)
$a_z$	Z_ACCL_OUT (see Table 29)	Z_ACCL_LOW (see Table 28)

The primary register provides a 16-bit, twos complement number, where the scale factor ( $K_A$ ) is equal 0.25 mg/LSB. The secondary register provides users with the ability to capture the bit growth that is associated with the summation functions in the user configurable digital filters (see Table 53 and Table 54). Figure 27 illustrates how the primary (X\_ACCL\_OUT) and secondary (X\_ACCL\_LOW) registers combine to provide a digital result that supports up to 32 bits of digital resolution for linear acceleration along the x-axis.

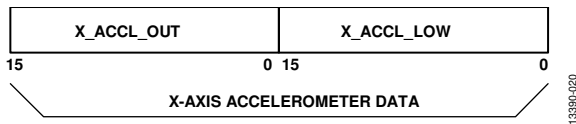

Figure 27. 32-Bit Accelerometer Data Format

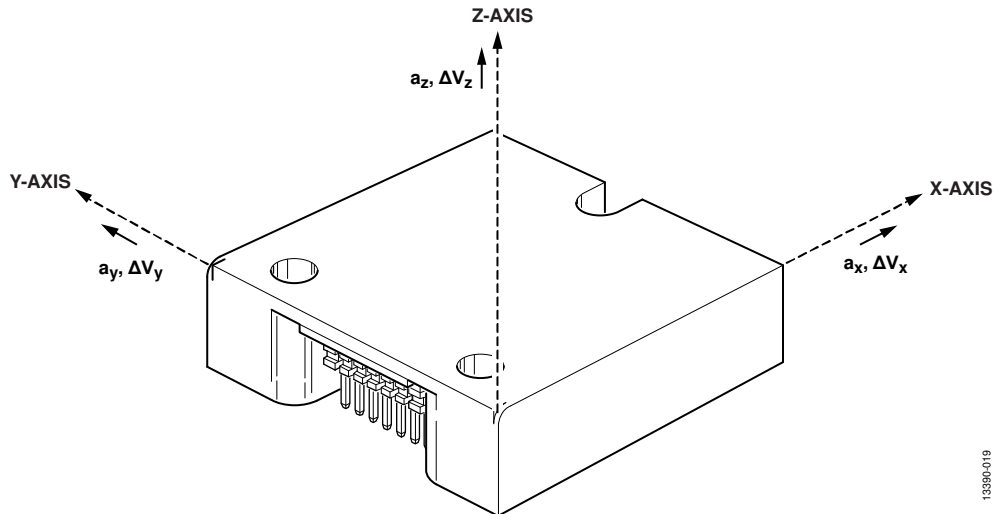

Figure 28. Inertial Sensor Definitions

**Table 24. X\_ACCL\_LOW (Base Address = 0x10) Read Only**

Bits	Description
[15:0]	X-axis, accelerometer, output data Bit growth from X_ACCL_OUT data path

**Table 25. X\_ACCL\_OUT (Base Address = 0x12), Read Only**

Bits	Description
[15:0]	X-axis, accelerometer output data, 0.25 mg /LSB ( $K_A$ ) 0 mg = 0x0000, twos complement format

**Table 26. Y\_ACCL\_LOW (Base Address = 0x14), Read Only**

Bits	Description
[15:0]	Y-axis, accelerometer, output data Bit growth from Y_ACCL_OUT data path

**Table 27. Y\_ACCL\_OUT (Base Address = 0x16), Read Only**

Bits	Description
[15:0]	Y-axis, accelerometer output data, 0.25 mg/LSB ( $K_A$ ) 0 mg = 0x0000, twos complement format

**Table 28. Z\_ACCL\_LOW (Base Address = 0x18), Read Only**

Bits	Description
[15:0]	Z-axis, accelerometer, output data Bit growth from Z_ACCL_OUT data path

**Table 29. Z\_ACCL\_OUT (Base Address = 0x1A), Read Only**

Bits	Description
[15:0]	Z-axis, accelerometer output data, 0.25 mg/LSB ( $K_A$ ) 0 mg = 0x0000, twos complement format

Table 30 provides seven examples of the digital data format when using only the primary registers for 16-bit measurements.

**Table 30. Acceleration, Twos Complement Format**

Acceleration (mg)	Decimal	Hex	Binary
+5000	20,000	0x4E20	0100 1110 0010 0000
+0.5	+2	0x0002	0000 0000 0000 0010
+0.25	+1	0x0001	0000 0000 0000 0001
0	0	0x0000	0000 0000 0000 0000
-0.25	-1	0xFFFF	1111 1111 1111 1111
-0.5	-2	0xFFFE	1111 1111 1111 1110
-5000	-20,000	0xB1E0	1011 0001 1110 0000

Many, if not all, applications do not require all 32 bits of digital resolution to preserve key sensor performance criteria. When truncating the data width to a lower number of bits, use the following formula to calculate the scale factor for the least significant bit:

$$1 \text{ LSB} = K_A \times \frac{1}{2^{N-16}}$$

where *N* is the total number of bits.

For example, if the system uses two bits from the *x\_ACCL\_LOW* registers, the data width is 18 bits and the LSB weight is equal to 0.0625 mg.

$$1 \text{ LSB} = 0.25 \text{ mg} \times \frac{1}{2^{18-16}}$$

$$1 \text{ LSB} = 0.25 \text{ mg} \times \frac{1}{4} = 0.0625 \text{ mg}$$

Table 31 provides seven examples of the digital data format when using the primary and secondary registers to produce an 18-bit number for the angular rate of rotation.

**Table 31. Acceleration, 18-Bit Example**

Acceleration (mg)	Decimal	Hex	Binary
+5000	80,000	0x13880	01 0011 1000 1000 0000
+0.125	+2	0x00002	00 0000 0000 0000 0010
+0.0625	+1	0x00001	00 0000 0000 0000 0001
0	0	0x00000	00 0000 0000 0000 0000
-0.0625	-1	0x3FFFF	11 1111 1111 1111 1111
-0.125	-2	0x3FFFE	11 1111 1111 1111 1110
-5000	-80,000	0x2C780	10 1100 0111 1000 0000

**Delta Velocity Data**

The delta velocity measurements ( $\Delta V_x$ ,  $\Delta V_y$ ,  $\Delta V_z$  in Figure 28) represent the change in velocity along each axis, during each data processing cycle. Three registers provide real-time access to these measurements, with each axis (x, y, z) having its own dedicated register. *X\_DELT\_VEL* (see Table 32) is the output data register for the x-axis ( $\Delta V_x$  in Figure 28), *Y\_DELT\_VEL* (see Table 33) is the output data register for the y-axis ( $\Delta V_y$  in Figure 28), and *Z\_DELT\_VEL* (see Table 34) is the output data register for the z-axis ( $\Delta V_z$  in Figure 28). The scale factors for these registers depend on the scale factor for the accelerometers (see Table 25,  $K_A = 0.25 \text{ mg/sec/LSB}$ ), sample clock ( $f_{\text{SAMPLE}}$ ) related to *MSC\_CTRL[3:2]* (see Table 50), and the decimation rate settings (*DEC\_RATE*, see Table 53).

**Table 32. X\_DELT\_VEL (Base Address = 0x2A), Read Only**

Bits	Description
[15:0]	X-axis, delta velocity output data 0° = 0x0000, twos complement format 1 LSB = $K_A \times 10 \times (\text{DEC\_RATE} + 1) / f_{\text{SAMPLE}}$ (mm/sec) $f_{\text{SAMPLE}} = 2048 \text{ Hz}$ when <i>MSC_CTRL[3:2]</i> = 00 $f_{\text{SAMPLE}}$ is the external clock rate when <i>MSC_CTRL[3:2]</i> ≠ 00

**Table 33. Y\_DELT\_VEL (Base Address = 0x2C), Read Only**

Bits	Description
[15:0]	Y-axis, delta velocity output data 0° = 0x0000, twos complement format 1 LSB = $K_A \times 10 \times (\text{DEC\_RATE} + 1) / f_{\text{SAMPLE}}$ (mm/sec) $f_{\text{SAMPLE}} = 2048 \text{ Hz}$ when <i>MSC_CTRL[3:2]</i> = 00 $f_{\text{SAMPLE}}$ is the external clock rate when <i>MSC_CTRL[3:2]</i> ≠ 00

**Table 34. Z\_DELT\_VEL (Base Address = 0x2E), Read Only**

Bits	Description
[15:0]	Z-axis, delta velocity output data 0° = 0x0000, twos complement format 1 LSB = $K_A \times 10 \times (\text{DEC\_RATE} + 1) / f_{\text{SAMPLE}}$ (mm/sec) $f_{\text{SAMPLE}} = 2048 \text{ Hz}$ when <i>MSC_CTRL[3:2]</i> = 00 $f_{\text{SAMPLE}}$ is the external clock rate when <i>MSC_CTRL[3:2]</i> ≠ 00

Table 35 illustrates the delta velocity data format with numerical examples when *MSC\_CTRL[3:2]* = 00 ( $f_{\text{SAMPLE}} = 2048 \text{ Hz}$ ) and *DEC\_RATE* = 0x0000.

**Table 35. x\_DELT\_VEL Data Format, Example 1**

Velocity (mm/sec)	Decimal	Hex	Binary
+39.999	+32,767	0x7FFF	0111 1111 1111 1111
+0.0024414	+2	0x0002	0000 0000 0000 0010
+0.0012207	+1	0x0001	0000 0000 0000 0001
0	0	0x0000	0000 0000 0000 0000
-0.0012207	-1	0xFFFF	1111 1111 1111 1111
-0.0024414	-2	0xFFFE	1111 1111 1111 1110
-40	-32,768	0x8000	1000 0000 0000 0000

<sup>1</sup> *MSC\_CTRL[3:2]* = 00, *DEC\_RATE* = 0x0000.

Table 36 illustrates the delta velocity data format with numerical examples when MSC\_CTRL[3:2] = 01, the external clock ( $f_{\text{SAMPLE}}$ ) is 2000 Hz and DEC\_RATE = 0x0009.

**Table 36. x\_DELT\_VEL Data Format, Example 2**

Velocity (mm/sec)	Decimal	Hex	Binary
+409.59	+32,767	0x7FFF	0111 1111 1111 1111
+0.0250	+2	0x0002	0000 0000 0000 0010
+0.0125	+1	0x0001	0000 0000 0000 0001
0	0	0x0000	0000 0000 0000 0000
-0.0125	-1	0xFFFF	1111 1111 1111 1111
-0.0250	-2	0xFFFE	1111 1111 1111 1110
-409.6	-32,768	0x8000	1000 0000 0000 0000

<sup>1</sup>MSC\_CTRL[3:2] = 01, DEC\_RATE = 0x0009,  $f_{\text{SAMPLE}}$  = 2000 Hz.

## INTERNAL TEMPERATURE

The internal temperature measurement data loads into the TEMP\_OUT register (see Table 37). Table 38 illustrates the temperature data format. Note that this temperature represents an internal temperature reading, which does not precisely represent external conditions. The intended use of TEMP\_OUT is to monitor relative changes in temperature.

**Table 37. TEMP\_OUT (Base Address = 0x1E), Read Only**

Bits	Description
[15:0]	Twos complement, 0.05°C/LSB, 25°C = 0x0000

**Table 38. Temperature, Twos Complement Format**

Temperature (°C)	Decimal	Hex	Binary
+105	+1600	0x0640	0000 0110 0100 0000
+85	+1200	0x04B0	0000 0100 1011 0000
+25.1	+2	0x0002	0000 0000 0000 0010
+25.05	+1	0x0001	0000 0000 0000 0001
+25	0	0x0000	0000 0000 0000 0000
+24.95	-1	0xFFFF	1111 1111 1111 1111
+24.90	-2	0xFFFE	1111 1111 1111 1110
-40	-1300	0xFAEC	1111 1010 1110 1100

## PRODUCT IDENTIFICATION

The PROD\_ID register contains the binary equivalent of 16,460 (see Table 41). It provides a product specific variable for systems that need to track this in their system software. The LOT\_ID1 and LOT\_ID2 registers, respectively, combine to provide a unique, 32-bit lot identification code (see Table 39 and Table 40).

The SERIAL\_NUM register contains a binary number that represents the serial number on the device label (see Table 42). The assigned serial numbers in SERIAL\_NUM are lot specific.

**Table 39. LOT\_ID1 (Base Address = 0x52), Read Only**

Bits	Description
[15:0]	Lot identification, binary code

**Table 40. LOT\_ID2 (Base Address = 0x54), Read Only**

Bits	Description
[15:0]	Lot identification, binary code

**Table 41. PROD\_ID (Base Address = 0x56), Read Only**

Bits	Description (Default = 0x404C)
[15:0]	Product identification = 0x404C (16,460)

**Table 42. SERIAL\_NUM (Base Address = 0x58), Read Only**

Bits	Description
[15:12]	Reserved, values can vary
[11:0]	Serial number, 1 to 4094 (0xFFE)

## STATUS/ERROR FLAGS

The DIAG\_STAT register in Table 43 contains various bits that serve as error flags for flash update, communication, overrange, self test, and memory integrity. Reading this register provides access to the status of each flag and resets all bits to zero for monitoring future operation. If the error condition remains, the error flag returns to 1 at the conclusion of the next sample cycle.

**Table 43. DIAG\_STAT (Base Address = 0x02), Read Only**

Bits	Description (Default = 0x0000)
[15:8]	Not used, always zero
[9:8]	Reserved, values can vary (not always zero)
7	Input clock out of sync 1 = fail, 0 = pass
6	Flash memory test 1 = fail, 0 = pass
5	Self test diagnostic error flag 1 = fail, 0 = pass
4	Sensor overrange 1 = overrange, 0 = normal
3	SPI communication failure 1 = fail, 0 = pass
2	Flash update failure 1 = fail, 0 = pass
[1:0]	Not used, always zero

### Manual Flash Update

Setting GLOB\_CMD[3] = 1 (DIN = 0xBE08, see Table 44) triggers a manual flash update (MFU) routine, which copies the user register settings into manual flash memory, which provides a nonvolatile backup that loads into the registers during the reset or power-on process. After this routine completes, DIAG\_STAT[2] contains the pass/fail result. When this bit is set in an error state (equal to 1), trigger another MFU and check DIAG\_STAT[2] again after the MFU completes. If this flag remains at zero, it indicates that the latest attempt was completed and that no further action is necessary. Persistence in this error flag can indicate a failure in the flash memory.

**SPI Communication Failure**

This flag (DIAG\_STAT[3]) indicates that the total number of SCLK pulses was not equal to an integer multiple of 16, while the chip select (CS) line was low. This flag can be an indication of communication failure; therefore, it can trigger a process of repeating previous commands or a validation of data integrity.

**Sensor Overrange**

This error flag (DIAG\_STAT[4]) indicates that one of the inertial sensors has experienced a condition that exceeds its measurement range.

**Self Test Failure**

The DIAG\_STAT[5] bit provides the result from the automated self test function, which is associated with GLOB\_CMD[2] (see Table 44). When this bit is set in an error state (equal to 1), trigger

another automated self test (AST) and check DIAG\_STAT[5] again after the AST completes. If this flag remains at zero, it indicates that the latest attempt was completed and that no further action is necessary. Persistence in this error flag can indicate a failure in one or more of the inertial sensors.

**Flash Test Failure**

DIAG\_STAT[6] (see Table 43) contains the result of the memory test, which executes after setting GLOB\_CMD[4] = 1 (DIN = 0xBE10, see Table 44).

**Input Clock Sync Failure**

This error flag (DIAG\_STAT[7] = 1) indicates that the SYNC\_SCAL value is not appropriate for the frequency of the signal on the SYNC pin.

## SYSTEM FUNCTIONS

### GLOBAL COMMANDS

The GLOB\_CMD register provides trigger bits for a number of global commands. To start any of these routines, set the appropriate bit equal to 1 and then wait for the execution time (see Table 44) before initiating any further communication on the SPI port.

**Table 44. GLOB\_CMD (Base Address = 0x3E), Write Only**

Bits	Description	Execution Time (Max)
[15:8]	Not used	Not applicable
7	Software reset	222 ms
[6:5]	Not used	Not applicable
4	Flash memory test	36
3	Manual flash update	70
2	Automated self test (AST)	7
1	Factory calibration restore	75 ms
0	Gyroscope bias correction	1 output data cycle <sup>1</sup>

<sup>1</sup> DEC\_RATE (see Table 53) and MSC\_CTRL[3:2] (see Table 50) establish this time.

### SOFTWARE RESET

The GLOB\_CMD register provides an opportunity to initiate a processor reset by setting GLOB\_CMD[7] = 1 (DIN = 0xBE80).

### FLASH MEMORY TEST

The factory configuration of the ADIS16460 includes performing a cyclical redundancy check (CRC), using the IEEE-802.3 CRC32 Ethernet standard method, on the program code and calibration memory banks. This process establishes signature values for these two memory banks and programs them into the following registers: CODE\_SGNTR (see Table 45) and CAL\_SGNTR (see Table 46).

**Table 45. CODE\_SGNTR (Base Address = 0x64), Read Only**

Bits	Description
[15:0]	Program code signature value, constant

**Table 46. CAL\_SNGTR (Base Address = 0x60), Read Only**

Bits	Description
[15:0]	Calibration signature value, constant

The GLOB\_CMD register provides an opportunity to initiate a flash memory test at any time by setting GLOB\_CMD[4] = 1 (DIN = 0xBE10, see Table 44). This test performs the same CRC process on the program code and calibration memory banks and then writes the results into the following registers: CODE\_CRC (see Table 47) and CAL\_CRC (see Table 48). At the conclusion of this test, the pass/fail result loads into DIAG\_STAT[6] (see Table 43), with the passing result (DIAG\_STAT[6] = 0) requiring the following conditions:

- CODE\_CRC = CODE\_SGNTR
- CAL\_CRC = CAL\_SGNTR

**Table 47. CODE\_CRC (Base Address = 0x66), Read Only**

Bits	Description
[15:0]	Program code CRC, updates continuously

**Table 48. CAL\_CRC (Base Address = 0x62), Read Only**

Bits	Description
[15:0]	Calibration CRC value, updates continuously

### MANUAL FLASH UPDATE

The GLOB\_CMD register provides an opportunity to store user configuration values in nonvolatile flash by setting GLOB\_CMD[3] = 1 (DIN = 0xBE08, also see Figure 24). The FLASH\_CNT register (see Table 49) provides a running count of the number of flash updates to help users manage the endurance ratings (see Table 1). Note that initiating the commands in GLOB\_CMD[0] and GLOB\_CMD[1] (see Table 44) also includes a flash memory update, which results in an incremental count increase in the FLASH\_CNT register.

**Table 49. FLASH\_CNT (Base Address = 0x00), Read Only**

Bits	Description
[15:0]	Binary counter

### AUTOMATED SELF TEST

Each inertial sensor in the ADIS16460 has a self test function that applies an electrostatic force to its physical elements, which causes them to move in a manner that simulates their response to rotational (gyroscope) and linear (accelerometer) motion. This movement causes a predictable, observable response on the output of each sensor, which provides an opportunity to verify basic functionality of each sensor and their associated signal chain. The GLOB\_CMD register provides an opportunity to initiate an automated process that uses this sensor level feature to verify that each sensor is in working order. Set GLOB\_CMD[2] = 1 (DIN = 0xBE04, see Table 44) to trigger this AST function, which stops normal data production, exercises the self test function of each sensor, compares their responses to the range of normal responses, and then restores normal data sampling. After this routine completes, the DIAG\_STAT[5] (see Table 43) contains the pass/fail result.

### INPUT/OUTPUT CONFIGURATION

The ADIS16460 provides two pins, SYNC and DR, that manage sampling and data collection (see Figure 5). The MSC\_CTRL register provides several bits for configuring these pins (see Table 50).

### DATA READY (DR) PIN CONFIGURATION

The DR pin provides a data ready signal that indicates when new data is available in the output registers, which helps minimize processing latency and avoid data collision (see Figure 5). Figure 17 shows an example, where this pin connects to an interrupt request (IRQ) pin on the system processor. Use MSC\_CTRL[0] (see Table 50) to establish a polarity so that system level interrupt service routines (ISR) can trigger on the appropriate edge of this signal. For example, Figure 4 illustrates an example where MSC\_CTRL[0] = 1, which works well with

IRQ pins that trigger on the positive edge of a pulse. When DR is driving an IRQ pin that triggers on the negative edge of a signal, set DIN = 0xB2C3 (MSC\_CTRL[7:0] = 0xC3). This code also preserves the factory default configuration for the linear g compensation (MSC\_CTRL[7]) and point of percussion (MSC\_CTRL[6]). Note that the data ready signal stops while the device executes the global commands associated with the GLOB\_CMD register (see Table 44).

**SYNC PIN CONFIGURATION**

MSC\_CTRL[3:2] (see Table 50) provides user configurable controls for selecting one of four modes that the SYNC pin/function (see Figure 5) supports: internal sample clock, external sync (direct sample control), precision input sync with data counter, and sample time indicator. MSC\_CTRL[1] establishes the polarity for the active state of the SYNC pin, regardless of the mode it is operating in.

**Table 50. MSC\_CTRL (Base Address = 0x32), Read/Write**

Bits	Description (Default = 0x00C1)
[15:7]	Not used
7	Linear-g compensation control 1 = enabled 0 = disabled (no linear-g compensation)
6	Point of percussion, see Figure 32 1 = enabled 0 = disabled (no point of percussion alignment)
[5:4]	Not used, always set to zero
[3:2]	SYNC function setting 11 = sample time indicator (output) 10 = precision input sync with data counter 01 = direct sample control (input) 00 = disabled (internal sample clock)
1	SYNC polarity (input or output) 1 = rising edge triggers sampling 0 = falling edge triggers sampling
0	DR polarity 1 = active high when data is valid 0 = active low when data is valid

**Sample Time Indicator**

When MSC\_CTRL[3:2] = 11 (see Table 50), the ADIS16460 sampled and processes data using its internal sample clock (2048 SPS) and the SYNC pin provides a pulsing signal, whose leading edge indicates the sample time of the inertial sensors. Set DIN = 0xB2CD to configure the ADIS16460 for this mode, while preserving the rest of the default settings in the MSC\_CTRL register.

**Precision Input Sync with Data Counter**

When MSC\_CTRL[3:2] = 10 (see Table 50), the update rate in the output registers is equal to the product of the input clock frequency (f<sub>SYNC</sub>) and the scale factor (H<sub>SS</sub>) in the SYNC\_SCAL (see Table 51) register. This mode provides support for slower input clock references, such as the pulse per second (PPS) from

some global positioning systems (GPS) or some video synchronizing signals. Set DIN = 0xB2C9 to configure the ADIS16460 for this mode, while preserving the rest of the default settings in the MSC\_CTRL register. When in this mode, use the following formula to calculate the scale factor (H<sub>SS</sub>) value to write into the SYNC\_SCAL register:

$$H_{SS} = \text{floor}\left(\frac{32,768}{f_{SYNC}} - 1\right)$$

For example, when using a 60 Hz video sync signal, set H<sub>SS</sub> equal to 545 (SYNC\_SCAL = 0x0221) by setting DIN = 0xB421 and 0xB502.

$$H_{SS} = \text{floor}\left(\frac{32,768}{60} - 1\right) = \text{floor}(545.13333) = 545$$

When using a 1 Hz PPS signal, the default value of this register (0x7FFF) supports this mode. If SYNC\_SCAL does not have its default contents, set SYNC\_SCAL = 0x7FFF by setting DIN = 0xB4FF and 0xB57E.

$$H_{SS} = \text{floor}\left(\frac{32,768}{1} - 1\right) = \text{floor}(32,767) = 32,767$$

Make sure to adhere to the following relationship when establishing the nominal value for f<sub>SYNC</sub>.

$$1945 \text{ Hz} \leq H_{SS} \times f_{SYNC} \leq 2048$$

When operating outside of this condition, the input control loop for the data sampling can lose its lock on the input frequency. DIAG\_STAT[7] = 1 (see Table 43) provides an indication of this condition, where the input sync signal is no longer influencing the sample times.

**Table 51. SYNC\_SCAL (Base Address = 0x34), Read/Write**

Bits	Description (Default = 0x7FFF)
15	Not used
[14:0]	Input sync scale factor, H <sub>SS</sub> , when MSC_CTRL[3:2] = 10. Binary format, range = 255 to 32,767.

When MSC\_CTRL[3:2] = 10, the SMPL\_CNTR register provides a total number of counts that occurs after each input clock pulse using a rate of 24576 Hz. The SMPL\_CNTR register resets to 0x0000 with the leading edge of each sync input signal.

**Table 52. SMPL\_CNTR (Base Address = 0x1C), Read/Write**

Bits	Description
[15:0]	Data counter for the number of samples since the last input clock pulse, binary format, 0x0000 = 0 μs, 40.69 μs/LSB, each input clock pulse resets this value to 0x0000

**Direct Sample Control**

When MSC\_CTRL[3:2] = 01 (see Table 50), the clock signal on the SYNC pin controls the update rate in the output registers. Set DIN = 0xB2C5 to configure the ADIS16460 for this mode, while preserving the rest of the default settings in the MSC\_CTRL register.

## DIGITAL PROCESSING CONFIGURATION GYROSCOPES/ACCELEROMETERS

Figure 30 provides a diagram that describes the entire signal processing for the gyroscopes and accelerometers. When using the internal sample clock, (MSC\_CTRL[3:2] = 00, see Table 50), the internal sampling system produces new data at a rate of 2048 SPS. The DEC\_RATE register (see Table 53) provides a user configurable input, which controls the decimation rate for the update rate in the output registers. For example, set DEC\_RATE = 0x0009 (DIN = 0xB609, then DIN = 0xB700) to set the decimation factor to 10. This setting reduces the update rate to 204.8 SPS and affects the update rate in the gyroscope, accelerometer, and temperature output registers.

Table 53. DEC\_RATE (Base Address = 0x36), Read/Write

Bits	Description (Default = 0x0000)
[15:11]	Not used, always zero
[10:0]	D, decimation rate setting, linear, see Figure 30

### Digital Filtering

The FLTR\_CTRL register (see Table 54) provides user controls for the digital low-pass filter. This filter contains two cascaded averaging filters that provide a Bartlett window, FIR filter response (see Figure 29). For example, set FLTR\_CTRL[2:0] = 100 (DIN = 0xB804) to set each stage to 16 taps. When used with the default sample rate of 2048 SPS and zero decimation DEC\_RATE = 0x00, this value reduces the sensor bandwidth to approximately 41 Hz.

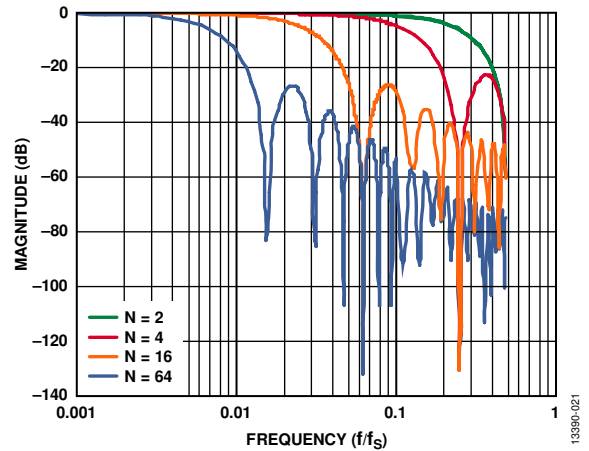

Figure 29. Bartlett Window, FIR Filter Frequency Response (Phase Delay = N Samples)

Table 54. FLTR\_CTRL (Base Address = 0x38), Read/Write

Bits	Description (Default = 0x0500)
[15:9]	Reserved
[10:8]	Sensor bias estimation time factor (NBE) Setting range = 0 to 6 Estimation time = $(1/2048) \times 2^{(NBE + 11)}$ (seconds)
[7:3]	Reserved
[2:0]	Filter Size Variable B, setting range = 0 to 6 Number of taps in each stage; $N_B = 2^B$ See Figure 29 for the filter response

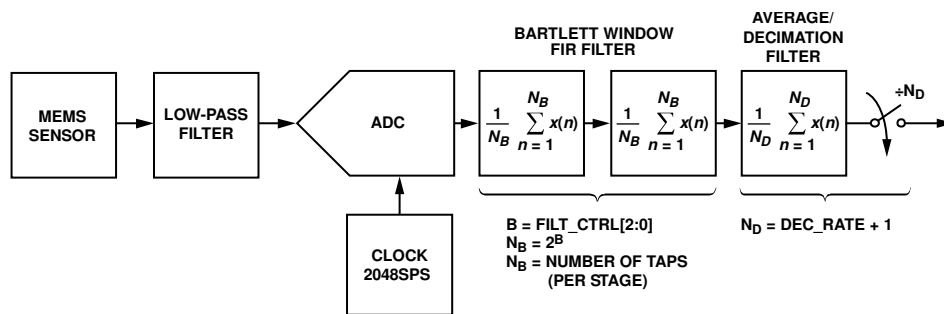

Figure 30. Sensor Sampling and Frequency Response Block Diagram

## CALIBRATION

The mechanical structure and assembly process of the ADIS16460 provide excellent position and alignment stability for each sensor, even after subjected to temperature cycles, shock, vibration, and other environmental conditions. The factory calibration includes a dynamic characterization of each gyroscope and accelerometer over temperature, and generates sensor specific correction formulas.

### GYROSCOPES

The X\_GYRO\_OFF (see Table 55), Y\_GYRO\_OFF (see Table 56), and Z\_GYRO\_OFF (see Table 57) registers provide user-programmable bias adjustment function for the x-axis, y-axis, and z-axis gyroscopes, respectively. Figure 31 illustrates that the bias correction factors in each of these registers has a direct impact on the data in output registers of each sensor.

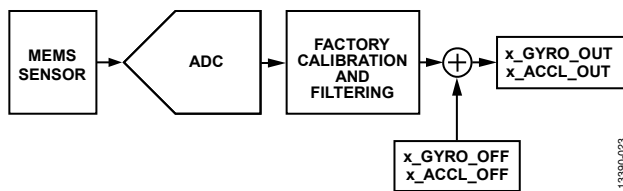

Figure 31. User Calibration, Gyroscopes, and Accelerometers

Table 55. X\_GYRO\_OFF (Base Address = 0x40), Read/Write

Bits	Description (Default = 0x0000)
[15:0]	X-axis, gyroscope offset correction factor, twos complement, 1 LSB = 0.000625°/sec, 0°/sec = 0x0000

Table 56. Y\_GYRO\_OFF (Base Address = 0x42), Read/Write

Bits	Description (Default = 0x0000)
[15:0]	Y-axis, gyroscope offset correction factor, twos complement, 1 LSB = 0.000625°/sec, 0°/sec = 0x0000

Table 57. Z\_GYRO\_OFF (Base Address = 0x44), Read/Write

Bits	Description (Default = 0x0000)
[15:0]	Z-axis, gyroscope offset correction factor, twos complement, 1 LSB = 0.000625°/sec, 0°/sec = 0x0000

### Gyroscope Bias Error Estimation

Any system level calibration function must start with an estimate of the bias errors. Estimating the bias error typically involves collecting and averaging a time record of gyroscope data while the ADIS16460 is operating through static inertial conditions. The length of the time record associated with this estimate depends on the accuracy goals. The Allan Variance relationship (see Figure 7) provides a trade-off relationship between the averaging time and the expected accuracy of a bias measurement. Vibration, thermal gradients, and power supply instability can influence the accuracy of this process.

### Gyroscope Bias Correction Factors

When the bias estimate is complete, multiply the estimate by -1 to change its polarity, convert it into digital format for the offset correction registers (see Table 55, Table 56, and Table 57), and write the correction factors to the correction registers. For

example, lower the x-axis bias by 10 LSB (0.00625°/sec) by setting X\_GYRO\_OFF = 0xFF6 (DIN = 0xC1FF, 0xC0F6).

### Single Command Bias Correction

Setting GLOB\_CMD[0] = 1 (DIN = 0xBE01, see Table 44) causes the ADIS16460 to automatically load the X\_GYRO\_OFF, Y\_GYRO\_OFF, and Z\_GYRO\_OFF registers with the values from a backward looking, continuous bias estimator (CBE). The record length/time for the CBE is associated with the FLTR\_CTRL[10:8] bits (see Table 54). The accuracy of this estimate relies on ensuring no rotational motion during the estimation time in FLTR\_CTRL[10:8].

### ACCELEROMETERS

The X\_ACCL\_OFF (see Table 58), Y\_ACCL\_OFF (see Table 59), and Z\_ACCL\_OFF (see Table 60) registers provide user programmable bias adjustment function for the x-axis, y-axis, and z-axis accelerometers, respectively. Figure 31 illustrates that the bias correction factors in each of these registers has a direct impact on the data in each sensor's output registers.

Table 58. X\_ACCL\_OFF (Base Address = 0x46), Read/Write

Bits	Description (Default = 0x0000)
[15:0]	X-axis, accelerometer offset correction factor, twos complement, 0.03125 mg/LSB, 0 g = 0x0000

Table 59. Y\_ACCL\_OFF (Base Address = 0x48), Read/Write

Bits	Description (Default = 0x0000)
[15:14]	Not used
[13:0]	Y-axis, accelerometer offset correction factor, twos complement, 0.03125 mg/LSB, 0 g = 0x0000

Table 60. Z\_ACCL\_OFF (Base Address = 0x4A), Read/Write

Bits	Description (Default = 0x0000)
[15:14]	Not used
[13:0]	Z-axis, accelerometer offset correction factor, twos complement, 0.03125 mg/LSB, 0 g = 0x0000

### Accelerometer Bias Error Estimation

Under static conditions, orient each accelerometer in positions where the response to gravity is predictable. A common approach is to measure the response of each accelerometer when they are oriented in peak response positions, that is, where ±1 g is the ideal measurement position. Next, average the +1 g and -1 g accelerometer measurements together to estimate the residual bias error. Using more points in the rotation can improve the accuracy of the response.

### Accelerometer Bias Correction Factors

When the bias estimate is complete, multiply the estimate by -1 to change its polarity, convert it to the digital format for the offset correction registers (see Table 58, Table 59, or Table 60), and write the correction factors to the correction registers. For example, lower the y-axis bias by 12 LSB (0.375 mg) by setting Y\_ACCL\_OFF = 0xFF4 (DIN = 0xC7FF, 0xC6F4).



**Point of Percussion Alignment**

Set `MSC_CTRL[6] = 1` (`DIN = 0xB2C1`, see Table 50) to enable this feature and maintain the factory default settings for the DR and SYNC pins. This feature performs a point of percussion translation to the point identified in Figure 32. See Table 50 for more information on `MSC_CTRL`.

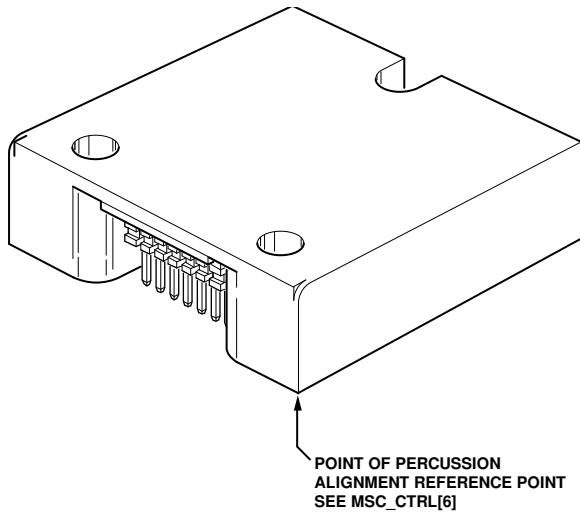

Figure 32. Point of Percussion Physical Reference

**RESTORING FACTORY CALIBRATION**

Set `GLOB_CMD[1] = 1` (`DIN = 0xBE02`, see Table 44) to execute the factory calibration restore function, which resets the gyroscope and accelerometer offset registers to `0x0000` and all sensor data to 0. This process concludes by automatically updating the flash memory and then returns to normal data sampling and processing.

# APPLICATIONS INFORMATION

## MOUNTING TIPS

The ADIS16460 package supports installation onto a printed circuit board (PCB) or rigid enclosure, using three M2 or 2-56 machine screws, using a torque that is between 20 inch ounces and 40 inch ounces. When designing a mechanical interface for the ADIS16460, avoid placing unnecessary translational stress on the electrical connector because it can influence the bias repeatability behaviors of the inertial sensors. When the same PCB also has the mating connector, the use of passthrough holes for the mounting screws may be required. Figure 33 shows a detailed view of the PCB pad design when using one of the connector variants in the CLM-107-02 family.

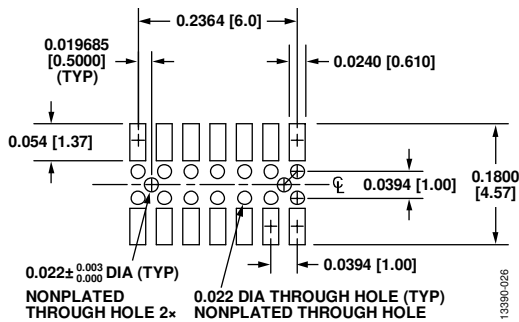

Figure 33. Mating Connector Design Detail

## POWER SUPPLY CONSIDERATIONS

During startup, the internal power conversion system starts drawing current when VDD reaches 1.6 V. The internal processor begins initializing when VDD is equal to 2.35 V. After the processor starts, VDD must reach 2.7 V within 128 ms. Also, make sure that the power supply drops below 1.6 V to ensure that the internal processor shuts down. Use at least 10 μF of capacitance across VDD and GND. Best results come from using high quality, multilayer ceramic capacitors, located as close to the ADIS16460 connector as is practical. Using this capacitor supports optimal noise performance in the sensors.

## BREAKOUT BOARD

The ADIS16IMU4/PCBZ breakout board provides a ribbon cable interface for simple connection to an embedded processor development system. Figure 34 shows the electrical schematic, and Figure 35 shows a top view for this breakout board. J2 mates directly to the electrical connector on the ADIS16460, and J1 easily mates to a 1 mm ribbon cable system.

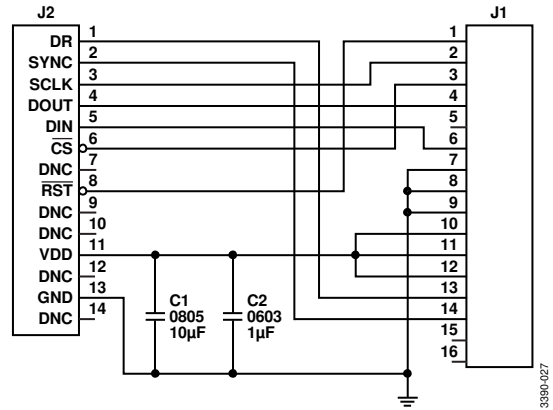

Figure 34. ADIS16IMU4/PCBZ Electrical Schematic

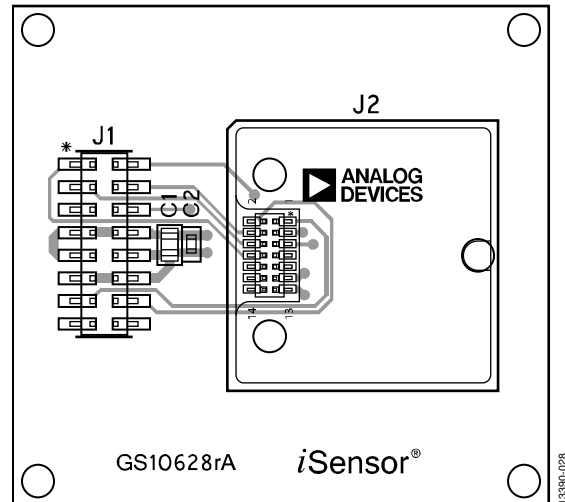

Figure 35. ADIS16IMU4/PCBZ Top View

J1			
RST	1	2	SCLK
CS	3	4	DOUT
DNC	5	6	DIN
GND	7	8	GND
GND	9	10	VDD
VDD	11	12	VDD
DR	13	14	SYNC
NC	15	16	NC

Figure 36. ADIS16IMU4/PCBZ J1 Pin Assignments