



Chipsmall Limited consists of a professional team with an average of over 10 year of expertise in the distribution of electronic components. Based in Hongkong, we have already established firm and mutual-benefit business relationships with customers from,Europe,America and south Asia,supplying obsolete and hard-to-find components to meet their specific needs.

With the principle of “Quality Parts,Customers Priority,Honest Operation,and Considerate Service”,our business mainly focus on the distribution of electronic components. Line cards we deal with include Microchip,ALPS,ROHM,Xilinx,Pulse,ON,Everlight and Freescale. Main products comprise IC,Modules,Potentiometer,IC Socket,Relay,Connector.Our parts cover such applications as commercial,industrial, and automotives areas.

We are looking forward to setting up business relationship with you and hope to provide you with the best service and solution. Let us make a better world for our industry!



Contact us

Tel: +86-755-8981 8866 Fax: +86-755-8427 6832

Email & Skype: info@chipsmall.com Web: www.chipsmall.com

Address: A1208, Overseas Decoration Building, #122 Zhenhua RD., Futian, Shenzhen, China



ADJD-S311-CR999

Miniature Surface Mount RGB Digital Color Sensor



Data Sheet



Description

The ADJD-S311-CR999 is a cost effective, 4 channels (RGB+CLEAR) digital output sensor in miniature surface-mount package with a mere size of 2.2 x 2.2 x 0.76mm. It is a CMOS IC with integrated RGB filters and analog-to-digital converter front end. This device is designed to cater for wide dynamic range of illumination level and is ideal for applications like portable or mobile devices, which demand higher integration, smaller size and low power consumption. Sensitivity control is performed by the serial interface and can be optimized individually for the different color channel. The sensor can also be used in conjunction with a white LED for reflective color management.

Applications

- General color detection and measurement
- Mobile appliances such as mobile phones, PDAs, MP3 players, etc.
- Consumer appliances
- Portable medical equipments
- Portable color detector/reader

Features

- Fully integrated RGB+clear digital color sensor
- 10 bit resolution per channel output
- Built in oscillator/selectable external clock
- Low supply voltage (VDD) 2.5V
- Digital I/O via 2-wire serial interface
- Adjustable sensitivity for different levels of illumination
- Low power mode (sleep mode)
- Independent gain selection for each channel
- 0°C to 70°C operating temperature
- Industry's smallest form factor
 - CSP 2.2 x 2.2 x 0.76mm
- Lead free package

General Specifications

| Feature | Value |
|-----------|---|
| Interface | 100kHz serial interface |
| Supply | 2.6V digital (nominal), 2.6V analog (nominal) |

Powering the Device

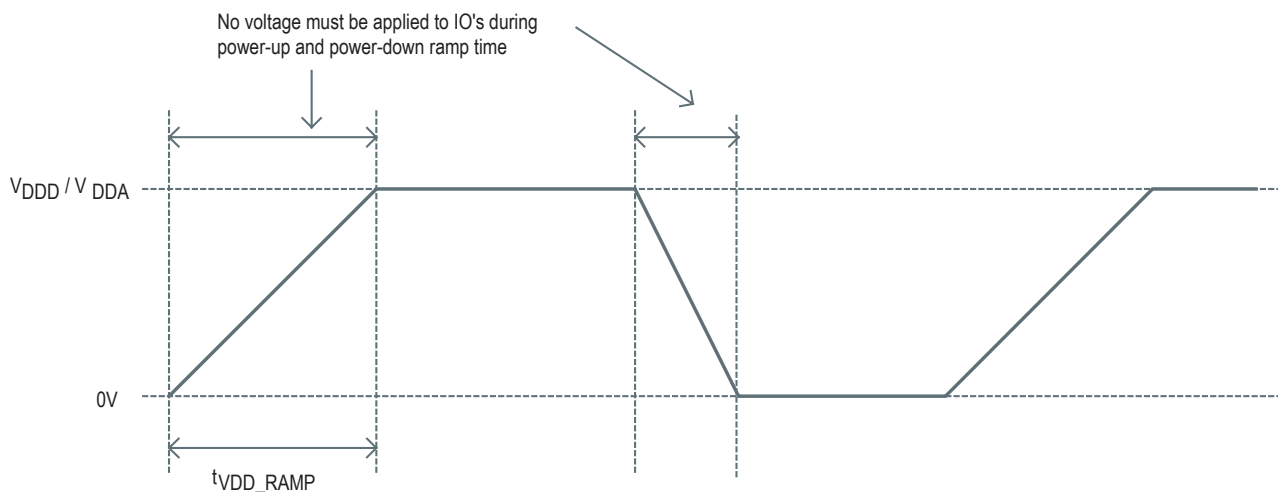

ESD Protection Diode Turn-On During Power-Up and Power-Down

A particular power-up and power-down sequence must be used to prevent any ESD diode from turning on inadvertently. The figure above describes the sequence. In general, AVDD and DVDD should power-up and power-down together to prevent ESD diodes from turning on inadvertently. During this period, no voltage should be applied to the IO's for the same reason.

Ground Connection

AGND and DGND must both be set to 0V and preferably star-connected to a central power source as shown in the application diagram. A potential difference between AGND and DGND may cause the ESD diodes to turn on inadvertently.

Electrical Specifications

Absolute Maximum Ratings (Notes 1 & 2)

| Parameter | Symbol | Minimum | Maximum | Units | Notes |
|--------------------------------------|------------------|---------|---------|-------|--|
| Storage temperature | T_{STG_ABS} | -40 | 85 | °C | |
| Digital supply voltage, DVDD to DVSS | V_{DD_ABS} | 2.5 | 3.6 | V | |
| Analog supply voltage, AVDD to AVSS | V_{DDA_ABS} | 2.5 | 3.6 | V | |
| Input voltage | V_{IN_ABS} | 2.5 | 3.6 | V | All I/O pins |
| Solder Reflow Peak temperature | T_{L_ABS} | | 245 | °C | |
| Human Body Model ESD rating | ESD_{HBM_ABS} | | 2 | kV | All pins, human body model per JESD22-A114-B |

Recommended Operating Conditions

| Parameter | Symbol | Minimum | Typical | Maximum | Units |
|--------------------------------------|-----------|--------------|---------|--------------|-------|
| Free air operating temperature | T_A | 0 | 25 | 70 | °C |
| Digital supply voltage, DVDD to DVSS | V_{DDD} | 2.5 | 2.6 | 3.6 | V |
| Analog supply voltage, AVDD to AVSS | V_{DDA} | 2.5 | 2.6 | 3.6 | V |
| Output current load high | I_{OH} | | | 3 | mA |
| Output current load low | I_{OL} | | | 3 | mA |
| Input voltage high level (Note 4) | V_{IH} | $0.7V_{DDD}$ | | V_{DDD} | V |
| Input voltage low level (Note 4) | V_{IL} | 0 | | $0.3V_{DDD}$ | V |

DC Electrical Specifications

Over Recommended Operating Conditions (unless otherwise specified)

| Parameter | Symbol | Conditions | Minimum | Typical (Note 3) | Maximum | Units |
|------------------------------------|------------------|-----------------------|---------------|------------------|---------|-------|
| Output voltage high level (Note 5) | V_{OH} | $I_{OH} = 3\text{mA}$ | $V_{DDD}-0.8$ | $V_{DDD}-0.4$ | | V |
| Output voltage low level (Note 6) | V_{OL} | $I_{OH} = 3\text{mA}$ | | 0.2 | 0.4 | V |
| Supply current (Note 7) | I_{DD_STATIC} | (Note 8) | | 3.8 | 5 | mA |
| Sleep-mode supply current (Note 7) | I_{DD_SLP} | (Note 8) | | 2 | | uA |
| Input leakage current | I_{LEAK} | | -10 | | 10 | uA |

AC Electrical Specifications

| Parameter | Symbol | Conditions | Minimum | Typical (Note 3) | Maximum | Units |
|----------------------------|----------------|------------|---------|------------------|---------|-------|
| Internal clock frequency | f_{CLK_int} | | | 26 | | MHz |
| External clock frequency | f_{CLK_ext} | | 16 | | 40 | MHz |
| 2-wire interface frequency | f_{2wire} | | | 100 | | kHz |

Optical Specification

| Parameter | Symbol | Conditions | Minimum | Typical (Note 3) | Maximum | Units |
|-------------|--------|------------|---------|------------------|---------|-------|
| Dark offset | V_D | $E_e = 0$ | | 20 | | LSB |

Minimum sensitivity (note 3)

| Parameter | Symbol | Conditions | Minimum | Typical (Note 3) | Maximum | Units |
|----------------------------|--------|--|---------|------------------|---------|---------------------------|
| Irradiance Responsivity | Re | $\lambda_p = 460$ nm, B Refer Note 9 | | 152 | | LSB/(mWcm ⁻²) |
| | | $\lambda_p = 542$ nm, G Refer Note 10 | | 178 | | |
| | | $\lambda_p = 645$ nm, R Refer Note 11 | | 254 | | |
| | | $\lambda_p = 645$ nm, Clear Refer Note 11 | | 264 | | |

Maximum sensitivity (note 3)

| Parameter | Symbol | Conditions | Minimum | Typical (Note 3) | Maximum | Units |
|----------------------------|--------|--|---------|------------------|---------|---------------------------|
| Irradiance Responsivity | Re | $\lambda_p = 460$ nm, B Refer Note 9 | | 3796 | | LSB/(mWcm ⁻²) |
| | | $\lambda_p = 542$ nm, G Refer Note 10 | | 4725 | | |
| | | $\lambda_p = 645$ nm, R Refer Note 11 | | 6288 | | |
| | | $\lambda_p = 645$ nm, Clear Refer Note 11 | | 6590 | | |

Saturation Irradiance for minimum sensitivity (note 12)

| Parameter | Symbol | Conditions | Minimum | Typical (Note 3) | Maximum | Units |
|--------------------------|--------|--|---------|------------------|---------|--------------------|
| Saturation Irradiance | | $\lambda_p = 460$ nm, B Refer Note 9 | | 6.73 | | mW/cm ² |
| | | $\lambda_p = 542$ nm, G Refer Note 10 | | 5.74 | | |
| | | $\lambda_p = 645$ nm, R Refer Note 11 | | 4.03 | | |
| | | $\lambda_p = 645$ nm, Clear Refer Note 11 | | 3.87 | | |

Saturation irradiance for maximum sensitivity (note 12)

| Parameter | Symbol | Conditions | Minimum | Typical (Note 3) | Maximum | Units |
|--------------------------|--------|--|---------|------------------|---------|--------------------|
| Saturation Irradiance | | $\lambda_p = 460$ nm, B Refer Note 9 | | 0.27 | | mW/cm ² |
| | | $\lambda_p = 542$ nm, G Refer Note 10 | | 0.22 | | |
| | | $\lambda_p = 645$ nm, R Refer Note 11 | | 0.16 | | |
| | | $\lambda_p = 645$ nm, Clear Refer Note 11 | | 0.16 | | |

Notes

1. The "Absolute Maximum Ratings" are those values beyond which damage to the device may occur. The device should not be operated at these limits. The parametric values defined in the "Electrical Specifications" table are not guaranteed at the absolute maximum ratings. The "Recommended Operating Conditions" table will define the conditions for actual device operation.
2. Unless otherwise specified, all voltages are referenced to ground.
3. Specified at room temperature (25°C) and $V_{DD} = V_{DDA} = 2.5V$.
4. Applies to all DI pins.
5. Applies to all digital output pins. SDASLV go tri-state when output logic high. Minimum V_{OH} depends on the pull-up resistor value.

Notes: (continued)

- 6. Applies to all digital output and digital input-output pins.
- 7. Refers to total device current consumption.
- 8. Output and bidirectional pins are not loaded.
- 9. Test condition is blue light of peak wavelength (λ_p) 460 nm and spectral half width ($\Delta\lambda_{1/2}$) 25 nm.
- 10. Test condition is green light of peak wavelength (λ_p) 542 nm and spectral half width ($\Delta\lambda_{1/2}$) 35 nm.
- 11. Test condition is red light of peak wavelength (λ_p) 645 nm and spectral half width ($\Delta\lambda_{1/2}$) 20 nm.
- 12. Saturation irradiance = (MSB)/ (Irradiance responsivity)

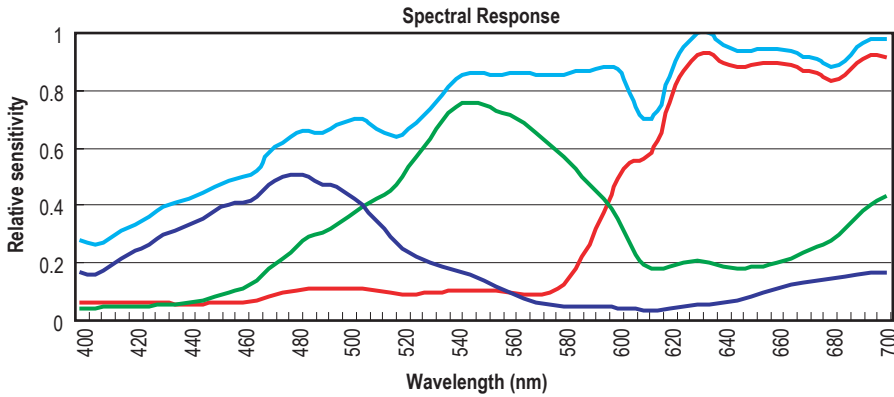

Figure 1. Typical spectral response when the gains for all the color channels are set at equal.

Serial Interface Timing Information

| Parameter | Symbol | Minimum | Maximum | Units |
|---|--------------|---------|---------|---------|
| SCL clock frequency | f_{scl} | 0 | 100 | kHz |
| (Repeated) START condition hold time | $t_{HD:STA}$ | 4 | - | μs |
| Data hold time | $t_{HD:DAT}$ | 0 | 3.45 | μs |
| SCL clock low period | t_{LOW} | 4.7 | - | μs |
| SCL clock high period | t_{HIGH} | 4.0 | - | μs |
| Repeated START condition setup time | $t_{SU:STA}$ | 4.7 | - | μs |
| Data setup time | $t_{SU:DAT}$ | 250 | - | ns |
| STOP condition setup time | $t_{SU:STO}$ | 4.0 | - | μs |
| Bus free time between START and STOP conditions | t_{BUF} | 4.7 | - | μs |

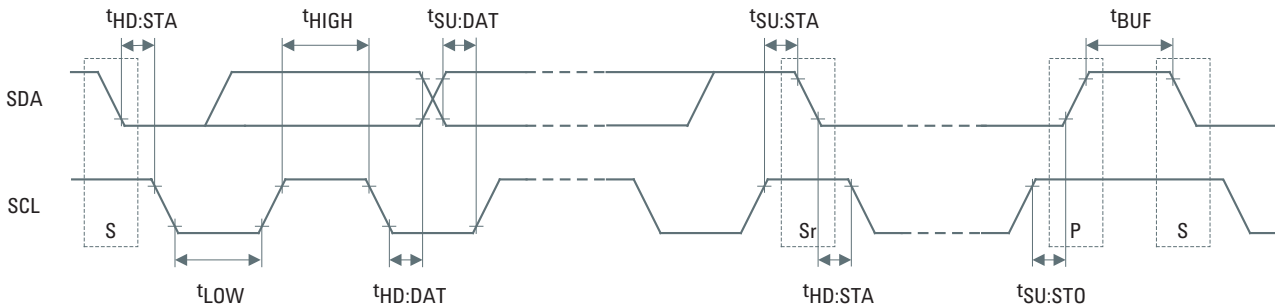

Figure 2. Serial Interface Bus Timing Waveforms

Serial Interface Reference

Description

The programming interface to the ADJD-S311 is a 2-wire serial bus. The bus consists of a serial clock (SCL) and a serial data (SDA) line. The SDA line is bi-directional on ADJD-S311 and must be connected through a pull-up resistor to the positive power supply. When the bus is free, both lines are HIGH.

The 2-wire serial bus on ADJD-S311 requires one device to act as a master while all other devices must be slaves. A master is a device that initiates a data transfer on the bus, generates the clock signal and terminates the data transfer while a device addressed by the master is called a slave. Slaves are identified by unique device addresses.

Both master and slave can act as a transmitter or a receiver but the master controls the direction for data transfer. A transmitter is a device that sends data to the bus and a receiver is a device that receives data from the bus.

The ADJD-S311 serial bus interface always operates as a slave transceiver with a data transfer rate of up to 100kbit/s.

START/STOP Condition

The master initiates and terminates all serial data transfers. To begin a serial data transfer, the master must send a unique signal to the bus called a START condition. This is defined as a HIGH to LOW transition on the SDA line while SCL is HIGH.

The master terminates the serial data transfer by sending another unique signal to the bus called a STOP condition. This is defined as a LOW to HIGH transition on the SDA line while SCL is HIGH.

The bus is considered to be busy after a START (S) condition. It will be considered free a certain time after the STOP (P) condition. The bus stays busy if a repeated START (Sr) is sent instead of a STOP condition.

The START and repeated START conditions are functionally identical. See figure 3.

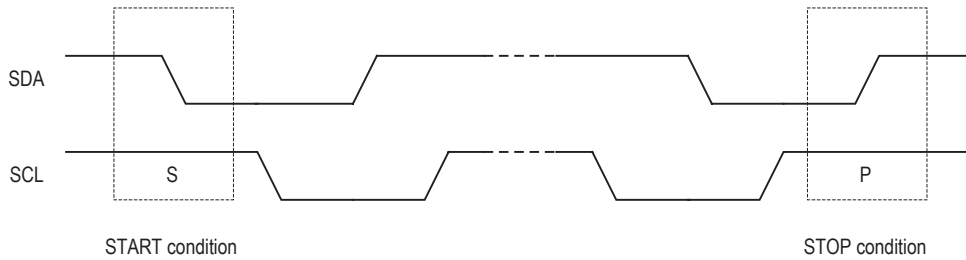

Figure 3. START/STOP Condition

Data Transfer

The master initiates data transfer after a START condition. Data is transferred in bits with the master generating one clock pulse for each bit sent. For a data bit to be valid, the SDA data line must be stable during the HIGH period of the SCL clock line. Only during the LOW period of the SCL clock line can the SDA data line change state to either HIGH or LOW.

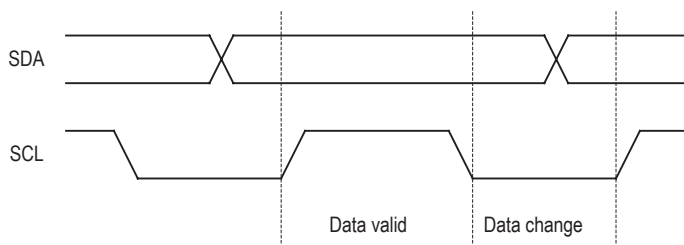

Figure 4. Data Bit Transfer

The SCL clock line synchronizes the serial data transmission on the SDA data line. It is always generated by the master. The frequency of the SCL clock line may vary throughout the transmission as long as it still meets the minimum timing requirements.

The master by default drives the SDA data line. The slave drives the SDA data line only when sending an acknowledge bit after the master writes data to the slave or when the master requests the slave to send data.

The SDA data line driven by the master may be implemented on the negative edge of the SCL clock line. The master may sample data driven by the slave on the positive edge of the SCL clock line. Figure 5 shows an example of a master implementation and how the SCL clock line and SDA data line can be synchronized.

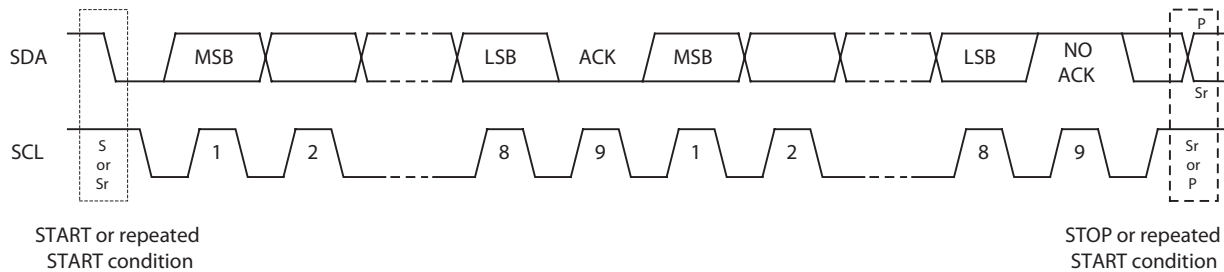

Figure 5. Data Byte Transfer

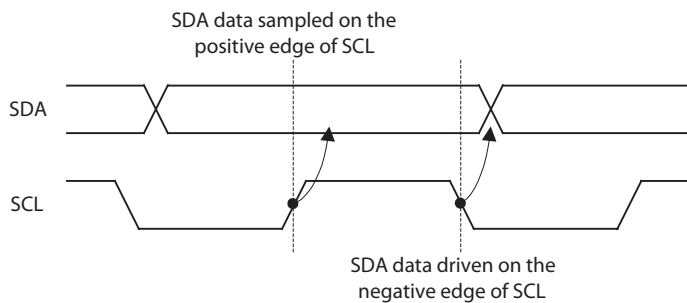

Figure 6. Data Bit Synchronization

A complete data transfer is 8-bits long or 1-byte. Each byte is sent most significant bit (MSB) first followed by an acknowledge or not acknowledge bit. Each data transfer can send an unlimited number of bytes (depending on the data format).

Acknowledge/Not acknowledge

The receiver must always acknowledge each byte sent in a data transfer. In the case of the slave-receiver and master-transmitter, if the slave-receiver does not send an acknowledge bit, the master-transmitter can either STOP the transfer or generate a repeated START to start a new transfer.

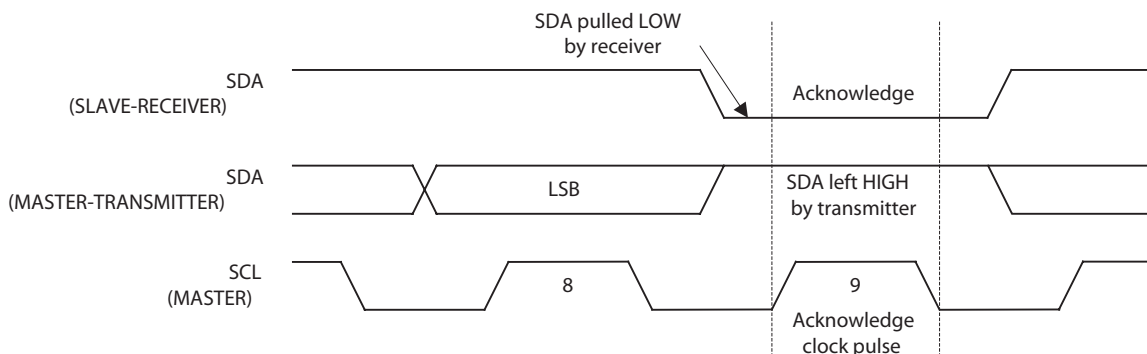

Figure 7. Slave-Receiver Acknowledge

In the case of the master-receiver and slave-transmitter, the master generates a not acknowledge to signal the end of the data transfer to the slave-transmitter. The master can then send a STOP or repeated START condition to begin a new data transfer.

In all cases, the master generates the acknowledge or not acknowledge SCL clock pulse.

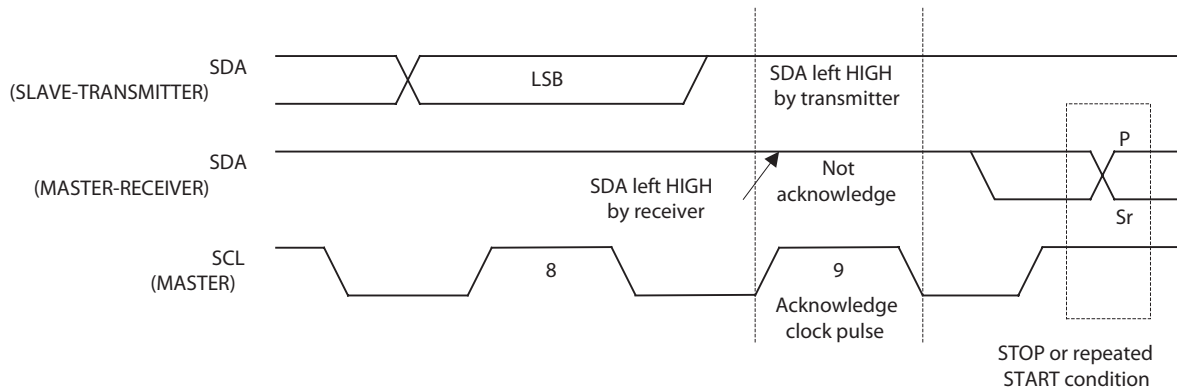

Figure 8. Master-Receiver Acknowledge

Addressing

Each slave device on the serial bus needs to have a unique address. This is the first byte that is sent by the master-transmitter after the START condition. The address is defined as the first seven bits of the first byte.

The eighth bit or least significant bit (LSB) determines the direction of data transfer. A 'one' in the LSB of the first byte indicates that the master will read data from the addressed slave (master-receiver and slave-transmitter). A 'zero' in this position indicates that the master will write data to the addressed slave (master-transmitter and slave-receiver).

A device whose address matches the address sent by the master will respond with an acknowledge for the first byte and set itself up as a slave-transmitter or slave-receiver depending on the LSB of the first byte.

The slave address on ADJD-S311 is 0x74 (7-bits).

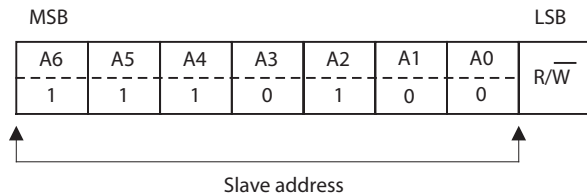

Figure 9. Slave Addressing

Data format

ADJD-S311 uses a register-based programming architecture. Each register has a unique address and controls a specific function inside the chip.

To write to a register, the master first generates a START condition. Then it sends the slave address for the device it wants to communicate with. The least significant bit (LSB) of the slave address must indicate that the master wants to write to the slave. The addressed device will then acknowledge the master.

The master writes the register address it wants to access and waits for the slave to acknowledge. The master then writes the new register data. Once the slave acknowledges, the master generates a STOP condition to end the data transfer.

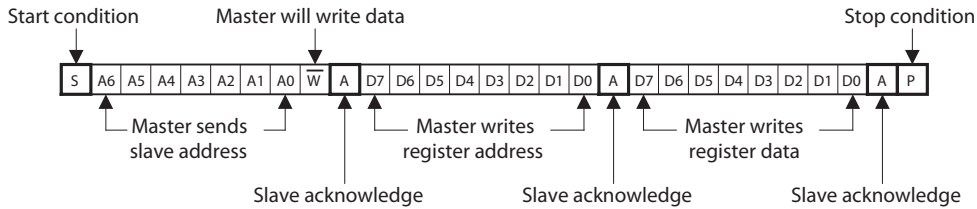

Figure 10. Register Byte Write Protocol

To read from a register, the master first generates a START condition. Then it sends the slave address for the device it wants to communicate with. The least significant bit (LSB) of the slave address must indicate that the master wants to write to the slave. The addressed device will then acknowledge the master.

The master writes the register address it wants to access and waits for the slave to acknowledge. The master then generates a repeated START condition and resends the slave address sent previously. The least significant bit (LSB) of the slave address must indicate that the master wants to read from the slave. The addressed device will then acknowledge the master.

The master reads the register data sent by the slave and sends a no acknowledge signal to stop reading. The master then generates a STOP condition to end the data transfer.

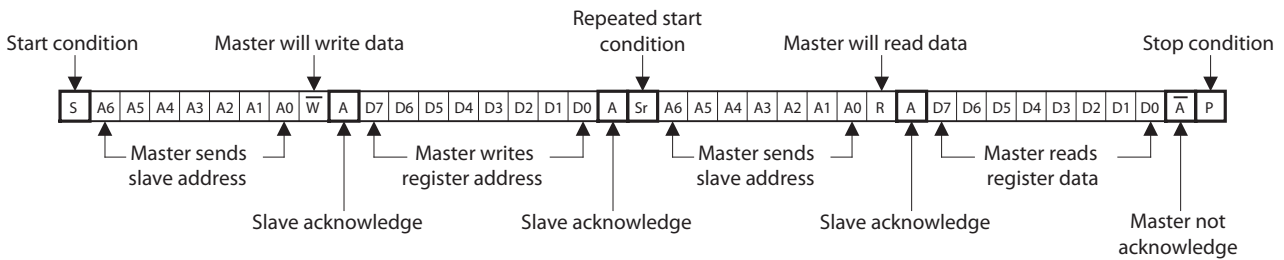

Figure 11. Register Byte Read Protocol

Application Diagram

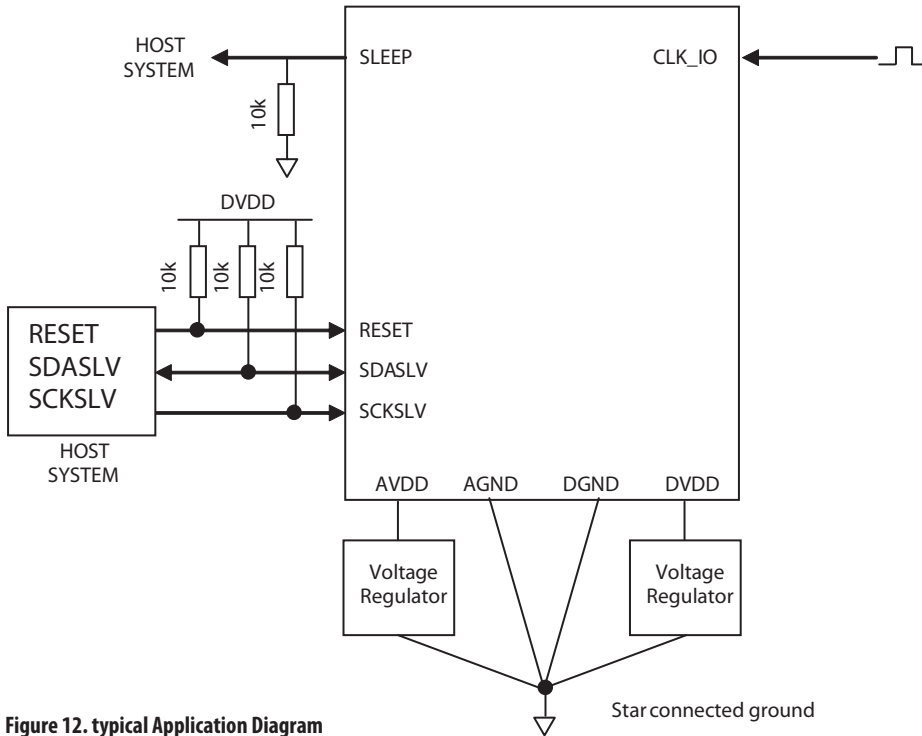
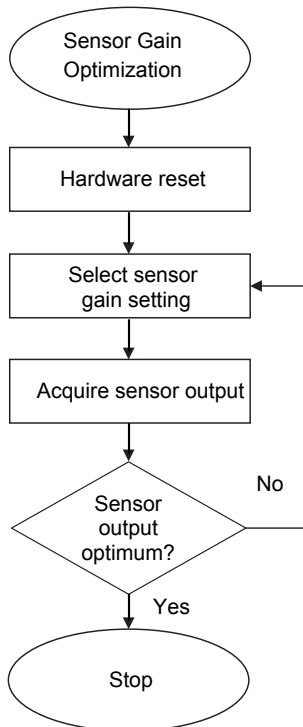

Figure 12. typical Application Diagram

High Level Description

The sensor needs to be configured before it can be used. The gain selection needs to be set for optimum performance depending on light levels. The flowcharts below describe the different procedures required.

Sensor gain optimization flowchart



Sensor operation flowchart

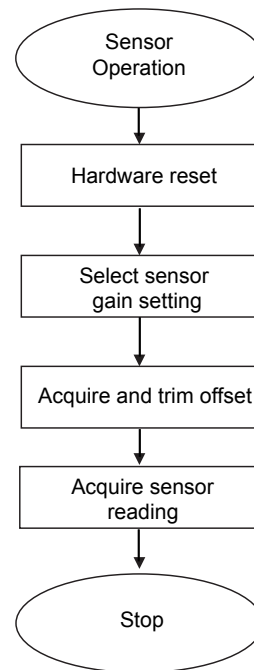

* Please refer to application note for more detailed information.

Detail Description

A hardware reset (by asserting XRST) should be performed before starting any operation.

Sensor Gain Settings

The sensor gain can be adjusted by varying the number of capacitors and integration time slot of the sensor manually through the following registers.

| Address (Hex) | Register | Description |
|---------------|-----------|--|
| 6 | CAP_RED | Number of red channel capacitors |
| 7 | CAP_GREEN | Number of green channel capacitors |
| 8 | CAP_BLUE | Number of blue channel capacitors |
| 9 | CAP_CLEAR | Number of clear channel capacitors |
| A | INT_RED | Number of red channel integration time slots |
| C | INT_GREEN | Number of green channel integration time slots |
| E | INT_BLUE | Number of blue channel integration time slots |
| 10 | INT_CLEAR | Number of clear channel integration time slots |

Sensor ADC Output Registers

To obtain sensor ADC value, '01' Hex must be written to CTRL register. Then, read the value from CTRL register. If value is 00H, can read sensor output from data register.

| Address (Hex) | Register | Description |
|---------------|---------------|------------------------------------|
| 00 | CTRL | Control register |
| 40 | DATA_RED_LO | Red channel ADC data – low byte |
| 41 | DATA_RED_HI | Red channel ADC data – high byte |
| 42 | DATA_GREEN_LO | Green channel ADC data – low byte |
| 43 | DATA_GREEN_HI | Green channel ADC data – high byte |
| 44 | DATA_BLUE_LO | Blue channel ADC data – low byte |
| 45 | DATA_BLUE_HI | Blue channel ADC data – high byte |
| 46 | DATA_CLEAR_LO | Clear channel ADC data – low byte |
| 47 | DATA_CLEAR_HI | Clear channel ADC data – high byte |

* Please refer to application note for more detailed information.

Setup Value for Number of Integration Time Slot

The following value can be written to each of the integration time registers to adjust the gain of the sensor. The default value after reset for these registers is 00H. These registers control the number of integration time selected for each channel. The integration time slot can be varied from 00H to FFFH. More integration time slot will give higher sensitivity.

Setup Value for Number of Capacitor

The following value can be written to each of the capacitor registers to adjust the gain of the sensor. The default value after reset for these registers is 0FH. These registers control the number of capacitors selected for each channel. The maximum selectable capacitor is 16 with the registers starting from 0 (i.e. 0 to 15). Less capacitor will give higher sensitivity.

| Value (Hex) | Number of Capacitor |
|-------------|---------------------|
| 00 | 1 |
| 01 | 2 |
| 02 | 3 |
| 03 | 4 |
| 04 | 5 |
| 05 | 6 |
| 06 | 7 |
| 07 | 8 |
| 08 | 9 |
| 09 | 10 |
| 0A | 11 |
| 0B | 12 |
| 0C | 13 |
| 0D | 14 |
| 0E | 15 |
| 0F | 16 |

* Please refer to application note for more detailed information.

Mechanical Drawing

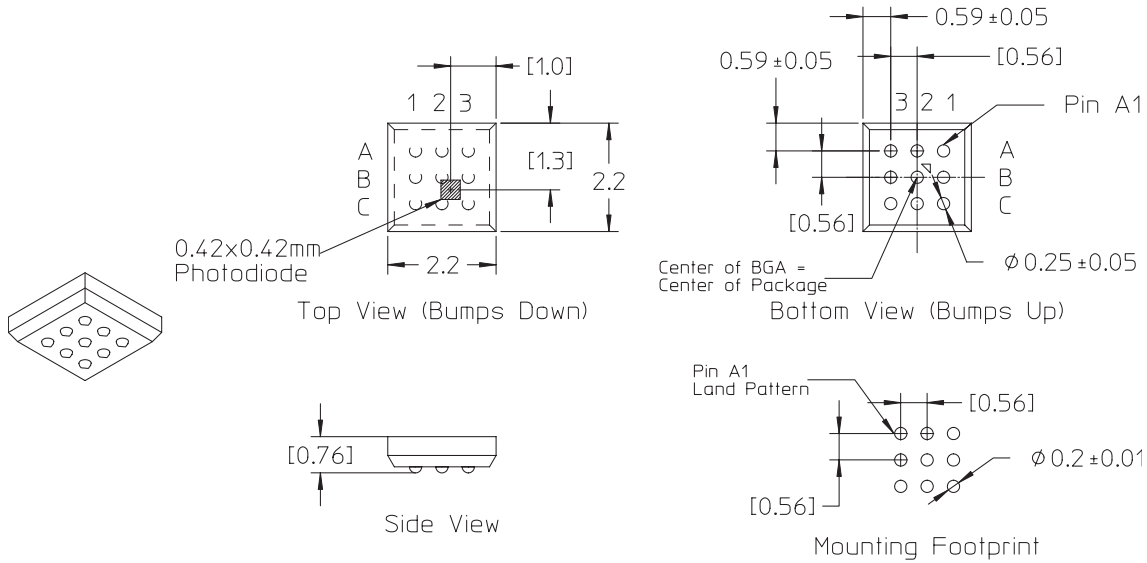

Note:

- Dimensions are in millimeters (mm)
- Standard tolerances (unless otherwise specified)
 - Linear tolerance = ± 0.1 mm
 - Angular tolerance = $\pm 1^\circ$

Pin Configuration

| | 1 | 2 | 3 |
|---|-------|--------|-------|
| A | DVDD | SCKSLV | AVDD |
| B | CLKIO | SDASLV | SLEEP |
| C | DGND | RESET | AGND |

Dimensions

| Description | Nominal (um) |
|--------------------------|--------------|
| Package Body Dimension X | 2200 |
| Package Body Dimension Y | 2200 |
| Package Height | 760 |
| Ball Diameter | 250 |
| Total Pin Count | 9 |

Pin Information

| Pin | Name | Type | Description |
|-----|--------|--------------|--|
| A1 | DVDD | Power | Digital power pin |
| A2 | SCKSLV | Input | Serial interface clock pin |
| A3 | AVDD | Power | Analog power pin |
| B1 | CLKIO | Input | External clock input |
| B2 | SDASLV | Input/Output | Bidirectional data pin. A pull-up resistor should be tied to SDASLV because it goes tri-state to output logic 1 |
| B3 | SLEEP | Input | When SLEEP = 1, the device goes into sleep mode. In sleep mode, all analog circuits are powered down and the clock signal is gated away from the core logic resulting in very low current consumption. |
| C1 | DGND | Ground | Tie to digital ground |
| C2 | RESET | Input | Global, asynchronous, active-low system reset. When asserted low, XRST resets all registers. Minimum reset pulse low is 1us and must be provided by external circuitry. |
| C3 | AGND | Power | Tie to analog ground |

Recommended Underfill Type and Characteristic

- Henkel FP4548
- Low moisture absorption
- Low CTE
- Underfill up to 70-85% of height

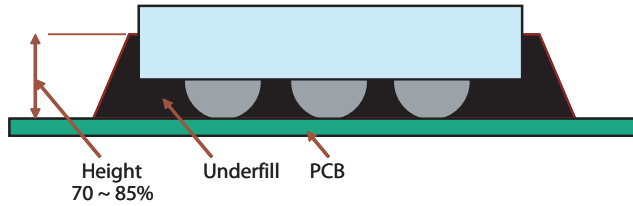

Recommended PCB land pad design

- NiAu flash over copper pad
- Pad Diameter (C)= 0.20 mm
- NSMD Diameter (D)= 0.25 ~ 0.30 mm

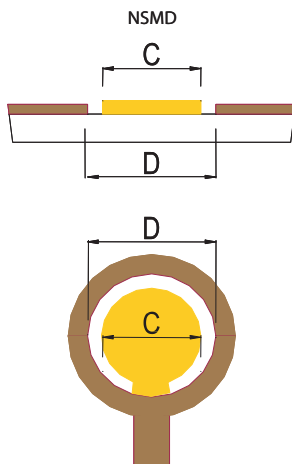

Recommended stencil design

- Stencil thickness 5 mils
- Stencil type Ni Electroforming
- Stencil Aperture Type Square
- Stencil Aperture 310 um
- Additional Feature Rounded square edge

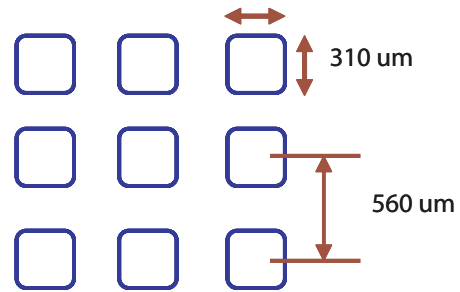

After soldering or mounting precaution

Please ensure that all soldered or reflowed CSP package that is mounted on the PCB is not exposed to compression or loading force directly perpendicular to the flat top surface.

Precaution:

Excessive loading force directly perpendicular to the flat top surface may cause pre-mature failure.

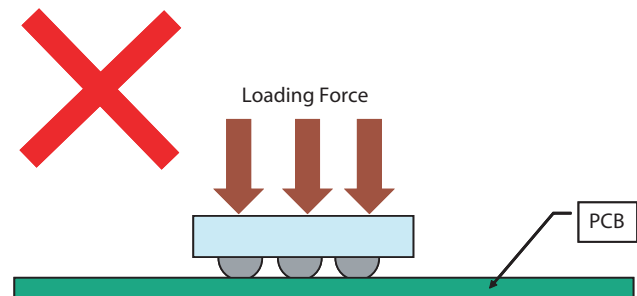

Recommended Reflow Profile

It is recommended that Henkel Pb-free solder paste LF310 be used for soldering ADJD-S311-CR999. Below is the recommended reflow profile.

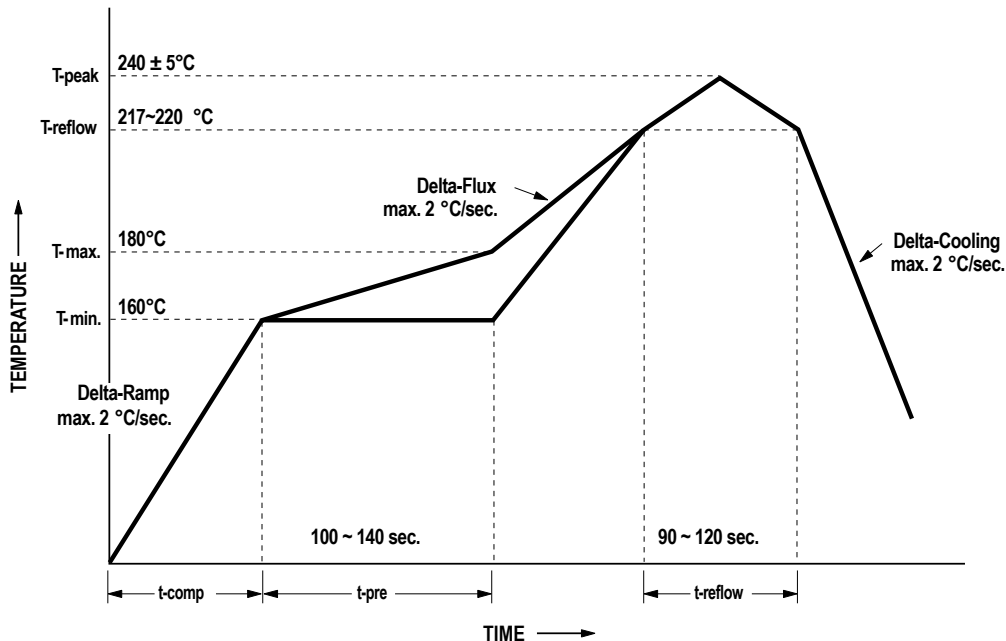

Recommendations for Handling and Storage of ADJD-S311-CR999

This product is qualified as Moisture Sensitive Level 3 per Jecdec J-STD-020. Precautions when handling this moisture sensitive product is important to ensure the reliability of the product. Do refer to Avago Application Note AN5305 Handling Of Moisture Sensitive Surface Mount Devices for details.

A. Storage before use

- Unopened moisture barrier bag (MBB) can be stored at 30°C and 90%RH or less for maximum 1 year
- It is not recommended to open the MBB prior to assembly (e.g. for IQC)
- It should also be sealed with a moisture absorbent material (Silica Gel) and an indicator card (cobalt chloride) to indicate the moisture within the bag

B. Control after opening the MBB

- The humidity indicator card (HIC) shall be read immediately upon opening of MBB
- The components must be kept at <30°C/60%RH at all time and all high temperature related process including soldering, curing or rework need to be completed within 168hrs

C. Control for unfinished reel

- For any unused components, they need to be stored in sealed MBB with desiccant or desiccator at <5%RH

D. Control of assembled boards

- If the PCB soldered with the components is to be subjected to other high temperature processes, the PCB need to be stored in sealed MBB with desiccant or desiccator at <5%RH to ensure no components have exceeded their floor life of 168hrs

E. Baking is required if:

- "10%" or "15%" HIC indicator turns pink
- The components are exposed to condition of >30°C/60%RH at any time.
- The components floor life exceeded 168hrs
- Recommended baking condition (in component form): 125°C for 24hrs

Package Tape and Reel Dimensions

Reel Dimensions

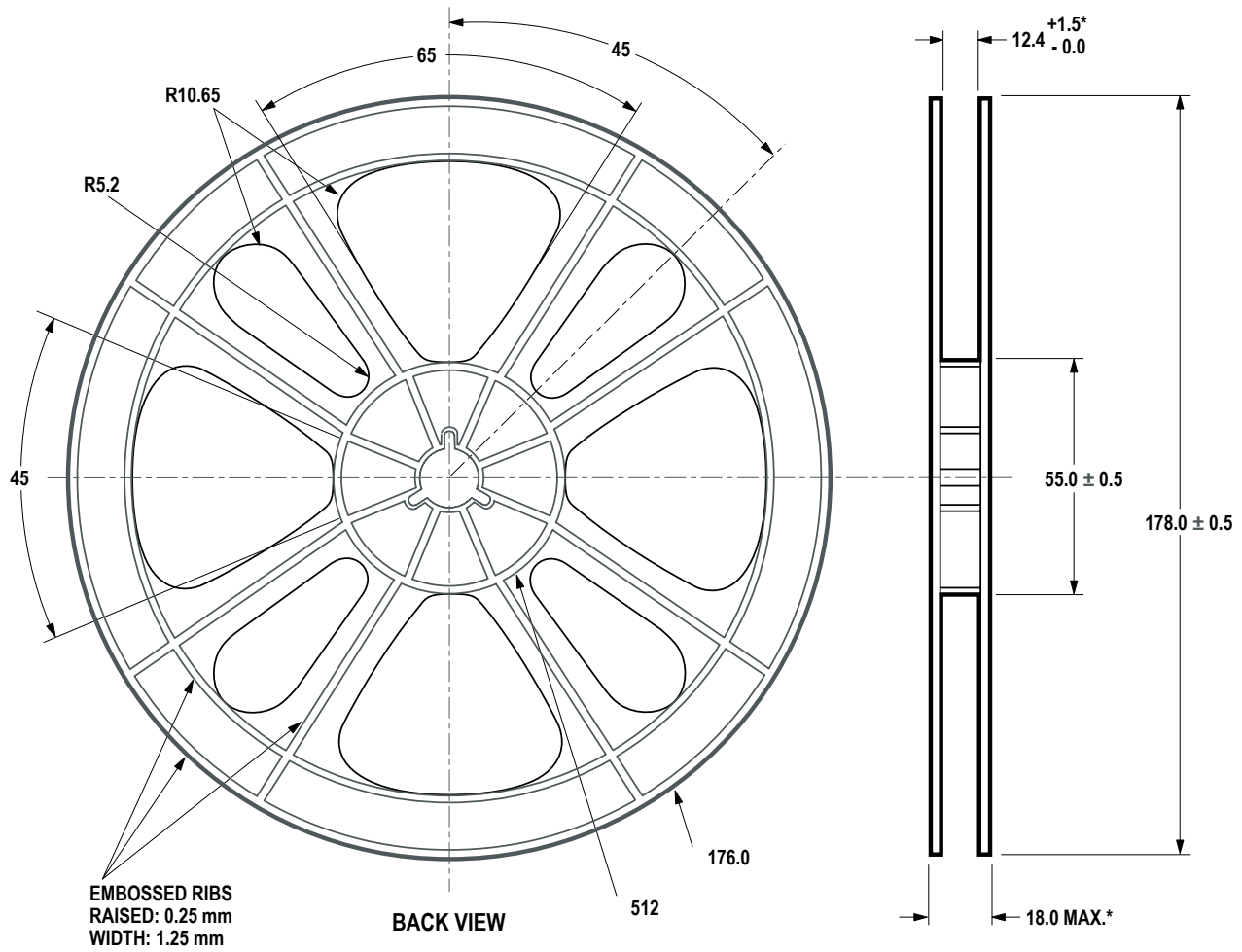

Notes:

1. *Measure at hub area.
2. All flange edges to be rounded.

Carrier Tape Dimensions

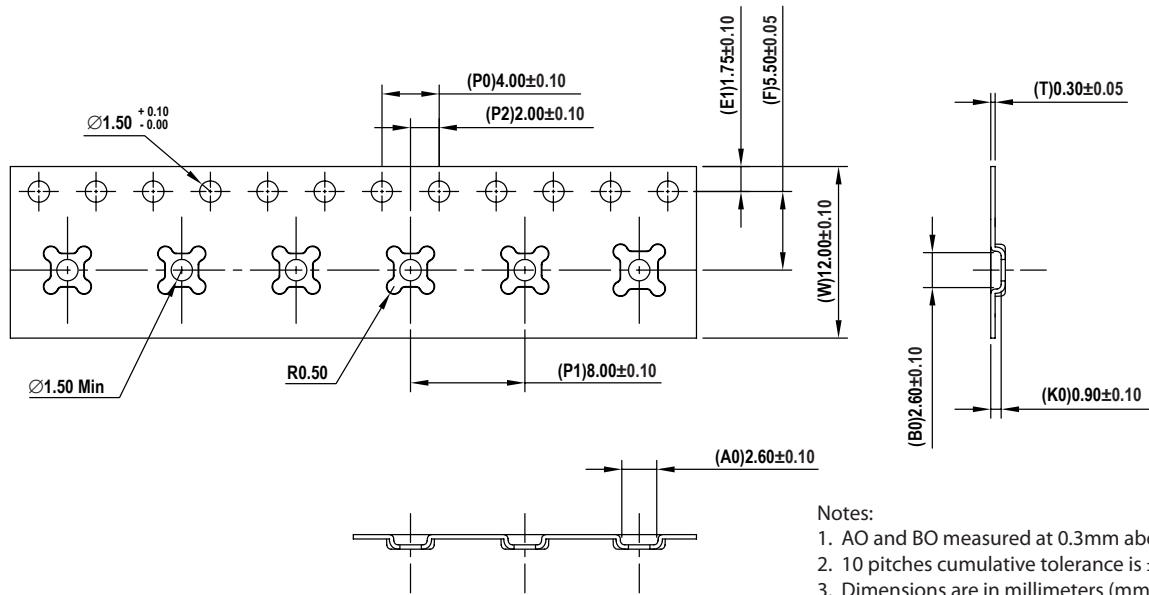

Appendix A: Sensor Register List

| | ADD (DEC) | ADD (HEX) | MNEMONIC | WIDTH | RESET (DEC) | TYPE | ACCESS | B7 | B6 | B5 | B4 | B3 | B2 | B1 | B0 | NOTES |
|-------------|-----------|---------------|---------------|-------|-------------|--------|-----------------|-----------------|-------------------|----|-----------------|-----------------|-------|----------------|-----------------|-------|
| FN | 0 | 0 | CTRL | 2 | 0 | BITS | R/W | N/A | | | | | | GOF5 | GSSR | |
| | 1 | 1 | CONFIG | 3 | 0 | BITS | R/W | N/A | | | | EXTCLK | SLEEP | TOFS | | |
| SENSOR | 6 | 6 | CAP_RED | 4 | 15 | NUMBER | R/W | N/A | | | | CAP_RED[3:0] | | | | |
| | 7 | 7 | CAP_GREEN | 4 | 15 | NUMBER | R/W | N/A | | | | CAP_GREEN[3:0] | | | | |
| | 8 | 8 | CAP_BLUE | 4 | 15 | NUMBER | R/W | N/A | | | | CAP_BLUE[3:0] | | | | |
| | 9 | 9 | CAP_CLEAR | 4 | 15 | NUMBER | R/W | N/A | | | | CAP_CLEAR[3:0] | | | | |
| | 10 | A | INT_RED_LO | 8 | 0 | NUMBER | R/W | INT_RED[7:0] | | | | | | | | |
| | 11 | B | INT_RED_HI | 8 | 0 | NUMBER | R/W | INT_RED[11:8] | | | | | | | | |
| | 12 | C | INT_GREEN_LO | 8 | 0 | NUMBER | R/W | INT_GREEN[7:0] | | | | | | | | |
| | 13 | D | INT_GREEN_HI | 8 | 0 | NUMBER | R/W | INT_GREEN[11:8] | | | | | | | | |
| | 14 | E | INT_BLUE_LO | 8 | 0 | NUMBER | R/W | INT_BLUE[7:0] | | | | | | | | |
| | 15 | F | INT_BLUE_HI | 8 | 0 | NUMBER | R/W | INT_BLUE[11:8] | | | | | | | | |
| 16 | 10 | INT_CLEAR_LO | 8 | 0 | NUMBER | R/W | INT_CLEAR[7:0] | | | | | | | | | |
| 17 | 11 | INT_CLEAR_HI | 8 | 0 | NUMBER | R/W | INT_CLEAR[11:8] | | | | | | | | | |
| SAMPLE DATA | 64 | 40 | DATA_RED_LO | 8 | 0 | NUMBER | R | DATA_RED[7:0] | | | | | | 11/10-bit data | | |
| | 65 | 41 | DATA_RED_HI | 3 | 0 | NUMBER | R | N/A | | | | DATA_RED[9:8] | | | | |
| | 66 | 42 | DATA_GREEN_LO | 8 | 0 | NUMBER | R | DATA_GREEN[7:0] | | | | | | | | |
| | 67 | 43 | DATA_GREEN_HI | 3 | 0 | NUMBER | R | N/A | | | | DATA_GREEN[9:8] | | | | |
| | 68 | 44 | DATA_BLUE_LO | 8 | 0 | NUMBER | R | DATA_BLUE[7:0] | | | | | | | | |
| | 69 | 45 | DATA_BLUE_HI | 3 | 0 | NUMBER | R | N/A | | | | DATA_BLUE[9:8] | | | | |
| | 70 | 46 | DATA_CLEAR_LO | 8 | 0 | NUMBER | R | DATA_CLEAR[7:0] | | | | | | | | |
| 71 | 47 | DATA_CLEAR_HI | 3 | 0 | NUMBER | R | N/A | | | | DATA_CLEAR[9:8] | | | | | |
| OFFSET DATA | 72 | 48 | OFFSET_RED | 8 | 0 | NUMBER | R | SIGN_RED | OFFSET_RED[6:0] | | | | | | sign = 1 is -ve | |
| | 73 | 49 | OFFSET_GREEN | 8 | 0 | NUMBER | R | SIGN_GREEN | OFFSET_GREEN[6:0] | | | | | | | |
| | 74 | 4A | OFFSET_BLUE | 8 | 0 | NUMBER | R | SIGN_BLUE | OFFSET_BLUE[6:0] | | | | | | | |
| | 75 | 4B | OFFSET_CLEAR | 8 | 0 | NUMBER | R | SIGN_CLEAR | OFFSET_CLEAR[6:0] | | | | | | | |

Appendix A: Sensor Register List

1) CTRL: Control Register

| B7 | B6 | B5 | B4 | B3 | B2 | B1 | B0 |
|-----|----|----|----|----|----|------|------|
| N/A | | | | | | GOFS | GSSR |

| | |
|------|--|
| N/A | Not available. |
| GSSR | Get sensor reading. Active high and automatically cleared. Result is stored in registers 64-71 (DEC) |
| GOFS | Get offset reading. Active high and automatically cleared. Result is stored in registers 72-75 (DEC) |

2) CONFIG: Configuration Register

| B7 | B6 | B5 | B4 | B3 | B2 | B1 | B0 |
|-----|----|----|----|----|--------|-------|------|
| N/A | | | | | EXTCLK | SLEEP | TOFS |

| | |
|--------|---|
| N/A | Not available. |
| EXTCLK | External clock mode. Active high. |
| SLEEP | Sleep mode. Active high and external clock mode only. Automatically cleared if otherwise. |
| TOFS | Trim offset mode. Active high. |

3) CAP_RED: Capacitor Settings Register for Red Channel

| B7 | B6 | B5 | B4 | B3 | B2 | B1 | B0 |
|-----|----|----|----|--------------|----|----|----|
| N/A | | | | CAP_RED[3:0] | | | |

| | |
|---------|-----------------------------------|
| N/A | Not available. |
| CAP_RED | Number of red channel capacitors. |

4) CAP_GREEN: Capacitor Settings Register for Green Channel

| B7 | B6 | B5 | B4 | B3 | B2 | B1 | B0 |
|-----|----|----|----|----------------|----|----|----|
| N/A | | | | CAP_GREEN[3:0] | | | |

| | |
|-----------|-------------------------------------|
| N/A | Not available. |
| CAP_GREEN | Number of green channel capacitors. |

5) CAP_BLUE: Capacitor Settings Register for Blue Channel

| B7 | B6 | B5 | B4 | B3 | B2 | B1 | B0 |
|-----|----|----|----|---------------|----|----|----|
| N/A | | | | CAP_BLUE[3:0] | | | |

| | |
|----------|------------------------------------|
| N/A | Not available. |
| CAP_BLUE | Number of blue channel capacitors. |

6) CAP_CLEAR: Capacitor Settings Register for Clear Channel

| B7 | B6 | B5 | B4 | B3 | B2 | B1 | B0 |
|-----|----|----|----|----------------|----|----|----|
| N/A | | | | CAP_CLEAR[3:0] | | | |

| | |
|-----------|-------------------------------------|
| N/A | Not available. |
| CAP_CLEAR | Number of clear channel capacitors. |

7) INT_RED: Integration Time Slot Setting Register for Red Channel

| | | | | | | | |
|--------------|---|----|----|---------------|----|----|----|
| B7 | B6 | B5 | B4 | B3 | B2 | B1 | B0 |
| INT_RED[7:0] | | | | | | | |
| B7 | B6 | B5 | B4 | B3 | B2 | B1 | B0 |
| N/A | | | | INT_RED[11:8] | | | |
| INT_RED | Number of red channel integration time slots. | | | | | | |

8) INT_GREEN: Integration Time Slot Setting Register for Green Channel

| | | | | | | | |
|----------------|---|----|----|-----------------|----|----|----|
| B7 | B6 | B5 | B4 | B3 | B2 | B1 | B0 |
| INT_GREEN[7:0] | | | | | | | |
| B7 | B6 | B5 | B4 | B3 | B2 | B1 | B0 |
| N/A | | | | INT_GREEN[11:8] | | | |
| INT_GREEN | Number of green channel integration time slots. | | | | | | |

9) INT_BLUE: Integration Time Slot Setting Register for Blue Channel

| | | | | | | | |
|---------------|--|----|----|----------------|----|----|----|
| B7 | B6 | B5 | B4 | B3 | B2 | B1 | B0 |
| INT_BLUE[7:0] | | | | | | | |
| B7 | B6 | B5 | B4 | B3 | B2 | B1 | B0 |
| N/A | | | | INT_BLUE[11:8] | | | |
| INT_BLUE | Number of blue channel integration time slots. | | | | | | |

10) INT_CLEAR: Integration Time Slot Setting Register for Clear Channel

| | | | | | | | |
|----------------|---|----|----|-----------------|----|----|----|
| B7 | B6 | B5 | B4 | B3 | B2 | B1 | B0 |
| INT_CLEAR[7:0] | | | | | | | |
| B7 | B6 | B5 | B4 | B3 | B2 | B1 | B0 |
| N/A | | | | INT_CLEAR[11:8] | | | |
| INT_CLEAR | Number of clear channel integration time slots. | | | | | | |

11) DATA_RED_LO: Low Byte Register of Red Channel Sensor ADC Reading

| | | | | | | | |
|---------------|-----------------------|----|----|----|----|----|----|
| B7 | B6 | B5 | B4 | B3 | B2 | B1 | B0 |
| DATA_RED[7:0] | | | | | | | |
| DATA_RED | Red channel ADC data. | | | | | | |

12) DATA_RED_HI: High Byte Register of Red Channel Sensor ADC Reading

| B7 | B6 | B5 | B4 | B3 | B2 | B1 | B0 |
|-----|----|----|----|----|----|---------------|----|
| N/A | | | | | | DATA_RED[9:8] | |

| | |
|----------|-----------------------|
| N/A | Not available. |
| DATA_RED | Red channel ADC data. |

13) DATA_GREEN_LO: Low Byte Register of Green Channel Sensor ADC Reading

| B7 | B6 | B5 | B4 | B3 | B2 | B1 | B0 |
|-----------------|----|----|----|----|----|----|----|
| DATA_GREEN[7:0] | | | | | | | |

| | |
|------------|-------------------------|
| DATA_GREEN | Green channel ADC data. |
|------------|-------------------------|

14) DATA_GREEN_HI: High Byte Register of Green Channel Sensor ADC Reading

| B7 | B6 | B5 | B4 | B3 | B2 | B1 | B0 |
|-----|----|----|----|----|----|-----------------|----|
| N/A | | | | | | DATA_GREEN[9:8] | |

| | |
|------------|-------------------------|
| N/A | Not available. |
| DATA_GREEN | Green channel ADC data. |

15) DATA_BLUE_LO: Low Byte Register of Blue Channel Sensor ADC Reading

| B7 | B6 | B5 | B4 | B3 | B2 | B1 | B0 |
|----------------|----|----|----|----|----|----|----|
| DATA_BLUE[7:0] | | | | | | | |

| | |
|-----------|------------------------|
| DATA_BLUE | Blue channel ADC data. |
|-----------|------------------------|

16) DATA_BLUE_HI: High Byte Register of Blue Channel Sensor ADC Reading

| B7 | B6 | B5 | B4 | B3 | B2 | B1 | B0 |
|-----|----|----|----|----|----|----------------|----|
| N/A | | | | | | DATA_BLUE[9:8] | |

| | |
|-----------|------------------------|
| N/A | Not available. |
| DATA_BLUE | Blue channel ADC data. |

17) DATA_CLEAR_LO: Low Byte Register of Clear Channel Sensor ADC Reading

| B7 | B6 | B5 | B4 | B3 | B2 | B1 | B0 |
|-----------------|----|----|----|----|----|----|----|
| DATA_CLEAR[7:0] | | | | | | | |

| | |
|------------|-------------------------|
| DATA_CLEAR | Clear channel ADC data. |
|------------|-------------------------|

18) DATA_CLEAR_HI: High Byte Register of Clear Channel Sensor ADC Reading

| B7 | B6 | B5 | B4 | B3 | B2 | B1 | B0 |
|-----|----|----|----|----|----|-----------------|----|
| N/A | | | | | | DATA_CLEAR[9:8] | |

| | |
|------------|-------------------------|
| N/A | Not available. |
| DATA_CLEAR | Clear channel ADC data. |

19) OFFSET_RED: Offset Data Register for Red Channel

| B7 | B6 | B5 | B4 | B3 | B2 | B1 | B0 |
|----------|-----------------|----|----|----|----|----|----|
| SIGN_RED | OFFSET_RED[6:0] | | | | | | |

| | |
|------------|---------------------------------------|
| SIGN_RED | Sign bit. 0 = POSITIVE, 1 = NEGATIVE. |
| OFFSET_RED | Red channel ADC offset data. |

20) OFFSET_GREEN: Offset Data Register for Green Channel

| B7 | B6 | B5 | B4 | B3 | B2 | B1 | B0 |
|------------|-------------------|----|----|----|----|----|----|
| SIGN_GREEN | OFFSET_GREEN[6:0] | | | | | | |

| | |
|--------------|---------------------------------------|
| SIGN_GREEN | Sign bit. 0 = POSITIVE, 1 = NEGATIVE. |
| OFFSET_GREEN | Green channel ADC offset data. |

21) OFFSET_BLUE: Offset Data Register for Blue Channel

| B7 | B6 | B5 | B4 | B3 | B2 | B1 | B0 |
|-----------|------------------|----|----|----|----|----|----|
| SIGN_BLUE | OFFSET_BLUE[6:0] | | | | | | |

| | |
|-------------|---------------------------------------|
| SIGN_BLUE | Sign bit. 0 = POSITIVE, 1 = NEGATIVE. |
| OFFSET_BLUE | Blue channel ADC offset data. |

22) OFFSET_CLEAR: Offset Data Register for Clear Channel

| B7 | B6 | B5 | B4 | B3 | B2 | B1 | B0 |
|------------|-------------------|----|----|----|----|----|----|
| SIGN_CLEAR | OFFSET_CLEAR[6:0] | | | | | | |

| | |
|--------------|---------------------------------------|
| SIGN_CLEAR | Sign bit. 0 = POSITIVE, 1 = NEGATIVE. |
| OFFSET_CLEAR | Clear channel ADC offset data. |

For product information and a complete list of distributors, please go to our web site: www.avagotech.com

Avago, Avago Technologies, and the A logo are trademarks of Avago Technologies, Limited in the United States and other countries. Data subject to change. Copyright © 2007 Avago Technologies Limited. All rights reserved. AV02-0191EN - July 30, 2007

