

Chipsmall Limited consists of a professional team with an average of over 10 year of expertise in the distribution of electronic components. Based in Hongkong, we have already established firm and mutual-benefit business relationships with customers from,Europe,America and south Asia,supplying obsolete and hard-to-find components to meet their specific needs.

With the principle of “Quality Parts,Customers Priority,Honest Operation,and Considerate Service”,our business mainly focus on the distribution of electronic components. Line cards we deal with include Microchip,ALPS,ROHM,Xilinx,Pulse,ON,Everlight and Freescale. Main products comprise IC,Modules,Potentiometer,IC Socket,Relay,Connector.Our parts cover such applications as commercial,industrial, and automotives areas.

We are looking forward to setting up business relationship with you and hope to provide you with the best service and solution. Let us make a better world for our industry!



Contact us

Tel: +86-755-8981 8866 Fax: +86-755-8427 6832

Email & Skype: info@chipsmall.com Web: www.chipsmall.com

Address: A1208, Overseas Decoration Building, #122 Zhenhua RD., Futian, Shenzhen, China



MICROCHIP

**MCP16251 and MCP1640B
Synchronous Boost Converters
Evaluation Board
User's Guide**

Note the following details of the code protection feature on Microchip devices:

- Microchip products meet the specification contained in their particular Microchip Data Sheet.
- Microchip believes that its family of products is one of the most secure families of its kind on the market today, when used in the intended manner and under normal conditions.
- There are dishonest and possibly illegal methods used to breach the code protection feature. All of these methods, to our knowledge, require using the Microchip products in a manner outside the operating specifications contained in Microchip's Data Sheets. Most likely, the person doing so is engaged in theft of intellectual property.
- Microchip is willing to work with the customer who is concerned about the integrity of their code.
- Neither Microchip nor any other semiconductor manufacturer can guarantee the security of their code. Code protection does not mean that we are guaranteeing the product as "unbreakable."

Code protection is constantly evolving. We at Microchip are committed to continuously improving the code protection features of our products. Attempts to break Microchip's code protection feature may be a violation of the Digital Millennium Copyright Act. If such acts allow unauthorized access to your software or other copyrighted work, you may have a right to sue for relief under that Act.

Information contained in this publication regarding device applications and the like is provided only for your convenience and may be superseded by updates. It is your responsibility to ensure that your application meets with your specifications. MICROCHIP MAKES NO REPRESENTATIONS OR WARRANTIES OF ANY KIND WHETHER EXPRESS OR IMPLIED, WRITTEN OR ORAL, STATUTORY OR OTHERWISE, RELATED TO THE INFORMATION, INCLUDING BUT NOT LIMITED TO ITS CONDITION, QUALITY, PERFORMANCE, MERCHANTABILITY OR FITNESS FOR PURPOSE. Microchip disclaims all liability arising from this information and its use. Use of Microchip devices in life support and/or safety applications is entirely at the buyer's risk, and the buyer agrees to defend, indemnify and hold harmless Microchip from any and all damages, claims, suits, or expenses resulting from such use. No licenses are conveyed, implicitly or otherwise, under any Microchip intellectual property rights.

Trademarks

The Microchip name and logo, the Microchip logo, dsPIC, FlashFlex, KEELOQ, KEELOQ logo, MPLAB, PIC, PICmicro, PICSTART, PIC³² logo, rPIC, SST, SST Logo, SuperFlash and UNI/O are registered trademarks of Microchip Technology Incorporated in the U.S.A. and other countries.

FilterLab, Hampshire, HI-TECH C, Linear Active Thermistor, MTP, SEEVAL and The Embedded Control Solutions Company are registered trademarks of Microchip Technology Incorporated in the U.S.A.

Silicon Storage Technology is a registered trademark of Microchip Technology Inc. in other countries.

Analog-for-the-Digital Age, Application Maestro, BodyCom, chipKIT, chipKIT logo, CodeGuard, dsPICDEM, dsPICDEM.net, dsPICworks, dsSPEAK, ECAN, ECONOMONITOR, FanSense, HI-TIDE, In-Circuit Serial Programming, ICSP, Mindi, MiWi, MPASM, MPF, MPLAB Certified logo, MPLIB, MPLINK, mTouch, Omniscent Code Generation, PICC, PICC-18, PICDEM, PICDEM.net, PICkit, PICtail, REAL ICE, rLAB, Select Mode, SQI, Serial Quad I/O, Total Endurance, TSHARC, UniWinDriver, WiperLock, ZENA and Z-Scale are trademarks of Microchip Technology Incorporated in the U.S.A. and other countries.

SQTP is a service mark of Microchip Technology Incorporated in the U.S.A.

GestIC and ULPP are registered trademarks of Microchip Technology Germany II GmbH & Co. KG, a subsidiary of Microchip Technology Inc., in other countries.

All other trademarks mentioned herein are property of their respective companies.

© 2013, Microchip Technology Incorporated, Printed in the U.S.A., All Rights Reserved.

 Printed on recycled paper.

ISBN: 978-1-62077-320-8

**QUALITY MANAGEMENT SYSTEM
CERTIFIED BY DNV
= ISO/TS 16949 =**

Microchip received ISO/TS-16949:2009 certification for its worldwide headquarters, design and wafer fabrication facilities in Chandler and Tempe, Arizona; Gresham, Oregon and design centers in California and India. The Company's quality system processes and procedures are for its PIC[®] MCUs and dsPIC[®] DSCs, KEELOQ[®] code hopping devices, Serial EEPROMs, microperipherals, nonvolatile memory and analog products. In addition, Microchip's quality system for the design and manufacture of development systems is ISO 9001:2000 certified.

Object of Declaration: MCP16251 and MCP1640B Synchronous Boost Converters Evaluation Board

EU Declaration of Conformity

This declaration of conformity is issued by the manufacturer.

The development/evaluation tool is designed to be used for research and development in a laboratory environment. This development/evaluation tool is not a Finished Appliance, nor is it intended for incorporation into Finished Appliances that are made commercially available as single functional units to end users under EU EMC Directive 2004/108/EC and as supported by the European Commission's Guide for the EMC Directive 2004/108/EC (8th February 2010).

This development/evaluation tool complies with EU RoHS2 Directive 2011/65/EU.

For information regarding the exclusive, limited warranties applicable to Microchip products, please see Microchip's standard terms and conditions of sale, which are printed on our sales documentation and available at www.microchip.com.

Signed for and on behalf of Microchip Technology Inc. at Chandler, Arizona, USA

Derek Carlson
VP Development Tools

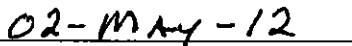
Date

NOTES:



MCP16251 AND MCP1640B SYNCHRONOUS BOOST CONVERTERS EVALUATION BOARD USER'S GUIDE

Table of Contents

Preface	7
Introduction.....	7
Document Layout	7
Conventions Used in this Guide	8
Recommended Reading.....	9
The Microchip Web Site	9
Customer Support	9
Document Revision History	10
Chapter 1. Product Overview	
1.1 Introduction	11
1.2 What is the MCP16251 and MCP1640B Synchronous Boost Converters Evaluation Board?	12
1.3 What the MCP16251 and MCP1640B Synchronous Boost Converters Evaluation Board Contains	12
Chapter 2. Installation and Operation	
2.1 Introduction	13
2.2 Board Features	14
2.3 Getting Started	14
2.3.1 Power Input and Output Connection	14
Appendix A. Schematic and Layouts	
A.1 Introduction	17
A.2 Board – Schematic	18
A.3 Board – Top Silk	19
A.4 Board – Top Copper and Silk	19
A.5 Board – Top Copper	20
A.6 Board – Bottom Copper	20
Appendix B. Bill of Materials (BOM)	
Worldwide Sales and Service	22

NOTES:



MCP16251 AND MCP1640B SYNCHRONOUS BOOST CONVERTERS EVALUATION BOARD USER'S GUIDE

Preface

NOTICE TO CUSTOMERS

All documentation becomes dated, and this manual is no exception. Microchip tools and documentation are constantly evolving to meet customer needs, so some actual dialogs and/or tool descriptions may differ from those in this document. Please refer to our web site (www.microchip.com) to obtain the latest documentation available.

Documents are identified with a “DS” number. This number is located on the bottom of each page, in front of the page number. The numbering convention for the DS number is “DSXXXXA”, where “XXXX” is the document number and “A” is the revision level of the document.

For the most up-to-date information on development tools, see the MPLAB® IDE online help. Select the Help menu, and then Topics to open a list of available online help files.

INTRODUCTION

This chapter contains general information that will be useful to know before using the MCP16251 and MCP1640B Synchronous Boost Converters Evaluation Board. Items discussed in this chapter include:

- Document Layout
- Conventions Used in this Guide
- Recommended Reading
- The Microchip Web Site
- Customer Support
- Document Revision History

DOCUMENT LAYOUT

This document describes how to use the MCP16251 and MCP1640B Synchronous Boost Converters Evaluation Board as a development tool. The manual layout is as follows:

- **Chapter 1. “Product Overview”** – Important information about the MCP16251 and MCP1640B Synchronous Boost Converters Evaluation Board.
- **Chapter 2. “Installation and Operation”** – Includes instructions on how to get started with this user’s guide and a description of the board.
- **Appendix A. “Schematic and Layouts”** – Shows the schematic and layout diagrams for the MCP16251 and MCP1640B Synchronous Boost Converters Evaluation Board.
- **Appendix B. “Bill of Materials (BOM)”** – Lists the parts used to build the MCP16251 and MCP1640B Synchronous Boost Converters Evaluation Board.

CONVENTIONS USED IN THIS GUIDE

This manual uses the following documentation conventions:

DOCUMENTATION CONVENTIONS

Description	Represents	Examples
Arial font:		
Italic characters	Referenced books	<i>MPLAB[®] IDE User's Guide</i>
	Emphasized text	...is the <i>only</i> compiler...
Initial caps	A window	the Output window
	A dialog	the Settings dialog
	A menu selection	select Enable Programmer
Quotes	A field name in a window or dialog	"Save project before build"
Underlined, italic text with right angle bracket	A menu path	<u><i>File>Save</i></u>
Bold characters	A dialog button	Click OK
	A tab	Click the Power tab
N'Rnnnn	A number in verilog format, where N is the total number of digits, R is the radix and n is a digit.	4'b0010, 2'hF1
Text in angle brackets < >	A key on the keyboard	Press <Enter>, <F1>
Courier New font:		
Plain Courier New	Sample source code	#define START
	Filenames	autoexec.bat
	File paths	c:\mcc18\h
	Keywords	_asm, _endasm, static
	Command-line options	-Opa+, -Opa-
	Bit values	0, 1
	Constants	0xFF, 'A'
Italic Courier New	A variable argument	<i>file.o</i> , where <i>file</i> can be any valid filename
Square brackets []	Optional arguments	mcc18 [options] <i>file</i> [options]
Curly brackets and pipe character: { }	Choice of mutually exclusive arguments; an OR selection	errorlevel {0 1}
Ellipses...	Replaces repeated text	var_name [, var_name...]
	Represents code supplied by user	void main (void) { ... }

RECOMMENDED READING

This user's guide describes how to use the MCP16251 and MCP1640B Synchronous Boost Converters Evaluation Board. Other useful documents are listed below. The following Microchip documents are available and recommended as supplemental reference resources.

- **MCP16251/2 Data Sheet – Low Quiescent Current, PFM/PWM Synchronous Boost Regulator with True Output Disconnect or Input/Output Bypass Option (DS25173)**

This data sheet provides detailed information regarding the MCP16251/2 device.

- **MCP1640/B/C/D Data Sheet – “0.65V Start-up Synchronous Boost Regulator with True Output Disconnect or Input/Output Bypass Option” (DS22234)**

This data sheet provides detailed information regarding the MCP1640B device.

- **MCP1623/24 Data Sheet – “Low-Voltage Input Boost Regulator for PIC[®] Microcontrollers” (DS41420)**

This data sheet provides detailed information regarding the MCP1623/4 device.

- **AN1311 – “Single Cell Input Boost Converter Design” (DS01311)**

This application note details how to use the MCP1640 device in specific applications.

THE MICROCHIP WEB SITE

Microchip provides online support via our web site at www.microchip.com. This web site is used as a means to make files and information easily available to customers. Accessible by using your favorite Internet browser, the web site contains the following information:

- **Product Support** – Data sheets and errata, application notes and sample programs, design resources, user's guides and hardware support documents, latest software releases and archived software
- **General Technical Support** – Frequently Asked Questions (FAQs), technical support requests, online discussion groups, Microchip consultant program member listing
- **Business of Microchip** – Product selector and ordering guides, latest Microchip press releases, listing of seminars and events, listings of Microchip sales offices, distributors and factory representatives

CUSTOMER SUPPORT

Users of Microchip products can receive assistance through several channels:

- Distributor or Representative
- Local Sales Office
- Field Application Engineer (FAE)
- Technical Support

Customers should contact their distributor, representative or field application engineer (FAE) for support. Local sales offices are also available to help customers. A listing of sales offices and locations is included in the back of this document.

Technical support is available through the web site at:

<http://www.microchip.com/support>.

DOCUMENT REVISION HISTORY

Revision B (July 2013)

- Updated [Appendix B. "Bill of Materials \(BOM\)"](#).

Revision A (April 2013)

- Initial Release of this Document.

Chapter 1. Product Overview

1.1 INTRODUCTION

The MCP16251 and MCP1640B devices are compact, high-efficiency, fixed frequency, step-up DC-DC converters. These products provide an easy-to-use power supply solution, with a minimum number of external components for applications powered by one-cell, two-cell, or three-cell alkaline, NiCd, NiMH, one-cell Li-Ion or Li-Polymer batteries.

The MCP16251 automatically selects the best operating mode for efficiency, pulse-width modulation (PWM) or pulse frequency (PFM). The device has a very low quiescent current 4 μ A (not switching, measured at output), a wide input voltage range (0.35 to 5.5V) and a low start-up voltage (0.82V) at 1 mA load current.

The MCP1640B is a PWM-only controller, with a typical of 19 μ A quiescent current (not switching, measured at output), a wide input voltage range (0.35V to 5.5V) and a start-up voltage of 0.65V at 1 mA load current.

The major differences between the two device families (MCP16251/2 and MCP1640/B/C/D) are the very low quiescent current for the MCP16251/2, and the voltage reference (1.21V for the MCP1640/B/C/D, 1.23V for the MCP16251/2, respectively).

The available package types for these devices are: SOT-23-6 and 2x3 mm (T)DFN-8.

The scope of this evaluation board is to demonstrate the low quiescent current for the PWM/PFM MCP16251 device, and the low-noise output for the MCP1640B PWM-only option.

This chapter provides an overview of the MCP16251 and MCP1640B Synchronous Boost Converters Evaluation Board, and covers the following topics:

- What is the MCP16251 and MCP1640B Synchronous Boost Converters Evaluation Board?
- What the MCP16251 and MCP1640B Synchronous Boost Converters Evaluation Board Contains

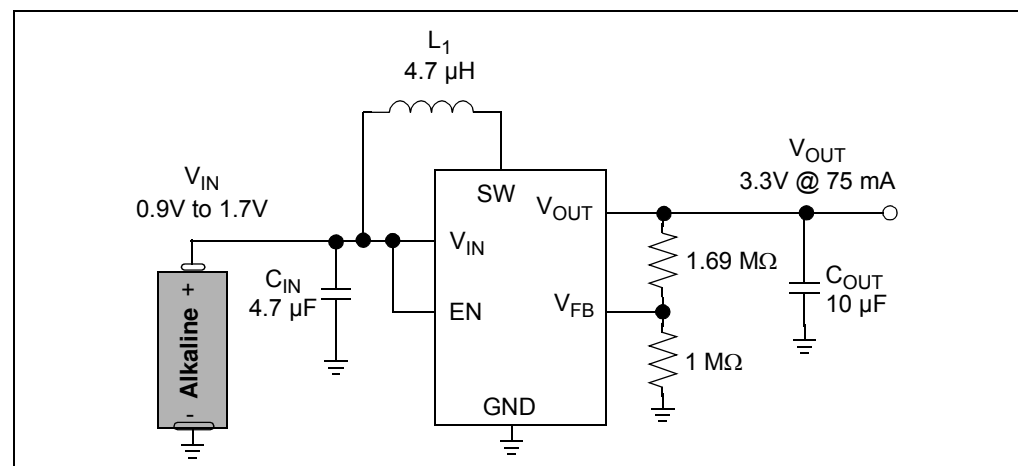

FIGURE 1-1: Typical MCP16251 Boost Converter Single-Cell Battery Input.

1.2 WHAT IS THE MCP16251 AND MCP1640B SYNCHRONOUS BOOST CONVERTERS EVALUATION BOARD?

The MCP16251 and MCP1640B Synchronous Boost Converters Evaluation Board is used to evaluate and demonstrate Microchip Technology's MCP16251 and MCP1640B products. This board demonstrates the MCP16251/MCP1640B in two boost-converter applications with multiple output voltages. It can be used to evaluate both package options (SOT-23-6 and 2x3 mm 8-(T)DFN). The MCP16251 and MCP1640B Synchronous Boost Converters Evaluation Board was developed to help engineers reduce the product design cycle time.

Three common output voltages can be selected: 2.0V, 3.3V and 5.0V. The output voltage can be changed with a mini-dip switch that changes the external resistor divider.

A switch connected to the EN pin is used to enable and disable the converters. When enabled, the MCP16251/MCP1640B will regulate the output voltage; when disabled, the MCP16251/MCP1640B disconnects the path from input to output for "true-disconnect".

1.3 WHAT THE MCP16251 AND MCP1640B SYNCHRONOUS BOOST CONVERTERS EVALUATION BOARD CONTAINS

This MCP16251 and MCP1640B Synchronous Boost Converters Evaluation Board kit includes:

- MCP16251 and MCP1640B Synchronous Boost Converters Evaluation Board (ADM00458)
- Important information sheet

Chapter 2. Installation and Operation

2.1 INTRODUCTION

The MCP1640B is capable of regulating the output voltage over a wide 2.0V to 5.5V range, and typically can deliver over 100 mA of load current at 3.3V output when supplied from a single 1.2V cell. The input voltage range is 0.35V to 5.5V with a low 0.65V start-up voltage. The regulated output voltage (V_{OUT}) should be greater than or equal to the input voltage (V_{IN}). In particular, the MCP1640B is PWM-only with True Disconnect shutdown option.

The MCP16251 can regulate the output voltage over a 1.8V to 5.5V range, and can deliver a minimum of 75 mA of load current at 3.3V V_{OUT} when supplied from a one alkaline battery. Compared to the MCP1640B, the MCP16251 has both pulse-width modulation (PWM) and pulse frequency modulation (PFM) operating modes, and automatically selects the best operating mode for efficiency.

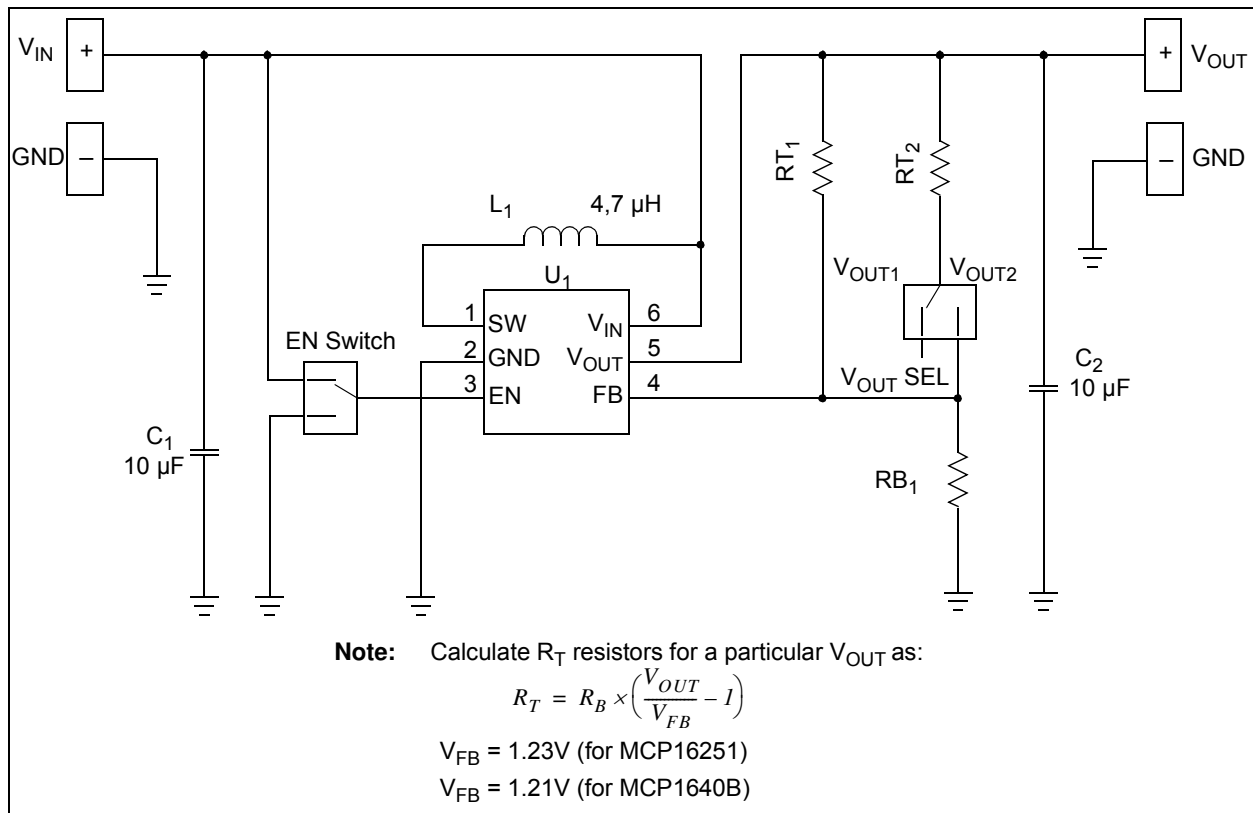

FIGURE 2-1: Synchronous Boost Application for SOT-23-6 package type.

When disabled, the True Disconnect option removes the normal boost topology path from input to output by opening the diode path, using a P-Channel synchronous switch with a reversible body diode.

The MCP16251 and MCP1640B Synchronous Boost Converters Evaluation Board offers both package types in two boost-converter applications for 2.0V, 3.3V and 5.0V output voltage options that can be selected using a mini-dip switch. The enable input is controlled in both boost converter applications using a mini-dip switch.

2.2 BOARD FEATURES

The MCP16251 and MCP1640B Synchronous Boost Converters Evaluation Board has the following features:

- It can be powered by one-cell, two-cell, or three-cell alkaline, NiCd, NiMH, one-cell Li-Ion or Li-Polymer batteries
- Input voltage range (V_{IN}): 0.35V to 5.5V, with $V_{IN} \leq V_{OUT}$
- Fixed output voltage: 2.0V or 3.3V and 3.3V or 5.0V, selected using a mini-dip switch on board
- Output current: typical 125 mA @ 3.3V Output, 1.5V Input or 200 mA @ 5.0V Output, 3V Input
- Start-up voltage: 0.82V (for MCP16251's Converter) or 0.65V (for MCP1640B's Converter) at $V_{OUT} = 3.3V$ and $I_{OUT} = 1mA$, resistive load
- Automatic PFM/PWM Operation for the MCP16251 Converter
- PWM Switching Frequency = 500 kHz
- Enable state, selectable using the mini-dip switch on board
- Peak Input Current Limit (800mA for MCP1640 or 650mA for MCP16251)
- Overtemperature Protection

2.3 GETTING STARTED

The MCP16251 and MCP1640B Synchronous Boost Converters Evaluation Board is fully assembled and tested to evaluate and demonstrate the MCP16251 and the MCP1640B products. This board requires the use of external lab supplies and load.

2.3.1 Power Input and Output Connection

2.3.1.1 POWERING THE MCP16251 AND MCP1640B SYNCHRONOUS BOOST CONVERTERS EVALUATION BOARD

Soldered test points are available for input voltage connections. The maximum input voltage should not exceed 6.0V. The output voltage will not remain in regulation for input voltages that are greater than or equal to the output voltage.

The MCP16251 and MCP1640B Synchronous Boost Converters Evaluation Board has two independent circuit applications, one using the MCP16251 SOT-23-6 package, while the other uses the MCP1640B DFN-8 package. The SOT-23-6 package has two output voltage settings (2.0V and 3.3V) selectable by an on-board mini-dip switch. The DFN-8 package has two output voltage settings (3.3V and 5.0V), also selectable by an on-board mini-dip switch.

Soldered test points are available to connect a load. The switch peak current limit will provide a safe maximum current value. The maximum output current for the converters will vary with input and output voltages; refer to the MCP16251/2 and MCP1640/B/C/D data sheets for more information on the maximum output current.

Installation and Operation

2.3.1.2 BOARD POWER-UP PROCEDURE

1. Connect system load to V_{OUT} and GND terminals; maximum load varies with input and output voltage (see the MCP16251/2 and MCP1640/B/C/D data sheets for more information on the maximum load). Connect the (+) side of the load to V_{OUT} and the negative (-) load to ground (GND).
2. Set the desired output voltage using the V_{OUT} SEL mini-dip switch.
3. Turn the device ON/OFF using the EN mini-dip switch.
4. When EN is set ON or high, the converter is enabled and V_{OUT} can be measured on the V_{OUT} and GND terminals. When EN is low, the converter is disabled and V_{OUT} is floating, and disconnected from the input.

Capacitors C_3 , C_4 , C_6 and C_7 are not populated. The component pads are provided for experimental use.

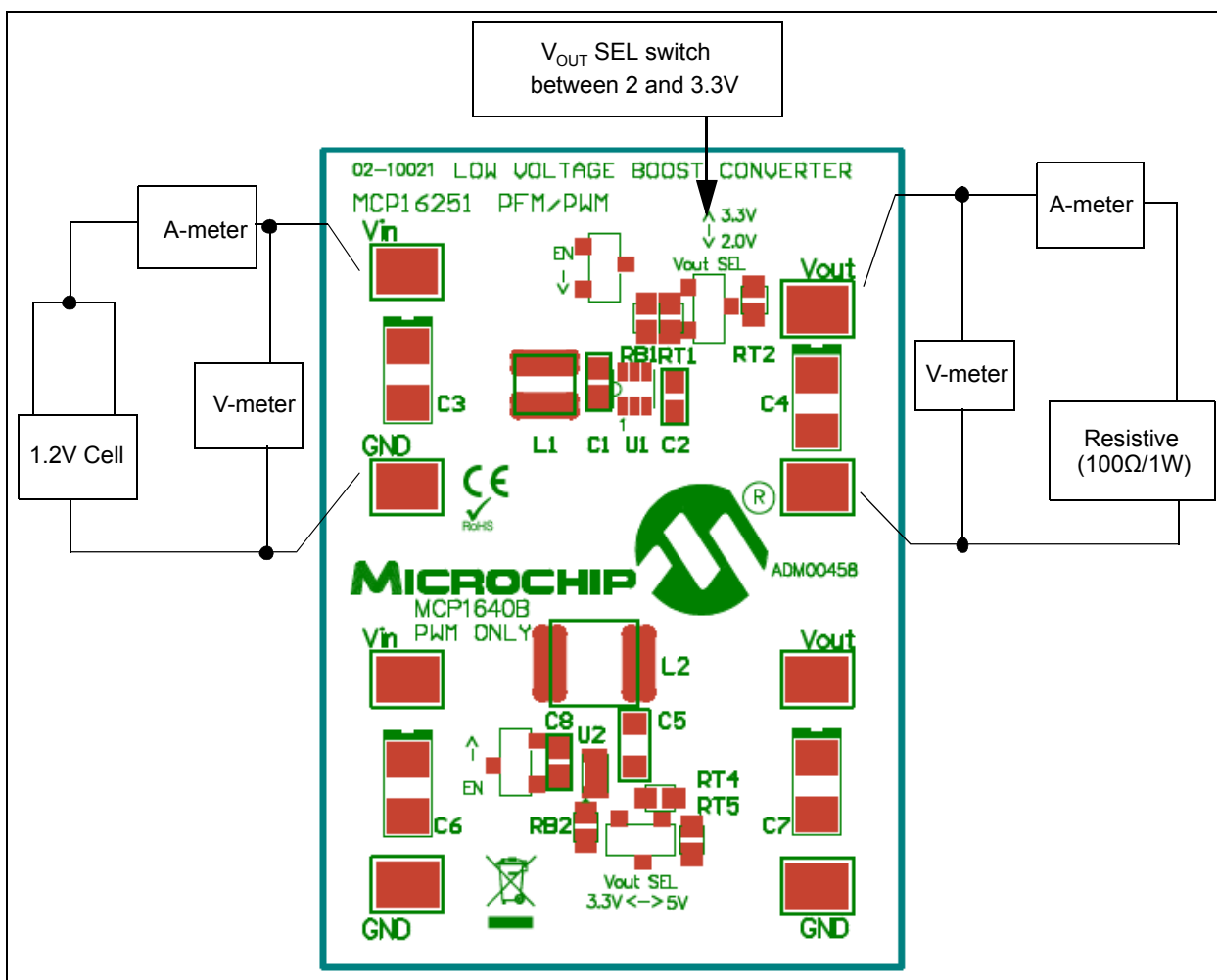

FIGURE 2-2: MCP16251 and MCP1640B Synchronous Boost Converters Evaluation Board Setup.

2.3.1.3 EN AND V_{OUT} SEL SWITCHES FUNCTION

Table 2-1 shows how the switches affect the functionality of the evaluation board.

TABLE 2-1: FUNCTION OF BOARD SWITCHES

State of Switches		V _{OUT} [V] for	
SW3 or SW4 EN Switch	SW1 or SW2 V _{OUT} SEL Switch	MCP16251T-E/CH SOT-23-6 Converter	MCP1640BT-I/MC 2x3 mm DFN Converter
ON	ON	2	3.3
ON	OFF	3.3	5
OFF	ON	0	0
OFF	OFF	0	0

Note that SW2 (V_{OUT} SEL) and SW4 (EN) are used for the SOT-23-6 circuit. Switches SW1 (V_{OUT} SEL) and SW3 (EN) are used for the 2x3 mm DFN-8 circuit.

2.3.1.4 ADJUSTABLE V_{OUT} SETTING

The resistor divider RT and RB are used to set the converter output voltage. By setting the V_{OUT} SEL switch in ON or OFF position, the output voltage can be calculated using the following equation:

EQUATION 2-1:

$$RT_1 = RB_1 \times \left[\left(\frac{V_{OUT}}{V_{FB}} \right) - 1 \right]$$

or

$$RT_4 = RB_2 \times \left[\left(\frac{V_{OUT}}{V_{FB}} \right) - 1 \right]$$

Where: V_{FB} = 1.21V for MCP1640B
V_{FB} = 1.23V for MCP16251

Note: If the feedback loop is recalculated, the V_{OUT} SEL switch will not be used, as it will add a resistor in parallel with the calculated component.



MCP16251 AND MCP1640B SYNCHRONOUS BOOST CONVERTERS EVALUATION BOARD USER'S GUIDE

Appendix A. Schematic and Layouts

A.1 INTRODUCTION

This appendix contains the following schematics and layouts for the MCP16251 and MCP1640B Synchronous Boost Converters Evaluation Board:

- Board – Schematic
- Board – Top Silk
- Board – Top Copper and Silk
- Board – Top Copper
- Board – Bottom Copper

A.2 BOARD – SCHEMATIC

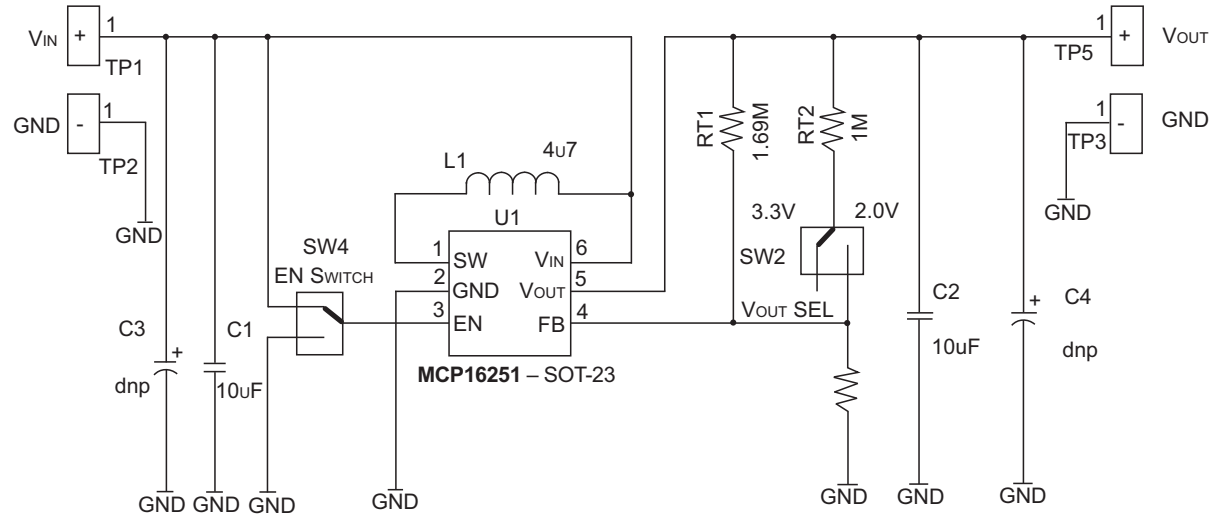

Note:
Calculate RT resistors
for a particular V_{OUT} as:

$$RT = RB * ((V_{out}/V_{FB}) - 1)$$

V_{FB} = 1.23V - MCP16251
V_{FB} = 1.21V - MCP1640B

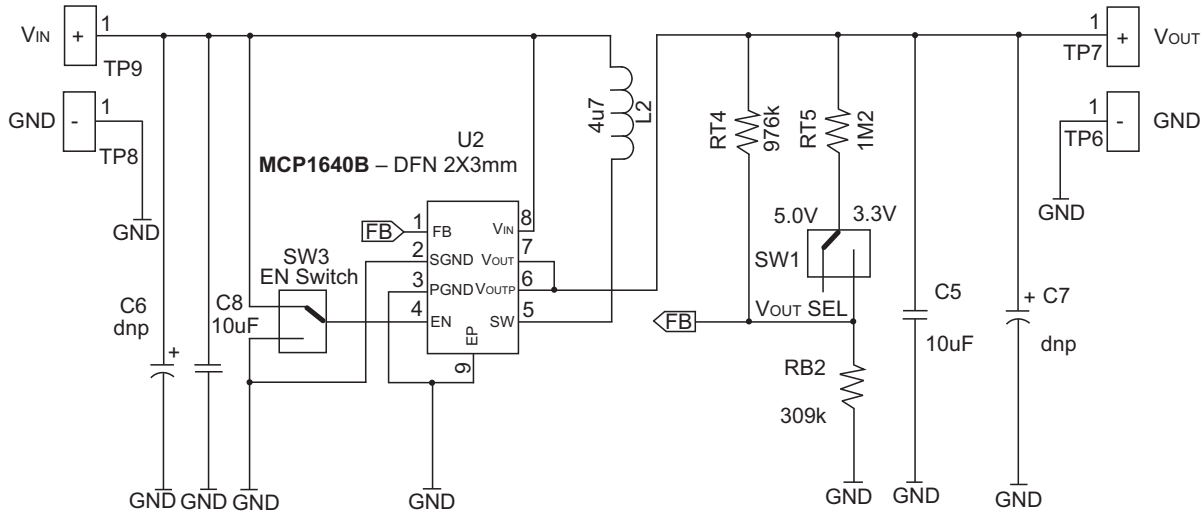

A.3 BOARD – TOP SILK

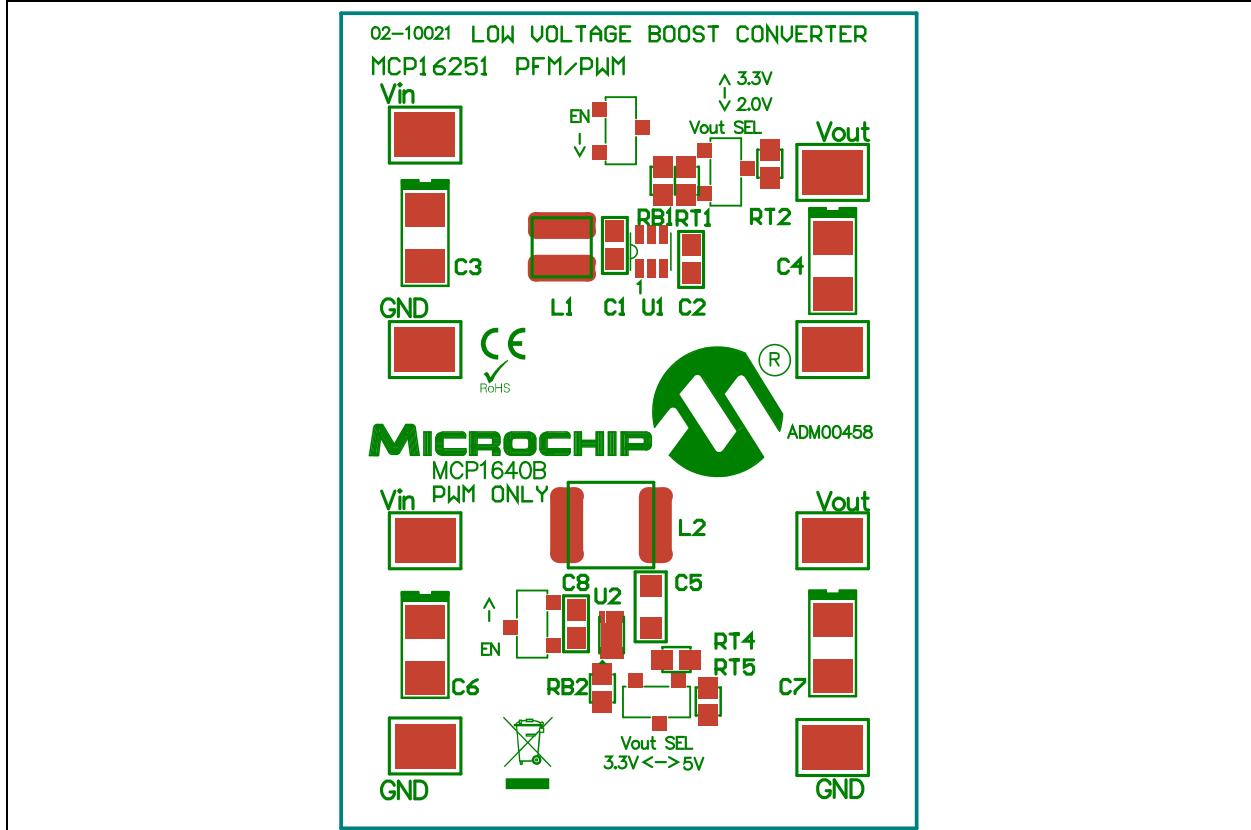

A.4 BOARD – TOP COPPER AND SILK

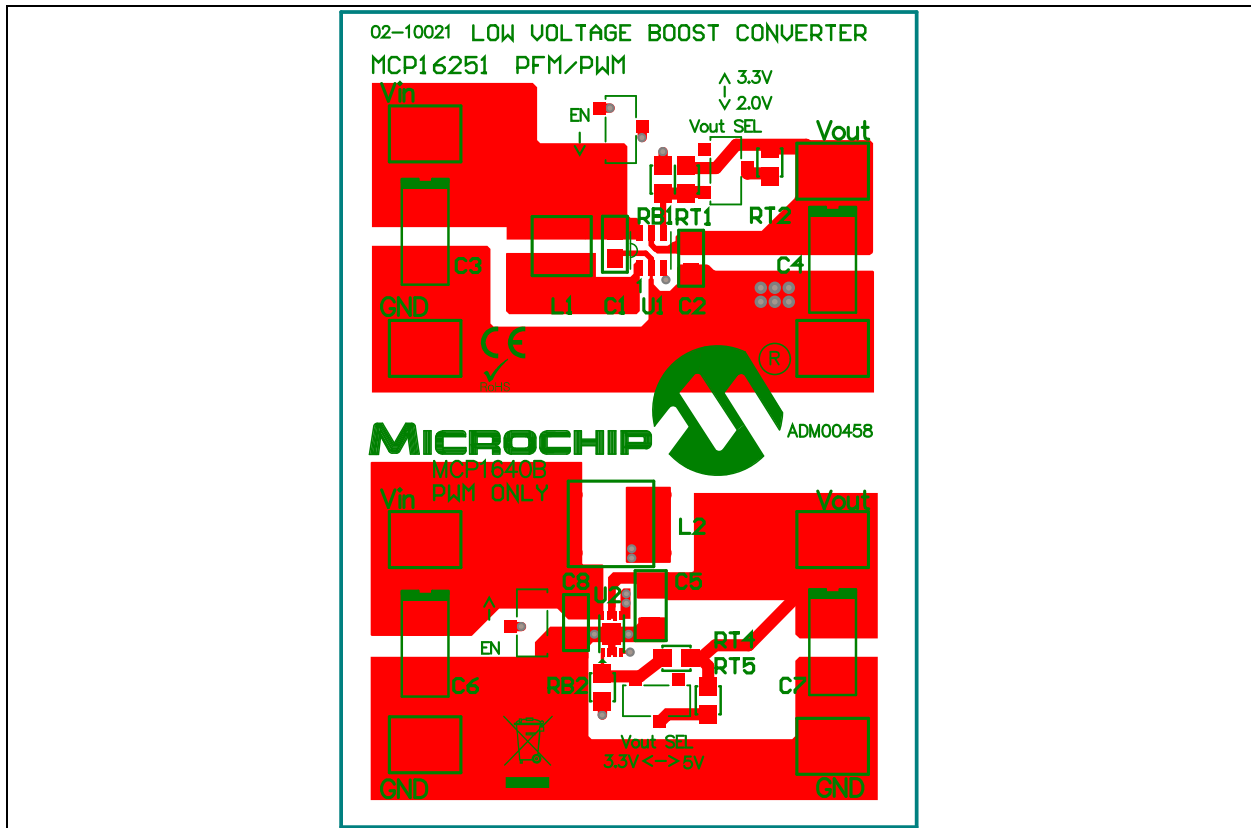

A.5 BOARD – TOP COPPER

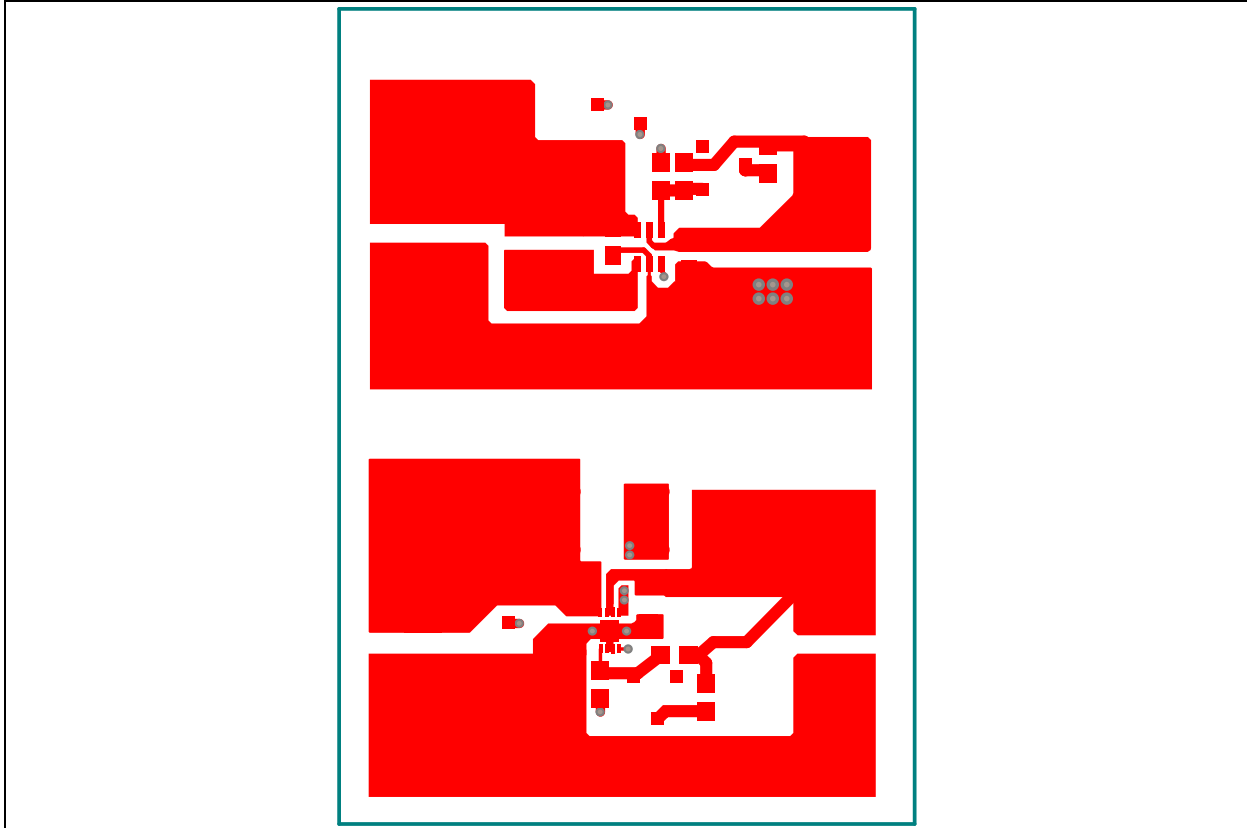

A.6 BOARD – BOTTOM COPPER

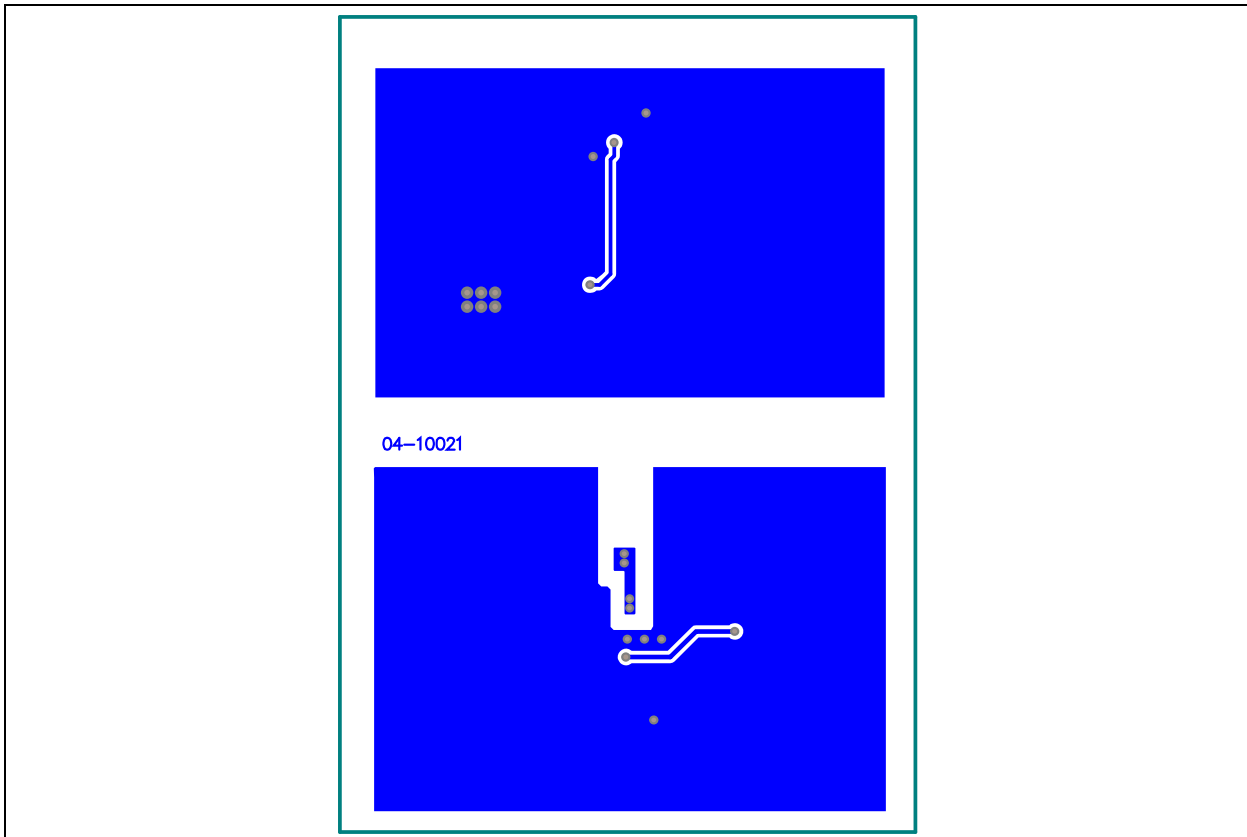



MCP16251 AND MCP1640B SYNCHRONOUS BOOST CONVERTERS EVALUATION BOARD USER'S GUIDE

Appendix B. Bill of Materials (BOM)

TABLE B-1: BILL OF MATERIALS (BOM)

Qty	Reference	Description	Manufacturer	Part Number
4	Bump	Bumpon Hemisphere 44X.20 white	3M	SJ-5003 (WHITE)
3	C1, C2, C8	Cap. ceramic 10 μ F 10V X7R 0805	Murata Electronics [®]	GRM21BR71A106KE51L
1	C5	Cap. ceramic 10 μ F 10V X7R 1206	Murata Electronics	GRM31CR71A106KA01L
1	L1	Inductor Power 4.7 μ H 1.55A SMD	Würth Electronics	744043004
1	L2	Inductor Power 4.7 μ H 2.0A SMD	EPCOS AG	B82462G4472M
	PCB	Printed Circuit Board – MCP16251 and MCP1640B Synchronous Boost Converters Evaluation Board	—	104-00458
2	RB1, RT2	Res. 1000 kOhm 1/8W 1% 0805 SMD	Panasonic [®] -ECG	ERJ-6ENF1004V
1	RB2	Res. 309 kOhm 1/8W 1% 0805 SMD	Panasonic-ECG	ERJ-6ENF3093V
1	RT1	Res. 1690 kOhm 1/8W 1% 0805 SMD	Yageo Corporation	RC0805FR-071M69L
1	RT4	Res. 976 kOhm 1/8W 1% 0805 SMD	Panasonic-ECG	ERJ-6ENF9763V
1	RT5	Res. 1.20 MOhm 1/8W 1% 0805 SMD	Rohm Semiconductor	MCR10EZHF1204
4	SW1, SW2, SW3, SW4	Switch slide SPDT SMD Gull	Nidec Copal Electronics Inc.	CJS-1200TB
8	TP1, TP2, TP3, TP5, TP6, TP7, TP8, TP9	PC test point compact SMT	Keystone Electronics Corp.	5016
1	U1	MCP16251 Synchronous Step-up DC-DC Converter, SOT-23	Microchip Technology inc.	MCP16251T-I/CH
1	U2	MCP1640B Synchronous Boost Converter, DFN 2x3 mm	Microchip Technology inc.	MCP1640BT-I/MC

Note 1: The components listed in this Bill of Materials are representative of the PCB assembly. The released BOM used in manufacturing uses all RoHS-compliant components.



MICROCHIP

Worldwide Sales and Service

AMERICAS

Corporate Office
2355 West Chandler Blvd.
Chandler, AZ 85224-6199
Tel: 480-792-7200
Fax: 480-792-7277
Technical Support:
<http://www.microchip.com/support>
Web Address:
www.microchip.com

Atlanta
Duluth, GA
Tel: 678-957-9614
Fax: 678-957-1455

Boston
Westborough, MA
Tel: 774-760-0087
Fax: 774-760-0088

Chicago
Itasca, IL
Tel: 630-285-0071
Fax: 630-285-0075

Cleveland
Independence, OH
Tel: 216-447-0464
Fax: 216-447-0643

Dallas
Addison, TX
Tel: 972-818-7423
Fax: 972-818-2924

Detroit
Farmington Hills, MI
Tel: 248-538-2250
Fax: 248-538-2260

Indianapolis
Noblesville, IN
Tel: 317-773-8323
Fax: 317-773-5453

Los Angeles
Mission Viejo, CA
Tel: 949-462-9523
Fax: 949-462-9608

Santa Clara
Santa Clara, CA
Tel: 408-961-6444
Fax: 408-961-6445

Toronto
Mississauga, Ontario,
Canada
Tel: 905-673-0699
Fax: 905-673-6509

ASIA/PACIFIC

Asia Pacific Office
Suites 3707-14, 37th Floor
Tower 6, The Gateway
Harbour City, Kowloon
Hong Kong
Tel: 852-2401-1200
Fax: 852-2401-3431

Australia - Sydney
Tel: 61-2-9868-6733
Fax: 61-2-9868-6755

China - Beijing
Tel: 86-10-8569-7000
Fax: 86-10-8528-2104

China - Chengdu
Tel: 86-28-8665-5511
Fax: 86-28-8665-7889

China - Chongqing
Tel: 86-23-8980-9588
Fax: 86-23-8980-9500

China - Hangzhou
Tel: 86-571-2819-3187
Fax: 86-571-2819-3189

China - Hong Kong SAR
Tel: 852-2943-5100
Fax: 852-2401-3431

China - Nanjing
Tel: 86-25-8473-2460
Fax: 86-25-8473-2470

China - Qingdao
Tel: 86-532-8502-7355
Fax: 86-532-8502-7205

China - Shanghai
Tel: 86-21-5407-5533
Fax: 86-21-5407-5066

China - Shenyang
Tel: 86-24-2334-2829
Fax: 86-24-2334-2393

China - Shenzhen
Tel: 86-755-8864-2200
Fax: 86-755-8203-1760

China - Wuhan
Tel: 86-27-5980-5300
Fax: 86-27-5980-5118

China - Xian
Tel: 86-29-8833-7252
Fax: 86-29-8833-7256

China - Xiamen
Tel: 86-592-2388138
Fax: 86-592-2388130

China - Zhuhai
Tel: 86-756-3210040
Fax: 86-756-3210049

ASIA/PACIFIC

India - Bangalore
Tel: 91-80-3090-4444
Fax: 91-80-3090-4123

India - New Delhi
Tel: 91-11-4160-8631
Fax: 91-11-4160-8632

India - Pune
Tel: 91-20-2566-1512
Fax: 91-20-2566-1513

Japan - Osaka
Tel: 81-6-6152-7160
Fax: 81-6-6152-9310

Japan - Tokyo
Tel: 81-3-6880-3770
Fax: 81-3-6880-3771

Korea - Daegu
Tel: 82-53-744-4301
Fax: 82-53-744-4302

Korea - Seoul
Tel: 82-2-554-7200
Fax: 82-2-558-5932 or
82-2-558-5934

Malaysia - Kuala Lumpur
Tel: 60-3-6201-9857
Fax: 60-3-6201-9859

Malaysia - Penang
Tel: 60-4-227-8870
Fax: 60-4-227-4068

Philippines - Manila
Tel: 63-2-634-9065
Fax: 63-2-634-9069

Singapore
Tel: 65-6334-8870
Fax: 65-6334-8850

Taiwan - Hsin Chu
Tel: 886-3-5778-366
Fax: 886-3-5770-955

Taiwan - Kaohsiung
Tel: 886-7-213-7828
Fax: 886-7-330-9305

Taiwan - Taipei
Tel: 886-2-2508-8600
Fax: 886-2-2508-0102

Thailand - Bangkok
Tel: 66-2-694-1351
Fax: 66-2-694-1350

EUROPE

Austria - Wels
Tel: 43-7242-2244-39
Fax: 43-7242-2244-393

Denmark - Copenhagen
Tel: 45-4450-2828
Fax: 45-4485-2829

France - Paris
Tel: 33-1-69-53-63-20
Fax: 33-1-69-30-90-79

Germany - Munich
Tel: 49-89-627-144-0
Fax: 49-89-627-144-44

Italy - Milan
Tel: 39-0331-742611
Fax: 39-0331-466781

Netherlands - Drunen
Tel: 31-416-690399
Fax: 31-416-690340

Spain - Madrid
Tel: 34-91-708-08-90
Fax: 34-91-708-08-91

UK - Wokingham
Tel: 44-118-921-5869
Fax: 44-118-921-5820

11/29/12