



Chipsmall Limited consists of a professional team with an average of over 10 year of expertise in the distribution of electronic components. Based in Hongkong, we have already established firm and mutual-benefit business relationships with customers from,Europe,America and south Asia,supplying obsolete and hard-to-find components to meet their specific needs.

With the principle of “Quality Parts,Customers Priority,Honest Operation,and Considerate Service”,our business mainly focus on the distribution of electronic components. Line cards we deal with include Microchip,ALPS,ROHM,Xilinx,Pulse,ON,Everlight and Freescale. Main products comprise IC,Modules,Potentiometer,IC Socket,Relay,Connector.Our parts cover such applications as commercial,industrial, and automotives areas.

We are looking forward to setting up business relationship with you and hope to provide you with the best service and solution. Let us make a better world for our industry!



Contact us

Tel: +86-755-8981 8866 Fax: +86-755-8427 6832

Email & Skype: info@chipsmall.com Web: www.chipsmall.com

Address: A1208, Overseas Decoration Building, #122 Zhenhua RD., Futian, Shenzhen, China





MICROCHIP

**MCP1663
9V/12V/24V Output
Boost Regulator
Evaluation Board
User's Guide**

Note the following details of the code protection feature on Microchip devices:

- Microchip products meet the specification contained in their particular Microchip Data Sheet.
- Microchip believes that its family of products is one of the most secure families of its kind on the market today, when used in the intended manner and under normal conditions.
- There are dishonest and possibly illegal methods used to breach the code protection feature. All of these methods, to our knowledge, require using the Microchip products in a manner outside the operating specifications contained in Microchip's Data Sheets. Most likely, the person doing so is engaged in theft of intellectual property.
- Microchip is willing to work with the customer who is concerned about the integrity of their code.
- Neither Microchip nor any other semiconductor manufacturer can guarantee the security of their code. Code protection does not mean that we are guaranteeing the product as "unbreakable."

Code protection is constantly evolving. We at Microchip are committed to continuously improving the code protection features of our products. Attempts to break Microchip's code protection feature may be a violation of the Digital Millennium Copyright Act. If such acts allow unauthorized access to your software or other copyrighted work, you may have a right to sue for relief under that Act.

Information contained in this publication regarding device applications and the like is provided only for your convenience and may be superseded by updates. It is your responsibility to ensure that your application meets with your specifications. MICROCHIP MAKES NO REPRESENTATIONS OR WARRANTIES OF ANY KIND WHETHER EXPRESS OR IMPLIED, WRITTEN OR ORAL, STATUTORY OR OTHERWISE, RELATED TO THE INFORMATION, INCLUDING BUT NOT LIMITED TO ITS CONDITION, QUALITY, PERFORMANCE, MERCHANTABILITY OR FITNESS FOR PURPOSE. Microchip disclaims all liability arising from this information and its use. Use of Microchip devices in life support and/or safety applications is entirely at the buyer's risk, and the buyer agrees to defend, indemnify and hold harmless Microchip from any and all damages, claims, suits, or expenses resulting from such use. No licenses are conveyed, implicitly or otherwise, under any Microchip intellectual property rights.

Trademarks

The Microchip name and logo, the Microchip logo, dsPIC, FlashFlex, flexPWR, JukeBlox, KEELOQ, KEELOQ logo, Kleer, LANCheck, MediaLB, MOST, MOST logo, MPLAB, OptoLyzer, PIC, PICSTART, PIC³² logo, RightTouch, SpyNIC, SST, SST Logo, SuperFlash and UNI/O are registered trademarks of Microchip Technology Incorporated in the U.S.A. and other countries.

The Embedded Control Solutions Company and mTouch are registered trademarks of Microchip Technology Incorporated in the U.S.A.

Analog-for-the-Digital Age, BodyCom, chipKIT, chipKIT logo, CodeGuard, dsPICDEM, dsPICDEM.net, ECAN, In-Circuit Serial Programming, ICSP, Inter-Chip Connectivity, KleerNet, KleerNet logo, MiWi, MPASM, MPF, MPLAB Certified logo, MPLIB, MPLINK, MultiTRAK, NetDetach, Omniscient Code Generation, PICDEM, PICDEM.net, PICkit, PICtail, RightTouch logo, REAL ICE, SQI, Serial Quad I/O, Total Endurance, TSHARC, USBCheck, VariSense, ViewSpan, WiperLock, Wireless DNA, and ZENA are trademarks of Microchip Technology Incorporated in the U.S.A. and other countries.

SQTP is a service mark of Microchip Technology Incorporated in the U.S.A.

Silicon Storage Technology is a registered trademark of Microchip Technology Inc. in other countries.

GestIC is a registered trademarks of Microchip Technology Germany II GmbH & Co. KG, a subsidiary of Microchip Technology Inc., in other countries.

All other trademarks mentioned herein are property of their respective companies.

© 2015, Microchip Technology Incorporated, Printed in the U.S.A., All Rights Reserved.

ISBN: 978-1-63277-406-4

**QUALITY MANAGEMENT SYSTEM
CERTIFIED BY DNV
= ISO/TS 16949 =**

Microchip received ISO/TS-16949:2009 certification for its worldwide headquarters, design and wafer fabrication facilities in Chandler and Tempe, Arizona; Gresham, Oregon and design centers in California and India. The Company's quality system processes and procedures are for its PIC[®] MCUs and dsPIC[®] DSCs, KEELOQ[®] code hopping devices, Serial EEPROMs, microperipherals, nonvolatile memory and analog products. In addition, Microchip's quality system for the design and manufacture of development systems is ISO 9001:2000 certified.

Object of Declaration: MCP1663 9V/12V/24V Output Boost Regulator Evaluation Board

EU Declaration of Conformity

Manufacturer: Microchip Technology Inc.
2355 W. Chandler Blvd.
Chandler, Arizona, 85224-6199
USA

This declaration of conformity is issued by the manufacturer.

The development/evaluation tool is designed to be used for research and development in a laboratory environment. This development/evaluation tool is not a Finished Appliance, nor is it intended for incorporation into Finished Appliances that are made commercially available as single functional units to end users under EU EMC Directive 2004/108/EC and as supported by the European Commission's Guide for the EMC Directive 2004/108/EC (8th February 2010).

This development/evaluation tool complies with EU RoHS2 Directive 2011/65/EU.

This development/evaluation tool, when incorporating wireless and radio-telecom functionality, is in compliance with the essential requirement and other relevant provisions of the R&TTE Directive 1999/5/EC and the FCC rules as stated in the declaration of conformity provided in the module datasheet and the module product page available at www.microchip.com.

For information regarding the exclusive, limited warranties applicable to Microchip products, please see Microchip's standard terms and conditions of sale, which are printed on our sales documentation and available at www.microchip.com.

Signed for and on behalf of Microchip Technology Inc. at Chandler, Arizona, USA

Derek Carlson
VP Development Tools

12-Sep-14
Date

NOTES:



MCP1663 9V/12V/24V OUTPUT BOOST REGULATOR EVALUATION BOARD USER'S GUIDE

Table of Contents

Preface	7
Introduction.....	7
Document Layout	7
Conventions Used in this Guide	8
Recommended Reading.....	9
The Microchip Web Site	9
Customer Support	9
Document Revision History	9
Chapter 1. Product Overview	
1.1 Introduction	11
1.2 MCP1663 Device Overview	11
1.3 What is the MCP1663 9V/12V/24V Output Boost Regulator Evaluation Board?	13
1.4 What the MCP1663 9V/12V/24V Output Boost Regulator Evaluation Board Kit Contains	13
Chapter 2. Installation and Operation	
2.1 Introduction	15
2.2 Getting Started	17
2.3 Test Results for Typical Application using MCP1663	19
2.4 Battery Considerations	22
Appendix A. Schematic and Layouts	
A.1 Introduction	23
A.2 Board – Schematic	24
A.3 Board – Top Silk And Pads	25
A.4 Board – Top Silk And Copper	26
A.5 Board – Top Copper	27
A.6 Board – Bottom Copper	28
Appendix B. Bill of Materials (BOM)	29
Worldwide Sales and Service	32

NOTES:



MCP1663 9V/12V/24V OUTPUT BOOST REGULATOR EVALUATION BOARD USER'S GUIDE

Preface

NOTICE TO CUSTOMERS

All documentation becomes dated, and this manual is no exception. Microchip tools and documentation are constantly evolving to meet customer needs, so some actual dialogs and/or tool descriptions may differ from those in this document. Please refer to our web site (www.microchip.com) to obtain the latest documentation available.

Documents are identified with a “DS” number. This number is located on the bottom of each page, in front of the page number. The numbering convention for the DS number is “DSXXXXXXA”, where “XXXXXX” is the document number and “A” is the revision level of the document.

For the most up-to-date information on development tools, see the MPLAB® IDE online help. Select the Help menu, and then Topics to open a list of available online help files.

INTRODUCTION

This chapter contains general information that will be useful to know before using the MCP1663 9V/12V/24V Output Boost Regulator Evaluation Board. Items discussed in this chapter include:

- Document Layout
- Conventions Used in this Guide
- Recommended Reading
- The Microchip Web Site
- Customer Support
- Document Revision History

DOCUMENT LAYOUT

This document describes how to use the MCP1663 9V/12V/24V Output Boost Regulator Evaluation Board as a development tool. The manual layout is as follows:

- **Chapter 1. “Product Overview”** – Important information about the MCP1663 9V/12V/24V Output Boost Regulator Evaluation Board.
- **Chapter 2. “Installation and Operation”** – Includes instructions on how to get started with the MCP1663 9V/12V/24V Output Boost Regulator Evaluation Board and a description of the user’s guide.
- **Appendix A. “Schematic and Layouts”** – Shows the schematic and layout diagrams for the MCP1663 9V/12V/24V Output Boost Regulator Evaluation Board.
- **Appendix B. “Bill of Materials (BOM)”** – Lists the parts used to build the MCP1663 9V/12V/24V Output Boost Regulator Evaluation Board.

CONVENTIONS USED IN THIS GUIDE

This manual uses the following documentation conventions:

DOCUMENTATION CONVENTIONS

Description	Represents	Examples
Arial font:		
Italic characters	Referenced books	<i>MPLAB[®] IDE User's Guide</i>
	Emphasized text	...is the <i>only</i> compiler...
Initial caps	A window	the Output window
	A dialog	the Settings dialog
	A menu selection	select Enable Programmer
Quotes	A field name in a window or dialog	"Save project before build"
Underlined, italic text with right angle bracket	A menu path	<u><i>File>Save</i></u>
Bold characters	A dialog button	Click OK
	A tab	Click the Power tab
N'Rnnnn	A number in verilog format, where N is the total number of digits, R is the radix and n is a digit.	4'b0010, 2'hF1
Text in angle brackets < >	A key on the keyboard	Press <Enter>, <F1>
Courier New font:		
Plain Courier New	Sample source code	#define START
	Filenames	autoexec.bat
	File paths	c:\mcc18\h
	Keywords	_asm, _endasm, static
	Command-line options	-Opa+, -Opa-
	Bit values	0, 1
	Constants	0xFF, 'A'
Italic Courier New	A variable argument	<i>file.o</i> , where <i>file</i> can be any valid filename
Square brackets []	Optional arguments	mcc18 [options] <i>file</i> [options]
Curly brackets and pipe character: { }	Choice of mutually exclusive arguments; an OR selection	errorlevel {0 1}
Ellipses...	Replaces repeated text	var_name [, var_name...]
	Represents code supplied by user	void main (void) { ... }

RECOMMENDED READING

This user's guide describes how to use MCP1663 9V/12V/24V Output Boost Regulator Evaluation Board. Another useful document is listed below. The following Microchip document is available and recommended as a supplemental reference resource.

- **MCP1663 Data Sheet - “High-Voltage Integrated Switch PWM Boost Regulator with UVLO” (DS20005406)**

THE MICROCHIP WEB SITE

Microchip provides online support via our web site at www.microchip.com. This web site is used as a means to make files and information easily available to customers. Accessible by using your favorite Internet browser, the web site contains the following information:

- **Product Support** – Data sheets and errata, application notes and sample programs, design resources, user's guides and hardware support documents, latest software releases and archived software
- **General Technical Support** – Frequently Asked Questions (FAQs), technical support requests, online discussion groups, Microchip consultant program member listing
- **Business of Microchip** – Product selector and ordering guides, latest Microchip press releases, listing of seminars and events, listings of Microchip sales offices, distributors and factory representatives

CUSTOMER SUPPORT

Users of Microchip products can receive assistance through several channels:

- Distributor or Representative
- Local Sales Office
- Field Application Engineer (FAE)
- Technical Support

Customers should contact their distributor, representative or field application engineer (FAE) for support. Local sales offices are also available to help customers. A listing of sales offices and locations is included in the back of this document.

Technical support is available through the web site at:
<http://www.microchip.com/support>.

DOCUMENT REVISION HISTORY

Revision A (May 2015)

- Initial Release of this Document.

NOTES:

Chapter 1. Product Overview

1.1 INTRODUCTION

This chapter provides an overview of the MCP1663 9V/12V/24V Output Boost Regulator Evaluation Board and covers the following topics:

- MCP1663 Short Overview
- What is the MCP1663 9V/12V/24V Output Boost Regulator Evaluation Board?
- What the MCP1663 9V/12V/24V Output Boost Regulator Evaluation Board Contains

1.2 MCP1663 DEVICE OVERVIEW

The MCP1663 is a compact, high-efficiency, fixed-frequency, non-synchronous step-up DC/DC converter which integrates a 36V, 400 mΩ switch. This product provides a space-efficient high voltage step-up, easy-to-use power supply solution. The MCP1663 was developed for applications powered by two-cell or three-cell alkaline, Energizer® Lithium Primary, Ni-Cd, Ni-MH batteries, or Li-Ion or Li-Polymer batteries.

The MCP1663 operates in Pulse-Width Modulation (PWM), at a fixed 500 kHz switching frequency. The device features an under-voltage lockout (UVLO) which prevents fault operation below 1.85V (UVLO_{STOP}) corresponding to the value of two discharged batteries. The MCP1663 starts its normal operation at 2.3V input voltage (UVLO_{START}) and the operating input voltage ranges from 2.4V to 5.5V.

For standby applications, MCP1663 can be put in Shutdown by pulling the EN pin to GND. The device will stop switching and will consume a few μA of input current (including feedback divider current; the device consumes 300 nA typical). In the Boost configuration, the input voltage will be bypassed to output through the inductor and Schottky diode.

MCP1663 also provides over-voltage protection (OVP) in the event of:

- Short-circuit of the feedback pin to GND
- Disconnected feedback divider

In these conditions, the OVP function will stop the internal driver and prevent damage to the device. This feature is disabled during the start-up sequence and Thermal Shutdown state.

The goal of the MCP1663 9V/12V/24V Output Boost Regulator Evaluation Board is to demonstrate the higher output voltage and output current capabilities of the MCP1663 Boost Converter.

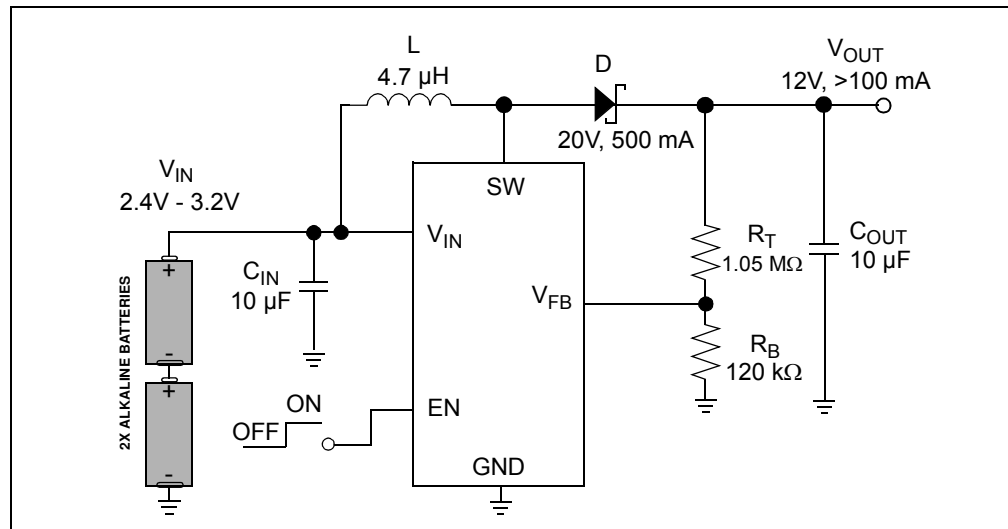

FIGURE 1-1: Typical MCP1663 Boost Converter Two Alkaline Cells Input.

1.2.1 HIGH INPUT VOLTAGE CONFIGURATION

The MCP1663 9V/12V/24V Output Boost Regulator Evaluation Board comes with two additional configurations that can be used to extend and overcome the typical low V_{IN} voltage range, providing significantly more flexibility for applications powered from a higher input. The MCP1663 high-input voltage boost converter (the bottom circuit on the evaluation board) comes with two different solutions that can be used to extend the application's input voltage range beyond its typical values. For this circuit, V_{IN} represents the voltage applied between the V_{IN} and GND test points on the board and V_{DD} represents the voltage that will be present on the MCP1663 input pin.

- The first option used for driving the MCP1663's low input (V_{DD}) voltage internal circuitry is to use a linear dropout regulator (LDO) to step-down the application supply voltage (V_{IN}) to 5V.
- The second solution to limit the V_{IN} voltage is to use a Zener diode regulator.

The MCP1663 low input quiescent current keeps the LDO and the Zener diode circuitry power losses at a low level.

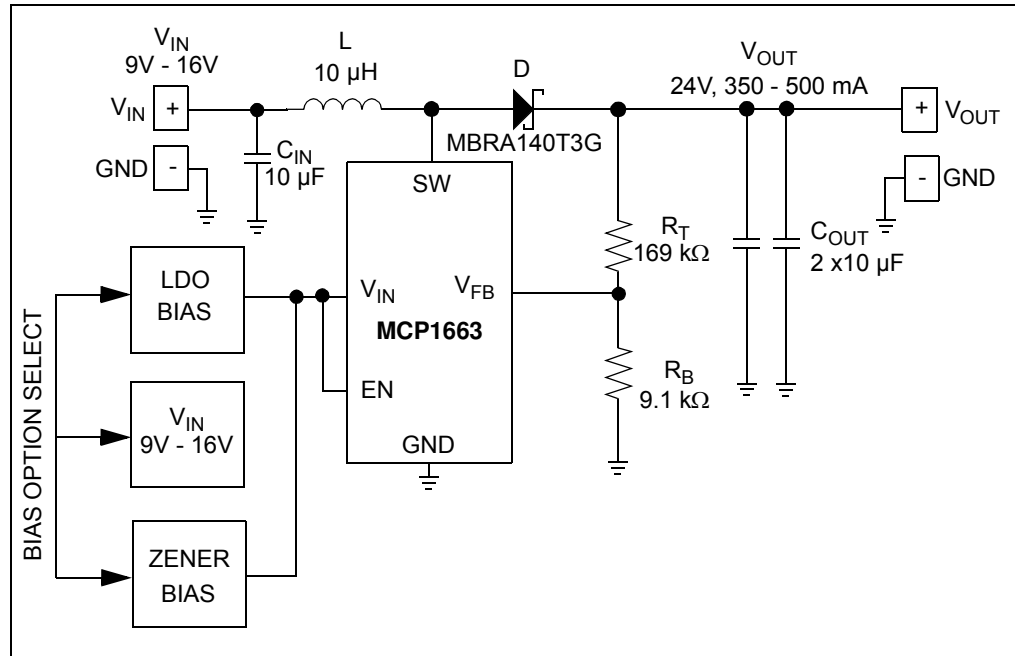

FIGURE 1-2: MCP1663 24V Output Boost from HV Input (9V-16V).

1.3 WHAT IS THE MCP1663 9V/12V/24V OUTPUT BOOST REGULATOR EVALUATION BOARD?

The MCP1663 9V/12V/24V Output Boost Regulator Evaluation Board is used to evaluate and demonstrate Microchip Technology's MCP1663 Switching Boost Regulator. This board demonstrates the MCP1663 capabilities in two different applications:

- 9V or 12V selectable output Boost Converter application supplied from an external voltage source ($V_{IN} < 5.5V$ e.g. Li-Ion cell boost to 9V or 12V). This typical step-up configuration is meant to highlight the MCP1663 basic boost operation.
- 24V Output Boost converter application supplied from high voltage input rail (e.g. 9V - 16V). This application provides solutions for the particular situation in which the required input voltage is outside the typical operating range (e.g. $V_{IN} = 12V$ boost to 24V Output). J1 jumper is used to choose between stepping down the V_{IN} voltage using the LDO or the Zener diode circuitry.

The board can be used to evaluate the SOT-23-5 lead package. The MCP1663 9V/12V/24V Output Boost Regulator Evaluation Board was developed to help engineers reduce product design cycle time.

The output voltage is set to the proper value using an external resistor divider, resulting in a simple and compact solution.

1.4 WHAT THE MCP1663 9V/12V/24V OUTPUT BOOST REGULATOR EVALUATION BOARD KIT CONTAINS

This MCP1663 9V/12V/24V Output Boost Regulator Evaluation Board kit includes:

- MCP1663 9V/12V/24V Output Boost Regulator Evaluation Board (ADM00664)
- Information Sheet

NOTES:

Chapter 2. Installation and Operation

2.1 INTRODUCTION

MCP1663 is a non-synchronous, fixed-frequency step-up DC/DC converter which has been developed for applications that require higher output voltage capabilities.

MCP1663 can regulate the output voltage up to 32V and can deliver up to 250 mA load at 3.3V input and 12V output (see [Figure 2-3](#)). At light loads, MCP1663 skips pulses to keep the output ripple low. The regulated output voltage (V_{OUT}) should be greater than the input voltage (V_{IN}).

Another important feature is that the device integrates the compensation and protection circuitry, such that the final solution lowers total system cost, eases implementation and requires a minimum number of additional components and board area.

2.1.1 MCP1663 9V/12V/24V Output Boost Regulator Evaluation Board Features

The MCP1663 9V/12V/24V Output Boost Regulator Evaluation Board has the following features:

- MCP1663 device can be evaluated in two separate applications:
 - Typical 9V/12V Output supplied from low-input voltage source**
 - Input Voltage range (V_{IN}): 2.4V to 5.5V, with $V_{IN} \leq V_{OUT}$
 - Output Current: typical 250 mA @ 12V Output, 3.3V Input
 - Enable state selectable using EN switch
 - 24V Output supplied from high input voltage source**
 - Input Voltage range (V_{IN}): 9V to 16V
- Undervoltage Lockout (UVLO)
 - UVLO Start: 2.3V
 - UVLO Stop: 1.85V
- PWM Operation
- PWM Switching Frequency: 500 kHz
- Peak Input Current Limit of 1.8A (typical)
- Internal Compensation
- Soft Start
- Protection in case of feedback pin shorted to GND
- Overtemperature Protection (if the die temperature exceeds +150°C, with 15°C hysteresis)

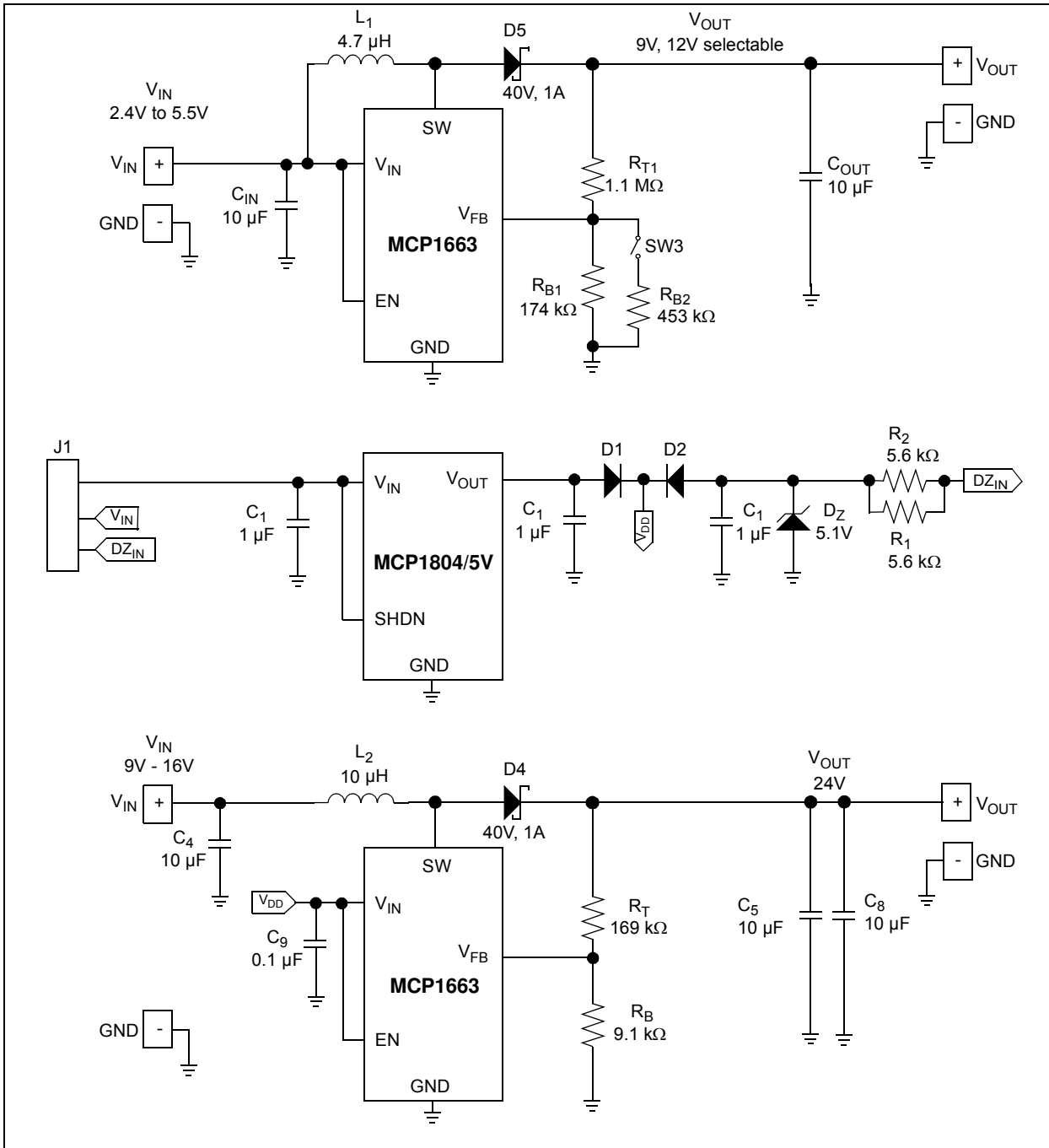

FIGURE 2-1: MCP1663 Evaluation Board Schematic.

2.2 GETTING STARTED

The MCP1663 9V/12V/24V Output Boost Regulator Evaluation Board is fully assembled and tested to evaluate and demonstrate the MCP1663 product. This board requires the use of external laboratory supplies and load.

2.2.1 Power Input and Output Connection

2.2.1.1 POWERING THE MCP1663 9V/12V/24V OUTPUT BOOST REGULATOR EVALUATION BOARD

The MCP1663 9V/12V/24V Output Boost Regulator Evaluation Board was designed to be used to evaluate the MCP1663 device. The package selected is SOT-23.

Soldered test points are available for input voltage connections.

Soldered test points are available to connect a load. The switch peak current limit will provide a safe maximum current value. The maximum output current for the converter will vary with input and output voltages; refer to [Figure 2-3](#) or the MCP1663 data sheet for more information on the maximum output current.

2.2.1.2 BOARD POWER-UP PROCEDURE

TOP CIRCUIT

1. Connect the input supply as shown in [Figure 2-2](#). The input voltage should not be higher than 5.5V.
2. Connect system load to V_{OUT} and GND terminals; maximum load varies with input and output voltage. Connect the (+) side of the load to V_{OUT} and the negative (-) load to ground (GND).
3. The "VOUT SELECT" switch can be used to modify the output voltage between two values:
 - 9V, when the switch is in OFF position
 - 12V, when the switch is in ON position

BOTTOM CIRCUIT

1. Connect the input supply as shown in [Figure 2-2](#).
2. The MCP1663 can be used in the extended input voltage range 9V - 16V.
3. Connect system load to V_{OUT} and GND terminals; maximum load varies with input and output voltage. Typically, the MCP1663 can supply a 24V output with 500 mA from a 12V input source at room temperature. Connect the (+) side of the load to V_{OUT} and the negative (-) load to ground (GND).
4. There are two distinct methods that can be used to extend the input voltage range:
 - Using an LDO to provide the necessary low voltage (V_{DD}) bias (jumper on J1 in "LDO" position)
 - Using a Zener diode (jumper on J1 in "Zener" position)

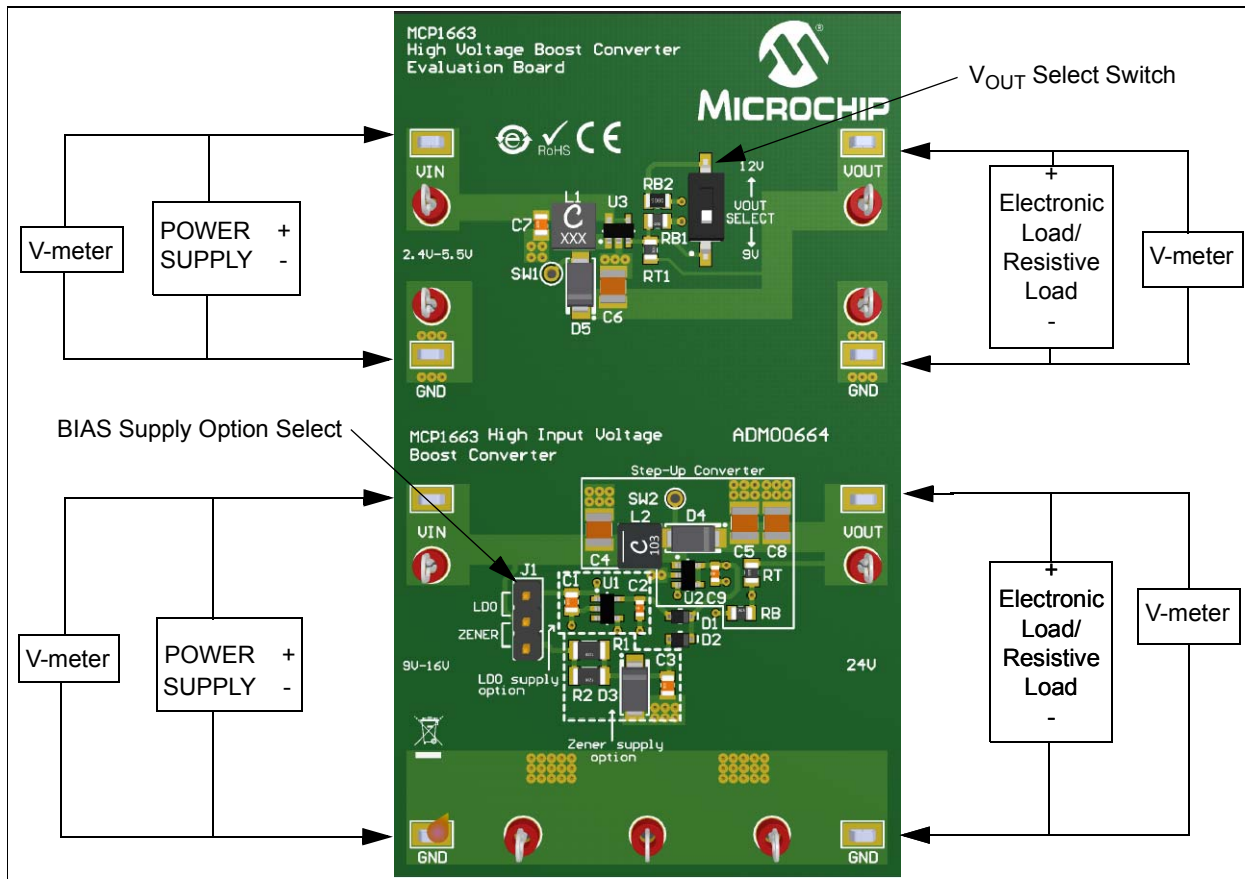

FIGURE 2-2: MCP1663 9V/12V/24V Output Boost Regulator Evaluation Board Setup.

2.2.1.3 ADJUSTABLE V_{OUT} SETTING

The top circuit comes with the output value set to 9V and 12V (V_{OUT} selective using a switch). If a different output is desired, set the switch in the OFF state (button down) and recalculate the resistor divider (RT1 and RB1) using Equation 2-1.

The Bottom circuit comes with V_{OUT} set to 24V. As in the previous case, the same equation can be used to calculate RT and RB and set another output voltage. Note that V_{IN} must be lower than V_{OUT} .

EQUATION 2-1:

$$RT = RB \times \left[\left(\frac{V_{OUT}}{V_{FB}} \right) - 1 \right]$$

Where: $V_{FB} = 1.227V$

Installation and Operation

For output voltages higher than 15V, the inductor value should be increased. See [Table 2-1](#) for more information.

TABLE 2-1: RECOMMENDED RESISTOR DIVIDER AND INDUCTOR VALUES

V _{OUT}	Inductor Value	RT	RB
6.0V	4.7 μ H	1050 k Ω	270 k Ω
9.0V	4.7 μ H	1000 k Ω	160 k Ω
12V	4.7 μ H	1050 k Ω	120 k Ω
24V	10 μ H	1050 k Ω	56 k Ω
32V	10 μ H	1100 k Ω	43 k Ω

2.3 TEST RESULTS FOR TYPICAL APPLICATION USING MCP1663

2.3.1 Test Results for MCP1663 - TOP Circuit

This chapter provides specific operation waveforms and graphs. Refer to the MCP1663 Data Sheet (DS20005406) for more information.

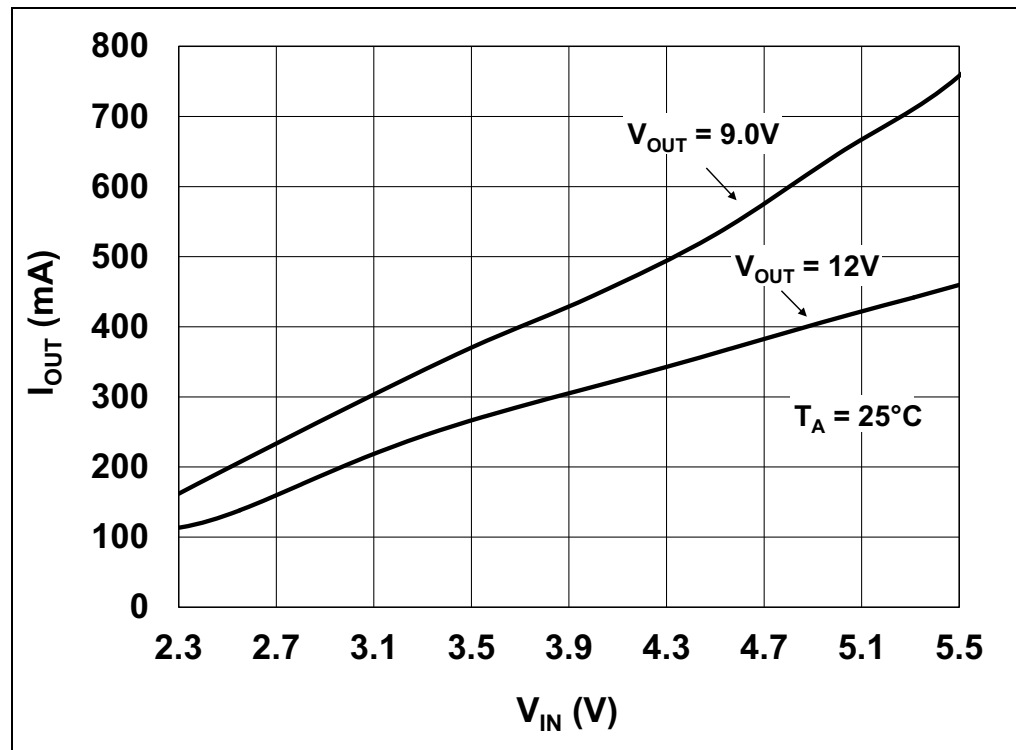

FIGURE 2-3: MCP1663 Boost - 9V and 12.0 V_{OUT} Maximum I_{OUT} vs. V_{IN} with Maximum 5% Output Drop.

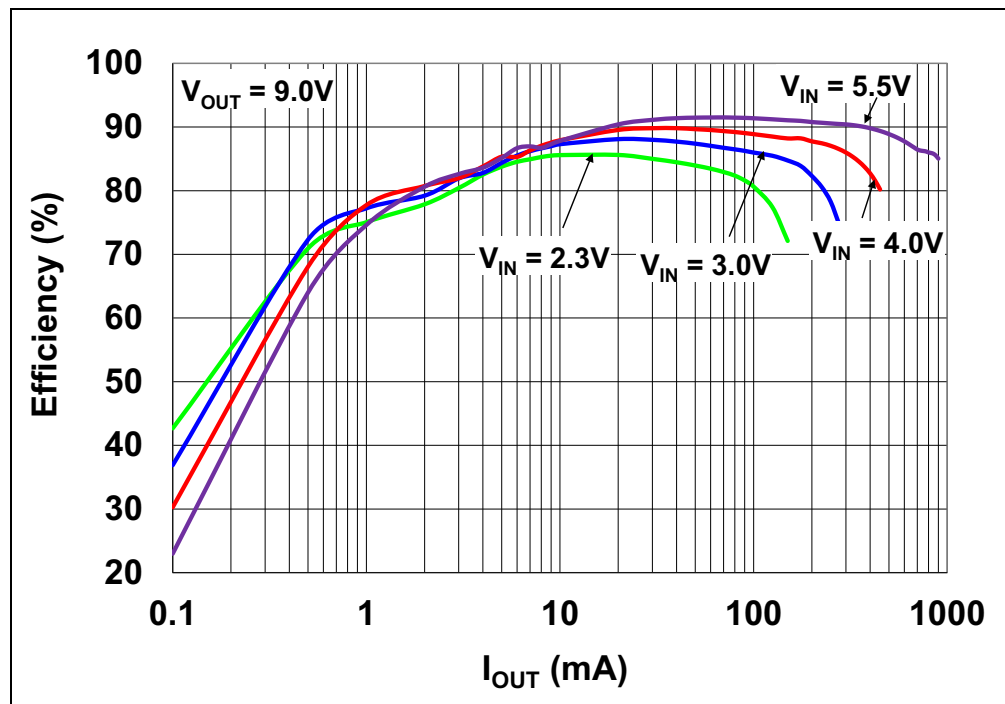

FIGURE 2-4: MCP1663 9V Output Efficiency vs. I_{OUT}

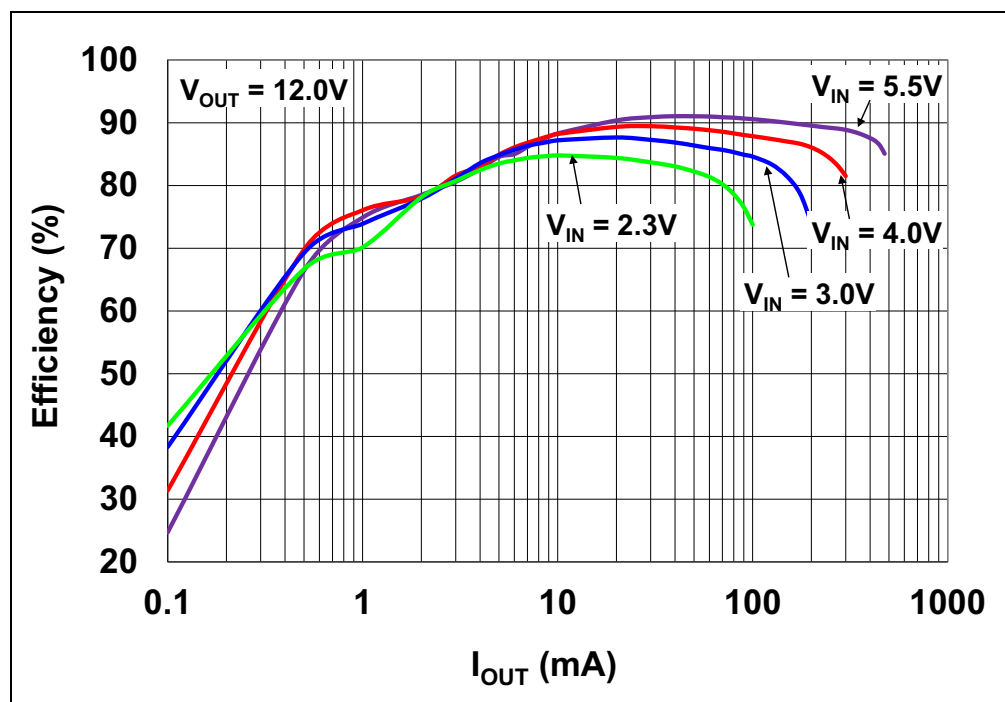

FIGURE 2-5: MCP1663 12V Output Efficiency vs. I_{OUT}

2.3.2 Test Results for MCP1663 - BOTTOM Circuit

The second circuit was developed for applications where an input voltage higher than the typical working range is needed. Refer to [Figure 2-7](#) for the maximum output current that can be obtained for different input voltages.

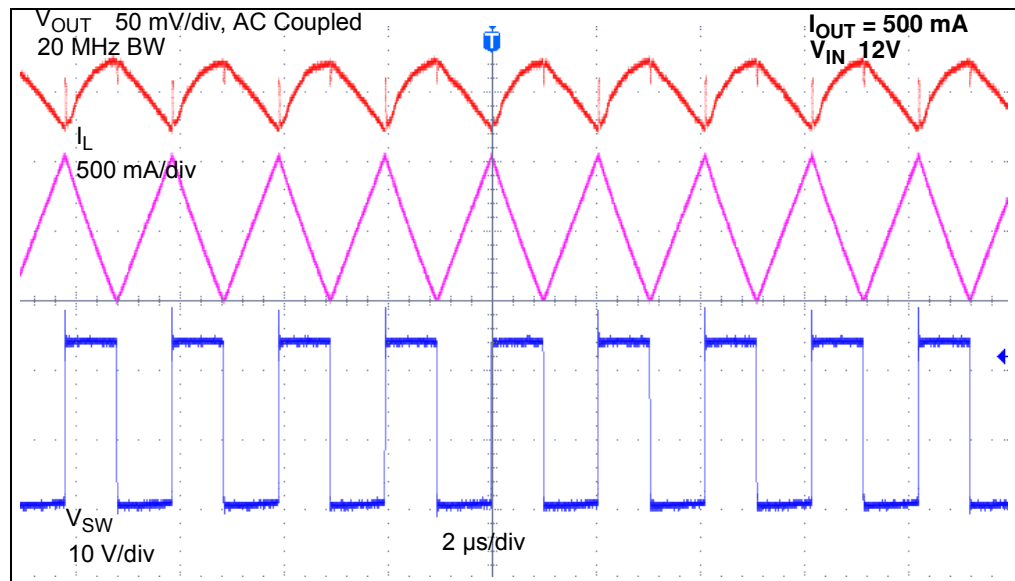

FIGURE 2-6: MCP1663 24.0V V_{OUT} High Load Operation Waveforms.

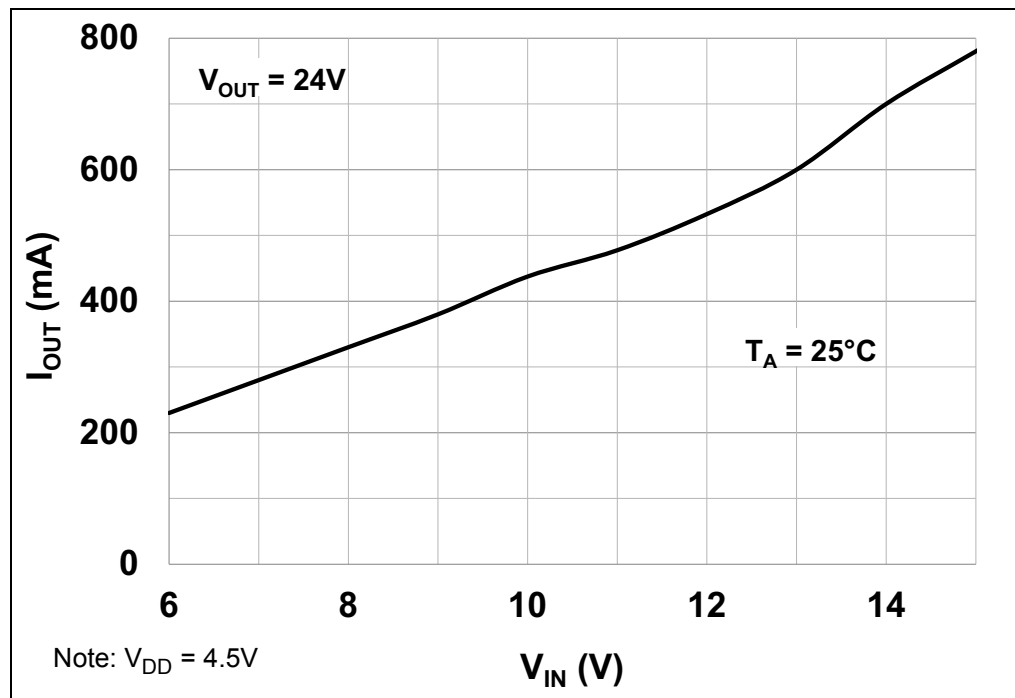

FIGURE 2-7: MCP1663 Maximum I_{OUT} vs. V_{IN} .

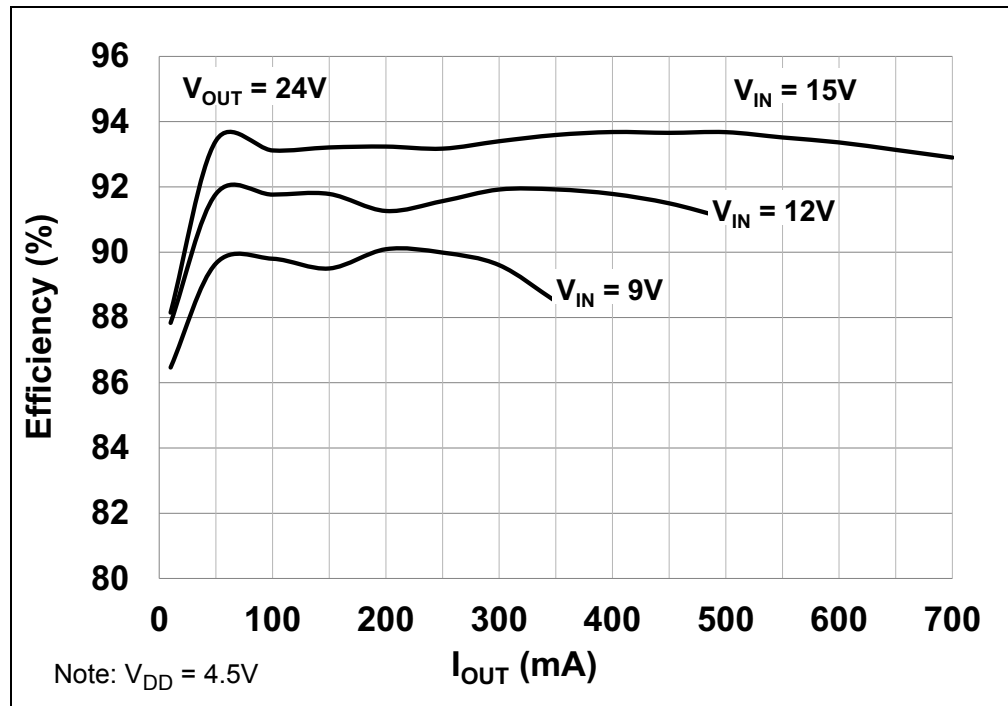

FIGURE 2-8: MCP1663 Efficiency vs. I_{OUT}.

2.4 BATTERY CONSIDERATIONS

When considering a power solution for a design, the battery needs to be carefully selected. Alkaline batteries are a commonly available option that delivers good performance in a variety of applications. Energizer® Ultimate Lithium batteries are an alternative power solution that provide superior-performance high drains and allows designers to utilize the full power range of the MCP1663 without sacrificing size or runtime.

Energizer Ultimate Lithium batteries utilize a primary cell chemistry that contain higher energy than alkaline batteries, and have much better high drain performance. Ultimate Lithium batteries produce a high, flat voltage profile that enables them to provide a high energy capacity even at high drains. Additionally, Ultimate Lithium batteries have a very low internal resistance, allowing them to maintain a high voltage at very high loads.



MCP1663 9V/12V/24V OUTPUT BOOST REGULATOR EVALUATION BOARD USER'S GUIDE

Appendix A. Schematic and Layouts

A.1 INTRODUCTION

This appendix contains the following schematics and layouts for the MCP1663 9V/12V/24V Output Boost Regulator Evaluation Board:

- Board – Schematic
- Board – Top Silk And Pads
- Board – Top Silk And Copper
- Board – Top Copper
- Board – Bottom Copper

A.2 BOARD – SCHEMATIC

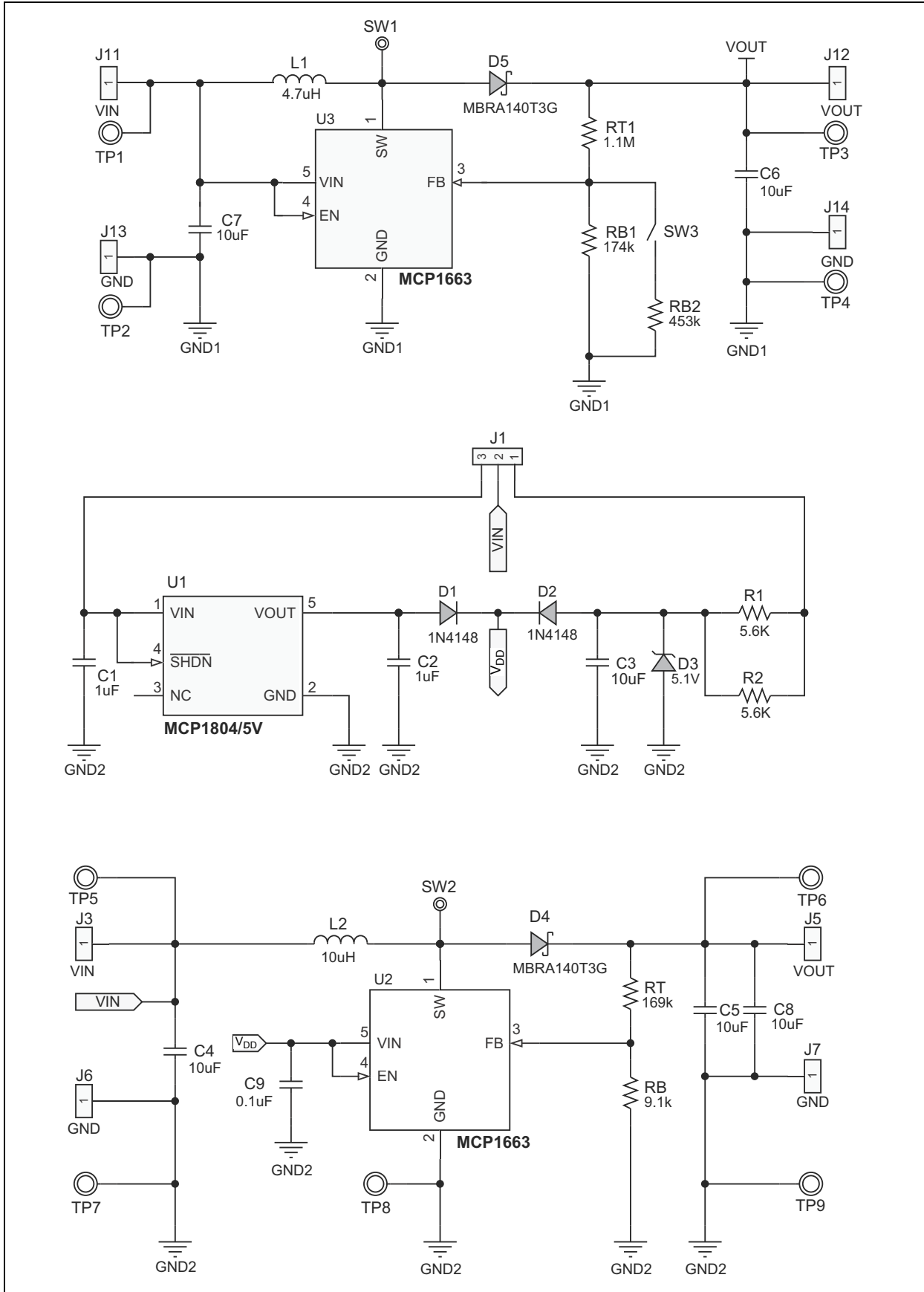

A.3 BOARD – TOP SILK AND PADS

