



Chipsmall Limited consists of a professional team with an average of over 10 year of expertise in the distribution of electronic components. Based in Hongkong, we have already established firm and mutual-benefit business relationships with customers from,Europe,America and south Asia,supplying obsolete and hard-to-find components to meet their specific needs.

With the principle of “Quality Parts,Customers Priority,Honest Operation,and Considerate Service”,our business mainly focus on the distribution of electronic components. Line cards we deal with include Microchip,ALPS,ROHM,Xilinx,Pulse,ON,Everlight and Freescale. Main products comprise IC,Modules,Potentiometer,IC Socket,Relay,Connector.Our parts cover such applications as commercial,industrial, and automotives areas.

We are looking forward to setting up business relationship with you and hope to provide you with the best service and solution. Let us make a better world for our industry!



## Contact us

Tel: +86-755-8981 8866 Fax: +86-755-8427 6832

Email & Skype: info@chipsmall.com Web: www.chipsmall.com

Address: A1208, Overseas Decoration Building, #122 Zhenhua RD., Futian, Shenzhen, China



## FEATURES

Isolated, RS-485/RS-422 transceiver, configurable as half- or full-duplex

±8 kV ESD protection on RS-485 input/output pins

16 Mbps data rate

Complies with ANSI TIA/EIA RS-485-A-1998 and ISO 8482: 1987(E)

Suitable for 5 V or 3.3 V operation ( $V_{DD1}$ )

High common-mode transient immunity: >25 kV/μs

Receiver has open-circuit, fail-safe design

32 nodes on the bus

Thermal shutdown protection

Safety and regulatory approvals

UL recognition: 5000 V rms isolation voltage for 1 minute, per UL 1577

VDE certificate of conformity

DIN V VDE V 0884-10 (VDE V 0884-10): 2006-12

Reinforced insulation,  $V_{IORM} = 849$  V peak

Operating temperature range: -40°C to +85°C

Wide body, 16-lead SOIC package

## APPLICATIONS

Isolated RS-485/RS-422 interfaces

Industrial field networks

INTERBUS

Multipoint data transmission systems

## GENERAL DESCRIPTION

The [ADM2491E](#) is an isolated data transceiver with ±8 kV ESD protection and is suitable for high speed, half- or full-duplex communication on multipoint transmission lines. For half-duplex operation, the transmitter outputs and the receiver inputs share the same transmission line. Transmitter output Pin Y is linked externally to receiver input Pin A, and transmitter output Pin Z is linked to receiver input Pin B.

The [ADM2491E](#) is designed for balanced transmission lines and complies with ANSI TIA/EIA RS-485-A-1998 and ISO 8482: 1987(E). The device employs Analog Devices, Inc., iCoupler® technology to combine a 3-channel isolator, a three-state differential line driver, and a differential input receiver into a single package.

## FUNCTIONAL BLOCK DIAGRAM

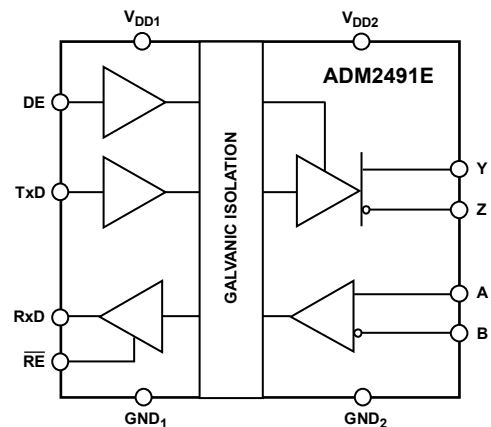

Figure 1.

06985-001

The differential transmitter outputs and receiver inputs feature electrostatic discharge circuitry that provides protection to ±8 kV using the human body model (HBM). The logic side of the device can be powered with either a 5 V or a 3.3 V supply, whereas the bus side requires an isolated 5 V supply.

The device has current-limiting and thermal shutdown features to protect against output short circuits and situations in which bus contention could cause excessive power dissipation.

The [ADM2491E](#) is available in a wide body, 16-lead SOIC package and operates over the -40°C to +85°C temperature range.

Rev. C

[Document Feedback](#)

Information furnished by Analog Devices is believed to be accurate and reliable. However, no responsibility is assumed by Analog Devices for its use, nor for any infringements of patents or other rights of third parties that may result from its use. Specifications subject to change without notice. No license is granted by implication or otherwise under any patent or patent rights of Analog Devices. Trademarks and registered trademarks are the property of their respective owners.

# ADM2491E\* PRODUCT PAGE QUICK LINKS

Last Content Update: 02/23/2017

---

## COMPARABLE PARTS

View a parametric search of comparable parts.

## EVALUATION KITS

- ADM2491E Evaluation Board

## DOCUMENTATION

### Application Notes

- AN-1176: Component Footprints and Symbols in the Binary .Bxl File Format
- AN-1179: Junction Temperature Calculation for Analog Devices RS-485/RS-422, CAN, and LVDS/M-LVDS Transceivers
- AN-960: RS-485/RS-422 Circuit Implementation Guide

### Data Sheet

- ADM2491E: High Speed, ESD-Protected, Half-/Full-Duplex iCoupler Isolated RS-485 Transceiver Data Sheet

### User Guides

- UG-302: Evaluation Board for the ADM2491E  $\pm 8$  kV Signal Isolated, High Speed (16 Mbps), ESD Protected, Full/Half Duplex RS-485 Transceiver

## REFERENCE MATERIALS

### Press

- Analog Devices Achieves Major Milestone by Shipping 1 Billionth Channel of iCoupler Digital Isolation

### Product Selection Guide

- Digital Isolator Product Selection and Resource Guide

### Solutions Bulletins & Brochures

- Emerging Energy Applications Solutions Bulletin, Volume 10, Issue 4
- Test & Instrumentation Solutions Bulletin, Volume 10, Issue 3

### Technical Articles

- Inside iCoupler® Technology:ADuM347x PWM Controller and Transformer Driver with Quad-Channel Isolators Design Summary
- NAppkin Note: Lowering the Power of the ADuM524x

## DESIGN RESOURCES

- ADM2491E Material Declaration
- PCN-PDN Information
- Quality And Reliability
- Symbols and Footprints

## DISCUSSIONS

View all ADM2491E EngineerZone Discussions.

## SAMPLE AND BUY

Visit the product page to see pricing options.

## TECHNICAL SUPPORT

Submit a technical question or find your regional support number.

## DOCUMENT FEEDBACK

Submit feedback for this data sheet.

---

## TABLE OF CONTENTS

Features .....	1	Switching Characteristics .....	9
Applications .....	1	Typical Performance Characteristics .....	10
Functional Block Diagram .....	1	Circuit Description.....	12
General Description .....	1	Electrical Isolation.....	12
Revision History .....	2	Truth Tables.....	12
Specifications.....	3	Thermal Shutdown .....	13
Timing Specifications .....	4	Fail-Safe Receiver Inputs .....	13
Package Characteristics .....	4	Magnetic Field Immunity.....	13
Regulatory Information.....	4	Applications Information .....	14
Insulation and Safety-Related Specifications.....	5	Isolated Power Supply Circuit .....	14
VDE 0884 Insulation Characteristics .....	5	PCB Layout .....	14
Absolute Maximum Ratings.....	6	Typical Applications.....	15
ESD Caution.....	6	Outline Dimensions .....	16
Pin Configuration and Functional Descriptions.....	7	Ordering Guide .....	16
Test Circuits.....	8		

## REVISION HISTORY

### 5/14—Rev. B to Rev. C

Changed $V_{IORM}$ from 848 V peak to 849 V peak (Throughout) .	1
Changes to VDE 0884 Insulation Characteristics Conditions ...	5
Changes to Ordering Guide .....	16

### 12/10—Rev. A to Rev. B

Changes to Figure 31 .....	15
----------------------------	----

### 12/08—Rev. 0 to Rev. A

Updated Regulatory Approval Status Throughout .....	1
Changes to Table 7.....	6

### 10/07—Revision 0: Initial Version



## SPECIFICATIONS

All voltages are relative to their respective ground;  $3.0\text{ V} \leq V_{DD1} \leq 5.5\text{ V}$ ,  $4.5\text{ V} \leq V_{DD2} \leq 5.5\text{ V}$ . All minimum/maximum specifications apply over the entire recommended operation range, unless otherwise noted. All typical specifications are at  $T_A = 25^\circ\text{C}$ ,  $V_{DD1} = V_{DD2} = 5.0\text{ V}$ , unless otherwise noted.

Table 1.

Parameter	Symbol	Min	Typ	Max	Unit	Test Conditions
<b>SUPPLY CURRENT</b>						
Power Supply Current, Logic Side						
TxD/RxD Data Rate = 2 Mbps	$I_{DD1}$			3.0	mA	Unloaded output
TxD/RxD Data Rate = 16 Mbps	$I_{DD1}$			6	mA	Half-duplex configuration, $R_{TERMINATION} = 120\ \Omega$ , see Figure 5
Power Supply Current, Bus Side						
TxD/RxD Data Rate = 2 Mbps	$I_{DD2}$			4.0	mA	Unloaded output
TxD/RxD Data Rate = 16 Mbps	$I_{DD2}$			50	mA	$V_{DD2} = 5.5\text{ V}$ , half-duplex configuration, $R_{TERMINATION} = 120\ \Omega$ , see Figure 5
<b>DRIVER</b>						
Differential Outputs						
Differential Output Voltage, Loaded	$ V_{OD} $	2.0		5.0	V	$R_L = 100\ \Omega$ (RS-422), see Figure 3
		1.5		5.0	V	$R_L = 54\ \Omega$ (RS-485), see Figure 3
		1.5		5.0	V	$-7\text{ V} \leq V_{TEST1} \leq 12\text{ V}$ , see Figure 4
$\Delta V_{OD} $ for Complementary Output States	$\Delta V_{OD} $			0.2	V	$R_L = 54\ \Omega$ or $100\ \Omega$ , see Figure 3
Common-Mode Output Voltage	$V_{OC}$			3.0	V	$R_L = 54\ \Omega$ or $100\ \Omega$ , see Figure 3
$\Delta V_{OC} $ for Complementary Output States	$\Delta V_{OC} $			0.2	V	$R_L = 54\ \Omega$ or $100\ \Omega$ , see Figure 3
Output Leakage Current (Y, Z)	$I_o$			100	$\mu\text{A}$	$DE = 0\text{ V}$ , $V_{DD2} = 0\text{ V}$ or $5\text{ V}$ , $V_{IN} = 12\text{ V}$
		-100			$\mu\text{A}$	$DE = 0\text{ V}$ , $V_{DD2} = 0\text{ V}$ or $5\text{ V}$ , $V_{IN} = -7\text{ V}$
Short-Circuit Output Current	$I_{OS}$			250	mA	
Logic Inputs DE, $\overline{RE}$ , TxD						
Input Threshold Low	$V_{IL}$	$0.25 \times V_{DD1}$			V	
Input Threshold High	$V_{IH}$			$0.7 \times V_{DD1}$	V	
Input Current	$I_{TXD}$	-10	+0.01	+10	$\mu\text{A}$	
<b>RECEIVER</b>						
Differential Inputs						
Differential Input Threshold Voltage	$V_{TH}$	-0.2		+0.2	V	
Input Voltage Hysteresis	$V_{HYS}$		30		mV	$V_{OC} = 0\text{ V}$
Input Current (A, B)	$I_i$			+1.0	mA	$V_{OC} = 12\text{ V}$
		-0.8			mA	$V_{OC} = -7\text{ V}$
Line Input Resistance	$R_{IN}$	12			k $\Omega$	
Logic Outputs						
Output Voltage Low	$V_{OLRXD}$		0.2	0.4	V	$I_{ORXD} = 1.5\text{ mA}$ , $V_A - V_B = -0.2\text{ V}$
Output Voltage High	$V_{OHRXD}$	$V_{DD1} - 0.3$	$V_{DD1} - 0.2$		V	$I_{ORXD} = -1.5\text{ mA}$ , $V_A - V_B = 0.2\text{ V}$
Short-Circuit Current				100	mA	
Three-State Output Leakage Current	$I_{OZR}$			$\pm 1$	$\mu\text{A}$	$V_{DD1} = 5.5\text{ V}$ , $0\text{ V} < V_{OUT} < V_{DD1}$
COMMON-MODE TRANSIENT IMMUNITY <sup>1</sup>		25			kV/ $\mu\text{s}$	$V_{CM} = 1\text{ kV}$ , transient magnitude = 800V

<sup>1</sup> CM is the maximum common-mode voltage slew rate that can be sustained while maintaining specification-compliant operation.  $V_{CM}$  is the common-mode potential difference between the logic and bus sides. The transient magnitude is the range over which the common mode is slewed. The common-mode voltage slew rates apply to both rising and falling common-mode voltage edges.

**TIMING SPECIFICATIONS**T<sub>A</sub> = -40°C to +85°C.

Table 2.

Parameter	Symbol	Min	Typ	Max	Unit	Test Conditions
<b>DRIVER</b>						
Maximum Data Rate		16			Mbps	
Propagation Delay	t <sub>PLH</sub> , t <sub>PHL</sub>		45	60	ns	R <sub>L</sub> = 54 Ω, C <sub>L1</sub> = C <sub>L2</sub> = 100 pF, see Figure 6 and Figure 10
Pulse Width Distortion, t <sub>PWD</sub> =  t <sub>PYLH</sub> - t <sub>PYHL</sub>  , t <sub>PWD</sub> =  t <sub>PZLH</sub> - t <sub>PZHL</sub>	t <sub>PWD</sub>			7	ns	R <sub>L</sub> = 54 Ω, C <sub>L1</sub> = C <sub>L2</sub> = 100 pF, see Figure 6 and Figure 10
Single-Ended Output Rise/Fall Times	t <sub>R</sub> , t <sub>F</sub>			20	ns	R <sub>L</sub> = 54 Ω, C <sub>L1</sub> = C <sub>L2</sub> = 100 pF, see Figure 6 and Figure 10
Enable Time				55	ns	R <sub>L</sub> = 110 Ω, C <sub>L</sub> = 50 pF, see Figure 8 and Figure 11
Disable Time				55	ns	R <sub>L</sub> = 110 Ω, C <sub>L</sub> = 50 pF, see Figure 8 and Figure 11
<b>RECEIVER</b>						
Propagation Delay	t <sub>PLH</sub> , t <sub>PHL</sub>			60	ns	C <sub>L</sub> = 15 pF, see Figure 7 and Figure 12
Pulse Width Distortion, t <sub>PWD</sub> =  t <sub>PLH</sub> - t <sub>PHL</sub>	t <sub>PWD</sub>			10	ns	C <sub>L</sub> = 15 pF, see Figure 7 and Figure 12
Enable Time				13	ns	R <sub>L</sub> = 1 kΩ, C <sub>L</sub> = 15 pF, see Figure 9 and Figure 13
Disable Time				13	ns	R <sub>L</sub> = 1 kΩ, C <sub>L</sub> = 15 pF, see Figure 9 and Figure 13

**PACKAGE CHARACTERISTICS**

Table 3.

Parameter	Symbol	Min	Typ	Max	Unit	Test Conditions
Resistance (Input to Output) <sup>1</sup>	R <sub>I-O</sub>		10 <sup>12</sup>		Ω	
Capacitance (Input to Output) <sup>1</sup>	C <sub>I-O</sub>		3		pF	f = 1 MHz
Input Capacitance <sup>2</sup>	C <sub>I</sub>		4		pF	
Input IC Junction-to-Case Thermal Resistance	θ <sub>JCI</sub>		33		°C/W	Thermocouple located at center of package underside
Output IC Junction-to-Case Thermal Resistance	θ <sub>JCO</sub>		28		°C/W	

<sup>1</sup> Device considered a 2-terminal device: Pin 1, Pin 2, Pin 3, Pin 4, Pin 5, Pin 6, Pin 7, and Pin 8 are shorted together, and Pin 9, Pin 10, Pin 11, Pin 12, Pin 13, Pin 14, Pin 15, and Pin 16 are shorted together.

<sup>2</sup> Input capacitance is from any input data pin to ground.

**REGULATORY INFORMATION**

Table 4.

UL <sup>1</sup>	VDE <sup>2</sup>
Recognized under the 1577 component recognition program <sup>1</sup> 5000 V rms isolation voltage	Certified according to DIN V VDE V 0884-10 (VDE V 0884-10): 2006-12 <sup>2</sup> Reinforced insulation, 849 V peak

<sup>1</sup> In accordance with UL 1577, each ADM2491E is proof tested by applying an insulation test voltage ≥ 6000 V rms for 1 second (current leakage detection limit = 10 μA).

<sup>2</sup> In accordance with DIN V VDE V 0884-10, each ADM2491E is proof tested by applying an insulation test voltage ≥ 1590 V peak for 1 second (partial discharge detection limit = 5 pC).

**INSULATION AND SAFETY-RELATED SPECIFICATIONS**

Table 5.

Parameter	Symbol	Value	Unit	Conditions
Rated Dielectric Insulation Voltage		5000	V rms	1 minute duration
Minimum External Air Gap (Clearance)	L(I01)	7.7	mm min	Measured from input terminals to output terminals, shortest distance through air
Minimum External Tracking (Creepage)	L(I02)	8.1	mm min	Measured from input terminals to output terminals, shortest distance along body
Minimum Internal Gap (Internal Clearance)		0.017	mm min	Insulation distance through insulation
Tracking Resistance (Comparative Tracking Index)	CTI	>175	V	DIN IEC 112/VDE 0303 Part 1
Isolation Group		IIla		Material Group (DIN VDE 0110, 1/89)

**VDE 0884 INSULATION CHARACTERISTICS**

This isolator is suitable for reinforced electrical isolation only within the safety limit data. Maintenance of the safety data must be ensured by means of protective circuits.

An asterisk (\*) on a package denotes VDE 0884 approval for 849 V peak working voltage.

Table 6.

Description	Symbol	Characteristic	Unit
Installation Classification per DIN VDE 0110 for Rated Mains Voltage		I to IV	
≤300 V rms		I to II	
≤450 V rms		I to II	
≤600 V rms		40/105/21	
Climatic Classification		2	
Pollution Degree (DIN VDE 0110, see Table 1)		849	V peak
Maximum Working Insulation Voltage	$V_{IORM}$	1590	V peak
Input-to-Output Test Voltage, Method b1	$V_{PR}$		
$V_{IORM} \times 1.875 = V_{PR}$ , 100% Production Tested, $t_m = 1$ sec, Partial Discharge < 5 pC			
Input-to-Output Test Voltage, Method a	$V_{PR}$		
After Environmental Tests, Subgroup 1		1357	V peak
$V_{IORM} \times 1.6 = V_{PR}$ , $t_m = 60$ sec, Partial Discharge < 5 pC			
After Input and/or Safety Test, Subgroup 2/Subgroup 3		1018	V peak
$V_{IORM} \times 1.2 = V_{PR}$ , $t_m = 60$ sec, Partial Discharge < 5 pC			
Highest Allowable Overvoltage (Transient Overvoltage, $t_{TR} = 10$ sec)	$V_{TR}$	6000	V peak
Safety-Limiting Values (Maximum Value Allowed in the Event of a Failure, see Figure 20)			
Case Temperature	$T_S$	150	°C
Input Current	$I_{S, INPUT}$	265	mA
Output Current	$I_{S, OUTPUT}$	335	mA
Insulation Resistance at $T_S$ , $V_{IO} = 500$ V	$R_S$	>10 <sup>9</sup>	Ω

## ABSOLUTE MAXIMUM RATINGS

$T_A = 25\text{ }^\circ\text{C}$ , unless otherwise noted. Each voltage is relative to its respective ground.

Table 7.

Parameter	Rating
Storage Temperature	$-55^\circ\text{C}$ to $+150^\circ\text{C}$
Ambient Operating Temperature	$-40^\circ\text{C}$ to $+85^\circ\text{C}$
$V_{DD1}$	$-0.5\text{ V}$ to $+7\text{ V}$
$V_{DD2}$	$-0.5\text{ V}$ to $+6\text{ V}$
Logic Input Voltages	$-0.5\text{ V}$ to $V_{DD1} + 0.5\text{ V}$
Bus Terminal Voltages	$-9\text{ V}$ to $+14\text{ V}$
Logic Output Voltages	$-0.5\text{ V}$ to $V_{DD1} + 0.5\text{ V}$
Average Output Current, per Pin	$\pm 35\text{ mA}$
ESD (Human Body Model) on A, B, Y, and Z Pins	$\pm 8\text{ kV}$
$\theta_{JA}$ Thermal Impedance	$60^\circ\text{C/W}$

Stresses above those listed under Absolute Maximum Ratings may cause permanent damage to the device. This is a stress rating only; functional operation of the device at these or any other conditions above those indicated in the operational section of this specification is not implied. Exposure to absolute maximum rating conditions for extended periods may affect device reliability.

Absolute maximum ratings apply individually only, not in combination.

### ESD CAUTION



**ESD (electrostatic discharge) sensitive device.** Charged devices and circuit boards can discharge without detection. Although this product features patented or proprietary protection circuitry, damage may occur on devices subjected to high energy ESD. Therefore, proper ESD precautions should be taken to avoid performance degradation or loss of functionality.



## PIN CONFIGURATION AND FUNCTIONAL DESCRIPTIONS

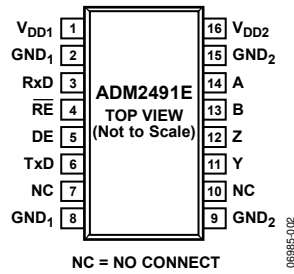

Figure 2. ADM2491E Pin Configuration

Table 8. Pin Function Descriptions

Pin No.	Mnemonic	Description
1	V <sub>DD1</sub>	Power Supply (Logic Side). Decoupling capacitor to GND <sub>1</sub> required; capacitor value should be between 0.01 $\mu$ F and 0.1 $\mu$ F.
2, 8	GND <sub>1</sub>	Ground (Logic Side).
3	RxD	Receiver Output.
4	RE	Receiver Enable Input. Active low logic input. When this pin is low, the receiver is enabled; when high, the receiver is disabled.
5	DE	Driver Enable Input. Active high logic input. When this pin is high, the driver (transmitter) is enabled; when low, the driver is disabled.
6	TxD	Transmit Data.
7, 10	NC	No Connect. This pin must be left floating.
9, 15	GND <sub>2</sub>	Ground (Bus Side).
11	Y	Driver Noninverting Output.
12	Z	Driver Inverting Output.
13	B	Receiver Inverting Input.
14	A	Receiver Noninverting Input.
16	V <sub>DD2</sub>	Power Supply (Bus Side). Decoupling capacitor to GND <sub>2</sub> is required; capacitor value should be between 0.01 $\mu$ F and 0.1 $\mu$ F.

TEST CIRCUITS

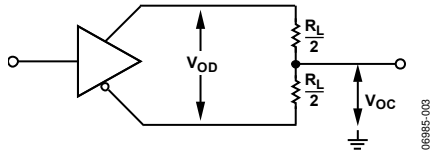

Figure 3. Driver Voltage Measurement

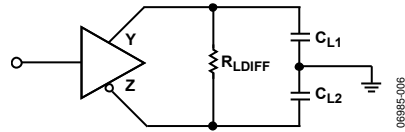

Figure 6. Driver Propagation Delay

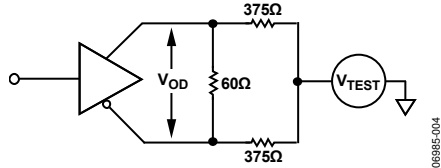

Figure 4. Driver Voltage Measurement

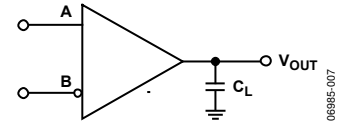

Figure 7. Receiver Propagation Delay

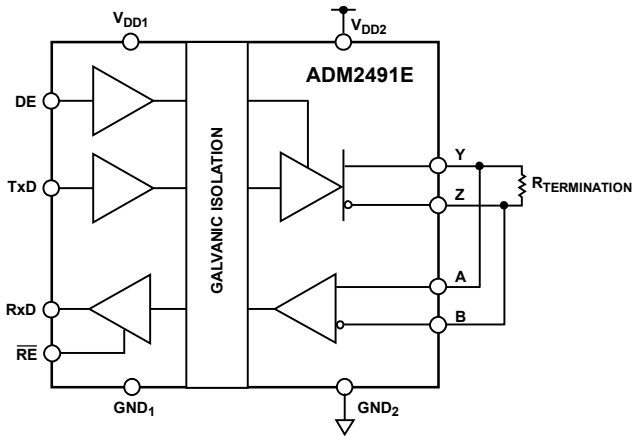

Figure 5. Supply Current Measurement Test Circuit

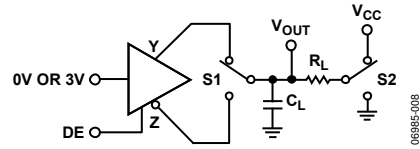

Figure 8. Driver Enable/Disable

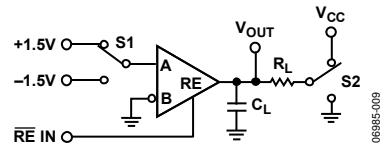

Figure 9. Receiver Enable/Disable

### SWITCHING CHARACTERISTICS

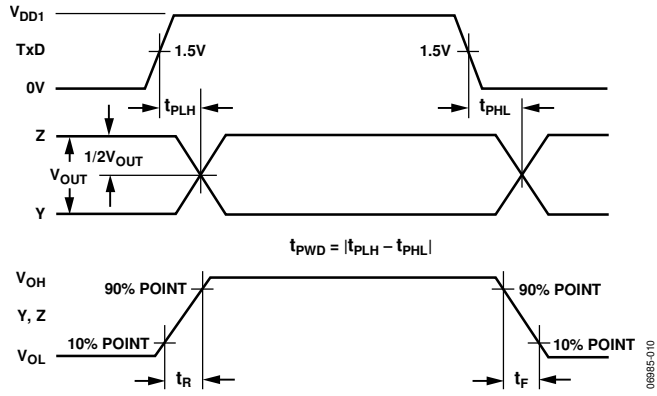

Figure 10. Driver Propagation Delay, Rise/Fall Timing

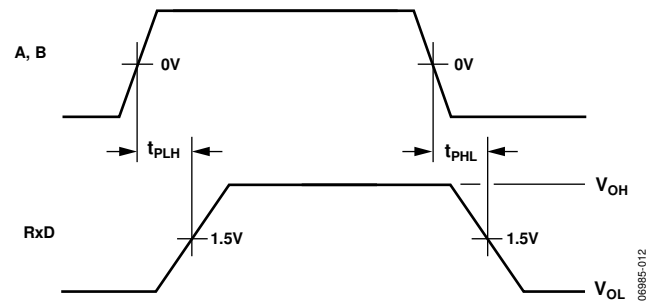

Figure 12. Receiver Propagation Delay

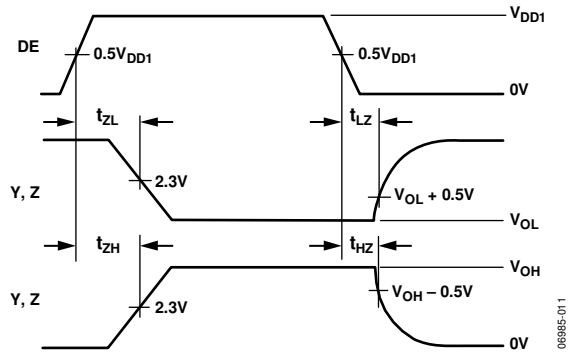

Figure 11. Driver Enable/Disable Delay

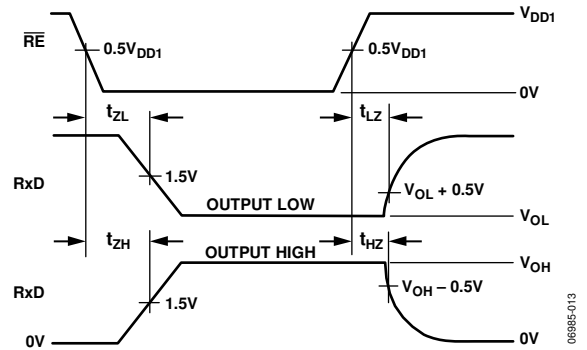

Figure 13. Receiver Enable/Disable Delay

TYPICAL PERFORMANCE CHARACTERISTICS

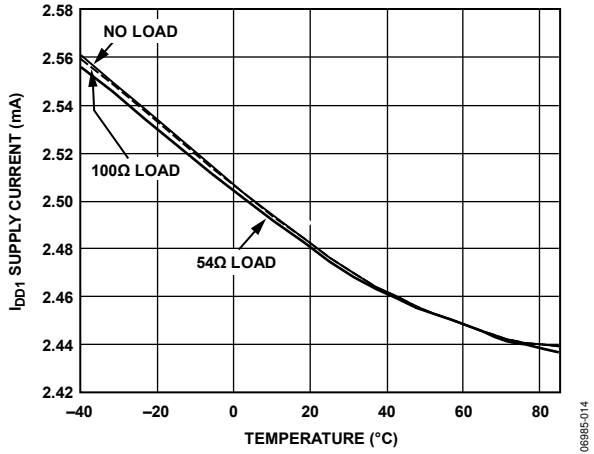

Figure 14.  $I_{DD1}$  Supply Current vs. Temperature

06985-014

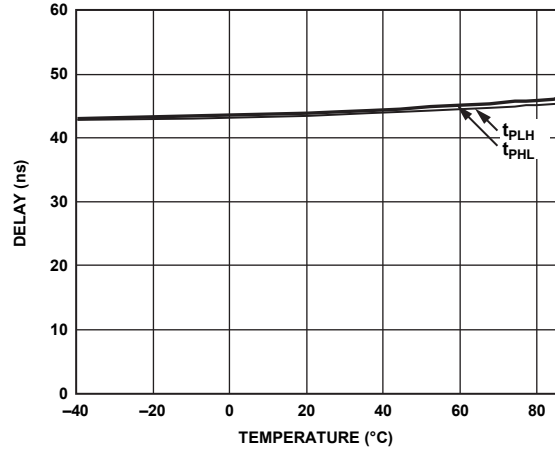

Figure 17. Receiver Propagation Delay vs. Temperature

06985-035

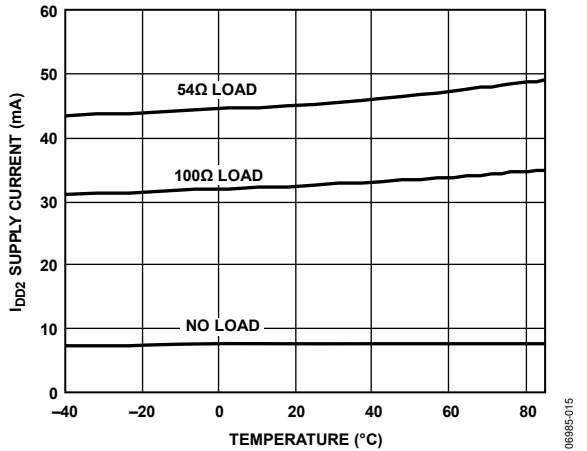

Figure 15.  $I_{DD2}$  Supply Current vs. Temperature

06985-015

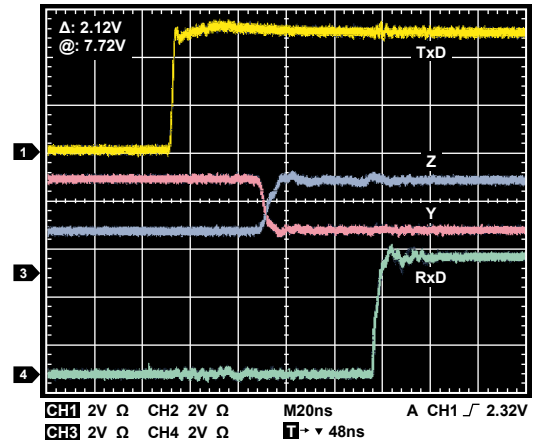

Figure 18. Driver/Receiver Propagation Delay, Low to High ( $R_{LDIFF} = 54\Omega, C_{L1} = C_{L2} = 100\text{ pF}$ )

06985-002

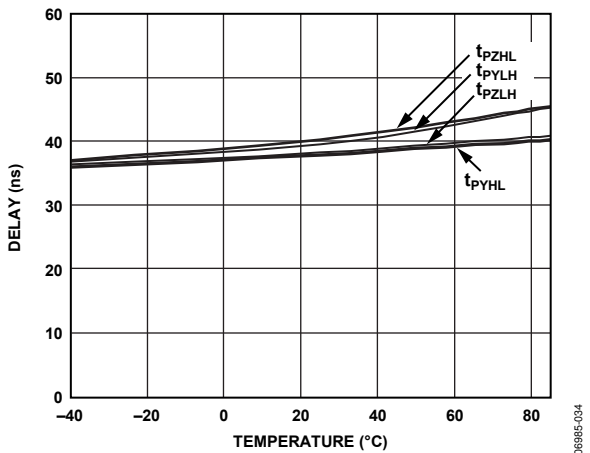

Figure 16. Driver Propagation Delay vs. Temperature

06985-004

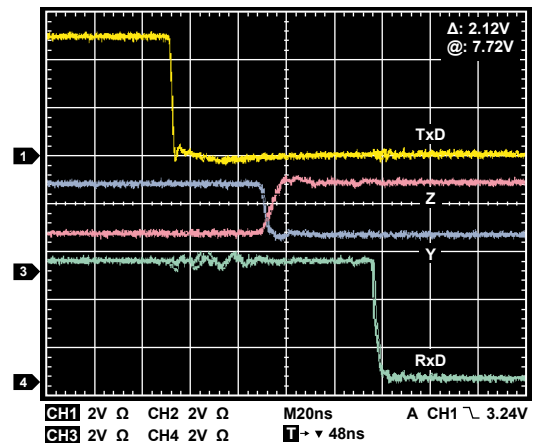

Figure 19. Driver/Receiver Propagation Delay, High to Low ( $R_{LDIFF} = 54\Omega, C_{L1} = C_{L2} = 100\text{ pF}$ )

06985-003

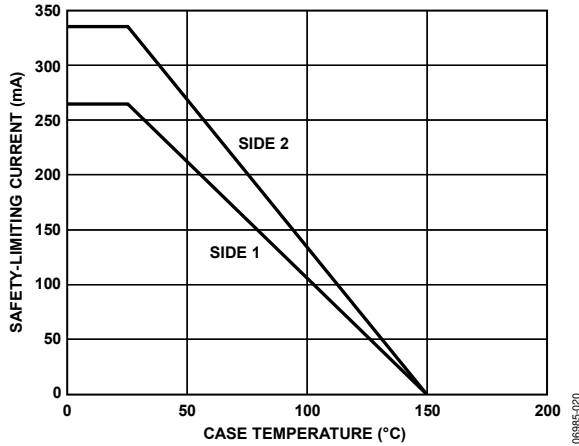

Figure 20. Thermal Derating Curve, Dependence of Safety-Limiting Values with Case Temperature per VDE 0884

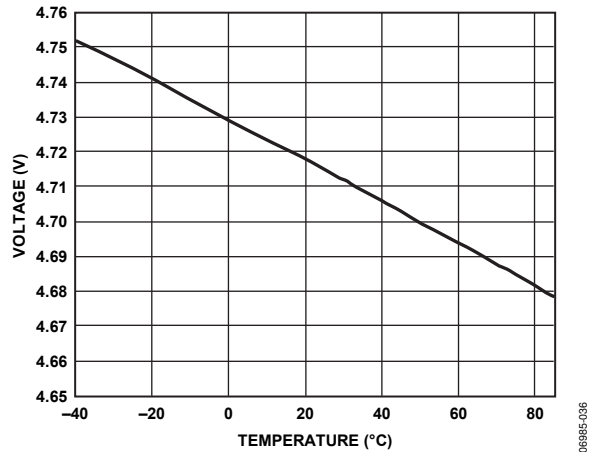

Figure 23. Receiver Output High Voltage vs. Temperature,  $I_{RxD} = -4$  mA

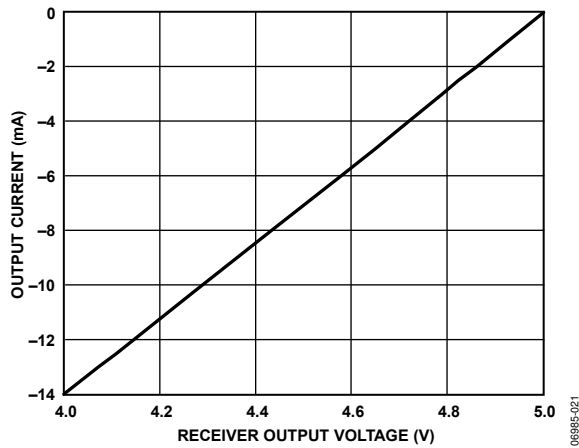

Figure 21. Output Current vs. Receiver Output High Voltage

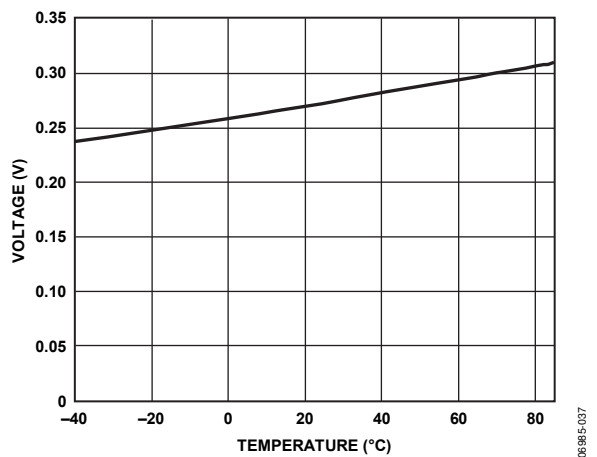

Figure 24. Receiver Output Low Voltage vs. Temperature,  $I_{RxD} = -4$  mA

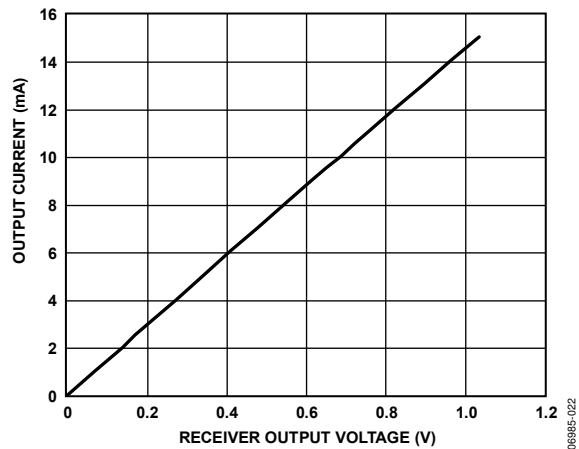

Figure 22. Output Current vs. Receiver Output Low Voltage

# CIRCUIT DESCRIPTION

## ELECTRICAL ISOLATION

In the ADM2491E, electrical isolation is implemented on the logic side of the interface. Therefore, the part has two main sections: a digital isolation section and a transceiver section (see Figure 25). The driver input signal, which is applied to the TxD pin and referenced to logic ground (GND<sub>1</sub>), is coupled across an isolation barrier to appear at the transceiver section referenced to isolated ground (GND<sub>2</sub>). Similarly, the receiver input, which is referenced to isolated ground in the transceiver section, is coupled across the isolation barrier to appear at the RxD pin referenced to logic ground.

### iCoupler Technology

The digital signals are transmitted across the isolation barrier using iCoupler technology. This technique uses chip scale transformer windings to couple the digital signals magnetically from one side of the barrier to the other. Digital inputs are encoded into waveforms that are capable of exciting the primary transformer winding. At the secondary winding, the induced waveforms are decoded into the binary value that was originally transmitted.

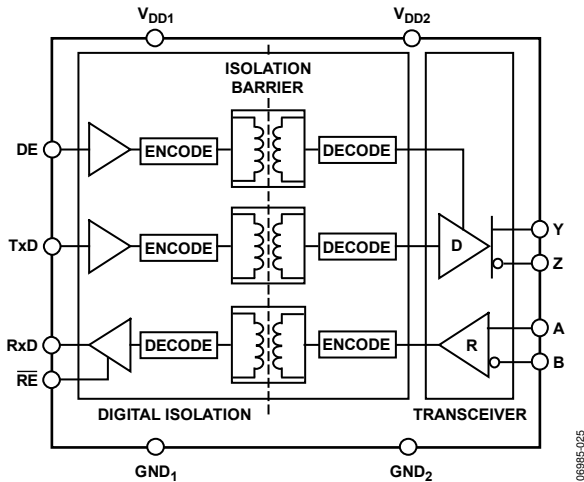

Figure 25. ADM2491E Digital Isolation and Transceiver Sections

## TRUTH TABLES

The truth tables in this section use the abbreviations shown in Table 9.

Table 9. Truth Table Abbreviations

Letter	Description
H	High level
L	Low level
I	Indeterminate
X	Irrelevant
Z	High impedance (off)
NC	Disconnected

Table 10. Transmitting

Supply Status		Inputs		Outputs	
V <sub>DD1</sub>	V <sub>DD2</sub>	DE	TxD	Y	Z
On	On	H	H	H	L
On	On	H	L	L	H
On	On	L	X	Z	Z
On	Off	X	X	Z	Z
Off	On	L	L	Z	Z
Off	Off	X	X	Z	Z

Table 11. Receiving

Supply Status		Inputs		Output
V <sub>DD1</sub>	V <sub>DD2</sub>	A - B (V)	RE	RxD
On	On	>0.2	L or NC	H
On	On	<-0.2	L or NC	L
On	On	-0.2 < A - B < +0.2	L or NC	I
On	On	Inputs open	L or NC	H
On	On	X	H	Z
On	Off	X	L or NC	H
Off	Off	X	L or NC	L



**THERMAL SHUTDOWN**

The ADM2491E contains thermal shutdown circuitry that protects the part from excessive power dissipation during fault conditions. Shorting the driver outputs to a low impedance source can result in high driver currents. The thermal sensing circuitry detects the increase in die temperature under this condition and disables the driver outputs. This circuitry is designed to disable the driver outputs when a die temperature of 150°C is reached. As the device cools, the drivers are re-enabled at a temperature of 140°C.

**FAIL-SAFE RECEIVER INPUTS**

The receiver inputs include a fail-safe feature that guarantees a logic high on the RxD pin when the A and B inputs are floating or open circuited.

**MAGNETIC FIELD IMMUNITY**

Because iCoupler devices use a coreless technology, no magnetic components are present and the problem of magnetic saturation of the core material does not exist. Therefore, iCoupler devices have essentially infinite dc field immunity. The following analysis defines the conditions under which this may occur. The 3 V operating condition of the ADM2491E is examined because it represents the most susceptible mode of operation.

The limitation on the ac magnetic field immunity of the iCoupler is set by the condition that induced an error voltage in the receiving coil (the bottom coil in this case) that was large to either falsely set or reset the decoder. The voltage induced across the bottom coil is given by

$$V = -\left(\frac{d\beta}{dt}\right) \sum \pi r_n^2 ; n = 1, 2, \dots, N$$

where (if the pulses at the transformer output are greater than 1.0 V in amplitude):

$\beta$  is the magnetic flux density (gauss).

$N$  is the number of turns in the receiving coil.

$r_n$  is the radius of the  $n^{\text{th}}$  turn in the receiving coil (cm).

The decoder has a sensing threshold of about 0.5 V; therefore, there is a 0.5 V margin in which induced voltages can be tolerated.

Given the geometry of the receiving coil and an imposed requirement that the induced voltage is, at most, 50% of the 0.5 V margin at the decoder, a maximum allowable magnetic field is calculated, as shown in Figure 26.

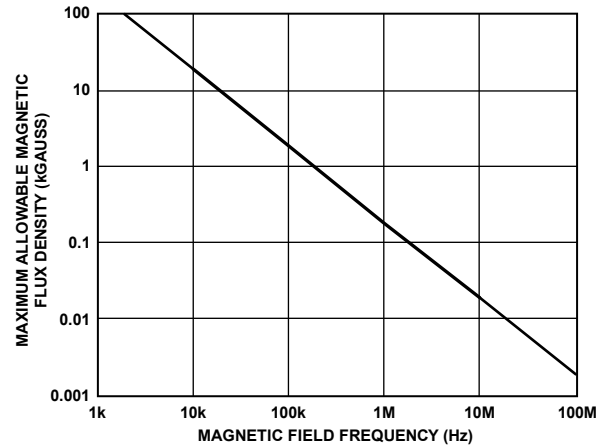

Figure 26. Maximum Allowable External Magnetic Flux Density

For example, at a magnetic field frequency of 1 MHz, the maximum allowable magnetic field of 0.2 kgauss induces a voltage of 0.25 V at the receiving coil. This is about 50% of the sensing threshold and does not cause a faulty output transition. Similarly, if such an event occurs during a transmitted pulse and is the worst-case polarity, it reduces the received pulse from >1.0 V to 0.75 V—still well above the 0.5 V sensing threshold of the decoder.

Figure 27 shows the magnetic flux density values in terms of more familiar quantities, such as maximum allowable current flow, at given distances away from the ADM2491E transformers.

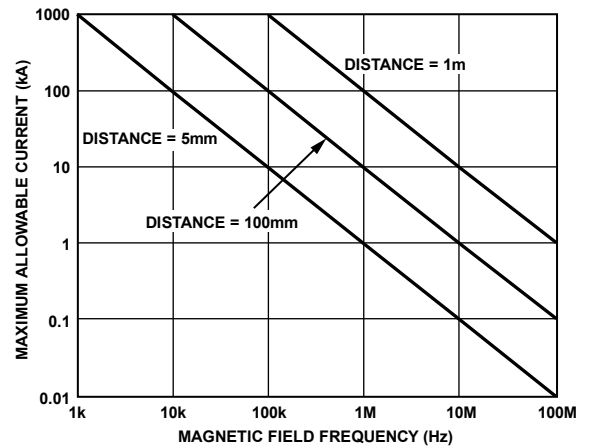

Figure 27. Maximum Allowable Current for Various Current-to-ADM2491E Spacings

With combinations of strong magnetic field and high frequency, any loops formed by printed circuit board traces can induce error voltages large enough to trigger the thresholds of succeeding circuitry. Care should be taken in the layout of such traces to avoid this possibility.

## APPLICATIONS INFORMATION

### ISOLATED POWER SUPPLY CIRCUIT

The ADM2491E requires isolated power capable of 5 V at up to approximately 75 mA (this current is dependent on the data rate and termination resistors used) to be supplied between the V<sub>DD2</sub> and the GND<sub>2</sub> pins. A transformer driver circuit with a center-tapped transformer and LDO can be used to generate the isolated 5 V supply, as shown in Figure 28. The center-tapped transformer provides electrical isolation of the 5 V power supply. The primary winding of the transformer is excited with a pair of square waveforms that are 180° out of phase with each other. A pair of Schottky diodes and a smoothing capacitor are used to create a rectified signal from the secondary winding. The ADP3330 linear voltage regulator provides a regulated power supply to the bus-side circuitry (V<sub>DD2</sub>) of the ADM2491E.

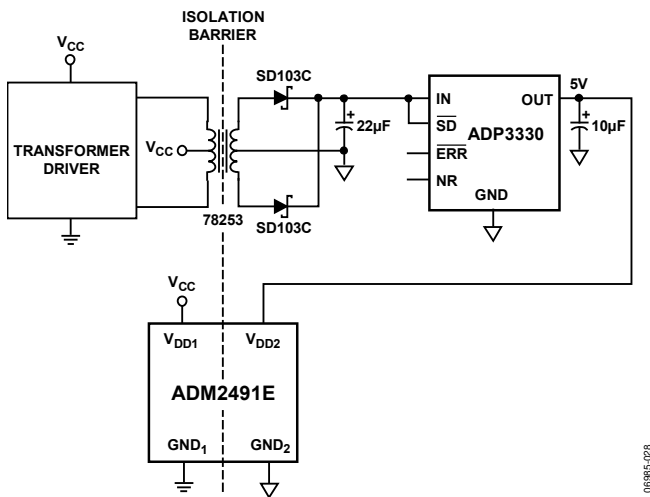

Figure 28. Isolated Power Supply Circuit

### PCB LAYOUT

The ADM2491E isolated RS-485 transceiver requires no external interface circuitry for the logic interfaces. Power supply bypassing is required at the input and output supply pins (see Figure 29). Bypass capacitors are conveniently connected between Pin 1 and Pin 2 for V<sub>DD1</sub> and between Pin 15 and Pin 16 for V<sub>DD2</sub>. The capacitor value should be between 0.01 µF and 0.1 µF. The total lead length between both ends of the capacitor and the input power supply pin should not exceed 20 mm. Bypassing between Pin 1 and Pin 8 and between Pin 9 and Pin 16 should also be considered unless the ground pair on each package side is connected close to the package.

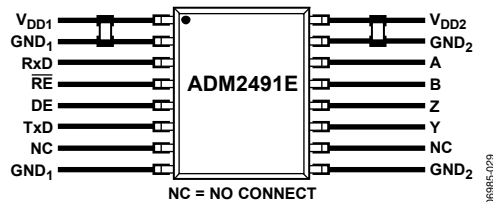

Figure 29. Recommended Printed Circuit Board Layout

In applications involving high common-mode transients, care should be taken to ensure that board coupling across the isolation barrier is minimized. Furthermore, the board layout should be designed such that any coupling that does occur equally affects all pins on a given component side. Failure to ensure this could cause voltage differentials between pins exceeding the absolute maximum ratings of the device, thereby leading to latch-up or permanent damage.

**TYPICAL APPLICATIONS**

Figure 30 and Figure 31 show typical applications of the ADM2491E in half-duplex and full-duplex RS-485 network configurations. Up to 32 transceivers can be connected to the RS-485 bus. To minimize reflections, the line must be terminated

at the receiving end in its characteristic impedance, and stub lengths off the main line must be kept as short as possible. For half-duplex operation, this means that both ends of the line must be terminated because either end can be the receiving end.

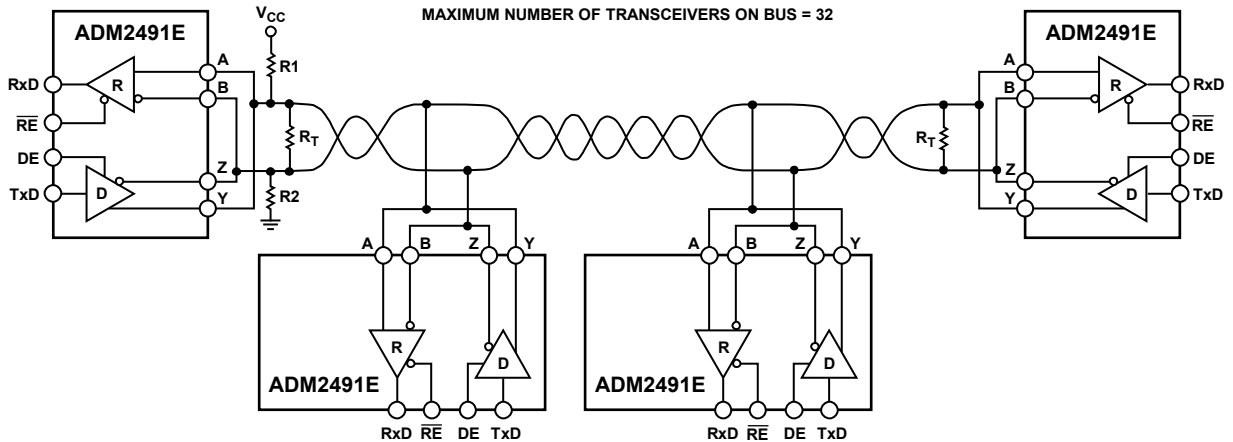

- NOTES  
 1.  $R_T$  IS EQUAL TO THE CHARACTERISTIC IMPEDANCE OF THE CABLE.  
 2. ISOLATION NOT SHOWN.

Figure 30. ADM2491E Typical Half-Duplex RS-485 Network

06986-030

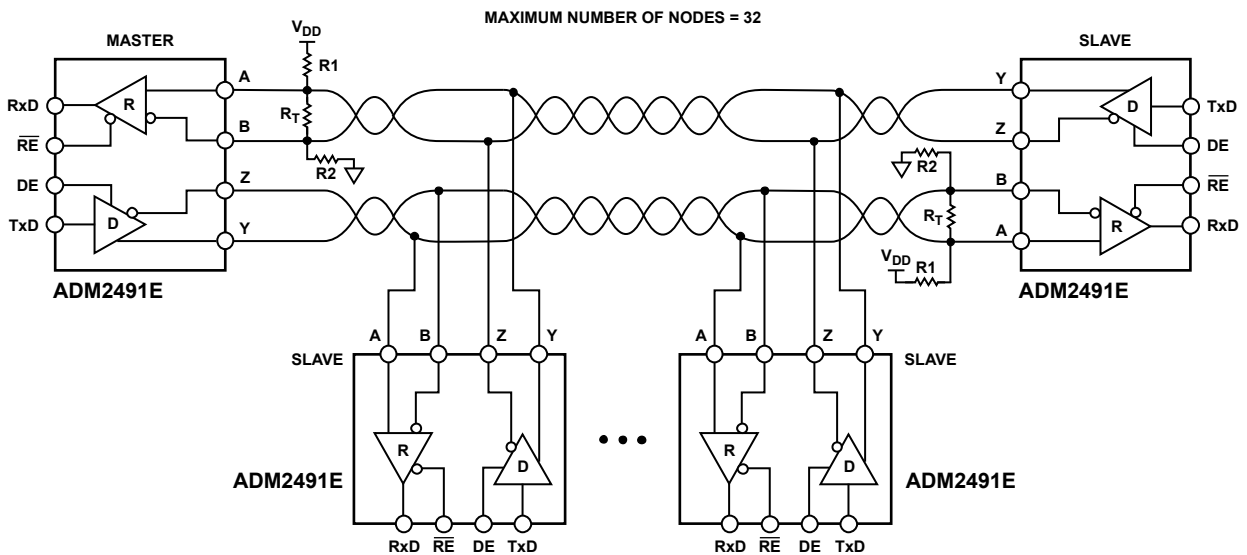

- NOTES  
 1.  $R_T$  IS EQUAL TO THE CHARACTERISTIC IMPEDANCE OF THE CABLE.

Figure 31. ADM2491E Typical Full-Duplex RS-485 Network

06985-031

OUTLINE DIMENSIONS

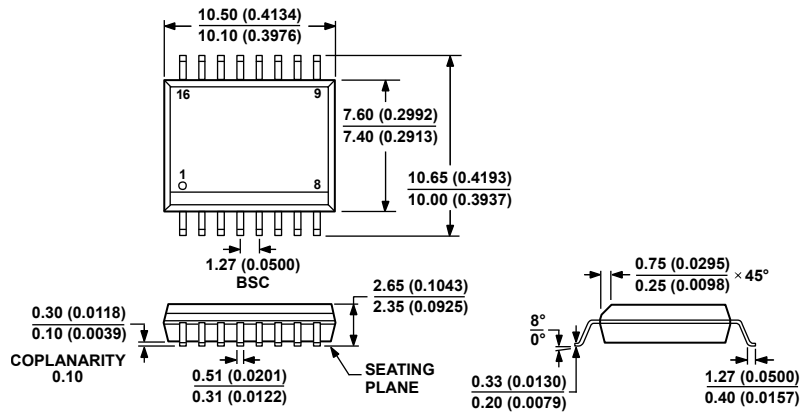

COMPLIANT TO JEDEC STANDARDS MS-013-AA  
 CONTROLLING DIMENSIONS ARE IN MILLIMETERS; INCH DIMENSIONS  
 (IN PARENTHESES) ARE ROUNDED-OFF MILLIMETER EQUIVALENTS FOR  
 REFERENCE ONLY AND ARE NOT APPROPRIATE FOR USE IN DESIGN.

Figure 32. 16-Lead Standard Small Outline Package [SOIC\_W]  
 Wide Body  
 (RW-16)

Dimensions shown in millimeters and (inches)

03-27-2007-B

ORDERING GUIDE

Model <sup>1</sup>	Temperature Range	Package Description	Package Option
ADM2491EBRWZ	-40°C to +85°C	16-Lead Standard Small Outline Package, Wide Body [SOIC_W]	RW-16
ADM2491EBRWZ-REEL7	-40°C to +85°C	16-Lead Standard Small Outline Package, Wide Body [SOIC_W]	RW-16
EVAL-ADM2491EEBZ		Evaluation Board	

<sup>1</sup> Z = RoHS Compliant Part.