



Chipsmall Limited consists of a professional team with an average of over 10 year of expertise in the distribution of electronic components. Based in Hongkong, we have already established firm and mutual-benefit business relationships with customers from,Europe,America and south Asia,supplying obsolete and hard-to-find components to meet their specific needs.

With the principle of “Quality Parts,Customers Priority,Honest Operation,and Considerate Service”,our business mainly focus on the distribution of electronic components. Line cards we deal with include Microchip,ALPS,ROHM,Xilinx,Pulse,ON,Everlight and Freescale. Main products comprise IC,Modules,Potentiometer,IC Socket,Relay,Connector.Our parts cover such applications as commercial,industrial, and automotives areas.

We are looking forward to setting up business relationship with you and hope to provide you with the best service and solution. Let us make a better world for our industry!



Contact us

Tel: +86-755-8981 8866 Fax: +86-755-8427 6832

Email & Skype: info@chipsmall.com Web: www.chipsmall.com

Address: A1208, Overseas Decoration Building, #122 Zhenhua RD., Futian, Shenzhen, China



FEATURES

- 460 kbps data rate
- 1 Tx and 1 Rx
- Meets EIA/TIA-232E specifications
- 0.1 μF charge pump capacitors
- Contact discharge: ±8 kV
- Air gap discharge: ±15 kV

APPLICATIONS

- General-purpose RS-232 data links
- Industrial/telecommunications diagnostics ports

GENERAL DESCRIPTION

The [ADM3101E](#) is a high speed, single-channel, RS-232/ITU-T V.28 transceiver interface device that operates from a single 3.3 V power supply. Low power consumption makes it ideal for battery-powered portable instruments.

The [ADM3101E](#) conforms to the EIA/TIA-232E and ITU-T V.28 specifications and operates at data rates of up to 460 kbps.

All RS-232 (T_{OUT} and R_{IN}) and CMOS (T_{IN} and R_{OUT}) inputs and outputs are protected against electrostatic discharges (up to ±15 kV ESD protection).

FUNCTIONAL BLOCK DIAGRAM

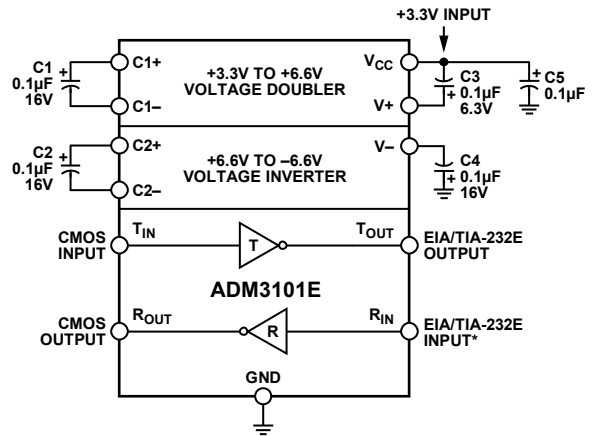

*INTERNAL 5kΩ PULL-DOWN RESISTOR ON THE RS-232 INPUT.

Figure 1.

Because of the ±15 kV ESD protection of the [ADM3101E](#) input/output pins, this device is ideally suited for operation in electrically harsh environments or where RS-232 cables are frequently plugged and unplugged.

Four external 0.1 μF charge pump capacitors are used for the voltage doubler/inverter permitting operation from a single 3.3 V supply.

The [ADM3101E](#) is available in both a 12-lead LFCSP and 16-lead QSOP, specified over the -40°C to +85°C temperature range.

ADM3101E* PRODUCT PAGE QUICK LINKS

Last Content Update: 02/23/2017

COMPARABLE PARTS

View a parametric search of comparable parts.

DOCUMENTATION

Data Sheet

- ADM3101E: 15 kV ESD Protected, 3.3 V Single-Channel RS-232 Line Driver/Receiver Data Sheet

SOFTWARE AND SYSTEMS REQUIREMENTS

- ADI RS-485/RS-422 Cross Reference Guide
- RS-232 Transceivers Cross Reference Guide

REFERENCE MATERIALS

Solutions Bulletins & Brochures

- RS-232 Transceivers Applications Bulletin (Summer 2008)

DESIGN RESOURCES

- ADM3101E Material Declaration
- PCN-PDN Information
- Quality And Reliability
- Symbols and Footprints

DISCUSSIONS

View all ADM3101E EngineerZone Discussions.

SAMPLE AND BUY

Visit the product page to see pricing options.

TECHNICAL SUPPORT

Submit a technical question or find your regional support number.

DOCUMENT FEEDBACK

Submit feedback for this data sheet.

TABLE OF CONTENTS

| | | | |
|--------------------------------|---|--|---|
| Features | 1 | Pin Configurations and Function Descriptions | 5 |
| Applications | 1 | Typical Performance Characteristics | 6 |
| Functional Block Diagram | 1 | Theory of Operation | 8 |
| General Description | 1 | Circuit Description | 8 |
| Revision History | 2 | High Baud Rate | 8 |
| Specifications | 3 | Outline Dimensions | 9 |
| Absolute Maximum Ratings | 4 | Ordering Guide | 9 |
| ESD Caution | 4 | | |

REVISION HISTORY

5/15—Rev. C to Rev. D

| | |
|---|---|
| Change to θ_{JA} , Thermal Impedance (LFCSP) Parameter, Table 2 | 4 |
| Changes to Figure 2 and Table 3 | 5 |
| Changes to Ordering Guide | 9 |
| Updated Outline Dimensions | 9 |

7/08—Rev. B to Rev. C

| | |
|--|---|
| Changes to General Description Section | 1 |
| Reformatted Table 1 | 4 |
| Change to T_{IN} Rating, Table 2 | 4 |
| Changes to Figure 2 | 5 |
| Moved High Baud Rate Section | 8 |
| Added Exposed Pad Notation to Outline Dimensions | 9 |

12/07—Rev. A to Rev. B

| | |
|--|----|
| Added 16-Lead QSOP Package (Universal) | 1 |
| Updated Outline Dimensions | 10 |
| Changes to Ordering Guide | 10 |

10/07—Rev. 0 to Rev. A

| | |
|---|---|
| Changes to Figure 1 | 1 |
| Changes to Table 1, RS-232 Receiver Section | 3 |
| Changes to Table 3 | 5 |
| Changes to Figure 11 | 8 |

5/07—Revision 0: Initial Version

SPECIFICATIONS

$V_{CC} = 3.3 \text{ V} \pm 0.3 \text{ V}$, $C1$ to $C4 = 0.1 \mu\text{F}$, $-40^\circ\text{C} \leq T_A \leq +85^\circ\text{C}$, unless otherwise noted.

Table 1.

| Parameter | Test Conditions/Comments | Min | Typ | Max | Unit |
|---|--|----------------|-----------|-----|------------------------|
| DC CHARACTERISTICS | | | | | |
| Operating Voltage Range | | 3.0 | 3.3 | 5.5 | V |
| Power Supply Current, V_{CC} | No load | | 1.5 | 2.6 | mA |
| | $R_L = 3 \text{ k}\Omega$ to GND | | 5 | 7 | mA |
| LOGIC | | | | | |
| Input Logic Threshold Low, V_{INL} | T_{IN} | | | 0.6 | V |
| Input Logic Threshold High, V_{INH} | T_{IN} | 1.4 | | | V |
| Input Logic Threshold Low, V_{INL} | $T_{IN}, V_{CC} = 5.0 \text{ V} \pm 0.5 \text{ V}$ | | | 0.8 | V |
| Input Logic Threshold High, V_{INH} | $T_{IN}, V_{CC} = 5.0 \text{ V} \pm 0.5 \text{ V}$ | 2.0 | | | V |
| CMOS Output Voltage Low, V_{OL} | $I_{OUT} = 1.6 \text{ mA}$ | | | 0.4 | V |
| CMOS Output Voltage High, V_{OH} | $I_{OUT} = -1 \text{ mA}$ | $V_{CC} - 0.6$ | | | V |
| Logic Pull-Up Current | $T_{IN} = \text{GND to } V_{CC}$ | | 5 | 12 | μA |
| RS-232 RECEIVER | | | | | |
| EIA/TIA-232E Input Voltage Range ¹ | $V_{CC} = 3.0 \text{ V to } 5.5 \text{ V}$ | -30 | | +30 | V |
| EIA/TIA-232E Input Threshold Low | | 0.6 | 1.3 | | V |
| EIA/TIA-232E Input Threshold High | | | 1.6 | 2.4 | V |
| EIA/TIA-232E Input Hysteresis | | | 0.4 | | V |
| EIA/TIA-232E Input Resistance | | 3 | 5 | 7 | $\text{k}\Omega$ |
| TRANSMITTER | | | | | |
| Output Voltage Swing | | | | | |
| RS-232 | $V_{CC} = 3.3 \text{ V to } 5.5 \text{ V}$; transmitter output loaded with $3 \text{ k}\Omega$ to ground | ± 5.0 | ± 5.7 | | V |
| RS-562 | $V_{CC} = 3.0 \text{ V}$ | ± 4.5 | | | V |
| Transmitter Output Resistance | $V_{CC} = 0 \text{ V}, V_{OUT} = \pm 2 \text{ V}^1$ | 300 | | | Ω |
| RS-232 Output Short-Circuit Current | | | ± 15 | | mA |
| TIMING CHARACTERISTICS | | | | | |
| Maximum Data Rate | $V_{CC} = 3.3 \text{ V}, R_L = 3 \text{ k}\Omega$ to $7 \text{ k}\Omega, C_L = 50 \text{ pF to } 1000 \text{ pF}$ | 460 | | | kbps |
| Receiver Propagation Delay | | | | | |
| t_{PHL} | | | 0.4 | | μs |
| t_{PLH} | | | 0.4 | | μs |
| Transmitter Propagation Delay | $R_L = 3 \text{ k}\Omega, C_L = 1000 \text{ pF}$ | | 600 | | ns |
| Transmitter Skew | | | 80 | | ns |
| Receiver Skew | | | 70 | | ns |
| Transition Region Slew Rate | $+3 \text{ V to } -3 \text{ V or } -3 \text{ V to } +3 \text{ V}, V_{CC} = +3.3 \text{ V}, R_L = 3 \text{ k}\Omega, C_L = 1000 \text{ pF}, T_A = 25^\circ\text{C}^1$ | 5.5 | 10 | 30 | $\text{V}/\mu\text{s}$ |
| ESD PROTECTION | | | | | |
| RS-232 and CMOS I/O Pins | Human body model air discharge | | ± 15 | | kV |
| | Human body model contact discharge | | ± 8 | | kV |

¹ Guaranteed by design.

ABSOLUTE MAXIMUM RATINGS

$T_A = 25^\circ\text{C}$, unless otherwise noted.

Table 2.

| Parameter | Rating |
|---|---|
| V_{CC} | -0.3 V to +6 V |
| V+ | $(V_{CC} - 0.3\text{ V})$ to +13 V |
| V- | +0.3 V to -13 V |
| Input Voltages | |
| T_{IN} | -0.3 V to $(V_{CC} + 0.3\text{ V})$ |
| R_{IN} | $\pm 30\text{ V}$ |
| Output Voltages | |
| T_{OUT} | $\pm 15\text{ V}$ |
| R_{OUT} | -0.3 V to $(V_{CC} + 0.3\text{ V})$ |
| Short-Circuit Duration | |
| T_{OUT} | Continuous |
| Package Information | |
| θ_{JA} , Thermal Impedance (LFCSP) | 80°C/W |
| θ_{JA} , Thermal Impedance (QSOP) | 149.97°C/W |
| Operating Temperature Range | |
| Industrial (A Version) | -40°C to $+85^\circ\text{C}$ |
| Storage Temperature Range | -65°C to $+150^\circ\text{C}$ |
| Pb-Free Temperature (Soldering, 10 sec) | 260°C |

Stresses at or above those listed under Absolute Maximum Ratings may cause permanent damage to the product. This is a stress rating only; functional operation of the product at these or any other conditions above those indicated in the operational section of this specification is not implied. Operation beyond the maximum operating conditions for extended periods may affect product reliability.

ESD CAUTION



ESD (electrostatic discharge) sensitive device. Charged devices and circuit boards can discharge without detection. Although this product features patented or proprietary protection circuitry, damage may occur on devices subjected to high energy ESD. Therefore, proper ESD precautions should be taken to avoid performance degradation or loss of functionality.

PIN CONFIGURATIONS AND FUNCTION DESCRIPTIONS

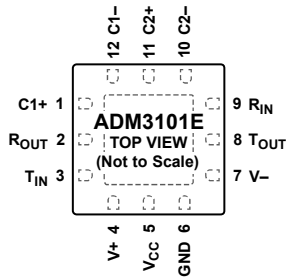

NOTES
 1. EXPOSED PAD. THE EXPOSED PAD MUST BE CONNECTED TO GND. THIS CONNECTION IS NOT REQUIRED TO MEET ELECTRICAL PERFORMANCE.

Figure 2. LFCSP Pin Configuration

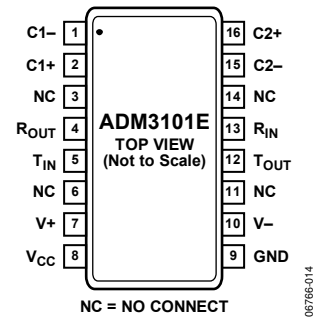

Figure 3. QSOP Pin Configuration

Table 3. Pin Function Descriptions

| Pin No. ¹ | | Mnemonic | Description |
|----------------------|--------------|------------------|---|
| LFCSP | QSOP | | |
| 1, 12 | 2, 1 | C1+, C1- | Positive and Negative Connections for Charge Pump Capacitor. External Capacitor C1 is connected between these pins; a 0.1 μF capacitor is recommended, but larger capacitors up to 10 μF can be used. |
| 2 | 4 | R _{OUT} | Receiver Output. This pin outputs CMOS output logic levels. |
| 3 | 5 | T _{IN} | Transmitter (Driver) Input. This input accepts TTL/CMOS levels. |
| 4 | 7 | V+ | Internally Generated Positive Supply (+6 V Nominal). |
| 5 | 8 | V _{CC} | Power Supply Input, 3.0 V to 5.5 V. |
| 6 | 9 | GND | Ground. Must be connected to 0 V. |
| 7 | 10 | V- | Internally Generated Negative Supply (-6 V Nominal). |
| 8 | 12 | T _{OUT} | Transmitter (Driver) Output. This pin outputs RS-232 signal levels (typically $\pm 6\text{ V}$). |
| 9 | 13 | R _{IN} | Receiver Input. This input accepts RS-232 signal levels. An internal 5 k Ω pull-down resistor to GND is connected on the input. |
| 10, 11 | 15, 16 | C2-, C2+ | Positive and Negative Connections for Charge Pump Capacitor. External Capacitor C2 is connected between these pins; a 0.1 μF capacitor is recommended, but larger capacitors up to 10 μF can be used. |
| N/A | 3, 6, 11, 14 | NC | No Connect. These pins should always remain unconnected. |
| EPAD | N/A | EPAD | Exposed Pad. The exposed pad must be connected to GND. This connection is not required to meet electrical performance. |

¹ N/A means not applicable.

TYPICAL PERFORMANCE CHARACTERISTICS

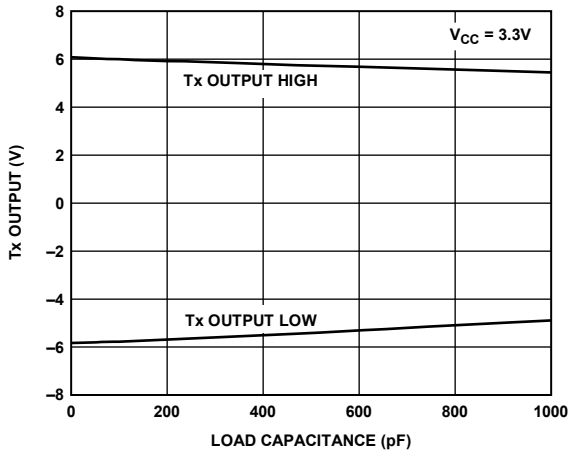

Figure 4. Transmitter Output Voltage High/Low vs. Load Capacitance @ 460 kbps

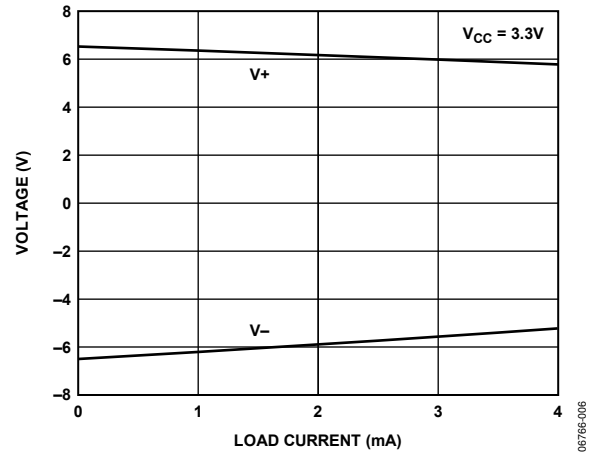

Figure 7. Charge Pump V+, V- vs. Load Current

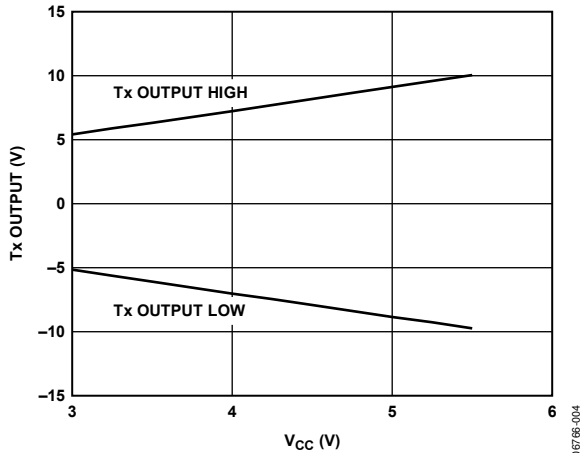

Figure 5. Transmitter Output Voltage High/Low vs. VCC, RL = 3 kΩ

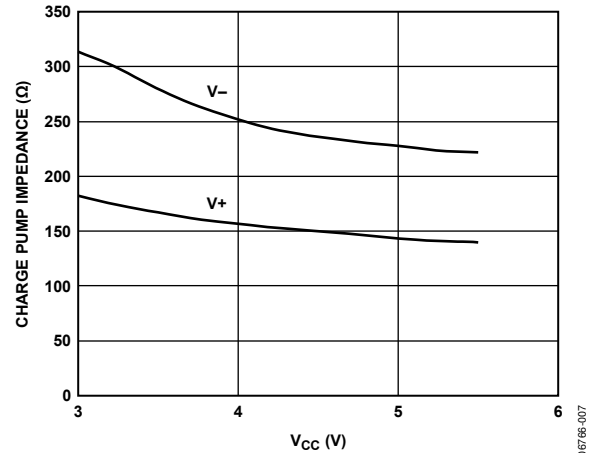

Figure 8. Charge Pump Impedance vs. VCC

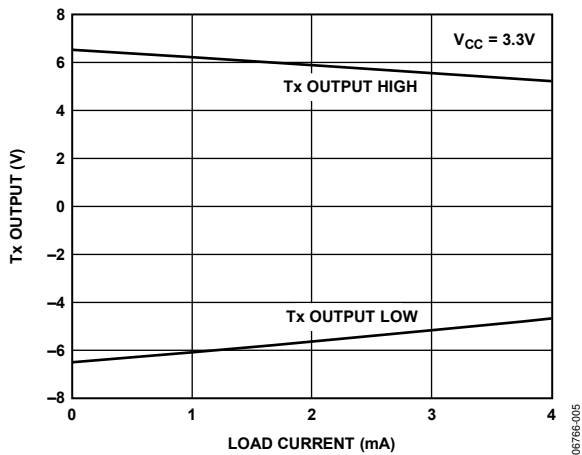

Figure 6. Transmitter Output Voltage High/Low vs. Load Current

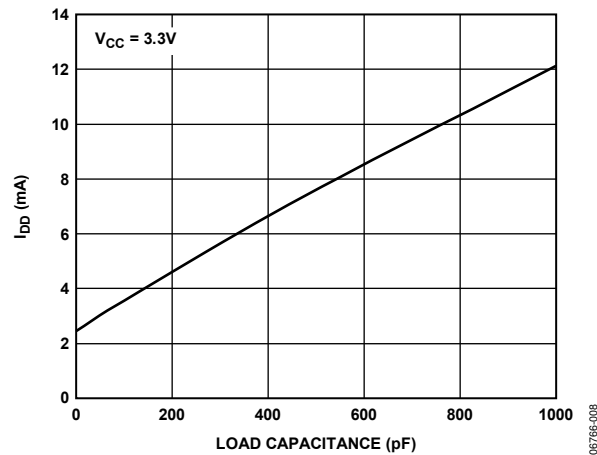

Figure 9. Power Supply Current vs. Load Capacitance

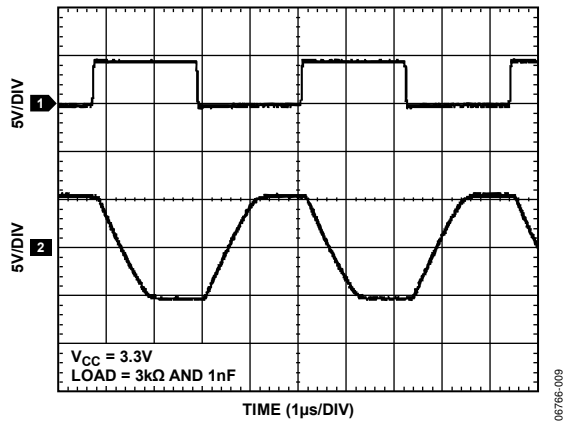

Figure 10. 460 kbps Data Transmission

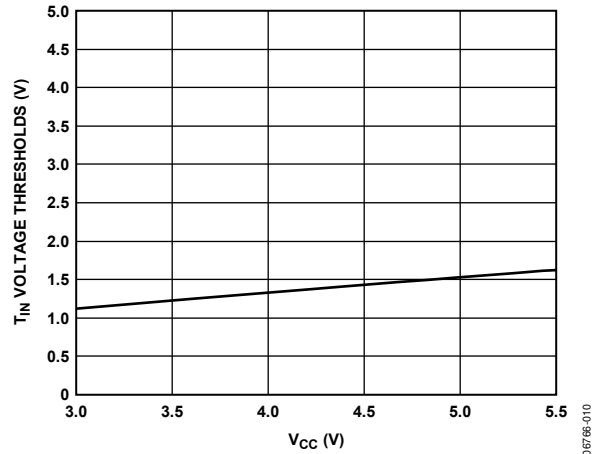

Figure 11. T_{IN} Voltage Threshold vs. V_{CC}

THEORY OF OPERATION

The **ADM3101E** is a single-channel RS-232 line driver/receiver. Step-up voltage converters, coupled with level shifting transmitters and receivers, allow RS-232 levels to be developed while operating from a single 3.3 V supply.

CMOS technology is used to keep the power dissipation to an absolute minimum, allowing maximum battery life in portable applications.

CIRCUIT DESCRIPTION

The internal circuitry consists of the following main sections:

- A charge pump voltage converter
- A 3.3 V logic to an EIA/TIA-232E transmitter
- An EIA/TIA-232E to a 3.3 V logic receiver

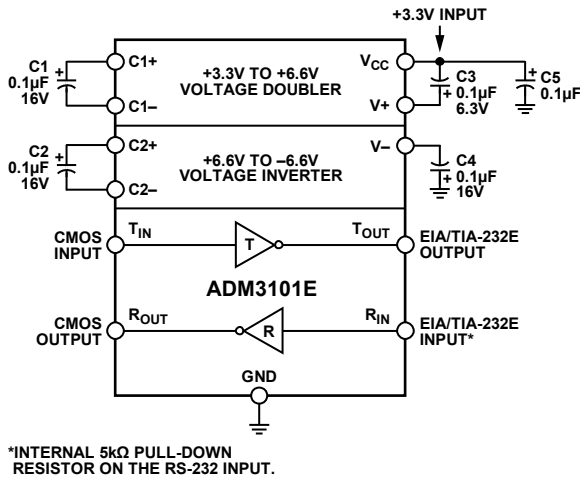

Figure 12. Typical Operating Circuit

Charge Pump Voltage Converter

The charge pump voltage converter consists of a 200 kHz oscillator and a switching matrix. The converter generates a ± 6.6 V supply (when unloaded) from the 3.3 V input level. This is achieved in two stages by using a switched capacitor technique, as illustrated in Figure 13 and Figure 14. First, the 3.3 V input supply is doubled to +6.6 V by using C1 as the charge storage element. The +6.6 V level is then inverted to generate -6.6 V using C2 as the storage element. C3 is shown connected between V+ and V_{CC} but is equally effective if connected between V+ and GND.

The C3 and C4 capacitors are used to reduce the output ripple. The values are not critical and can be increased, if desired. Larger capacitors (up to 10 μ F) can also be used in place of the C1, C2, C3, and C4 capacitors.

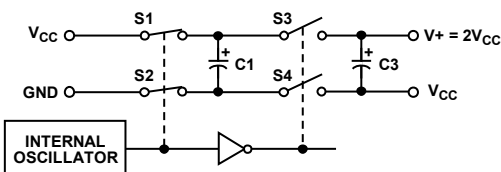

Figure 13. Charge Pump Voltage Doubler

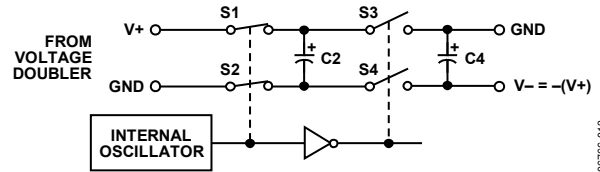

Figure 14. Charge Pump Voltage Inverter

3.3 V Logic to EIA/TIA-232E Transmitter

The transmitter driver converts the 3.3 V logic input levels into RS-232 output levels. When driving an RS-232 load with V_{CC} = 3.3 V, the output voltage swing is typically ± 6 V. Internally, the T_{IN} pin has a weak pull-up that allows it to be driven by an open-drain output, but the maximum operating data rate is reduced when the T_{IN} pin is driven by an open-drain pin.

EIA/TIA-232E to 3.3 V Logic Receiver

The receiver is an inverting level shifter that accepts the RS-232 input level and translates it into a 3.3 V logic output level. The input has an internal 5 k Ω pull-down resistor to ground and is protected against overvoltages of up to ± 30 V. An unconnected input is pulled to 0 V by the internal 5 k Ω pull-down resistor, which, therefore, results in a Logic 1 output level for an unconnected input or for an input connected to GND.

The receiver has a Schmitt trigger input with a hysteresis level of 0.4 V, which ensures error-free reception for both a noisy input and for an input with slow transition times.

CMOS Input Voltage Thresholds

The CMOS input and output pins (T_{IN} and R_{OUT}) of the **ADM3101E** are designed to interface with 1.8 V logic thresholds when V_{CC} = 3.3 V.

The CMOS input and output pins (T_{IN} and R_{OUT}) of the **ADM3101E** are also designed to interface with TTL/CMOS logic thresholds when V_{CC} = 5 V.

ESD Protection on RS-232 and CMOS I/O Pins

All RS-232 (T_{OUT} and R_{IN}) and CMOS (T_{IN} and R_{OUT}) inputs and outputs are protected against electrostatic discharges (up to ± 15 kV).

HIGH BAUD RATE

The **ADM3101E** features high slew rates, permitting data transmission at rates well in excess of the EIA/RS-232 specifications. The RS-232 voltage levels are maintained at data rates of up to 460 kbps, even under worst-case loading conditions, when T_{IN} is driven by a push-pull output. The slew rate is internally controlled to less than 30 V/ μ s to minimize EMI interference.

OUTLINE DIMENSIONS

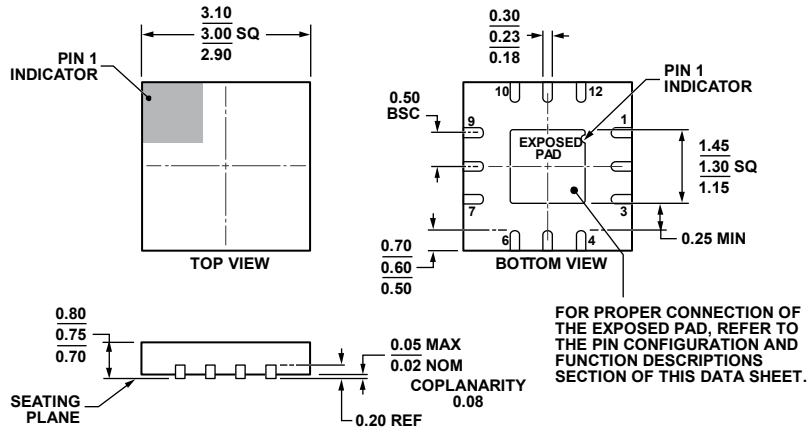

COMPLIANT TO JEDEC STANDARDS MO-220-WEED.

Figure 15. 12-Lead Lead Frame Chip Scale Package [LFCSP_WQ]
3 mm x 3 mm Body, Very Very Thin Quad
(CP-12-4)

Dimensions shown in millimeters

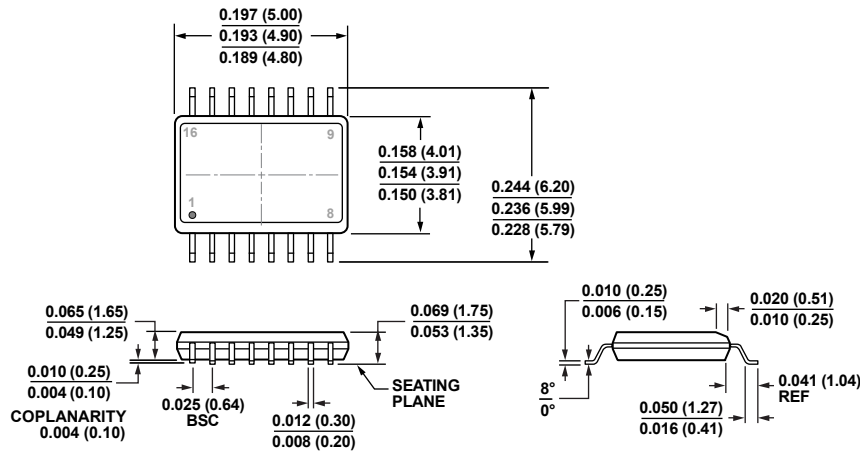

COMPLIANT TO JEDEC STANDARDS MO-137-AB

CONTROLLING DIMENSIONS ARE IN INCHES; MILLIMETER DIMENSIONS (IN PARENTHESES) ARE ROUNDED-OFF INCH EQUIVALENTS FOR REFERENCE ONLY AND ARE NOT APPROPRIATE FOR USE IN DESIGN.

Figure 16. 16-Lead Shrink Small Outline Package [QSOP]
(RQ-16)

Dimensions shown in inches and (millimeters)

ORDERING GUIDE

| Model ¹ | Temperature Range | Package Description | Package Option | Branding |
|--------------------|-------------------|--|----------------|----------|
| ADM3101EACPZ-REEL | -40°C to +85°C | 12-Lead Lead Frame Chip Scale Package [LFCSP_WQ] | CP-12-4 | MA6 |
| ADM3101EACPZ-250R7 | -40°C to +85°C | 12-Lead Lead Frame Chip Scale Package [LFCSP_WQ] | CP-12-4 | MA6 |
| ADM3101EARQZ | -40°C to +85°C | 16-Lead Shrink Small Outline Package [QSOP] | RQ-16 | |
| ADM3101EARQZ-REEL | -40°C to +85°C | 16-Lead Shrink Small Outline Package [QSOP] | RQ-16 | |

¹ Z = RoHS Compliant Part.

NOTES

NOTES

NOTES