



Chipsmall Limited consists of a professional team with an average of over 10 year of expertise in the distribution of electronic components. Based in Hongkong, we have already established firm and mutual-benefit business relationships with customers from,Europe,America and south Asia,supplying obsolete and hard-to-find components to meet their specific needs.

With the principle of "Quality Parts,Customers Priority,Honest Operation,and Considerate Service",our business mainly focus on the distribution of electronic components. Line cards we deal with include Microchip,ALPS,ROHM,Xilinx,Pulse,ON,Everlight and Freescale. Main products comprise IC,Modules,Potentiometer,IC Socket,Relay,Connector.Our parts cover such applications as commercial,industrial, and automotives areas.

We are looking forward to setting up business relationship with you and hope to provide you with the best service and solution. Let us make a better world for our industry!



## Contact us

Tel: +86-755-8981 8866 Fax: +86-755-8427 6832

Email & Skype: info@chipsmall.com Web: www.chipsmall.com

Address: A1208, Overseas Decoration Building, #122 Zhenhua RD., Futian, Shenzhen, China



### FEATURES

- Exceeds SONET requirements for jitter transfer/generation/tolerance
- Patented clock recovery architecture
- No reference clock required
- Loss-of-lock indicator
- I<sup>2</sup>C<sup>®</sup> interface to access optional features
- Single-supply operation: 3.3 V
- Low power: 359 mW typical
- 5 mm × 5 mm, 32-lead LFCSP, Pb free

### APPLICATIONS

- BPON ONT
- SONET OC-12
- WDM transponders
- Regenerators/repeaters
- Test equipment
- Broadband cross-connects and routers

### GENERAL DESCRIPTION

The ADN2806 provides the receiver functions for clock and data recovery, and data retiming for 622 Mbps NRZ data. The ADN2806 automatically locks to 622 Mbps data without the need for an external reference clock or programming. All SONET jitter requirements are met, including jitter transfer, jitter generation, and jitter tolerance. All specifications are quoted for -40°C to +85°C ambient temperature, unless otherwise noted.

This device, together with a PIN diode, TIA preamplifier, and a lim amp can implement a highly integrated, low cost, low power fiber optic receiver.

The ADN2806 is available in a compact 5 mm × 5 mm, 32-lead LFCSP.

### FUNCTIONAL BLOCK DIAGRAM

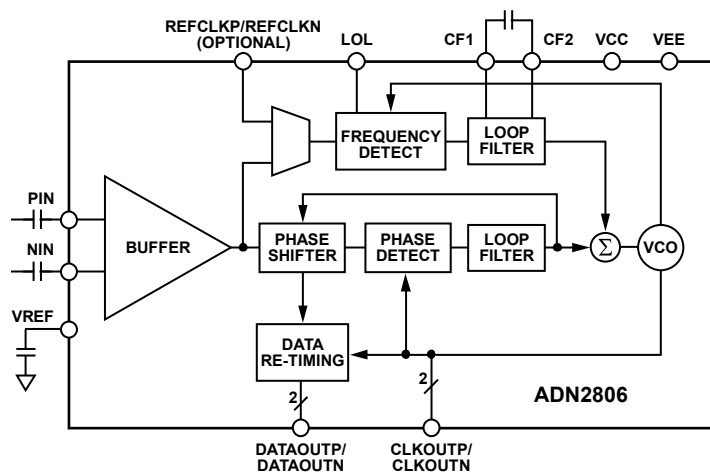

Figure 1.

### Rev. C

Information furnished by Analog Devices is believed to be accurate and reliable. However, no responsibility is assumed by Analog Devices for its use, nor for any infringements of patents or other rights of third parties that may result from its use. Specifications subject to change without notice. No license is granted by implication or otherwise under any patent or patent rights of Analog Devices. Trademarks and registered trademarks are the property of their respective owners.

# ADN2806\* PRODUCT PAGE QUICK LINKS

Last Content Update: 02/23/2017

---

## COMPARABLE PARTS

View a parametric search of comparable parts.

## EVALUATION KITS

- ADN2806 Evaluation Board

## DOCUMENTATION

### Application Notes

- AN-657: ADN2812 Evaluation Board
- AN-851: A WiMax Double Downconversion IF Sampling Receiver Design

### Data Sheet

- ADN2806: 622 Mbps Clock and Data Recovery IC Datasheet

## DESIGN RESOURCES

- ADN2806 Material Declaration
- PCN-PDN Information
- Quality And Reliability
- Symbols and Footprints

## DISCUSSIONS

View all ADN2806 EngineerZone Discussions.

## SAMPLE AND BUY

Visit the product page to see pricing options.

## TECHNICAL SUPPORT

Submit a technical question or find your regional support number.

## DOCUMENT FEEDBACK

Submit feedback for this data sheet.

---

## TABLE OF CONTENTS

Features .....	1	Jitter Specifications .....	10
Applications .....	1	Theory of Operation .....	11
General Description .....	1	Functional Description .....	13
Functional Block Diagram .....	1	Frequency Acquisition .....	13
Revision History .....	2	Input Buffer Amplifier .....	13
Specifications .....	3	Lock Detector Operation .....	13
Jitter Specifications .....	3	SQUELCH Modes .....	13
Output and Timing Specifications .....	4	I <sup>2</sup> C Interface .....	14
Absolute Maximum Ratings .....	5	Reference Clock (Optional) .....	15
Thermal Characteristics .....	5	Applications Information .....	17
ESD Caution .....	5	PCB Design Guidelines .....	17
Timing Characteristics .....	6	Outline Dimensions .....	20
Pin Configuration and Function Descriptions .....	7	Ordering Guide .....	20
I <sup>2</sup> C Interface Timing and Internal Register Description .....	8		

## REVISION HISTORY

### 4/12—Rev. B to Rev. C

Change to General Description Section .....	1
Change to Output Clock Range Parameter, Table 1 .....	3
Changed Pin 1 from VCC to TEST1 and Pin 32 from VCC to TEST2 Throughout; Changes to Figure 5 and Table 5 .....	7
Changes to Table 6 and Table 10 .....	9
Changes to Ordering Guide; Updated Outline Dimensions .....	20

### 5/10—Rev. A to Rev. B

Changes to Figure 5 and Table 5 .....	7
Changes to Figure 19 .....	17

### 2/09—Rev. 0 to Rev. A

Updated Outline Dimensions .....	20
Changes to Ordering Guide .....	20

### 2/06—Revision 0: Initial Version

## SPECIFICATIONS

$T_A = T_{MIN}$  to  $T_{MAX}$ ,  $V_{CC} = V_{MIN}$  to  $V_{MAX}$ ,  $V_{EE} = 0$  V,  $C_F = 0.47$   $\mu$ F, SLICEP = SLICEN = VEE, input data pattern: PRBS  $2^{23} - 1$ , unless otherwise noted.

**Table 1.**

Parameter	Conditions	Min	Typ	Max	Unit
<b>DATA INPUTS—DC CHARACTERISTICS</b>					
Input Voltage Range	@ PIN or NIN, dc-coupled	1.8		2.8	V
Peak-to-Peak Differential Input	PIN – NIN	0.2		2.0	V
Input Common-Mode Level	DC-coupled	2.3	2.5	2.8	V
<b>DATA INPUTS—AC CHARACTERISTICS</b>					
Data Rate			622		Mbps
S11	@ 622 MHz		–15		dB
Output Clock Range	Locked to 622 Mbps input data		622		MHz
Input Resistance	Differential		100		$\Omega$
Input Capacitance			0.65		pF
<b>LOSS-OF-LOCK (LOL) DETECT</b>					
VCO Frequency Error for LOL Assert	With respect to nominal		1000		ppm
VCO Frequency Error for LOL Deassert	With respect to nominal		250		ppm
LOL Response Time	OC-12		200		$\mu$ s
<b>ACQUISITION TIME</b>					
Lock to Data Mode	OC-12		2.0		ms
Optional Lock to REFCLK Mode			20.0		ms
<b>DATA RATE READBACK ACCURACY</b>					
Fine Readback	In addition to REFCLK accuracy OC-12		100		ppm
<b>POWER SUPPLY VOLTAGE</b>					
		3.0	3.3	3.6	V
<b>POWER SUPPLY CURRENT</b>					
	Locked to 622.08 Mbps		109		mA
<b>OPERATING TEMPERATURE RANGE</b>					
		–40		+85	$^{\circ}$ C

## JITTER SPECIFICATIONS

$T_A = T_{MIN}$  to  $T_{MAX}$ ,  $V_{CC} = V_{MIN}$  to  $V_{MAX}$ ,  $V_{EE} = 0$  V,  $C_F = 0.47$   $\mu$ F, SLICEP = SLICEN = VEE, input data pattern: PRBS  $2^{23} - 1$ , unless otherwise noted.

**Table 2.**

Parameter	Conditions	Min	Typ	Max	Unit
<b>PHASE-LOCKED LOOP CHARACTERISTICS</b>					
Jitter Transfer Bandwidth	OC-12		75	130	kHz
Jitter Peaking	OC-12		0	0.03	dB
Jitter Generation	OC-12, 12 kHz to 5 MHz		0.001	0.003	UI rms
			0.011	0.026	UI p-p
Jitter Tolerance	OC-12, $2^{23} - 1$ PRBS				
	30 Hz <sup>1</sup>	100			UI p-p
	300 Hz <sup>1</sup>	44			UI p-p
	25 kHz	2.5			UI p-p
	250 kHz <sup>1</sup>	1.0			UI p-p

<sup>1</sup> Jitter tolerance of the ADN2806 at these jitter frequencies is better than what the test equipment is able to measure.

# ADN2806

## OUTPUT AND TIMING SPECIFICATIONS

Table 3.

Parameter	Conditions	Min	Typ	Max	Unit
<b>LVDS OUTPUT CHARACTERISTICS</b> (CLKOUTP/CLKOUTN, DATAOUTP/DATAOUTN)					
Output Voltage High	$V_{OH}$ (see Figure 3)			1475	mV
Output Voltage Low	$V_{OL}$ (see Figure 3)	925			mV
Differential Output Swing	$V_{OD}$ (see Figure 3)	250	320	400	mV
Output Offset Voltage	$V_{OS}$ (see Figure 3)	1125	1200	1275	mV
Output Impedance	Differential		100		$\Omega$
<b>LVDS Outputs' Timing</b>					
Rise Time	20% to 80%		115	220	ps
Fall Time	80% to 20%		115	220	ps
Setup Time	$T_S$ (see Figure 2), OC-12	760	800	840	ps
Hold Time	$T_H$ (see Figure 2), OC-12	760	800	840	ps
<b>I<sup>2</sup>C INTERFACE DC CHARACTERISTICS</b>					
Input High Voltage	$V_{IH}$	0.7 VCC			V
Input Low Voltage	$V_{IL}$			0.3 VCC	V
Input Current	$V_{IN} = 0.1 VCC$ or $V_{IN} = 0.9 VCC$	-10.0		+10.0	$\mu A$
Output Low Voltage	$V_{OL}, I_{OL} = 3.0 mA$			0.4	V
<b>I<sup>2</sup>C INTERFACE TIMING</b>					
SCK Clock Frequency	See Figure 10			400	kHz
SCK Pulse Width High	$t_{HIGH}$	600			ns
SCK Pulse Width Low	$t_{LOW}$	1300			ns
Start Condition Hold Time	$t_{HD,STA}$	600			ns
Start Condition Setup Time	$t_{SU,STA}$	600			ns
Data Setup Time	$t_{SU,DAT}$	100			ns
Data Hold Time	$t_{HD,DAT}$	300			ns
SCK/SDA Rise/Fall Time	$T_R/T_F$	$20 + 0.1 C_b^1$		300	ns
Stop Condition Setup Time	$t_{SU,STO}$	600			ns
Bus Free Time Between a Stop and a Start	$t_{BUF}$	1300			ns
<b>REFCLK CHARACTERISTICS</b>					
Input Voltage Range	Optional lock to REFCLK mode @ REFCLKP or REFCLKN				
	$V_{IL}$		0		V
	$V_{IH}$		VCC		V
Minimum Differential Input Drive			100		mV p-p
Reference Frequency		10		160	MHz
Required Accuracy			100		ppm
<b>LVTTL DC INPUT CHARACTERISTICS</b>					
Input High Voltage	$V_{IH}$	2.0			V
Input Low Voltage	$V_{IL}$			0.8	V
Input High Current	$I_{IH}, V_{IN} = 2.4 V$			5	$\mu A$
Input Low Current	$I_{IL}, V_{IN} = 0.4 V$	-5			$\mu A$
<b>LVTTL DC OUTPUT CHARACTERISTICS</b>					
Output High Voltage	$V_{OH}, I_{OH} = -2.0 mA$	2.4			V
Output Low Voltage	$V_{OL}, I_{OL} = +2.0 mA$			0.4	V

<sup>1</sup>  $C_b$  = total capacitance of one bus line in picofarads. If used with HS-mode devices, faster fall times are allowed.



## ABSOLUTE MAXIMUM RATINGS

$T_A = T_{MIN}$  to  $T_{MAX}$ ,  $V_{CC} = V_{MIN}$  to  $V_{MAX}$ ,  $V_{EE} = 0$  V,  $C_F = 0.47$   $\mu$ F, unless otherwise noted.

Table 4.

Parameter	Rating
Supply Voltage (VCC)	4.2 V
Minimum Input Voltage (All Inputs)	$V_{EE} - 0.4$ V
Maximum Input Voltage (All Inputs)	$V_{CC} + 0.4$ V
Maximum Junction Temperature	125°C
Storage Temperature Range	-65°C to +150°C

Stress above those listed under Absolute Maximum Ratings may cause permanent damage to the device. This is a stress rating only; functional operation of the device at these or any other conditions above those indicated in the operational sections of this specification is not implied. Exposure to absolute maximum rating conditions for extended periods may affect device reliability.

## THERMAL CHARACTERISTICS

### Thermal Resistance

32-lead LFCSP, 4-layer board with exposed paddle soldered to  $V_{EE}$ ,  $\theta_{JA} = 28^\circ\text{C/W}$ .

## ESD CAUTION

ESD (electrostatic discharge) sensitive device. Electrostatic charges as high as 4000 V readily accumulate on the human body and test equipment and can discharge without detection. Although this product features proprietary ESD protection circuitry, permanent damage may occur on devices subjected to high energy electrostatic discharges. Therefore, proper ESD precautions are recommended to avoid performance degradation or loss of functionality.



TIMING CHARACTERISTICS

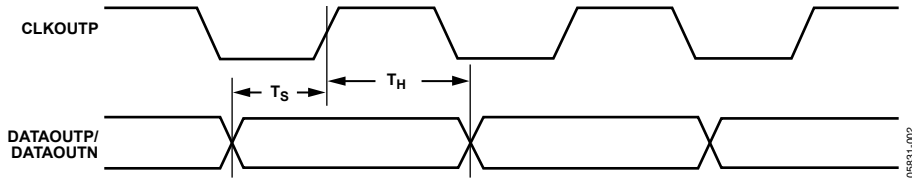

Figure 2. Output Timing

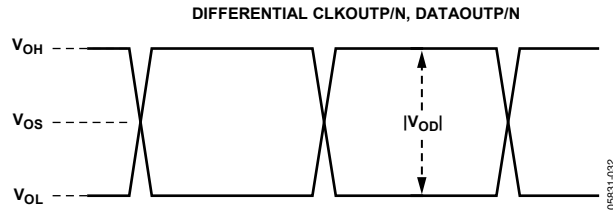

Figure 3. Differential Output Specifications

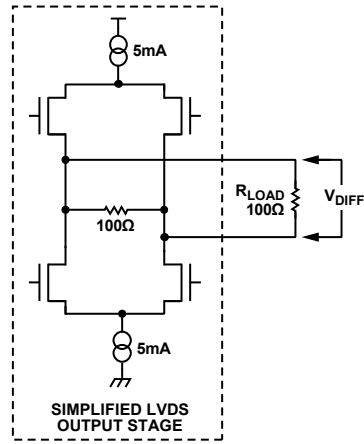
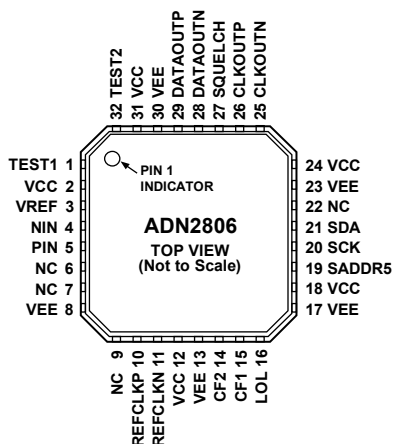

Figure 4. Differential Output Stage



## PIN CONFIGURATION AND FUNCTION DESCRIPTIONS



- NOTES**
1. NC = NO CONNECT.
  2. THERE IS AN EXPOSED PAD ON THE BOTTOM OF THE PACKAGE THAT MUST BE CONNECTED TO GND.

05831-004

Figure 5. Pin Configuration

Table 5. Pin Function Descriptions

Pin No.	Mnemonic	Type <sup>1</sup>	Description
1	TEST1	AI	Connect to VCC.
2	VCC	P	Power for Limiting Amplifier, LOS.
3	VREF	AO	Internal VREF Voltage. Decouple to GND with a 0.1 $\mu$ F capacitor.
4	NIN	AI	Differential Data Input. CML.
5	PIN	AI	Differential Data Input. CML.
6	NC		No Connect.
7	NC		No Connect.
8	VEE	P	GND for Limiting Amplifier, LOS.
9	NC		No Connect.
10	REFCLKP	DI	Differential REFCLK Input. 10 MHz to 160 MHz.
11	REFCLKN	DI	Differential REFCLK Input. 10 MHz to 160 MHz.
12	VCC	P	VCO Power.
13	VEE	P	VCO GND.
14	CF2	AO	Frequency Loop Capacitor.
15	CF1	AO	Frequency Loop Capacitor.
16	LOL	DO	Loss-of-Lock Indicator. LVTTTL active high.
17	VEE	P	FLL Detector GND.
18	VCC	P	FLL Detector Power.
19	SADDR5	DI	Slave Address Bit 5.
20	SCK	DI	I <sup>2</sup> C Clock Input.
21	SDA	DI	I <sup>2</sup> C Data Input.
22	NC		No Connect.
23	VEE	P	Output Buffer, I <sup>2</sup> C GND.
24	VCC	P	Output Buffer, I <sup>2</sup> C Power.
25	CLKOUTN	DO	Differential Recovered Clock Output. LVDS.
26	CLKOUTP	DO	Differential Recovered Clock Output. LVDS.
27	SQUELCH	DI	Disable Clock and Data Outputs. Active high. LVTTTL.
28	DATAOUTN	DO	Differential Recovered Data Output. LVDS.
29	DATAOUTP	DO	Differential Recovered Data Output. LVDS.
30	VEE	P	Phase Detector, Phase Shifter GND.
31	VCC	P	Phase Detector, Phase Shifter Power.
32	TEST2	AI	Connect to VCC.
Exposed Pad	Pad	P	Connect to GND. Works as a heat sink.

<sup>1</sup> Type: P = power, AI = analog input, AO = analog output, DI = digital input, DO = digital output.

# I<sup>2</sup>C INTERFACE TIMING AND INTERNAL REGISTER DESCRIPTION

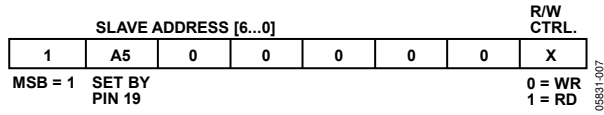

Figure 6. Slave Address Configuration

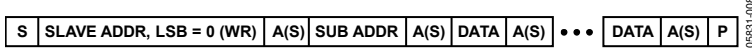

Figure 7. I<sup>2</sup>C Write Data Transfer

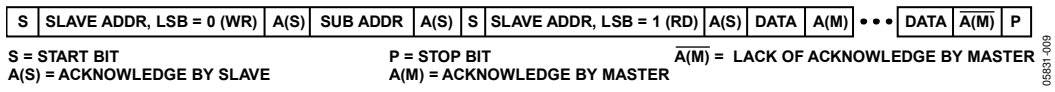

Figure 8. I<sup>2</sup>C Read Data Transfer

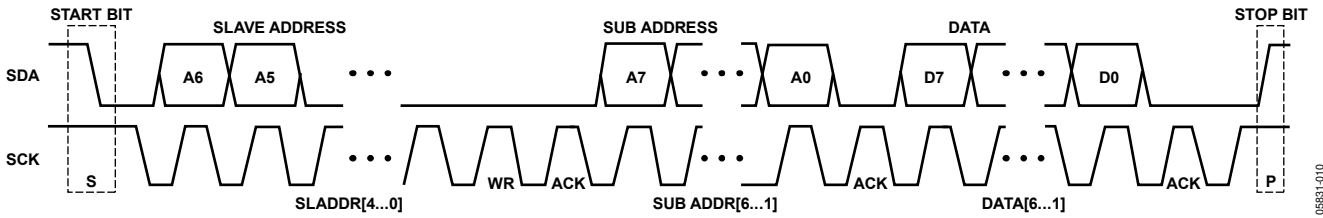

Figure 9. I<sup>2</sup>C Data Transfer Timing

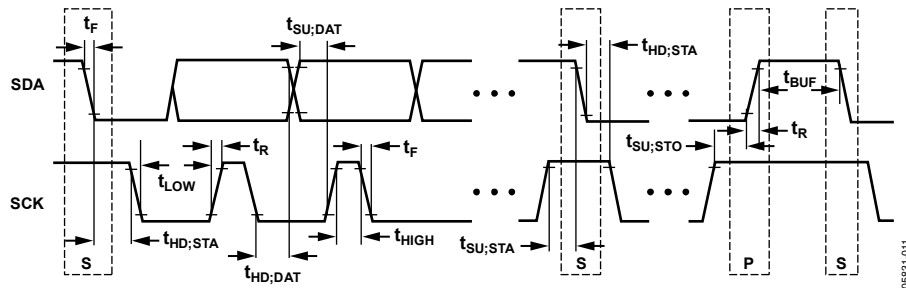

Figure 10. I<sup>2</sup>C Port Timing Diagram

Table 6. Internal Register Map<sup>1</sup>

Reg Name	R/W	Addr	D7	D6	D5	D4	D3	D2	D1	D0
FREQ0	R	0x0	MSB							LSB
FREQ1	R	0x1	MSB							LSB
FREQ2	R	0x2	0	MSB						LSB
MISC	R	0x4	x	x	LOS status	Static LOL	LOL status	Data rate measurement complete	x	x
CTRLA	W	0x8	F <sub>REF</sub> range		Data rate/DIV_F <sub>REF</sub> ratio				Measure data rate	Lock to reference
CTRLB	W	0x9	Config LOL	Reset MISC[4]	System reset	0	Reset MISC[2]	0	0	0
CTRLC	W	0x11	0	0	0	0	0	Config LOS	SQUELCH mode	0

<sup>1</sup> All writeable registers default to 0x00.

Table 7. Miscellaneous Register, MISC

D7	D6	D5	Static LOL D4	LOL Status D3	Data Rate Measurement Complete D2	D1	D0
x	x	x	0 = Waiting for next LOL 1 = Static LOL until reset	0 = Locked 1 = Acquiring	0 = Measuring data rate 1 = Measurement complete	x	x

Table 8. Control Register, CTRLA<sup>1</sup>

F <sub>REF</sub> Range			Data Rate/Div_F <sub>REF</sub> Ratio					Measure Data Rate D1	Lock to Reference D0
D7	D6		D5	D4	D3	D2			
0	0	19.44 MHz	0	1	0	1	32	Set to 1 to measure data rate	0 = Lock to input data 1 = Lock to reference clock
0	1	38.88 MHz	0	1	0	1	32		
1	0	77.76 MHz	0	1	0	1	32		
1	1	155.52 MHz	0	1	0	1	32		

<sup>1</sup> Where DIV\_F<sub>REF</sub> is the divided down reference referred to the 10 MHz to 20 MHz band (see the Reference Clock (Optional) section).

Table 9. Control Register, CTRLB

Config LOL D7	Reset MISC[4] D6	System Reset D5	D4	Reset MISC[2] D3	D2	D1	D0
0 = LOL pin normal operation 1 = LOL pin is static LOL	Write a 1 followed by 0 to reset MISC[4]	Write a 1 followed by 0 to reset ADN2806	Set to 0	Write a 1 followed by 0 to reset MISC[2]	Set to 0	Set to 0	Set to 0

Table 10. Control Register, CTRLC

D7	D6	D5	D4	D3	Config LOS D2	SQUELCH Mode D1	Output Boost D0
Set to 0	Set to 0	Set to 0	Set to 0	Set to 0	0 = Active high LOS 1 = Active low LOS	0 = Squelch data outputs and clock outputs 1 = Squelch data outputs or clock outputs	0 (Default output swing)

## JITTER SPECIFICATIONS

The ADN2806 CDR is designed to achieve the best bit-error-rate (BER) performance and to exceed the jitter transfer, generation, and tolerance specifications proposed for SONET/SDH equipment defined in the Telcordia Technologies specification.

Jitter is the dynamic displacement of digital signal edges from their long-term average positions, measured in unit intervals (UI), where 1 UI = 1 bit period. Jitter on the input data can cause dynamic phase errors on the recovered clock sampling edge. Jitter on the recovered clock causes jitter on the retimed data.

The following sections briefly summarize the specifications of jitter generation, transfer, and tolerance in accordance with the Telcordia document (GR-253-CORE, Issue 3, September 2000) for the optical interface at the equipment level and the ADN2806 performance with respect to those specifications.

### Jitter Generation

The jitter generation specification limits the amount of jitter that can be generated by the device with no jitter and wander applied at the input. For SONET devices, the jitter generated must be less than 0.01 UI rms and less than 0.1 UI p-p.

### Jitter Transfer

The jitter transfer function is the ratio of the jitter on the output signal to the jitter applied on the input signal vs. the frequency. This parameter measures the amount of jitter on an input signal that can be transferred to the output signal (see Figure 11). This amount is limited.

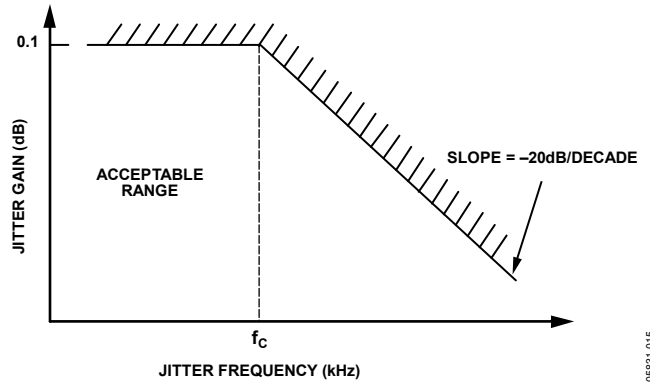

Figure 11. Jitter Transfer Curve

### Jitter Tolerance

The jitter tolerance is defined as the peak-to-peak amplitude of the sinusoidal jitter applied on the input signal, which causes a 1 dB power penalty. This is a stress test intended to ensure that no additional penalty is incurred under the operating conditions (see Figure 12).

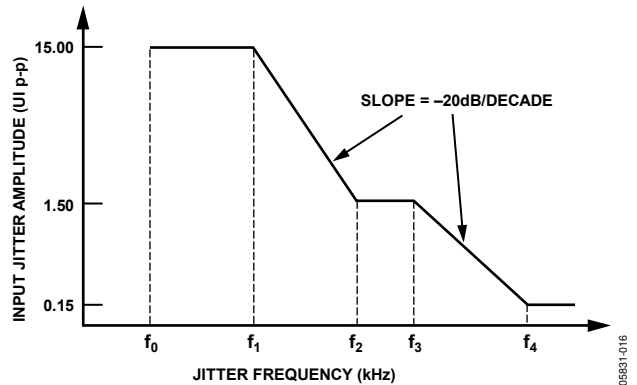

Figure 12. SONET Jitter Tolerance Mask

## THEORY OF OPERATION

The ADN2806 is a delay- and phase-locked loop circuit for clock recovery and data retiming from an NRZ encoded data stream. The phase of the input data signal is tracked by two separate feedback loops, which share a common control voltage. A high speed delay-locked loop path uses a voltage controlled phase shifter to track the high frequency components of input jitter. A separate phase control loop, composed of the VCO, tracks the low frequency components of input jitter. The initial frequency of the VCO is set by yet a third loop that compares the VCO frequency with the input data frequency and sets the coarse tuning voltage. The jitter tracking phase-locked loop controls the VCO by the fine-tuning control.

The delay and phase loops together track the phase of the input data signal. For example, when the clock lags the input data, the phase detector drives the VCO to a higher frequency and increases the delay through the phase shifter; both of these actions serve to reduce the phase error between the clock and the data. The faster clock picks up phase, whereas the delayed data loses phase. Because the loop filter is an integrator, the static phase error is driven to 0°.

Another view of the circuit is that the phase shifter implements the zero required for frequency compensation of a second-order phase-locked loop, and this zero is placed in the feedback path; therefore, it does not appear in the closed-loop transfer function. Jitter peaking in a conventional second-order phase-locked loop is caused by the presence of this zero in the closed-loop transfer function. Because this circuit has no zero in the closed-loop transfer, jitter peaking is minimized.

The delay and phase loops together simultaneously provide wideband jitter accommodation and narrow-band jitter filtering. The linearized block diagram in Figure 13 shows that the jitter transfer function,  $Z(s)/X(s)$ , provides excellent second-order low-pass filtering. Note that the jitter transfer has no zero, unlike an ordinary second-order phase-locked loop. This means that the main PLL loop has virtually no jitter peaking (see Figure 14), making this circuit ideal for signal regenerator applications, where jitter peaking in a cascade of regenerators can contribute to hazardous jitter accumulation.

The error transfer,  $e(s)/X(s)$ , has the same high-pass form as an ordinary phase-locked loop. This transfer function can be optimized to accommodate a significant amount of wideband jitter, because the jitter transfer function,  $Z(s)/X(s)$ , provides the narrow-band jitter filtering.

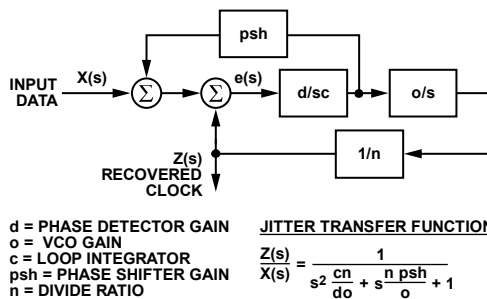

d = PHASE DETECTOR GAIN  
o = VCO GAIN  
c = LOOP INTEGRATOR  
psh = PHASE SHIFTER GAIN  
n = DIVIDE RATIO

**JITTER TRANSFER FUNCTION**  

$$\frac{Z(s)}{X(s)} = \frac{1}{s^2 \frac{cn}{do} + s \frac{n \text{ psh}}{o} + 1}$$

**TRACKING ERROR TRANSFER FUNCTION**  

$$\frac{e(s)}{X(s)} = \frac{s^2}{s^2 + s \frac{d \text{ psh}}{c} + \frac{do}{cn}}$$

Figure 13. PLL/DLL Architecture

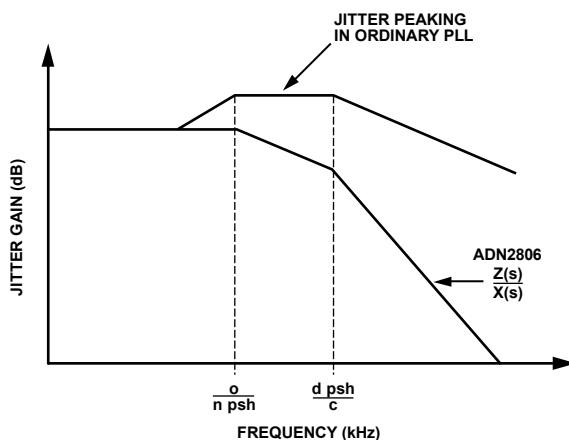

Figure 14. Jitter Response vs. Conventional PLL

The delay and phase loops contribute to overall jitter accommodation. At low frequencies of input jitter on the data signal, the integrator in the loop filter provides high gain to track large jitter amplitudes with small phase error. In this case, the VCO is frequency modulated, and jitter is tracked as in an ordinary phase-locked loop. The amount of low frequency jitter that can be tracked is a function of the VCO tuning range. A wider tuning range gives larger accommodation of low frequency jitter. The internal loop control voltage remains small for small phase errors; therefore, the phase shifter remains close to the center of its range and thus contributes little to the low frequency jitter accommodation.

At medium jitter frequencies, the gain and tuning range of the VCO are not large enough to track input jitter. In this case, the VCO control voltage becomes large and saturates, and the VCO frequency dwells at one extreme of its tuning range. The size of the VCO tuning range, therefore, has only a small effect on the jitter accommodation. The delay-locked loop control voltage is now larger; therefore, the phase shifter takes on the burden of tracking the input jitter. The phase shifter range, in UI, can be seen as a broad plateau on the jitter tolerance curve. The phase shifter has a minimum range of 2 UI at all data rates.

The gain of the loop integrator is small for high jitter frequencies; therefore, larger phase differences are needed to increase the loop control voltage enough to tune the range of the phase shifter. However, large phase errors at high jitter frequencies cannot be tolerated. In this region, the gain of the integrator determines the jitter accommodation. Because the gain of the loop integrator declines linearly with frequency, jitter accommodation is lower with higher jitter frequency. At the highest frequencies, the loop gain is very small, and little tuning of the phase shifter can be expected. In this case, jitter accommodation is determined by the eye opening of the input data, the static phase error, and the residual loop jitter generation. The jitter accommodation is roughly 0.5 UI in this region. The corner frequency between the declining slope and the flat region is the closed-loop bandwidth of the delay-locked loop, which is roughly 1.0 MHz at 622 Mbps.

## FUNCTIONAL DESCRIPTION

### FREQUENCY ACQUISITION

The ADN2806 acquires frequency from the data. The lock detector circuit compares the frequency of the VCO and the frequency of the incoming data. When these frequencies differ by more than 1000 ppm, LOL is asserted. This initiates a frequency acquisition cycle. When the VCO frequency is within 250 ppm of the data frequency, LOL is deasserted.

Once LOL is deasserted, the frequency-locked loop is turned off. The PLL/DLL pulls the VCO frequency in the rest of the way until the VCO frequency equals the data frequency.

The frequency loop requires a single external capacitor between CF1 and CF2, Pin 14 and Pin 15. A  $0.47 \mu\text{F} \pm 20\%$ , X7R ceramic chip capacitor with  $<10 \text{ nA}$  leakage current is recommended. Leakage current of the capacitor can be calculated by dividing the maximum voltage across the  $0.47 \mu\text{F}$  capacitor,  $\sim 3 \text{ V}$ , by the insulation resistance of the capacitor. The insulation resistance of the  $0.47 \mu\text{F}$  capacitor should be greater than  $300 \text{ M}\Omega$ .

### INPUT BUFFER AMPLIFIER

The input buffer has differential inputs (PIN/NIN), which are internally terminated with  $50 \Omega$  to an on-chip voltage reference ( $V_{\text{REF}} = 2.5 \text{ V}$  typically). The minimum differential input level required to achieve a BER of  $10^{-10}$  is  $200 \text{ mV p-p}$ .

### LOCK DETECTOR OPERATION

The lock detector on the ADN2806 has three modes of operation: normal mode, REFCLK mode, and static LOL mode.

#### Normal Mode

In normal mode, the ADN2806 is a CDR that locks onto a 622 Mbps data rate without the use of a reference clock as an acquisition aid. In this mode, the lock detector monitors the frequency difference between the VCO and the input data frequency and deasserts the loss of lock signal, which appears on Pin 16, LOL, when the VCO is within 250 ppm of the data frequency. This enables the D/PLL, which pulls the VCO frequency in the remaining amount and acquires phase lock. Once locked, if the input frequency error exceeds 1000 ppm (0.1%), the loss-of-lock signal is reasserted and control returns to the frequency loop, which begins a new frequency acquisition. The LOL pin remains asserted until the VCO locks onto a valid input data stream to within 250 ppm frequency error. This hysteresis is shown in Figure 15.

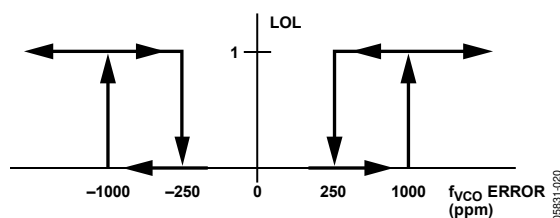

Figure 15. Transfer Function of LOL

### LOL Detector Operation Using a Reference Clock

In REFCLK mode, a reference clock is used as an acquisition aid to lock the ADN2806 VCO. Lock-to-reference mode is enabled by setting CTRLA[0] to 1. The user also needs to write to the CTRLA[7, 6] and CTRLA[5:2] bits to set the reference frequency range and the divide ratio of the data rate with respect to the reference frequency. For more details, see the Reference Clock (Optional) section. In this mode, the lock detector monitors the difference in frequency between the divided down VCO and the divided down reference clock. The loss-of-lock signal, which appears on Pin 16, LOL, is deasserted when the VCO is within 250 ppm of the desired frequency. This enables the D/PLL, which pulls the VCO frequency in the remaining amount with respect to the input data and acquires phase lock. Once locked, if the input frequency error exceeds 1000 ppm (0.1%), the loss-of-lock signal is reasserted and control returns to the frequency loop, which reacquires with respect to the reference clock. The LOL pin remains asserted until the VCO frequency is within 250 ppm of the desired frequency. This hysteresis is shown in Figure 15.

### Static LOL Mode

The ADN2806 implements a static LOL feature that indicates if a loss-of-lock condition has ever occurred. This feature remains asserted, even if the ADN2806 regains lock, until the static LOL bit is manually reset. The I<sup>2</sup>C register bit, MISC[4], is the static LOL bit. If there is ever an occurrence of a loss-of-lock condition, this bit is internally asserted to logic high. The MISC[4] bit remains high even after the ADN2806 has reacquired lock to a new data rate. This bit can be reset by writing a 1 followed by 0 to I<sup>2</sup>C Register Bit CTRLB[6]. Once reset, the MISC[4] bit remains deasserted until another loss-of-lock condition occurs.

Writing a 1 to I<sup>2</sup>C Register Bit CTRLB[7] causes the LOL pin, Pin 16, to become a static LOL indicator. In this mode, the LOL pin mirrors the contents of the MISC[4] bit and has the functionality described in the previous paragraph. The CTRLB[7] bit defaults to 0. In this mode, the LOL pin operates in the normal operating mode, that is, it is asserted only when the ADN2806 is in acquisition mode and deasserts when the ADN2806 has reacquired lock.

### SQUELCH MODES

Two modes for the SQUELCH pin are available with the ADN2806: squelch data outputs and clock outputs mode and squelch data outputs or clock outputs mode. Squelch data outputs and clock outputs mode is selected when CTRLC[1] is 0 (default mode). In this mode, when the SQUELCH input, Pin 27, is driven to a TTL high state, both the data outputs (DATAOUTN and DATAOUTP) and the clock outputs (CLKOUTN and CLKOUTP) are set to the zero state to suppress downstream processing. If the squelch function is not required, Pin 27 should be tied to VEE.



# ADN2806

Squelch data outputs or clock outputs mode is selected when CTRLC[1] is 1. In this mode, when the SQUELCH input is driven to a high state, the DATAOUTN and DATAOUTP pins are squelched. When the SQUELCH input is driven to a low state, the CLKOUTN and CLKOUTP pins are squelched. This is especially useful in repeater applications, where the recovered clock may not be needed.

## I<sup>2</sup>C INTERFACE

The ADN2806 supports a 2-wire, I<sup>2</sup>C-compatible serial bus driving multiple peripherals. Two inputs, serial data (SDA) and serial clock (SCK), carry information to and from any device connected to the bus. Each slave device is recognized by a unique address. The ADN2806 has two possible 7-bit slave addresses for both read and write operations. The MSB of the 7-bit slave address is factory programmed to 1. B5 of the slave address is set by Pin 19, SADDR5. Slave Address Bits [4:0] are defaulted to all 0s. The slave address consists of the seven MSBs of an 8-bit word. The LSB of the word either sets a read or write operation (see Figure 6). Logic 1 corresponds to a read operation, while Logic 0 corresponds to a write operation.

To control the device on the bus, the following protocol must be followed. First, the master initiates a data transfer by establishing a start condition, defined by a high-to-low transition on SDA while SCK remains high. This indicates that an address/data stream follows. All peripherals respond to the start condition and shift the next eight bits (the 7-bit address and the R/W bit). The bits are transferred from MSB to LSB. The peripheral that recognizes the transmitted address responds by pulling the data line low during the ninth clock pulse. This is known as an acknowledge bit. All other devices withdraw from the bus at this point and maintain an idle condition. The idle condition is where the device monitors the SDA and SCK lines, waiting for the start condition and correct transmitted address. The R/W bit determines the direction of the data. Logic 0 on the LSB of the first byte means that the master writes information to the peripheral. Logic 1 on the LSB of the first byte means that the master reads information from the peripheral.

The ADN2806 acts as a standard slave device on the bus. The data on the SDA pin is eight bits long, supporting the 7-bit addresses plus the R/W bit. The ADN2806 has eight subaddresses to enable the user-accessible internal registers (see Table 6 through Table 10). It, therefore, interprets the first byte as the device address and the second byte as the starting subaddress. Auto-increment mode is supported, allowing data to be read from or written to the starting subaddress and each subsequent address without manually addressing the subsequent subaddress. A data transfer is always terminated by a stop condition. The user can also access any unique subaddress register on a one-by-one basis without updating all registers.

Stop and start conditions can be detected at any stage of the data transfer. If these conditions are asserted out of sequence with normal read and write operations, they cause an immediate jump to the idle condition. During a given SCK high period, the user should issue one start condition, one stop condition, or a single stop condition followed by a single start condition. If an invalid subaddress is issued by the user, the ADN2806 does not issue an acknowledge and returns to the idle condition. If the user exceeds the highest subaddress while reading back in auto-increment mode, then the highest subaddress register contents continue to be output until the master device issues a no acknowledge. This indicates the end of a read. In a no-acknowledge condition, the SDA line is not pulled low on the ninth pulse. See Figure 7 and Figure 8 for sample write and read data transfers and Figure 9 for a more detailed timing diagram.

### **Additional Features Available via the I<sup>2</sup>C Interface**

#### **System Reset**

A frequency acquisition can be initiated by writing a 1 followed by a 0 to the I<sup>2</sup>C Register Bit CTRLB[5]. This initiates a new frequency acquisition while keeping the ADN2806 in its previously programmed operating mode, as set in Registers CTRL[A], CTRL[B], and CTRL[C].

## REFERENCE CLOCK (OPTIONAL)

A reference clock is not required to perform clock and data recovery with the ADN2806; however, support for an optional reference clock is provided. The reference clock can be driven differentially or in a single-ended fashion. If the reference clock is not being used, REFCLKP should be tied to VCC, and REFCLKN can be left floating or tied to VEE (the inputs are internally terminated to VCC/2). See Figure 16 through Figure 18 for sample configurations.

The REFCLK input buffer accepts any differential signal with a peak-to-peak differential amplitude of greater than 100 mV (for example, LVPECL or LVDS) or a standard single-ended, low voltage TTL input, providing maximum system flexibility. Phase noise and duty cycle of the reference clock are not critical, and 100 ppm accuracy is sufficient.

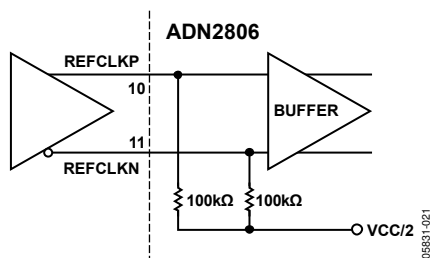

Figure 16. Differential REFCLK Configuration

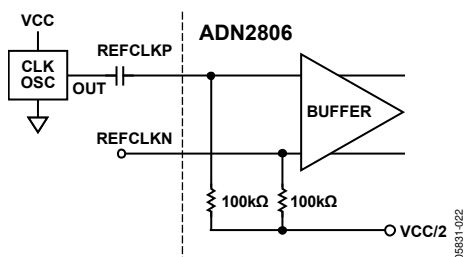

Figure 17. Single-Ended REFCLK Configuration

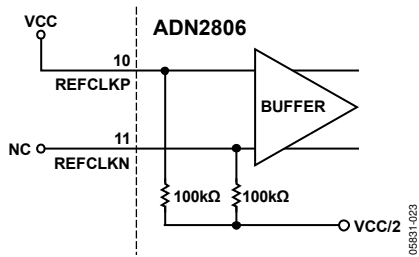

Figure 18. No REFCLK Configuration

There are two mutually exclusive uses, or modes, of the reference clock. The reference clock can be used either to help the ADN2806 lock onto data or to measure the frequency of the incoming data to within 0.01%. The modes are mutually exclusive because in the first use the user knows exactly what the data rate is and wants to force the part to lock onto only that data rate, and in the second use the user does not know what the data rate is and wants to measure it.

Lock-to-reference mode is enabled by writing a 1 to I<sup>2</sup>C Register Bit CTRLA[0]. Fine data rate readback mode is enabled by writing a 1 to I<sup>2</sup>C Register Bit CTRLA[1]. Writing a 1 to both of these bits at the same time causes an indeterminate state and is not supported.

### Using the Reference Clock to Lock onto Data

In this mode, the ADN2806 locks onto a frequency derived from the reference clock according to

$$\text{Data Rate}/2^{\text{CTRLA}[5:2]} = \text{REFCLK}/2^{\text{CTRLA}[7, 6]}$$

The user must provide a reference clock that is a function of the data rate. By default, the ADN2806 expects a reference clock of 19.44 MHz. Other options are 38.88 MHz, 77.76 MHz, and 155.52 MHz, which are selected by programming CTRLA[7, 6]. CTRLA[5:2] should be programmed to [0101] for all cases.

Table 11. CTRLA Settings

CTRLA[7, 6]	Range (MHz)	CTRLA[5:2]	Ratio
00	19.44	0101	2 <sup>5</sup>
01	38.88	0101	2 <sup>5</sup>
10	77.76	0101	2 <sup>5</sup>
11	155.52	0101	2 <sup>5</sup>

For example, if the reference clock frequency is 38.88 MHz and the input data rate is 622.08 Mbps, CTRLA[7, 6] is set to [01] to produce a divided-down reference clock of 19.44 MHz, and CTRLA[5:2] is set to [0101], that is, 5, because

$$622.08 \text{ Mbps}/19.44 \text{ MHz} = 2^5$$

In this mode, if the ADN2806 loses lock for any reason, it relocks onto the reference clock and continues to output a stable clock.

While the ADN2806 is operating in lock-to-reference mode, a 0 to 1 transition should be written into the CTRLA[0] bit to initiate a lock-to-reference clock command.

# ADN2806

## Using the Reference Clock to Measure Data Frequency

The user can also provide a reference clock to measure the recovered data frequency. In this case, the user provides a reference clock, and the ADN2806 compares the frequency of the incoming data to the incoming reference clock and returns a ratio of the two frequencies to within 0.01% (100 ppm) accuracy. The accuracy error of the reference clock is added to the accuracy of the ADN2806 data rate measurement. For example, if a 100 ppm accuracy reference clock is used, the total accuracy of the measurement is within 200 ppm.

The reference clock can range from 10 MHz to 160 MHz. By default, the ADN2806 expects a reference clock between 10 MHz and 20 MHz. If the reference clock is between 20 MHz and 40 MHz, 40 MHz and 80 MHz, or 80 MHz and 160 MHz, the user must configure the ADN2806 for the correct reference frequency range by setting two bits of the CTRLA register, CTRLA[7, 6]. Using the reference clock to determine the frequency of the incoming data does not affect the manner in which the part locks onto data. In this mode, the reference clock is used only to determine the frequency of the data.

Prior to reading back the data rate using the reference clock, the CTRLA[7, 6] bits must be set to the appropriate frequency range with respect to the reference clock being used. A fine data rate readback is then executed as follows:

1. Write a 1 to CTRLA[1]. This enables the fine data rate measurement capability of the ADN2806. This bit is level sensitive and can perform subsequent frequency measurements without being reset.
2. Reset MISC[2] by writing a 1 followed by a 0 to CTRLB[3]. This initiates a new data rate measurement.

3. Read back MISC[2]. If it is 0, the measurement is not complete. If it is 1, the measurement is complete and the data rate can be read back on FREQ[22:0]. The time for a data rate measurement is typically 80 ms.
4. Read back the data rate from FREQ2[6:0], FREQ1[7:0], and FREQ0[7:0].

The data rate can be determined by

$$f_{\text{DATARATE}} = (\text{FREQ}[22:0] \times f_{\text{REFCLK}}) / 2^{(14 + \text{SEL\_RATE})}$$

where:

FREQ[22:0] is the reading from FREQ2[6:0] (MSB byte, FREQ1[7:0], and FREQ0[7:0] (LSB byte).

$f_{\text{DATARATE}}$  is the data rate (Mbps).

$f_{\text{REFCLK}}$  is the REFCLK frequency (MHz).

SEL\_RATE is the setting from CTRLA[7, 6].

For example, if the reference clock frequency is 32 MHz, SEL\_RATE = 1, because the reference frequency falls into the 20 MHz to 40 MHz range, setting CTRLA[7, 6] to [01]. Assume for this example that the input data rate is 622.08 Mb/s (OC12). After following Step 1 through Step 4, the value that is read back on FREQ[22:0] = 0x9B851, which is equal to  $637 \times 10^3$ . Plugging this value into the equation yields

$$637e3 \times 32e6 / 2^{(14 + 1)} = 622.08 \text{ Mbps}$$

If subsequent frequency measurements are required, CTRLA[1] should remain set to 1. It does not need to be reset. The measurement process is reset by writing a 1 followed by a 0 to CTRLB[3]. This initiates a new data rate measurement. Follow Step 2 through Step 4 to read back the new data rate.

Note that a data rate readback is valid only if LOL is low. If LOL is high, the data rate readback is invalid.

Table 12.

D22	D21 ... D17	D16	D15	D14 ... D9	D8	D7	D6 ... D1	D0
FREQ2[6:0]			FREQ1[7:0]			FREQ0[7:0]		

# APPLICATIONS INFORMATION

## PCB DESIGN GUIDELINES

Proper RF PCB design techniques must be used for optimal performance.

### Power Supply Connections and Ground Planes

Use of one low impedance ground plane is recommended. The VEE pins should be soldered directly to the ground plane to reduce series inductance. If the ground plane is an internal plane and connections to the ground plane are made through vias, multiple vias can be used in parallel to reduce the series inductance, especially on Pin 23, which is the ground return for the output buffers. The exposed pad should be connected to the GND plane using plugged vias so that solder does not leak through the vias during reflow.

Use of a 22 μF electrolytic capacitor between VCC and VEE is recommended at the location where the 3.3 V supply enters the PCB. When using 0.1 μF and 1 nF ceramic chip capacitors, they should be placed between ADN2806 supply pins VCC and VEE, as close as possible to the ADN2806 VCC pins.

If connections to the supply and ground are made through vias, the use of multiple vias in parallel helps to reduce series inductance, especially on Pin 24, which supplies power to the high speed CLKOUTP/CLKOUTN and DATAOUTP/DATAOUTN output buffers. Refer to Figure 19 for the recommended connections.

By placing the power supply and GND planes adjacent to each other and using close spacing between the planes, excellent high frequency decoupling can be realized. The capacitance is given by

$$C_{PLANE} = 0.88\epsilon_r A/d \text{ (pF)}$$

where:

$\epsilon_r$  is the dielectric constant of the PCB material.

A is the area of the overlap of power and GND planes (cm<sup>2</sup>).

d is the separation between planes (mm).

For FR-4,  $\epsilon_r = 4.4$  and  $d = 0.25$  mm; therefore,

$$C_{PLANE} \sim 15 \text{ pF/cm}^2.$$

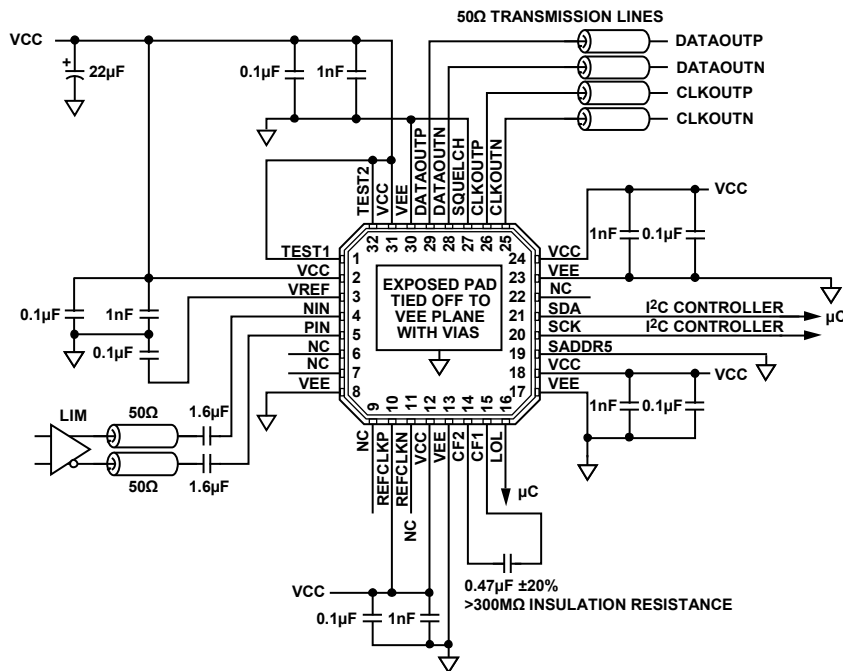

Figure 19. Typical ADN2806 Applications Circuit

05831-081

# ADN2806

## Transmission Lines

Minimizing reflections in the ADN2806 requires use of 50 Ω transmission lines for all pins with high frequency input and output signals, including PIN, NIN, CLKOUTP, CLKOUTN, DATAOUTP, and DATAOUTN (also REFCLKP and REFCLKN, if a high frequency reference clock is used, such as 155 MHz). It is also necessary for the PIN/NIN input traces to be matched in length and for the CLKOUTP/CLKOUTN and DATAOUTP/DATAOUTN output traces to be matched in length to avoid skew between the differential traces.

The high speed inputs, PIN and NIN, are internally terminated with 50 Ω to an internal reference voltage (see Figure 20). A 0.1 μF is recommended between VREF, Pin 3, and GND to provide an ac ground for the inputs.

As with any high speed, mixed-signal design, take care to keep all high speed digital traces away from sensitive analog nodes.

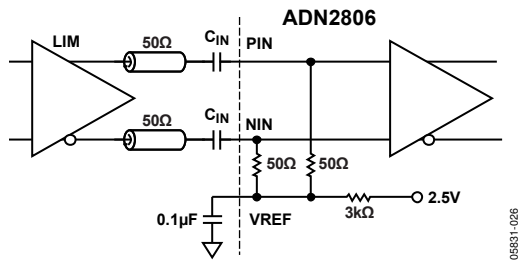

Figure 20. ADN2806 AC-Coupled Input Configuration

## Soldering Guidelines for Lead Frame Chip Scale Package

The lands on the 32-lead LFCSP are rectangular. The printed circuit board (PCB) pad for these should be 0.1 mm longer than the package land length and 0.05 mm wider than the package land width. The land should be centered on the pad. This ensures that the solder joint size is maximized. The bottom of the chip scale package has a central exposed pad. The pad on the PCB should be at least as large as this exposed pad. The user must connect the exposed pad to VEE using plugged vias so that solder does not leak through the vias during reflow. This ensures a solid connection from the exposed pad to VEE.

## Choosing AC Coupling Capacitors

AC coupling capacitors at the input (PIN, NIN) and output (DATAOUTP, DATAOUTN) of the ADN2806 can be optimized for the application. When choosing the capacitors, the time constant formed with the two 50 Ω resistors in the signal path must be considered. When a large number of consecutive identical digits (CIDs) are applied, the capacitor voltage can droop due to baseline wander (see Figure 21), causing pattern-dependent jitter (PDJ).

The user must determine how much droop is tolerable and choose an ac coupling capacitor based on that amount of droop. The amount of PDJ can then be approximated based on the capacitor selection. The actual capacitor value selection can require some trade-offs between droop and PDJ.

For example, assuming that 2% droop can be tolerated, the maximum differential droop is 4%. Normalizing to V<sub>p-p</sub>:

$$\text{Droop} = \Delta V = 0.04 V = 0.5 V_{p-p} (1 - e^{-t/\tau}); \text{ therefore, } \tau = 12t$$

where:

$\tau$  is the RC time constant (C is the ac coupling capacitor, R = 100 Ω seen by C).

$t$  is the total discharge time, which is equal to  $nT$ , where  $n$  is the number of CIDs, and  $T$  is the bit period.

The capacitor value can then be calculated by combining the equations for  $\tau$  and  $t$ :

$$C = 12 nT/R$$

Once the capacitor value is selected, the PDJ can be approximated as

$$PDJ_{p\text{-}p} = 0.5 t_r (1 - e^{(-nT/RC)})/0.6$$

where:

$PDJ_{p\text{-}p}$  is the amount of pattern-dependent jitter allowed (<0.01 UI p-p typical).

$t_r$  is the rise time, which is equal to  $0.22/BW$ , where  $BW \sim 0.7$  (bit rate).

Note that this expression for  $t_r$  is accurate only for the inputs. The output rise time for the ADN2806 is  $\sim 100$  ps regardless of the data rate.

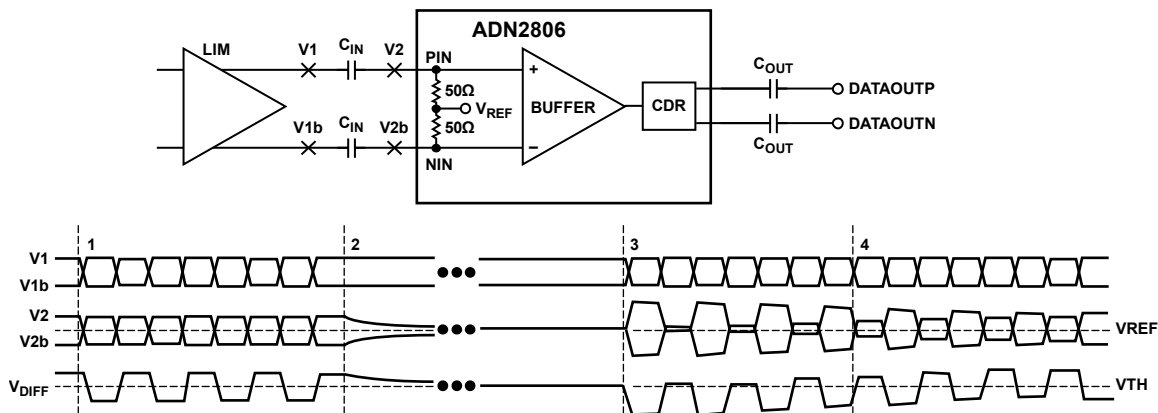

$V_{DIFF} = V_2 - V_{2b}$   
 $V_{TH} = \text{ADN2806 THRESHOLD}$

**NOTES:**

1. DURING DATA PATTERNS WITH HIGH TRANSITION DENSITY, DIFFERENTIAL DC VOLTAGE AT V1 AND V2 IS ZERO.
2. WHEN THE OUTPUT OF THE TIA GOES TO CID, V1 AND V1b ARE DRIVEN TO DIFFERENT DC LEVELS. V2 AND V2b DISCHARGE TO THE VREF LEVEL, WHICH EFFECTIVELY INTRODUCES A DIFFERENTIAL DC OFFSET ACROSS THE AC COUPLING CAPACITORS.
3. WHEN THE BURST OF DATA STARTS AGAIN, THE DIFFERENTIAL DC OFFSET ACROSS THE AC COUPLING CAPACITORS IS APPLIED TO THE INPUT LEVELS CAUSING A DC SHIFT IN THE DIFFERENTIAL INPUT. THIS SHIFT IS LARGE ENOUGH SUCH THAT ONE OF THE STATES, EITHER HIGH OR LOW DEPENDING ON THE LEVELS OF V1 AND V1b WHEN THE TIA WENT TO CID, IS CANCELED OUT. THE QUANTIZER DOES NOT RECOGNIZE THIS AS A VALID STATE.
4. THE DC OFFSET SLOWLY DISCHARGES UNTIL THE DIFFERENTIAL INPUT VOLTAGE EXCEEDS THE SENSITIVITY OF THE ADN2806. THE QUANTIZER CAN RECOGNIZE BOTH HIGH AND LOW STATES AT THIS POINT.

Figure 21. Example of Baseline Wander

05831-027

## OUTLINE DIMENSIONS

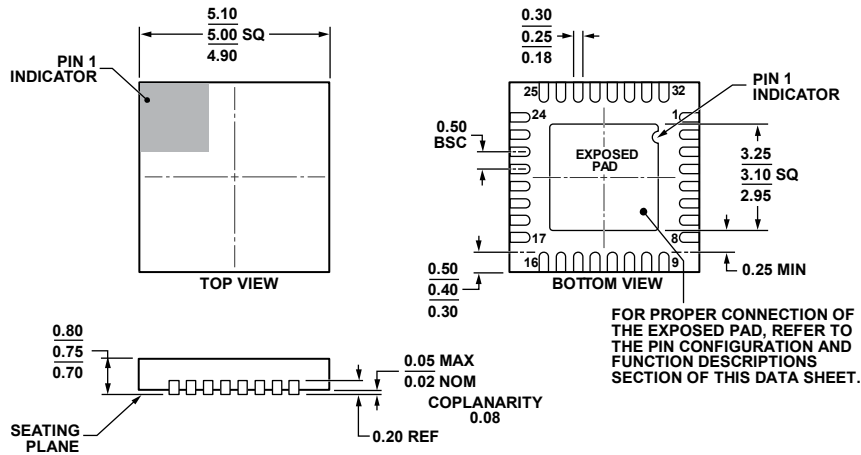

COMPLIANT TO JEDEC STANDARDS MO-220-WHHD.

Figure 22. 32-Lead Lead Frame Chip Scale Package [LFCSP\_VQ]  
5 mm x 5 mm Body, Very Thin Quad  
(CP-32-7)  
Dimensions shown in millimeters

112408-A

## ORDERING GUIDE

Model <sup>1</sup>	Temperature Range	Package Description	Package Option
ADN2806ACPZ	-40°C to +85°C	32-Lead LFCSP_VQ	CP-32-7
ADN2806ACPZ-500RL7	-40°C to +85°C	32-Lead LFCSP_VQ, Tape-Reel, 500 Pieces	CP-32-7
ADN2806ACPZ-RL7	-40°C to +85°C	32-Lead LFCSP_VQ, Tape-Reel, 1500 Pieces	CP-32-7
EVAL-ADN2806EBZ		Evaluation Board	

<sup>1</sup> Z = RoHS Compliant Part.

I<sup>2</sup>C refers to a communications protocol originally developed by Philips Semiconductors (now NXP Semiconductors).