



Chipsmall Limited consists of a professional team with an average of over 10 year of expertise in the distribution of electronic components. Based in Hongkong, we have already established firm and mutual-benefit business relationships with customers from,Europe,America and south Asia,supplying obsolete and hard-to-find components to meet their specific needs.

With the principle of “Quality Parts,Customers Priority,Honest Operation,and Considerate Service”,our business mainly focus on the distribution of electronic components. Line cards we deal with include Microchip,ALPS,ROHM,Xilinx,Pulse,ON,Everlight and Freescale. Main products comprise IC,Modules,Potentiometer,IC Socket,Relay,Connector.Our parts cover such applications as commercial,industrial, and automotives areas.

We are looking forward to setting up business relationship with you and hope to provide you with the best service and solution. Let us make a better world for our industry!



## Contact us

Tel: +86-755-8981 8866 Fax: +86-755-8427 6832

Email & Skype: info@chipsmall.com Web: www.chipsmall.com

Address: A1208, Overseas Decoration Building, #122 Zhenhua RD., Futian, Shenzhen, China



## Design Guide



Lead (Pb) Free  
RoHS 6 fully  
compliant



### Introduction

This design guide describes the design of a low power consumption optical mouse using the Texas Instrument MSP430F1222 microcontroller, the Avago ADNS-3040 optical sensor and a 27 MHz FSK transmitter implemented with discrete components. The receiver is implemented with a TI TRF9700 receiver and Cypress CY7C63743 USB controller. The document discusses the reference design hardware and the firmware implementation. Included in Appendix A is the schematic for this reference design mouse. The software section of this document describes the architecture of the firmware required to implement the mouse functions. The MSP430F1222 data sheet is available on the TI web site at [www.ti.com](http://www.ti.com). The ADNS-3040 data sheet is available from the Avago web site at [www.avagotech.com](http://www.avagotech.com). USB controller data sheet can be found on the Cypress web site: [www.cypress.com](http://www.cypress.com)

### Key reference design objectives:

1. Highlight the low-power benefit of the ADNS-3040
2. Demonstrate multiple RF technologies: 27 MHz and 2.4 GHz
3. Feature a Flash-based development environment to facilitate rapid firmware changes

### Reference Design Overview

The image-based optical mouse sensor takes snap shots of the surface it is navigating on. It measures changes in position by comparing the sequential images (frames) and mathematically determines the direction and magnitude of movement. The traditional dual-channel optical encoder generates the quadrature Z-wheel movement signals. This design guide illustrates the hardware connection of a LED-based optical mouse with standard configuration; as well as the firmware management and the handling of the USB protocols. USB protocol provides a standard way of reporting mouse movement and button presses to the PC. The Windows HID driver interprets the USB data and performs the cursor movements and mouse clicks.

The functional block diagram of the reference design mouse is shown in Figure 1. The optical sensor detects the X and Y movements. An optical quadrature encoder provides the Z-wheel movement. Each of the button switches is pulled up normally and provides a Ground when pressed. The MAX1722 boost regulator maintains the 2.7V operating voltage for the reference design mouse from two regular AA Alkaline batteries in parallel.

*This preliminary data is provided to assist you in the evaluation of product(s) currently under development. Until Avago Technologies releases this product for general sales, Avago Technologies reserves the right to alter prices, specifications, features, capabilities, functions, release dates, and remove availability of the product(s) at anytime.*

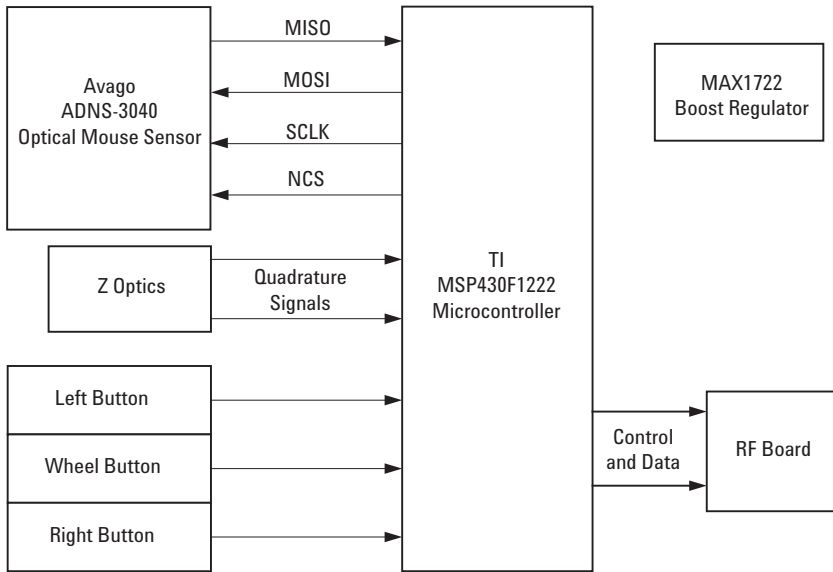

Figure 1. ADNK-3034-TI27 Reference Design Mouse functional Block Diagram

**Theory of Operation**

**Navigation Technology**

The heart of the ADNS-3040 navigation sensor is a CMOS image array. An LED and an optical system illuminate the surface that the ADNS-3040 is navigating on. The texture of the surface casts bright and dark spots forming distinct images as the sensor is moved across the surface. A Digital Signal Processing (DSP) engine and its built-in algorithm evaluate these images and determine the magnitude and direction of the movement.

The motion data is made available in the delta\_X and delta\_Y registers for the system controller to retrieve. An extensive power saving topology is implemented within the ADNS-3040 navigation engine. A Motion pin (output) is available to act as the system interrupt. As long as there is no motion the system can remain in Sleep mode allowing maximum battery power saving. Based on the last detected motion the ADNS-3040 navigation engine enters various power saving modes when no new motion occurs. These power saving features make the ADNS-3040 ideally for wireless applications.

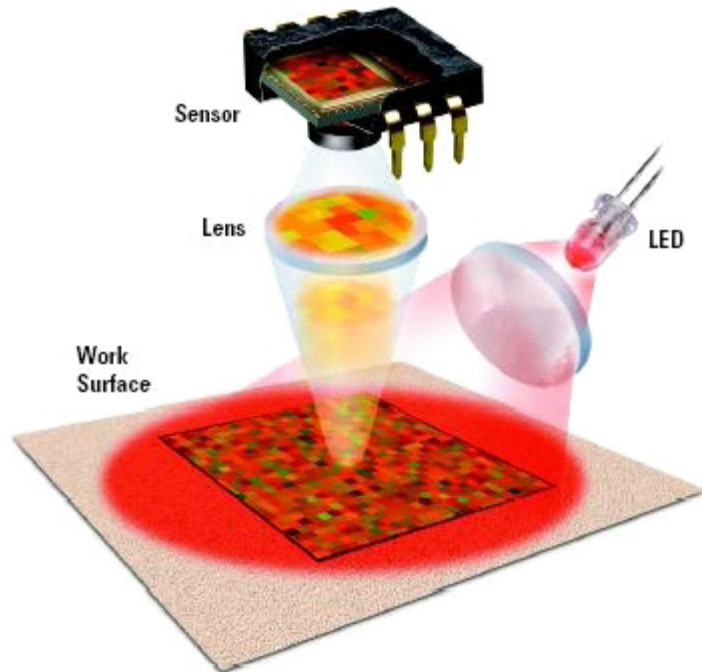
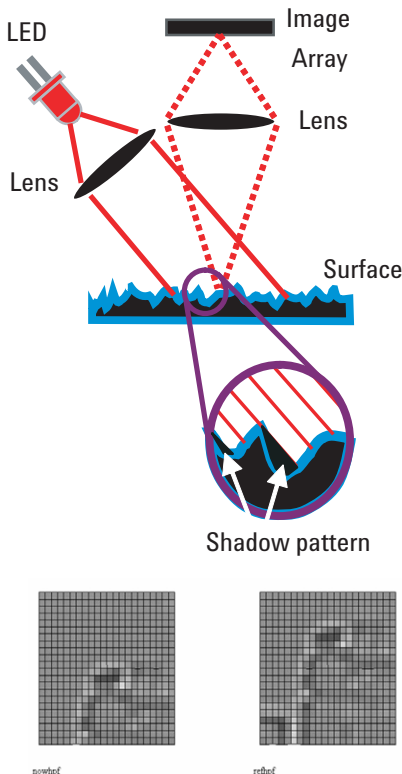

Figure 2. Illustration of Optical Navigation technology

## Z Wheel

The motion of Z-wheel is detected using the quadrature signal generated by optical sensors. Two phototransistors are connected in a source-follower configuration forming Channel A and Channel B. An infrared LED shines, causing the phototransistors to turn on. In between the phototransistors and the LED is a pinwheel that rotates. The spokes of this pinwheel is mechanically designed to interrupt the infrared light such that the phototransistors are turned on and off in a quadrature output pattern. Every change in the phototransistor outputs represents a count of Z-wheel movement. Comparing the last state of the optics to the current state derives directional information. As shown in Figure 3 below, rotating the wheel forward produces a unique set of state transitions, and rotating the wheel backward produces another set of unique state transitions.

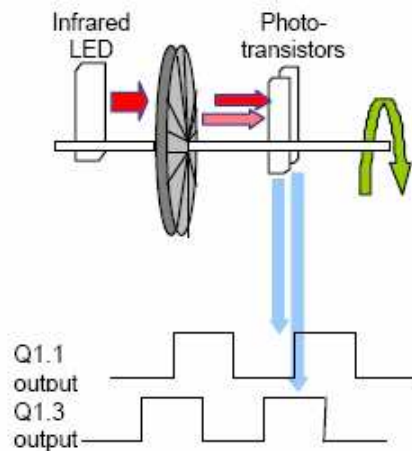

Figure 3. Optics Quadrature Signal Generation

## Mouse Buttons

Mouse buttons are connected as standard switches. These switches are pulled up by the pull up resistors inside the microcontroller. When the user presses a button, the switch will be closed and the pin will be pulled LOW to GND. A LOW state at the pin is interpreted as the button being pressed. A HIGH state is interpreted as the button has been released or the button is not being pressed. Normally the switches are debounced in firmware for 15-20ms. In this reference design there are three switches: left, Z-wheel, and right.

## Hardware Implementation

### Optical Mouse Sensor

This reference design features the ADNS-3040 optical navigation engine. It contains an Image Acquisition System (IAS), a Digital Signal Processor (DSP), and a four-wire Serial Peripheral Interface consists of the serial clock (SCLK), the master-in/slave-out (MISO) and the master-out/slave-in (MOSI). In addition a fourth signal chip select (NCS) is used to select the device on the SPI buss. Motion, is an additional output from the ADNS-3040 intended to act as an interrupt to the microcontroller whenever the ADNS-3040 senses motion. When the mouse is moved the ADNS-3040 alerts the system controller by activating the Motion signal triggering an interrupt service routine. At the same time the ADNS-3040 accumulates the horizontal and vertical displacements (count per inch, or cpi) in its Delta\_X and Delta\_Y registers respectively. The ADNS-3040 deactivates the Motion signal as soon as movement stops. The Smart-Speed technology automatically optimizes the frame rate by examining the acquired images of the surface. It also manages the integrated LED driver to coordinate with the shutter.

The system controller reads the motion information and reports it to the PC to update the cursor position.

The advantages of using ADNS-3040 optical sensor are the efficient power management, high tracking accuracy, and simple communications with the microcontroller via the full duplex SPI port.

To learn more about sensor's technical information, please visit the Avago web site at <http://www.avagotech.com>

## Microcontroller

The Texas Instruments MSP430 family of ultra-low power microcontrollers consists of several devices featuring different sets of peripherals targeted for various applications. The architecture, combined with five low-power modes, is optimized to achieve extended battery life in portable measurement applications. The device features a powerful 16-bit RISC CPU, 16-bit registers, and constant generators that attribute to maximum code efficiency. The Digitally Controlled Oscillator (DCO) allows wake-up from low-power modes to active mode in less than 6  $\mu$ sec.

The specific device used in this reference design is the MSP430F1222 with 28 pin to accommodate ample amount of I/O. It is an ultra-low power mixed-signal microcontrollers with a built-in 16-bit timer, 10-bit A/D converter with integrated reference and Data Transfer Controller (DTC), and 14 (20 pin package) or 22 (28 pin package) general purpose I/O pins. The MSP430x12x2 series microcontrollers have built-in communication capability using asynchronous (UART) and synchronous (SPI) protocols.

### Serial Peripheral Interface (SPI)

The MSP430F1222 provides a dedicated hardware-based Serial Peripheral Interface (SPI). The three-wire interface supports byte serial communication in either Master or Slave mode. In this reference design the MSP430F1222 always acts as the master and initiates all SPI communications with external SPI device(s), in this case the ADNS-3040.

### Z Wheel Quadrature Encoder

A standard two-channel, incremental optical quadrature encoder and an IR LED provide the scroll wheel function. The MSP430F1222 manages the IR LED directly. Since achieving low-power consumption is one of the main objectives, the Z-wheel LED is only enabled when the MSP430 needs to read the output states of the optical quadrature encoder to the MSP430 port pins while in ACTIVE mode. The Z-wheel LED is pulsed on for approximately 40  $\mu$ sec every 2 msec while in ACTIVE mode to read the current position of the scroll wheel, thus saving power since the

Z-wheel LED is only on for a duty cycle of 2%. The outputs of the two-channel quadrature encoder are squarewaves that are 90° out of phase. The phase relationship of these signals encodes the directions of scroll wheel rotations. Within the MSP430, an internal Quadrature Encoder Pulse (QEP) state machine interprets these signals and increments or decrements a counter based on the direction and movement of the scroll wheel.

### Wireless RF Technology

In order to provide the maximum flexibility the reference design mouse utilizes two circuit boards. The main board consists of the ADNS-3040 navigation sensor/LED, the MSP430F1222 microcontroller, the scroll wheel LED/encoder and the button switches. A 10-pin header connects the RF daughter card to the main board. The 27 MHz FSK transmitter circuit is based on a previously published reference design.

### Some details on ADNK-3043-T127

The ADNK-3043-T127 reference design kit allows users to evaluate the performance of the Optical Tracking Engine (sensor, lens, LED assembly clip, LED) over a 27 MHz RF connection. This kit also enables users to understand the recommended mechanical assembly. (See Appendix C, D and E)

### System Requirements

PCs using Windows® 95/ Windows® 98/ Windows® NT/ Windows® 2000 with standard 3-button USB mouse driver loaded.

### Functionality

27 MHz wireless USB, 3-button, scroll wheel, 800 cpi

### USB Operating Mode

The receiver dongle is hot pluggable into the USB port. The PC does not need to be powered off when plugging or unplugging the receiver dongle for the evaluation mouse.

### To Disassemble the ADNK-3043 TI27 Unit

The ADNK-3034 TI27 comprises of the plastic mouse casing, a main printed circuit board (PCB), lens, buttons, and a 27 MHz RF daughter card, and a 27 MHz USB receiver dongle. (See Figure 4.) Removing the screws located at the base of the unit separate the top and the bottom of the mouse casing. Removing the PCB assembly from the base plate further disassembles the mouse unit. Be careful with the battery terminals while separating the PCB assembly with the bottom casing.

**CAUTION: THE LENS IS NOT PERMANENTLY ATTACHED TO THE SENSOR AND WILL DROP OUT OF THE ASSEMBLY.**

While reassembling the components, please make sure that the Z height (Distance from lens reference plane to surface) is maintain. Refer to Figure 5.

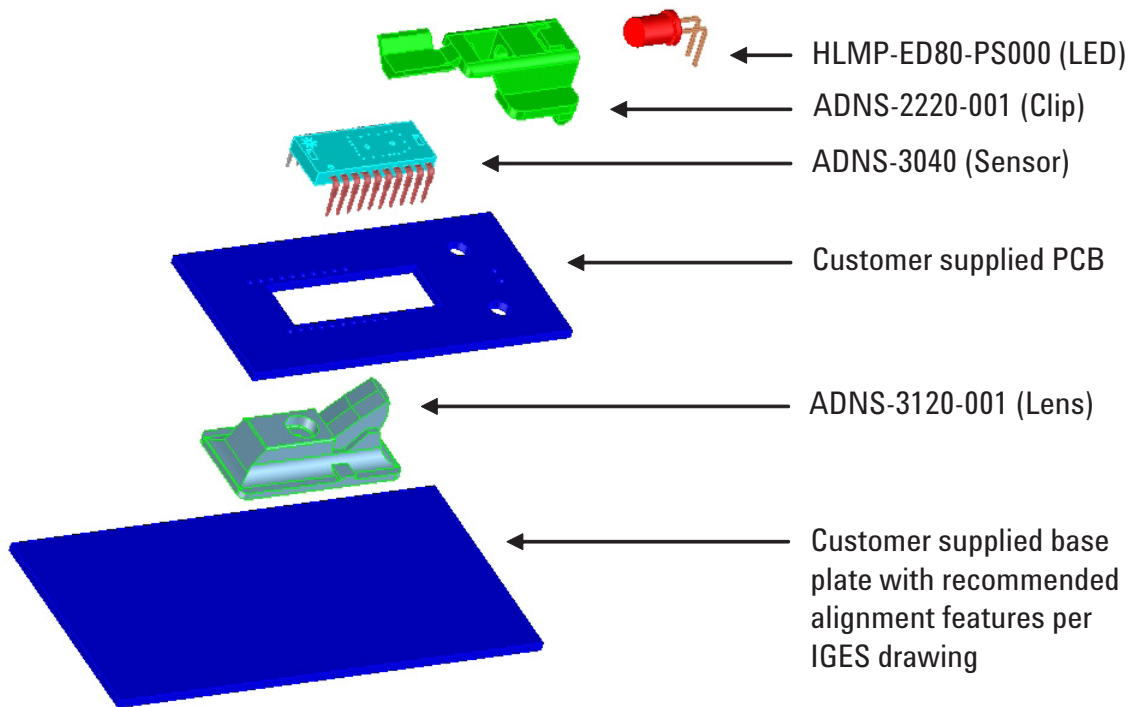

Figure 4. Exploded view of the ADNS-3040 optical tracking engine

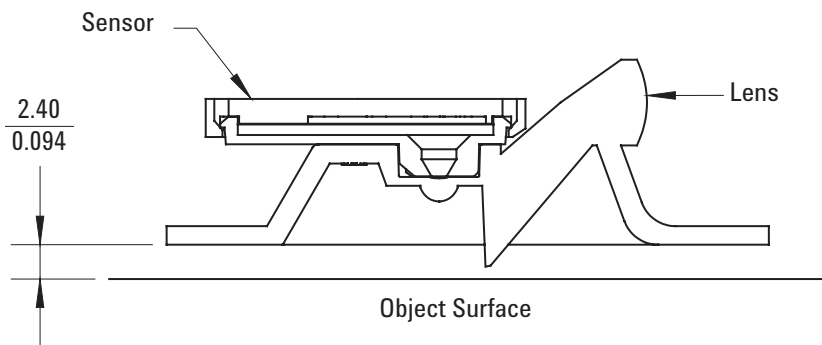

Figure 5. Distance from lens reference plane to surface

## Regulatory Requirements

- Passes FCC B and worldwide analogous emission limits when assembled into a mouse with unshielded cable and following Avago recommendations.
- Passes EN61000-4-4/IEC801-4 EFT tests when assembled into a mouse with unshielded cable and following Avago recommendations.
- UL flammability level UL94 V-0.
- Provides sufficient ESD creepage/clearance distance to avoid discharge up to 15kV when assembled into a mouse according to usage instructions above.
- For eye safety consideration, please refer to the document, Eye Safety Calculation AN1228 available on the web site, <http://www.avagotech.com/view/opticalnavigation>.

Below is the summary of the components contained in the ADNK-3034-TI27 Designer's Kit.

### Sensor

The sensor technical information is contained in the ADNS-3040 Data Sheet.

### Other system components

Technical information on the TI MSP430F1222 microcontroller is contained in the TI Data Sheet. Please contact your local TI office for theMSP430 development tools. These tools will allow the designer to make changes and recompile the source code; perform In-Circuit Emulation and debug new code for added features.

Programming support and programmer adaptors for the MSP430 can be found through TI or through other 3<sup>rd</sup> party programming tool companies. For further information on this product, please contact Texas Instrument.

Cypress Semiconductor provides extensive development tools for the xxxxx USB controller used in the receiver dongle.

### Lens

The lens technical information is contained in the ADNS-3120-001 Data Sheet. The flange on the standard ADNS-3120-001 lens is for ESD protection.

### LED Assembly Clip

The information on the assembly clip is contained in the ADNS-2220-001 Data Sheet.

### LED

The LED technical information is contained in the HLMP-ED80-XX000 Data Sheet and Application Note AN-1228. Additional application notes regarding Eye Safety Requirements are also available at Avago's website.

### Base Plate Feature – IGES File

The IGES file on the CD-ROM provides recommended base plate molding features to ensure optical alignment. This includes a typical PCB assembly diagrams recommended solder fixture in assembly and exploded view, as well as solder plate. See Appendix C for details.

### Reference Design Documentation – Gerber File

The Gerber File presents detailed schematics used in ADNK-3043-TI27 in PCB layout form. The file for this reference design can be found in the Hardware Support files folder in the CD-Rom.

### Overall circuit

A schematic of the overall circuit is shown in Appendix A of this document. Appendix B lists the bill of materials.

## Firmware Implementation

The firmware for this reference design is written in the C language. The following files are required to compile the mouse firmware.

File	Description
MSP430_AVAGO_ADNS-3040.c	main mouse firmware
CRC-8.c	Routines for CRC-8 generation
wm430_buttons.c	used to store button state data for tx message
wm430_system.c	
wm430_transmitter.c	Implements the RF transmitter protocol
wm430_wheel.c	Implements the logic to detect scroll wheel movement FSKDATAPLUSENCODING - used to enable MSP430 to shift data out via FSK scheme by toggling the RF_DATA line at specific bit periods

The user should insert the receiver dongle into an available USB port at the computer. Install two AA alkaline batteries into the battery compartment. Pay special attention to the polarities of the two batteries. The reference design mouse is designed to work with two AA batteries in parallel or just one AA battery. Press the connect button on the receiver dongle and while the LEDs are flashing press the connect button at the underside of the mouse. When the mouse is properly connected to the dongle, every time it receives a transmission from the mouse the LED lights up.



# Appendix A: Schematic Diagram of the Main Board

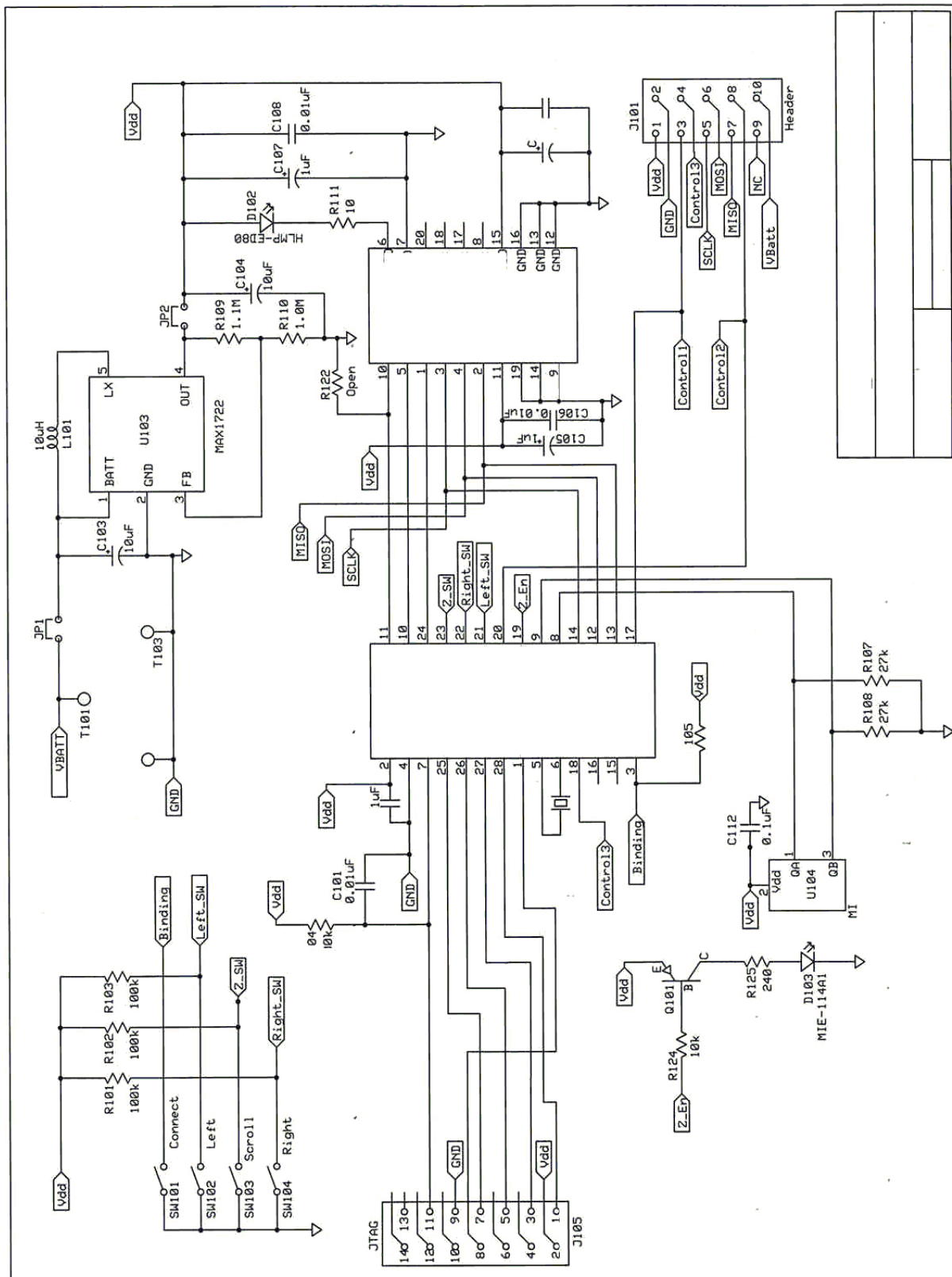

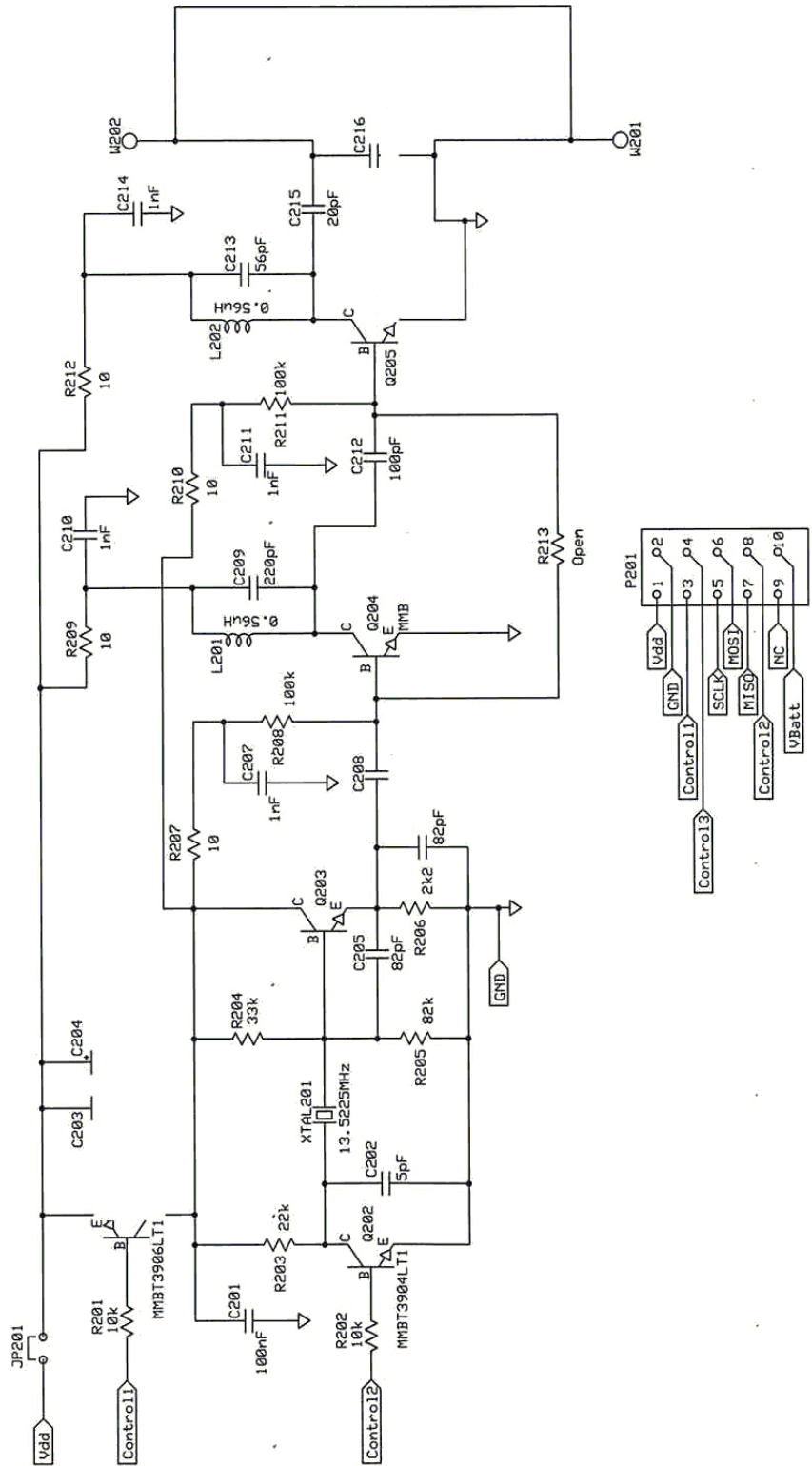

Figure A1. Schematic diagram of the RF Transmitter Board

## Appendix B: Bill of Materials for Components Shown on schematic (Main Board and RF Board)

Part Type	Qty	Value	Designators
Optical Sensor Device	1		U101
Optical Sensor LED	1		D102
Optical Sensor Lens	1		Not shown on schematic
Optical Sensor Clip	1		Not shown on schematic
Microcontroller	1		U102
DC/DC Converter	1		U103
Z LED	1		D103
Z Encoder	1	3 PIN	U104
Resistor (0805)	5	100 k	R101, R102, R103, R104, R105
Resistor (0805)	1	3.3M	R124
Resistor (0805)	1	240	R125
Resistor (0805)	2	27K	R107, R108
Resistor (0805)	1	1.1 M	R109
Resistor (0805)	1	1.0 M	R110
Resistor (0805)	1	10	R111
Resistor (0805)	1	0	R106
Resistor (0805)	1	No Load	R122
Ceremic capacitor (0603)	4	.01UF 50V	C101, C106, C108, C110
Ceremic capacitor (0603)	2	.1UF 25V	C102, C112
Tantalum capacitor	3	1 uF 50V	C105, C107, C109
Tantalum capacitor	2	10uF 25V	C103, C104
NPNT RANSISTOR	1	MMBT3906LT1	Q101
Switch	3	SPDT	SW101, SW102, SW103
Switch, light touch	1	6mmx6mmx4.3mm	SW104
Inductor	1	10 uH	L101
Crystal	1	32.768 kHz	XTAL101
Header, pins 2mm	2	2x5	J101
Header, socket, 2mm	2	2 x 7	J105
Battery Spring, common	1	2X7	T101
Battery spring +	1		T102
Battery spring -	1		T103

<b>Description</b>	<b>Qty</b>	<b>Value</b>	<b>Reference</b>
Resistor (0603)	2	10k	R201, R202
Resistor (0603)	1	22k	R203
Resistor (0603)	1	33k	R204
Resistor (0603)	1	82k	R205
Resistor (0603)	1	2k2	R206
Resistor (0603)	4	10	R207, R209, R210, R212
Resistor (0603)	2	100k	R208, R211
Resistor (0603)	1	Open	R213
Ceremic Capacitor (0603)	2	0.1uF	C201, C203
Ceremic Capacitor (0603)	2	100pF	C208, C212
Ceremic Capacitor (0603)	2	82pF	C205, C206
Ceremic Capacitor (0603)	1	5pF	C202
Ceremic Capacitor (0603)	1	150pF	C216
Ceremic Capacitor (0603)	4	0.001uF (1000pF)	C207, C210, C211, C214
Ceremic Capacitor (0603)	1	20pF	C215
Ceremic Capacitor (0603)	1	220pF	C209
Ceremic Capacitor (0603)	1	56pF	C213
	1	10uF	C204
Inductor	2	0.56uH "0.5 AXIAL"	L201, L202
NPN Transistor	4	MMBT3904LT1	Q202, Q203, Q204, Q205
PNP Transistor	1	MMBT3906LT1	Q201
4-PIN Header	2	1x4 pin, 2mm pitch (M)	J201, J202
1-PIN Through Hole	2	Hole for external wire antenna connection	W201, W202
Crystal	1	13.5225MHz (M1)	XTAL201

## Appendix C: Base Plate Feature

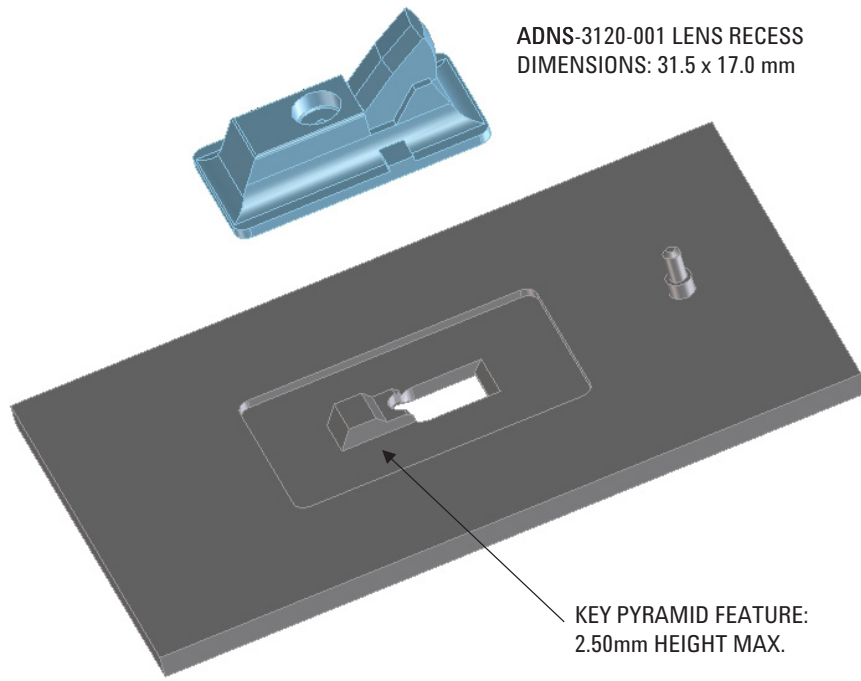
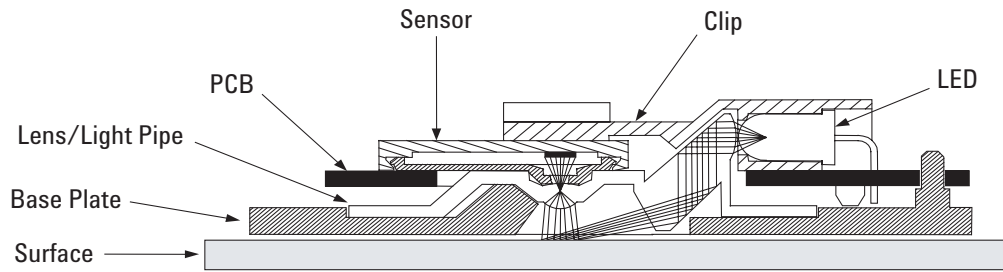

Figure C1: Illustration of base plate mounting features.

## Appendix D: Sectional view of PCB assembly



**Figure D1: Sectional view of PCB assembly highlighting all optical mouse components (optical mouse sensor, clip, lens, LED, PCB, and base plate).**

## Appendix E: Receiver dongle Implementation

Please refer to the following Cypress document:

Designing a Low Cost 27MHz Wireless Optical Mouse  
Using the Cypress CY7C63743 USB Microcontroller,  
Avago ADNS-3040 Optical Sensor and  
Texas Instruments MSP430 Microcontroller and  
TRF7900 27MHz Receiver

## Appendix F: Kit Components

The designer's kit contains components as follows:

Part Number	Description	Name	Quantity
ADNS-3040	Solid-State Optical Mouse Sensor	Sensor	5
ADNS-3120-001	Trim Lens Plate	Lens	5
ADNS-2220-001	LED Assembly Clip	LED Clip	5
HLMP-ED80-PS000		LED	5
ADNK-3043-TI27 CD	Includes Documentation and Support Files for ADNK-3043-TI27		1

### Documentation

- a. ADNS-3040 Ultra Low Power Optical Mouse Data Sheet
- b. ADNS-3120-001 Solid State Optical Mouse Lens Data Sheet
- c. ADNS-2220-001 LED Assembly Clip Data Sheet
- d. HLMP-ED80-XX000 LED Data Sheet
- e. Battery Life Calculation for An Ultra Low-Power Wireless Optical Mouse Application Note 5243
- f. Texas Instrument MSP430x11x12, MSP430x12x12 Mixed Signal Microcontroller Data Sheet
- g. Texas Instrument Fully Integrated Analog Front-End Dual Receiver Based Unit for 27MHz Wireless Mouse and Keyboard System Data Sheet
- h. Cypress CY7C63743 Microcontroller Data Sheet Data Sheet

### Hardware Support Files

- a. ADNK-3043-TI27 BOM List
- b. ADNK-3043-TI27 Schematic
- c. ADNK-3043-TI27 Gerber File
- d. IGES Base Plate Feature File

### Software Support Files

- a. Microcontroller Firmware

For product information and a complete list of distributors, please go to our web site: [www.avagotech.com](http://www.avagotech.com)

Avago, Avago Technologies, and the A logo are trademarks of Avago Technologies, Limited in the United States and other countries. Data subject to change. Copyright © 2006 Avago Technologies Limited. All rights reserved.  
AV02-0434EN - May 16, 2007

